



Europäisches Patentamt
European Patent Office
Office européen des brevets



(11) EP 0 929 122 A2

(12) EUROPEAN PATENT APPLICATION

(43) Date of publication:
14.07.1999 Bulletin 1999/28

(51) Int. Cl.⁶: H01Q 19/06

(21) Application number: 98121988.4

(22) Date of filing: 19.11.1998

(84) Designated Contracting States:
AT BE CH CY DE DK ES FI FR GB GR IE IT LI LU
MC NL PT SE
Designated Extension States:
AL LT LV MK RO SI

(30) Priority: 08.01.1998 US 4759
07.07.1998 US 110462
07.07.1998 US 110687

(71) Applicant: E*Star, Inc.
Los Gatos, CA 95030 (US)

(72) Inventors:
• Muhlhauser, Nicholas L.
Los Gatos, California 95030 (US)
• Cannizzaro, Kenneth P.
Los Gatos, California 95030 (US)
• Hewett, Brian C.
Los Altos, California 94022 (US)

(74) Representative:
Prato, Roberto et al
STUDIO TORTA S.r.l.,
Via Viotti 9
10121 Torino (IT)

(54) Reflector based dielectric lens antenna system

(57) A bifocal lens for use in a multiple beam antenna system including a reflector that is at least partially parabolic in one dimension and a pair of waveguides. Multiple received beams are received and reflected by the reflector into an orthogonal mode junction which separates signals of a first polarity from signals of a second orthogonal polarity. The signals of the first polarity are forwarded into a first waveguide and the orthogonal signals of the second polarity are forwarded into a second parallel waveguide. A plurality of satellites may be accessed simultaneously thus allowing the user to utilize both signals at the same time. The bifocal lenses may be located in the waveguides, respectively, with each lens including a step portion defined in at least one edge thereof for matching purposes.

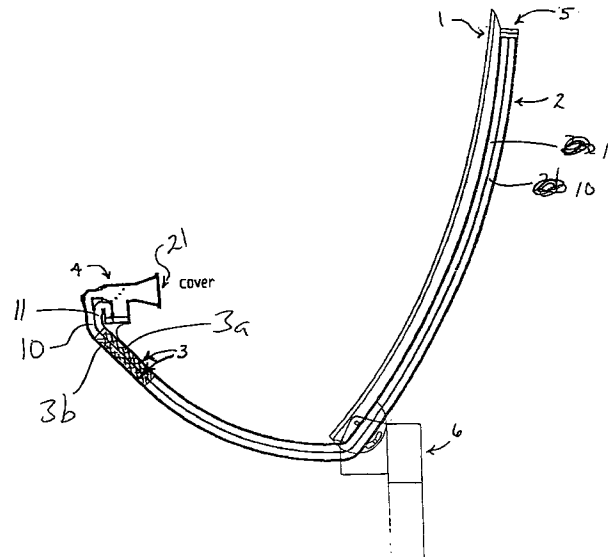

FIG. 1

EP 0 929 122 A2

Description

[0001] This invention relates to a multiple beam antenna system, including at least one bifocal lens. More particularly, this invention relates to a multiple beam antenna system including a reflective member used in combination with a pair of dielectric bifocal lenses.

BACKGROUND OF THE INVENTION

[0002] High gain antennas are widely useful for communication purposes such as radar, television receive-only (TVRO) earth station terminals, and other conventional sensing/transmitting uses. In general, high antenna gain is associated with high directivity, which in turn arises from a large radiating aperture.

[0003] U.S. Patent No. 4,845,507 discloses a modular radio frequency array antenna system including an array antenna and a pair of steering electromagnetic lenses. Unfortunately, the array antenna system of the '507 patent cannot simultaneously receive both right-hand and left-handed circularly polarized signals (i.e. orthogonal signals), and furthermore cannot simultaneously receive signals from different satellites wherein the signals are right-handed circularly polarized, left-handed circularly polarized, linearly polarized, or any combination thereof.

[0004] U.S. Patent No. 5,061,943 discloses a planar array antenna assembly for reception of linear signals. Unfortunately, the array of the '943 patent, while being able to receive signals in the fixed satellite service (FSS) and the broadcast satellite service (BSS) at 10.75 to 11.7 GHz and 12.5 to 12.75 GHz, respectively, cannot receive signals (without significant power loss and loss of polarization isolation) in the direct broadcast (DBS) band, as the DBS band is circular (as opposed to linear) in polarization.

[0005] U.S. Patent No. 4,680,591 discloses an array antenna including an array of helices adapted to receive signals of a single circular polarization (i.e. either right-handed or left-handed). Unfortunately, because satellites transmit in both right and left-handed circular polarizations to facilitate isolation between channels and provide efficient bandwidth utilization, the array antenna system of the '591 patent is blind to one of the right-handed or left-handed polarizations because all elements of the array are wound in a uniform manner (i.e. the same direction).

[0006] Conventional lens matching techniques do not lend themselves to use in commercial production of lens inclusive antenna systems in significant volume.

[0007] It is apparent from the above that there exists a need in the art for a multiple beam array antenna system (e.g. of the TVRO, DBS or BSS type) which is small in size, cost effective, and able to increase gain without significantly increasing cost. There also exists a need for such a multiple beam antenna system having the

ability to receive each of circularly polarized including right-handed circularly polarized signals, left-handed circularly polarized signals, and/or linearly polarized signals, horizontally polarized signals, vertically polarized signals, and also optionally any combination of or variation of linearly and/or circularly polarized signals. Additionally, the need exists for such an antenna system having the potential to simultaneously receive signals from different satellites, the different signals received being of the circularly polarized type or of the linearly polarized type, or combinations thereof.

[0008] There also exists a need in the art for an improved lens having satisfactory matching characteristics, which is applicable in commercial production of multibeam antenna systems in significant volume.

[0009] It is a purpose of this invention to fulfill the above-described needs in the art, as well as other needs apparent to the skilled artisan from the following detailed description of this invention.

SUMMARY OF THE INVENTION

[0010] It is an object of this invention provide an improved lens (e.g. bifocal lens) for use in multibeam antenna systems.

[0011] Generally speaking, this invention fulfills the above-described needs in the art by providing a multiple beam antenna system for simultaneously receiving/transmitting orthogonal signals of different polarity, the system comprising:

means for receiving/transmitting each of (i) linearly polarized signals, and (ii) at least one of horizontally and vertically polarized signals;

means for simultaneously receiving/transmitting at least two of: (i) horizontally polarized signals; (ii) vertically polarized signals; and (iii) circularly polarized signals;

a reflective member communicatively associated with first and second lenses; and
wherein each of said first and second lenses are bifocal lenses.

[0012] In certain embodiments, the bifocal lenses each include a step portion defined in at least one edge thereof for matching purposes.

[0013] Those skilled in the art will appreciate the fact that array antennas and antennas herein are reciprocal transducers which exhibit similar properties in both transmission and reception modes. For example, the antenna patterns for both transmission and reception are identical and exhibit approximately the same gain. For convenience of explanation, descriptions are often made in terms of either transmission or reception of signals, with the other operation being understood. Thus, it is to be understood that the antenna systems of the different embodiments of this invention to be described below may pertain to either a transmission or reception

mode of operation. Those skilled in the art will also appreciate the fact that the frequencies received/transmitted may be varied up or down in accordance with the intended application of the system. Those of skill in the art will further realize that right and left-handed circular polarization may be achieved via properly summing horizontal and vertical linearly polarized elements; and that the antenna systems herein may alternatively be used to transmit/receive horizontal and vertical signals. It is also noted that the array antenna to be described below may simultaneously receive and transmit different signals.

[0014] This invention will now be described with respect to certain embodiments thereof, accompanied by certain illustrations, wherein:

IN THE DRAWINGS

[0015]

Figure 1 is a side cross sectional view of a multiple beam antenna system according to an embodiment of this invention, the system including a reflector fed dual orthogonal dielectric lens coupled to a multiple beam port low noise block down converter (LNB).

Figure 2 is a front view of the Figure 1 antenna system.

Figure 3 is a perspective view of the Figure 1-2 antenna system.

Figure 4 is an enlarged side cross sectional view of the orthogonal mode junction (OMJ) member of the Figure 1-3 embodiment.

Figure 5 is a side cross sectional view of the orthogonal mode junction of the Figure 1-4 embodiment.

Figure 6 is a cross sectional view of the Figure 4-5 orthogonal mode junction member taken along section line AA in Figure 5.

Figure 7 is a top view of the isolating member of the Figure 4-6 orthogonal mode junction member, this member performing orthogonality selection in the junction.

Figure 8 is a bottom view of a printed circuit board (PCB) from the Figure 4-6 orthogonal mode junction member, this PCB transducing horizontal components of the received or transmitted signals into or from a TEM mode electromagnetic illumination of a parallel plate waveguide connected to the junction; and wherein the base board in Figure 8 is shown in elevation form and the metal is shown in cross-section.

Figure 9 is a top view of the Figure 8 printed circuit board, with metal being shown in cross section and base board shown in an elevation manner.

Figure 10 is a drawing illustrating form and dimensions of a lens of the Figure 1-9 embodiment of this invention.

Figure 11 is a cross sectional view of the Figure 10 lens, along section line A-A.

Figure 12 is an elevational view of the Figure 10-11 lens.

Figure 13 is a cross sectional view of the Figure 10-12 lens, along section line B-B.

Figure 14 is a side view of a waveguide of the Figure 1 embodiment of this invention, the waveguide in this figure being shown in "flattened out" form for purposes of illustration (each of the waveguides are not "flat" but are instead curved as shown in Figure 1, in operative embodiments of this invention).

Figure 15 is a top view of the Figure 14 waveguide, including a lens therein.

Figure 16 is a bottom view of the RF PCB section of the three port low noise block converter (LNB) of the Figure 1 embodiment of this invention.

Figure 17 is a top view of the RF PCB section of Figure 16.

Figure 18 is a top view of the local oscillator, filter, and down converter PCB within the housing of the LNB in the Figure 1 embodiment.

Figures 19-22 are schematic diagrams illustrating different scenarios of the lenses being manipulated by the output block in order to view particular satellites.

Figure 23 is a partial cutaway perspective view illustrating the OMJ and the pair of corresponding waveguides and lenses according to an embodiment of this invention which may be used in conjunction with the reflector of the Fig. 1 embodiment.

Figure 24 is a side cross sectional view of the OMJ and waveguides of Fig. 23.

Figures 25(a)-(c) are side cross sectional views of different lenses matching techniques which may be used in any embodiment of this invention.

Figure 26 is a combination side cross sectional view and schematic of the OMJ and waveguides of

Figs 23-24.

Figure 27 is a perspective view of the reflector and OMJ which may be used in any embodiment of this invention.

Figure 28 is a side view of the Figure 1 system.

DETAILED DESCRIPTION OF CERTAIN EMBODIMENTS OF THIS INVENTION

[0016] Referring now more particularly to the accompanying drawings in which like reference numerals indicate like parts throughout the several views.

[0017] Figures 1 and 28 are side cross sectional views of a multiple beam antenna system according to an embodiment of this invention, the system including a reflector fed dual orthogonal dielectric lens coupled to a multiple beam port low noise block down converter (LNB).

[0018] For example, in this invention, the antenna system can receive linear components of circularly polarized signals from satellites, break them down and process them as different linear signals, and recreate them to enable a viewer to utilize the received circularly polarized signals.

[0019] The system is adapted to receive signals in about the 10.70-12.75 GHz range in this and certain other embodiments. The multiple beam antenna system of this embodiment takes advantage of a unique dielectric lens design, including a pair of dielectric lenses 3a and 3b to produce a high gain scanning system with few or no phase controls. Electromagnetic lenses 3a and 3b (described below) are provided in combination with a switching network so as to allow the selection of a single beam or group of beams as required for specific applications. The antenna system receives (or transmits) signals from multiple satellites simultaneously, these different satellites coexisting. The multiples signals received from the multiple satellites, respectively, split up as a function of orthogonal componentry and follow different waveguides for processing. For example, vertically polarized signals may be divided out and travel down one waveguide while horizontally polarized signals are divided out and travel down another waveguide. In such a manner, a user may tap into different signals from different satellites, e.g. horizontally polarized signals, vertically polarized signals, or circularly polarized signals. Further, a plurality of different satellites may be accessed simultaneously enabling a user to utilize multiple signals at the same time.

[0020] A unique feature is the combination of at least partially cylindrical parabolic reflective member 1 with, or operatively associated with, dielectric lenses 3a and 3b. The combination or a beam forming network with a phase array illumination of a cylindrical parabolic dish allows the antenna system to simultaneously view many satellites (e.g. up to about seven but not limited to that

number) of any polarity along their geostationary orbits. The dual lenses feed the reflective surface 1 of the dish, or vice versa. This design allows lenses 3a, 3b to simultaneously see or access more than one satellite signal (e.g. horizontal and vertical signals), and allows the system to scale system or antenna gain and G/T to performance requirements of the user. The dish or reflector 1 provides efficient or cheap variable gain (i.e. scaling to accommodate various satellite E.R.I.P. and bandwidth requirements), while the lenses provide the beamforming phase capability. The overall system may weight from only about 12-15 pounds.

[0021] The multiple beam antenna systems of the different embodiments may be used in association with, for example, DBS and TVRO applications. In such cases, an antenna system of relatively high directivity is provided and designed for a limited field of view. The system when used in at least DBS applications provides sufficient G/T to adequately demodulate digital or analog television downlink signals from high and/or medium powered Ku band DBS and FSS satellites in geostationary orbit. Other frequency bands may also be transmitted/received. The field of view may be about 32 degrees in certain embodiments, but may be greater or less in certain other embodiments.

[0022] With respect to the term "G/T" mentioned above, this is the figure of merit of an earth station receiving system and is expressed in dB/K. $G/T = G_{dBi} - 10\log T$, where G is the gain of the antenna at a specified frequency and T is the receiving system effective noise temperature in degrees Kelvin.

[0023] Referring to Figures 1-3 and 28, the antenna system includes reflector member 1. Reflector 1 has a cylindrical parabolic or any other suitable shape, wherein in certain preferred embodiments the reflector has a parabolic shape in the vertical plane and a flat or planar shape in the z-axis. Thus, reflector 1 is not parabolic in both directions, but only one, in certain embodiments of this invention. Because reflector 1 is parabolic in the vertical plane as shown, the system has a long feed assembly along a focal line due to the non-parabolic design in the z-axis. This long or elongated feed assembly of the reflector 1 along the focal line allows orthogonal mode junction (OMJ) 4 to have an elongated, substantially horizontally aligned, feed area 21 as shown in Figs. 2-3. In certain preferred embodiments, reflector 1 may be made of structural foam including a reflective metallic coating thereon. According to alternative embodiments of this invention, reflector 1 may be formed as a reflective surface of the waveguide 11.

[0024] The provision of reflector 1 in combination with dielectric lenses 3a and 3b allows the antenna system of certain embodiments of this invention to receive signals from satellites emitting either horizontally polarized signals or vertically polarized signals as will be discussed below. Horizontally and vertically polarized signals are orthogonal to one another as is known in the

art. Furthermore, this invention in alternative embodiments may enable the user to receive signals from satellites emitting either left or right handed circularly polarized signals, as left and right handed circularly polarized signals are also orthogonal to one another.

[0025] The antenna system also includes first and second waveguides 10 and 11 which are collectively numbered 2. These two waveguides are aligned substantially parallel to one another, and each includes two parallel conductive surfaces spaced apart from one another (e.g. by about 3/8"). Waveguides 10 and 11 provide the radial TEM wave guide mode from corresponding lenses 3a and 3b, as they are both TEM mode radial guides. Each waveguide 10 and 11 includes two sections, one section located between OMJ 4 and the corresponding lens 3a, 3b, and another section disposed between the corresponding lens and LNB 5. Each waveguide may be made of any suitable material (e.g. stainless steel) and have, in certain embodiments, a conductive reflective aluminum or copper metal coating (i.e. low loss surface). Waveguides 11 and 10 allow microwaves from lenses 3a and 3b to focus on different output portions of LNB 5 corresponding to selectable different satellite locations. Two waveguides are needed because one is used to carry or convey each of the two orthogonal polarities, i.e. guide 10 carries one polarity and guide 11 the other polarity.

[0026] Dielectric lenses 3a, 3b are identical to one another in certain embodiments of this invention. Lenses 3a and 3b are fed orthogonally, as one lens 3a facilitates one polarity (e.g. horizontal) while the other lens 3b facilitates an orthogonal polarity (e.g. vertical). In certain embodiments, each lens 3a, 3b may be made of crystalline polystyrene or alternatively of polyethylene.

[0027] Mount 6 supports parallel waveguides 10, 11, as well as lenses 3a, 3b, reflector 1, and junction 4. Antenna mount assembly enables elevational adjustment, azimuthal adjustment, and rotational adjustment of the reflector 1 and feed 21 about the Clark belt.

[0028] Unique orthogonal mode junction 4, having feed area 21, receives linear signals from reflector 1, and separates the horizontally polarized signals from the vertically polarized signals, and places or directs them in corresponding separate parallel plate TEM waveguides 10 and 11 in order to illuminate dielectric lenses 3a and 3b. In other words, satellite signals, from a plurality of different satellites, are received by reflector 1 and are reflected into feed 21 of orthogonal mode junction (OMJ) 4 in the form of microwave signals. Junction 4 divides out vertically polarized microwave signals from horizontally polarized microwave signals, and forwards one polarity signal into waveguide 10 and the other polarity signal into waveguide 11. Thus, one lens 3a is illuminated by the vertical polarization sense (or e.g. left handed) and the other lens 3b is illuminated by the horizontal polarization sense (or e.g. right handed). An important feature of OMJ 4 is that the feedhorn has

the ability to accommodate the focal line of cylindrical parabolic reflector 1 and is also able to feed first and second parallel plate TEM-mode waveguides 10, 11, and first and second dielectric lenses 3a and 3b. The parallel plate orthogonal mode junction in combination with lenses 3a, 3b and the parabolic reflector provide the advantages discussed herein.

[0029] From lenses 3a and 3b, the microwave signals propagate or travel down their respective waveguides 10 and 11 to multiple beam port low noise block converter (LNB) 5. LNB 5 includes printed circuit boards (PCBs) [shown in Figs. 16-18] positioned within a housing. LNB 5 is responsible from selecting the specific satellite(s) of interest to the user and configuring the polarities of linear (horizontal and vertical) and circular (right and left hand of choice).

[0030] In certain embodiments of this invention, OMJ 4 may be made of extruded aluminum, or any other suitable material. Also, impedance matching steps 27 are provided within the interior of OMJ 4 for impedance matching purposes (i.e. waveguide transformers).

[0031] Figure 2 is a front view of the Figure 1 antenna system. As shown in Figure 2, feed 21 of OMJ 4 is elongated in design so as to correspond to a focal line of the reflector which is substantially parallel thereto. Figure 3 is a perspective view of the Figure 1-2 system. Also illustrated in Figure 3 are endcaps 23 located along the elongated and curved edges of the waveguides.

[0032] Figure 4 is an enlarged side cross sectional view of the orthogonal mode junction (OMJ) member 4 of the Figure 1-3 embodiment. Elongated rods 8, provided in the OMJ, may be from about 0.040 to 0.060 inches in diameter (preferably in this embodiment about 0.050 inches in diameter). Isolating rods 8 are configured within the housing of OMJ 4 so as to isolate the horizontally polarized component of the received (or transmitted) signal that comes into feed 21 from waveguide 10 to waveguide 11. Meanwhile, isolating board 12 in OMJ 4 isolates the vertical component of the received (or transmitted) signal from waveguide 11 to waveguide 10. Isolator 12 in certain embodiments may be fabricated of 0.0050 (5 mil) inch thick beryllium copper (or plane copper) in order to perform its isolation function. Figure 7 is a top view of isolator 12, illustrating the grid assembly responsible for sorting out the orthogonal signals with rods 8.

[0033] Transducer board 9, shown in Figure 9 as part of OMJ 4, may be a printed circuit board (PCB) fabricated on 0.020 inch thick Teflon fiberglass in certain embodiments. Metal transducers on PCB 9 transduce the horizontal component of the received (or transmitted) signal into a TEM mode electromagnetic illumination of parallel plate waveguide 11. Figure 8 is a bottom view of transducer board 9 while Figure 9 is a top view of board 9, with the metallic transducers being shown in cross section.

[0034] OMJ 4 further includes radome 7 which has traditional radome characteristics such as protection, in

order to accommodate the feed assembly.

[0035] Figures 5 and 6 further illustrate OMJ 4, with Figure 6 being a sectional view along section line AA. As shown, each of components 8, 9, and 12 are substantially parallel to one another, and are substantially elongated in design. Each of elements 8, 9, and 12 is substantially as long as feed 21 of the OMJ.

[0036] Figures 10-13 illustrate one of dielectric lenses 3a or 3b according to an embodiment of this invention. In certain preferred embodiments, both optical lenses are identical, but may be different in other alternative embodiments. One lens is provided for each orthogonal mode, e.g. one for vertical signals and one for horizontal signals. The lenses according to this invention can receive/transmit linear or circularly polarized signals simultaneously.

[0037] Figures 14-15 illustrate sectorial feedhorns 13 within one of waveguides 10, 11. It is noted that while Figure 14 illustrates the waveguide as being "flat" for purposes of simplicity, it really is not flat in practice [note the curved banana-shaped configuration of each waveguide 10, 11 in Figure 1]. Feedhorns 13 are positioned within the waveguides so as to accommodate the orbital locations of the satellites of interest within the geostationary Clark belt. These focused horns 13 receive the focused signals from the corresponding dielectric lens 3a, 3b of the polarity of the corresponding lens. The configurations, quantity or number, and position of feedhorns 13 correspond to the number of satellites to be accessed or used. The outputs 31 of the feedhorns are coupled to the LNB circuit boards shown in Figures 16-18, through rectangular waveguides 33 of the WR-75 type.

[0038] Still referring to Figure 15, from right to left, the microwave signals coming out of the lens 3a, 3b (when receiving satellite signals) propagate down the waveguide toward and into feedhorns 13. Lines 39 illustrate the scanning angle, provided by each feedhorn, of the different satellites (3 in this embodiment) to be accessed or used. As the positions of the feedhorns dictate which satellites are to be used, it is noted that there is a 15 degree difference in the location of the satellite corresponding to the uppermost feedhorn 33 and the middle feedhorn 33, while there is only a 7.5 degree difference in the position of the satellite corresponding to the middle feedhorn and the lowermost feedhorn 33. Thus, sectorial feedhorns 33 accommodate the satellites of interest. It is also noted that feedhorns 13 as shown in Figures 14-15 are sandwiched between a pair of upper and lower plates that of the corresponding waveguide, which are not shown.

[0039] The LNB 5 housing contains the two circuit boards shown in Figures 16-18. These boards perform the following functions: low noise RF amplification, down converts from RF to IF, selects IF frequency and number of IFs, selects satellites of interest as dictated by the user, selects polarity (linear (hor. or vert.) or circular [right-hand CP or left-hand CP]) of interest, switch

matrix for multiple outputs or multiple IFs, IF amplification, converts WR-75 to circuit board strip-line waveguide, compensates for polarity skew in various geographic locations, and may be an antenna to set-top-box interface.

[0040] Figures 19-22 illustrate how lenses 3a, 3b may be utilized to access different types of signals according to certain embodiments of this invention. For a more detailed description, see U.S. Pat. No. 5,495,258, the disclosure of which is incorporated herein by reference.

[0041] While in preferred embodiments, each lens deals with a linearly polarized signal (either hor. or vert.), in certain embodiments, circularly polarized signals may also be accessed and utilized. In accordance with the above described lens designs, the lenses in combination of the multiple beam antenna systems of this invention allow the systems to select a single beam or a group of beams for reception (i.e. home satellite television viewing). Due to the design of the antenna array and matrix block (including the array of antenna elements of the inventions herein), right-handed circularly polarized satellite signals, left-handed circularly polarized satellite signals, and linearly polarized satellite signals within the scanned field of view may be accessed either individually or in groups. Thus, either a single or a plurality of such satellite signals may be simultaneously received and accessed (e.g. for viewing, etc.).

[0042] Figure 19 illustrates the case where the user manipulates satellite selection matrix to simply pick up the signal from a particular satellite which is transmitting a horizontal signal. In such a case, the path length in lens 3a is adjusted so as to tap into the signal of the desired satellite.

[0043] Figure 20 illustrates the case where a plurality of received outputs from lens 3b are summed or combined in amplitude and phase. The signals from two adjacent outputs 65 are combined at summer 71 so as to split the beams from the adjacent output ports 65. Thus, if the viewer wishes to view a satellite disposed angularly between adjacent output ports 65, output block 69 takes the output from the adjacent ports 65 and sums them at summer 71 thereby "splitting" the beam and receiving the desired satellite signal. It is noted that a small loss of power may occur when signals from adjacent ports 65 are summed in this manner.

[0044] Figure 21 illustrates the case where outputs 65 from both lenses are tapped (in a circular embodiment as described in the '258 patent) so as to result in the receiving of a signal from a satellite having circular (or linear) polarization.

[0045] Figure 22 illustrates the case where it is desired to access a satellite disposed between the beams of adjacent ports 65 wherein the satellite emits a signal having circular (or linear) polarization. Adjacent ports 65 are accessed in each of lenses and are summed accordingly at summers 75. Thereafter, phase shifter 73 adjusts the phase of the signal from one lens and the signals from the lenses are combined at sum-

mer 71 thereafter outputting a signal from output block 69 indicative of the received circular polarized signal.

[0046] Once given the above disclosure, therefore, various other modifications, features or improvements will become apparent to the skilled artisan. Such other features, modifications, and improvements are thus considered a part of this invention, the scope of which is to be determined by the following claims. For example, the above-discussed multiple beam antenna system can receive singularly or simultaneously any polarity (circular or linear) from a single or multiple number of satellites, from a single or multiple number of beams, knowing that co-located satellites utilize frequency and/or polarization diversity.

[0047] In certain alternative embodiments of this invention, microwave dielectric lenses 3a and 3b for multibeam or scanning applications may have a bifocal design used in combination with Abbe Sine design methodology. This increases the scanning angle of the lens. Figures 23, 24, 25(a) and 26 illustrate lenses 3a and 3b having a bifocal design with a "step" offset 91 on the edges of the lenses closest to OMJ 4 and another step offset 92 on the opposite edge of the lenses farthest from the OMJ. A collimating lens was designed to be coma free for a limited scan by imposing the known Abbe Sine condition. By constructing a plano-convex lens with a dielectric constant from about 2.4 to 2.7 (preferably about 2.55), a coma free beam over an angular coverage of plus/minus eight beam widths, with side lobe performance lower than about -18 dB, was achieved.

[0048] The bifocal methodology of establishing two approximately perfect foci in the principal plane for two off-axis beams was combined with the Abbe Sine condition methodology for the lenses 3a and 3b shown in Figures 23-26. This slightly diminished the performance of other beams which lie between the two foci by increasing the side lobes less than about 1 dB. Surprisingly, an increase in off-axis performance resulted to more than about plus/minus ten (10) beam widths with side lobes lower than -21 dB.

[0049] Further improvement in side lobe performance of dielectric lenses herein may be accomplished by matching it to the parallel plate TEM radial waveguide environment of the lens that will be used. A simplified matching technique is desired to accommodate low cost, high volume, manufacturing of antenna systems disclosed herein. In matching, the shape of surfaces of the lenses results in the canceling of surface reflections which may cause a decrease the gain of the antenna system due to increases in side lobe level and input standing-wave ratio. The two surfaces or edges of a lens which are exposed to the transverse E-plane wave are the surfaces that benefit from matching.

[0050] Figures 25(a)-(c) illustrate bifocal lenses 3a, 3b according to different embodiments of this invention, located within a parallel plane of the surrounding TEM waveguide. Each lens includes a first major surface

located proximate or adjacent one of the conductive waveguide surfaces which defines the waveguide within which the lens is located, and a second major surface located proximate the opposing waveguide conductive surface. In the Fig. 25(a) embodiment (also shown in Figs. 23, 24 and 26), the lens 3a (or 3b) includes steps 91 and 92 on opposite edges thereof. Each step 91, 92 includes a first vertical portion 93 which is oriented approximately perpendicular to the adjacent waveguide surface, a second horizontal surface 94 which is approximately parallel to each of the opposing waveguide surfaces, and a third vertical portion 95 which is approximately perpendicular to portion 94 and to the adjacent waveguide surface. The planar portion of the lens whose outer periphery is defined by portions 93 has a larger volume and larger surface area adjacent the immediately adjacent waveguide surface than the planar portion of the lens whose periphery is defined by portions 95. Thus, the Fig. 25(a) lens includes two planar portions which are either integrally formed with one another, or which may be laminated to one another in some embodiments.

[0051] The Fig. 25(b) lens 3a, 3b may be used in other embodiments of this invention. This lens includes a slot 96 defined in the opposing edges of the lens for matching purposes. In addition to the square slot shown in Fig. 25(b), slots of other shapes may instead be used, such as rectangular, oval, and the like.

[0052] The Figure 25(c) lens 3a, 3b may be used in other embodiments of this invention, and includes a plurality of approximately parallel slots defined in the opposing edges of the lens for matching purposes. For example, three slots 97 are shown in each of the opposing edges in Fig. 25(c), although from two through twenty slots may be provided in each edge in different embodiments of this invention. However, it is noted that the Fig. 25(a) lens has been found to be easier to manufacture, have lower tolerances, and a higher level of ruggedness and is thus preferred in certain embodiments of this invention for use in volume production.

[0053] Referring now to OMJ 4 of Figures 23, 24, and 26, the OMJ of this embodiment is used in conjunction with the illustrated parallel plate TEM radial waveguides. The OMJ design enables the use of a single feedhorn which performs as a linear array, with element spacing infinitesimally small, that may be aligned to a focal line of the cylindrical parabola reflector 1. The long or elongated feed assembly of the reflector along the focal line allows OMJ 4 to have an elongated, approximately horizontally aligned, feed 21 as shown in Figs. 2 and 27. OMJ 4 in turn delivers signals to the two parallel plate dielectric lenses 3a, 3b in a way that both are electrically orthogonal to one another. This is unlike the prior art, because in the prior art junctions for waveguides are single circular or rectangular (square) wave guides with a multiplicity of them used to feed a parallel plate guide. Thus, the instant OMJ is an improvement over traditional techniques which are more complicated and

expensive to manufacture. Furthermore, conventional junctions would have to be configured as a multiplicity of elements and their spacing would cause grating lobes and the individual feed patterns would dictate scanning loss for off axis performance.

[0054] Referring still to Figs. 23, 24, and 26, the multiple different signals received from the multiple satellites by the illustrated antenna system (e.g. simultaneously or otherwise), respectively split up as a function of their different orthogonal components (e.g. horizontal and vertical), with the different orthogonal components following different waveguides 10, 11 for processing. For example, vertically polarized signals may be divided out and caused to travel down one waveguide while horizontally polarized signals are divided out and caused to travel down the other waveguide. In such a manner, a user may tap into different signals from different satellites, e.g. horizontally polarized signals, vertically polarized signals, or circularly polarized signals. Also, a plurality of different satellites may be accessed simultaneously enabling a user to utilize multiple signals at the same time. Additionally, this invention may enable the user to receive signals from satellites emitting either left or right handed circularly polarized signals, as these signals are also orthogonal to one another.

Claims

1. A multiple beam antenna system including bifocal lenses, for simultaneously receiving signals of different polarity that are orthogonal to one another, the system comprising:
 - a reflective member communicatively associated with first and bifocal second lenses, said reflective member and said first and second lenses for forwarding said first signal of a first polarity into a first waveguide and said second signal of a second polarity into a second waveguide; and
 - wherein each of said first and second lenses includes a step portion defined in an edge thereof.
2. The antenna system of claim 1, wherein said antenna system is designed to receive satellite television signals from about 10.7-13 GHz, and wherein said system can simultaneously receive horizontally polarized signals and vertically polarized signals.
3. The system of claim 1, wherein each of said bifocal lenses includes a first step on a first edge thereof and a second step on a second opposing edge thereof.
4. The system of claim 1, wherein each of said bifocal lenses includes first and second parallel planar portions, wherein said first planar portion is larger than said second planar portion, with at least one step on an edge of each of said lenses defining an amount by which said first planar portion is larger than said second planar portion, and wherein each of said lenses consists essentially of said first and second planar portions.
5. The system of claim 1, wherein each of said lenses is disposed between approximately parallel opposing conductive waveguide surfaces.
6. The system of claim 5, wherein the step portion in each lens includes a first wall that is approximately perpendicular to a first one of said parallel conductive waveguide surfaces, a second wall that is approximately perpendicular to a second one of said parallel conductive waveguide surfaces, and a third wall that interconnects said first and second walls.
7. A multiple beam antenna system comprising:
 - a reflective member that is substantially parabolic in at least one dimension;
 - a junction for receiving microwave signals from the reflective member;
 - first and second dielectric lenses in communication with said junction member, each of said dielectric lenses having one of (i) a step, and (ii) a notch, defined in an edge thereof;
 - first and second waveguides in communication with said first and second lenses, respectively;
 - wherein said junction receives microwave energy including a first signal having a first polarity and a second signal having a second polarity from said reflective member;
 - wherein said junction causes said first signal having said first polarity to be forwarded to said first lens and said second signal having said second polarity to be forwarded to said second lens, wherein said first and second polarities are different; and
 - wherein a signal resulting from said signal of said first polarity exits said first lens and proceeds down said first waveguide, and a signal resulting from said signal of said second polarity exits said second lens and proceeds down said second waveguide so that a user can receive signals of different polarity from different satellites.
8. The antenna system of claim 7, wherein said first and second polarities are substantially orthogonal to one another.
9. The antenna system of claim 7, wherein each of

said lenses includes a matched step defined in an edge thereof, and wherein a first wall of said step is oriented approximately parallel to a first wall of one of said waveguides and a second wall of said step is oriented approximately perpendicular to said first wall of said step.

10. The antenna system of claim 7, wherein said reflective member is substantially parabolic in shape in the vertical plane and is substantially flat in the z-axis.

11. The antenna system of claim 7, wherein said first and second waveguides are substantially parallel to one another throughout their entire respective lengths, and wherein each of said waveguides is bent or angled so that first and second sections of said waveguides extend in different directions, and wherein said different directions are different from one another by an angles of from about 45 to 150 degrees.

12. A dielectric matching lens for use in a multibeam antenna system, the dielectric matching lens comprising:

a first major surface adapted to be positioned proximate a waveguide surface and a second major surface adapted to be positioned proximate an opposing waveguide surface;

at least one edge connecting said first and second major surfaces; and

a step defined in said at least one edge, said step including first, second, and third portions in an area thereof, wherein said second portion is oriented approximately perpendicular to said first and third portions and wherein said second portion interconnects said first and third portions.

13. The lens of claim 12, wherein said first portion interconnects said second portion and said first major surface, and said third portion interconnects said second portion and said second major surface.

14. The lens of claim 13, wherein said first portion is approximately perpendicular to said first major surface and said third portion is approximately perpendicular to said second major surface.

15. The lens of claim 12, wherein said step is configured for matching so as to minimize adverse effects of reflections off of the lens.

16. The lens of claim 12, wherein the lens is bifocal.

17. A multiple beam antenna system for simultaneously receiving signals of different polarity that are orthogonal to one another, the system comprising:

means for receiving each of first and second polarized signals that are orthogonal to one another;

means for simultaneously receiving said first and second signals; and

a parabolic reflective member communicatively associated with first and second lenses, said reflective member and said first and second lenses for forwarding said first signal of a first polarity into a first waveguide and said second signal of a second polarity into a second waveguide.

18. The antenna system of claim 17, wherein said antenna system is designed to receive satellite television signals from about 10.7-13 GHz, and wherein said system can simultaneously receive horizontally polarized signals and vertically polarized signals, and wherein said first signal is horizontally polarized and said second signal is vertically polarized.

19. The system of claim 17, further including means for simultaneously receiving both circularly polarized signals and linearly polarized signals and outputting said simultaneously received signals to a user.

20. The system of claim 17, further including means for simultaneously receiving multiple beams and multiple polarities of the circular and linear type.

21. A multiple beam antenna system comprising:

a reflective member that is substantially parabolic in at least one dimension;

a junction for receiving microwave signals from the reflective member;

first and second dielectric lenses in communication with said junction member;

first and second waveguides in communication with said first and second lenses, respectively;

wherein said junction receives microwave energy including a first signal having a first polarity and a second signal having a second polarity from said reflective member;

wherein said junction causes said first signal having said first polarity to be forwarded to said first lens and said second signal having said second polarity to be forwarded to said second lens, wherein said first and second polarities are different; and

wherein a signal resulting from said signal of said first polarity exits said first lens and proceeds down said first waveguide, and a signal

resulting from said signal of said second polarity exits said second lens and proceeds down said second waveguide so that a user can receive signals of different polarity from different satellites;

22. The antenna system of claim 21, wherein said first and second polarities are substantially orthogonal to one another.

23. The antenna system of claim 21, wherein said first polarity is substantially horizontal and said second polarity is substantially vertical, and wherein said first and second waveguides are substantially parallel to one another along at least one portion thereof.

24. The antenna system of claim 21, wherein said reflective member is substantially parabolic in shape in the vertical plane and is substantially flat in the z-axis.

25. The antenna system of claim 21 wherein said first and second waveguides are substantially parallel to one another throughout their entire respective lengths, and wherein each of said waveguides is bent or angled so that first and second sections of said waveguides extend in different directions, and wherein said different directions are different from one another by an angles of from about 45 to 150 degrees.

26. The antenna system of claim 21 wherein said junction includes an elongated feed area that receives signals from said reflective member.

27. The antenna system of claim 26, wherein said junction includes impedance matching steps defined by at least one wall thereof.

28. The antenna system of claim 26, wherein said junction includes a plurality of elongated members extending across a signal path that function to separate signals of different polarity from one another.

29. The antenna system of claim 28, wherein said elongated members are rods.

30. The antenna system of claim 28, wherein said junction includes a transducer for transducing a particular polarity component of a received signal into a TEM mode electromagnetic illumination of one of said waveguides.

31. The antenna system of claim 28, wherein said transducer includes a plurality of metallic transducers and said junction is made of an extruded metal.

32. The antenna system of claim 26, wherein said junction is in communication with a pair of waveguides that allow said junction to communicate with said first and second lenses.

33. An antenna system comprising:

an orthogonal mode junction for simultaneously receiving each of first and second polarized signals, of first and second different polarities respectively, that are orthogonal to one another;

said orthogonal mode junction forwarding signals of the first polarity into a first waveguide and signals of the second polarity into a second waveguide.

34. The antenna system of claim 33, wherein said antenna system is designed to receive satellite television signals from about 10.7-13 GHz, and wherein said system can simultaneously receive horizontally polarized signals and vertically polarized signals, and wherein said first signals are horizontally polarized and said second signals are vertically polarized.

35. An orthogonal mode junction for use in a multibeam antenna system, the junction comprising:

a housing;

a feed area for simultaneously receiving first signals of a first polarity and second signals of a second polarity which is orthogonal to the first polarity;

isolating means within said housing for isolating said first signals from said second signals;

a first channel through which the first signals of the first polarity travel toward and into a first waveguide;

a second channel through which the second signals of the second polarity travel toward and into a second waveguide; and wherein said isolating means causes said first signals of said first polarity to be forwarded into the first channel and the second signals of the second polarity to be forwarded into the second channel.

36. The junction of claim 35, wherein said isolating means includes a plurality of elongated rods.

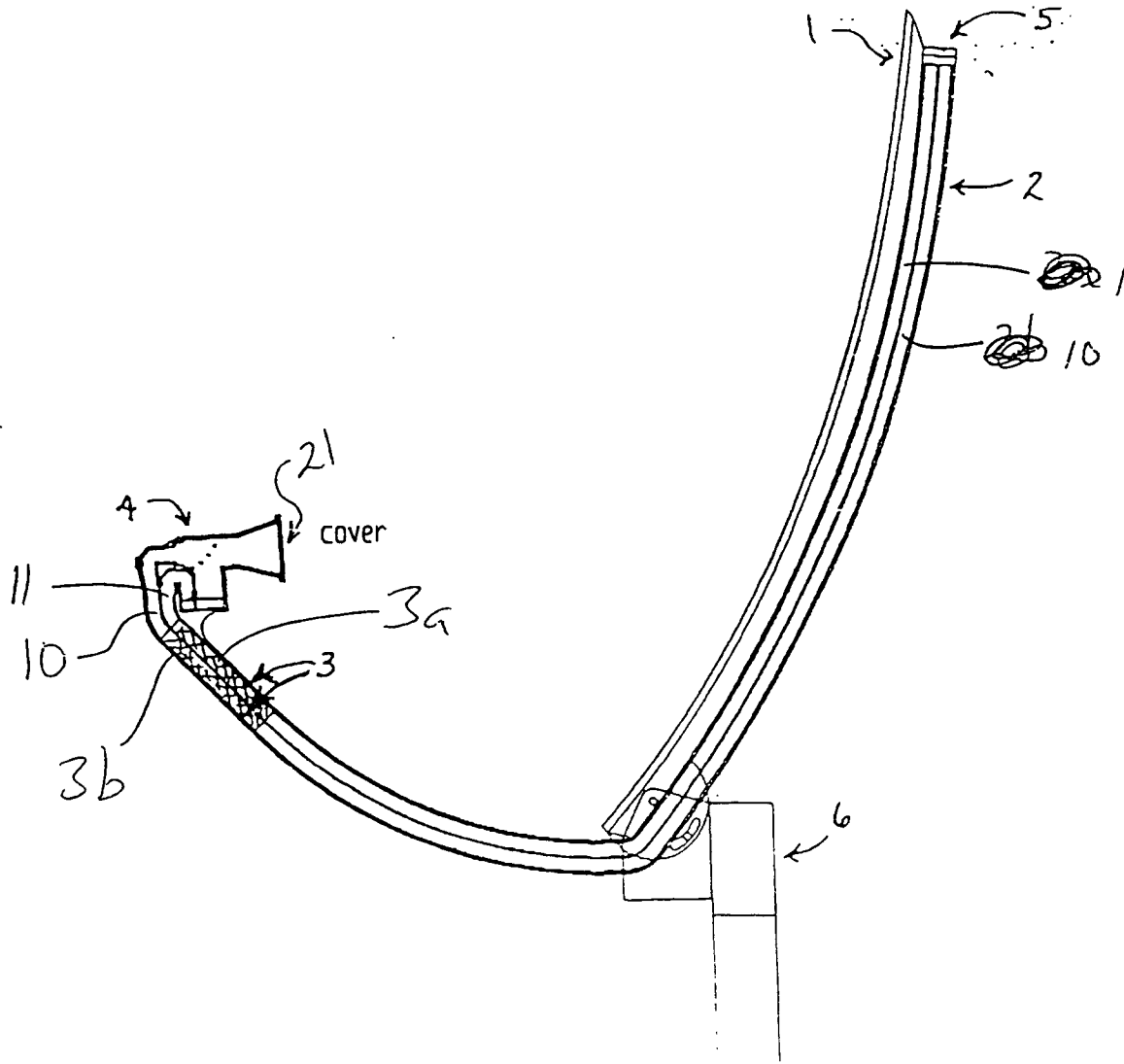
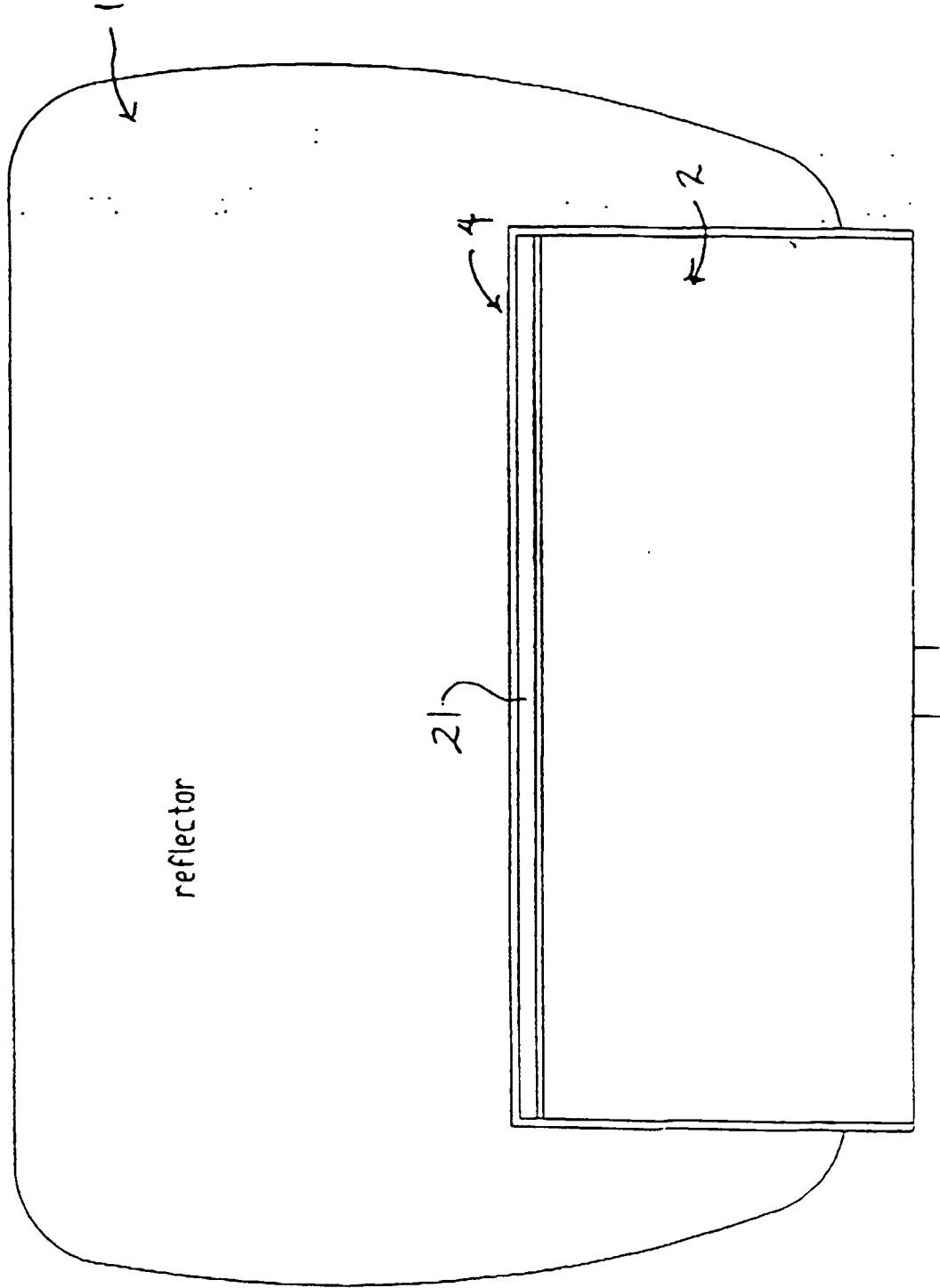

FIG. 1

FIG. 2



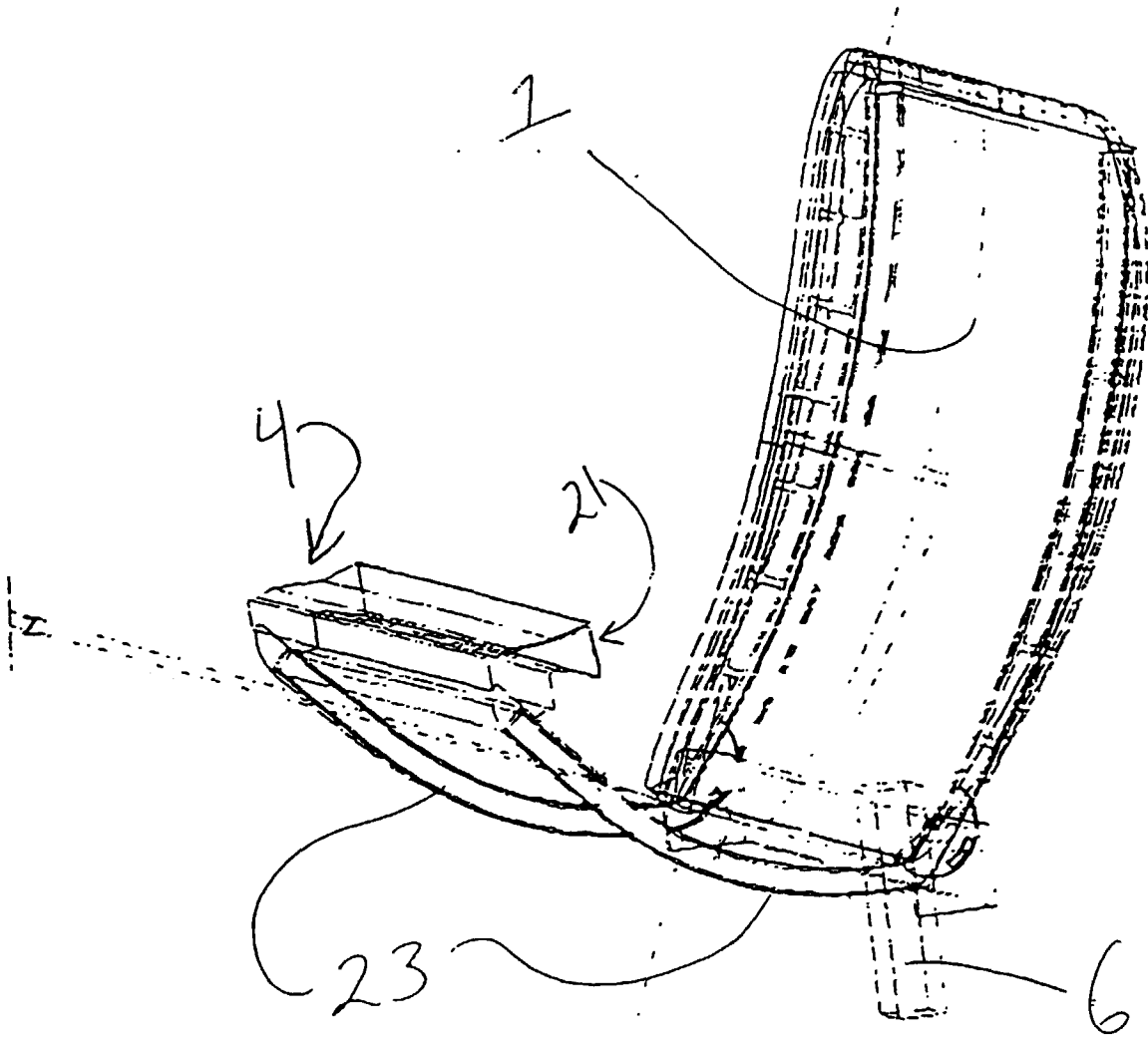
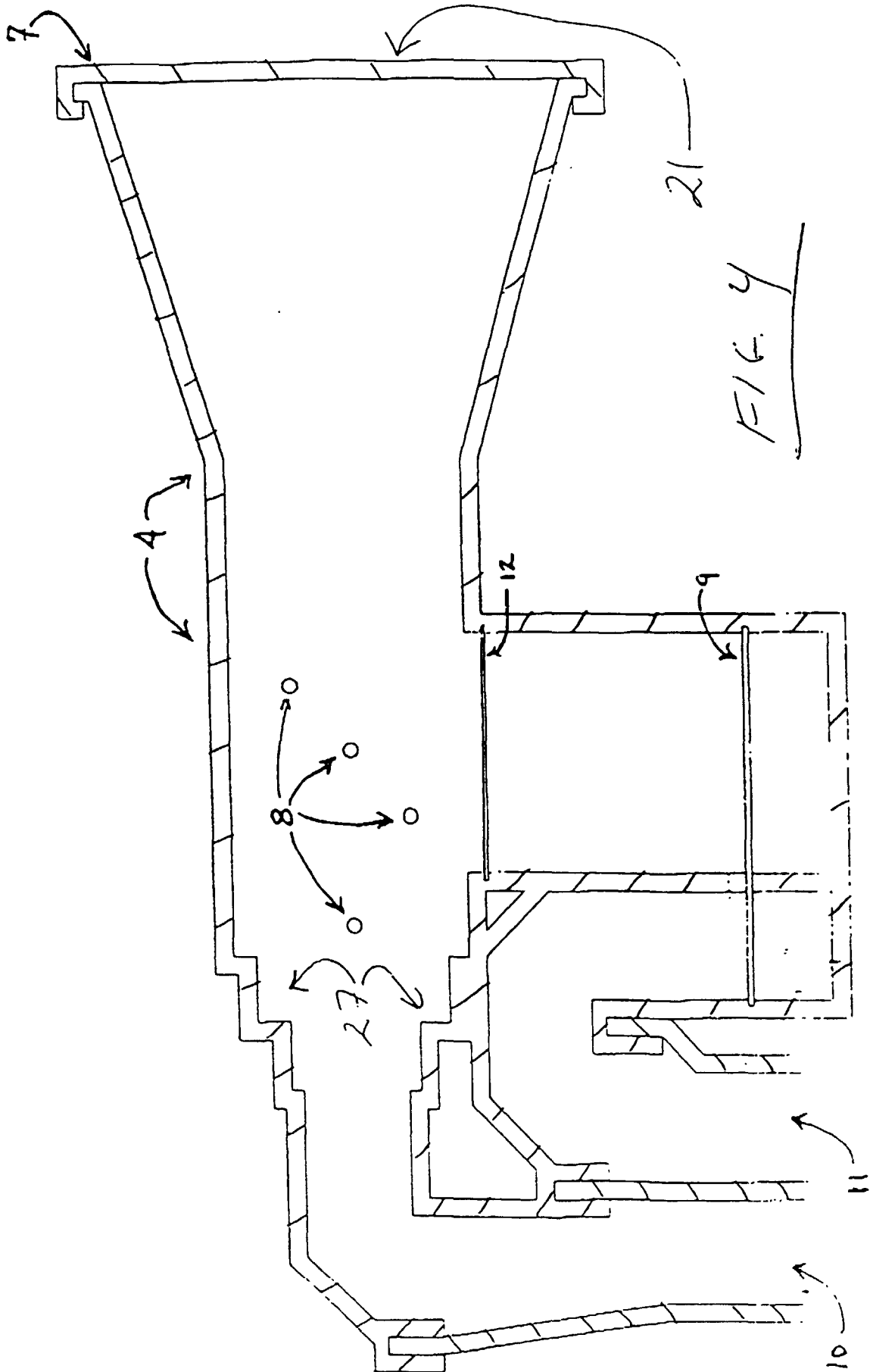

FIG. 3



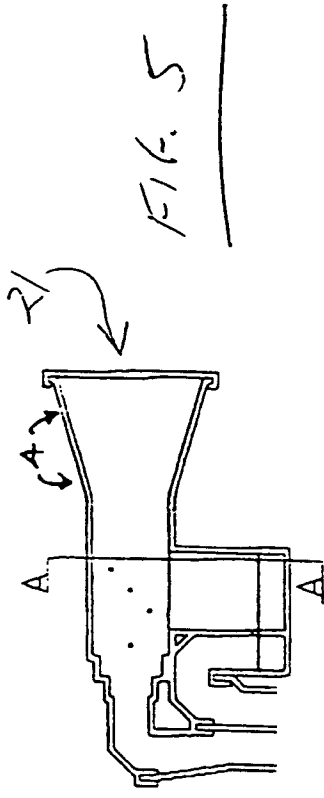
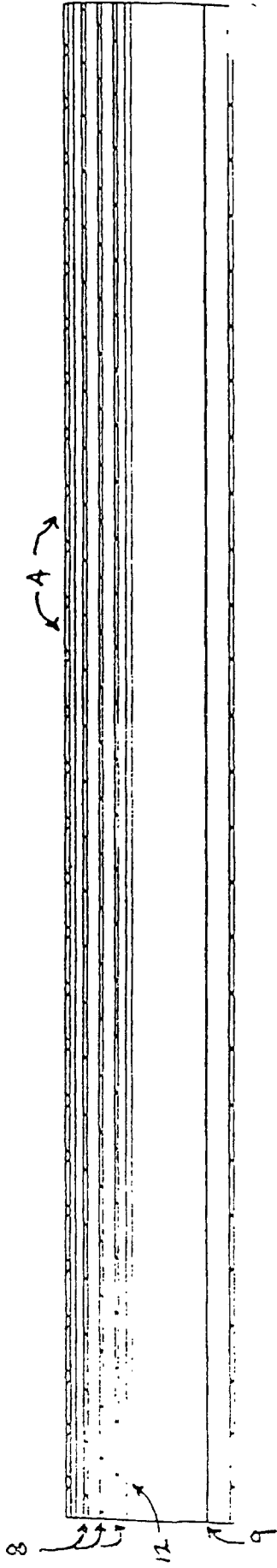

FIG. 5



SECTION AA

FIG. 6

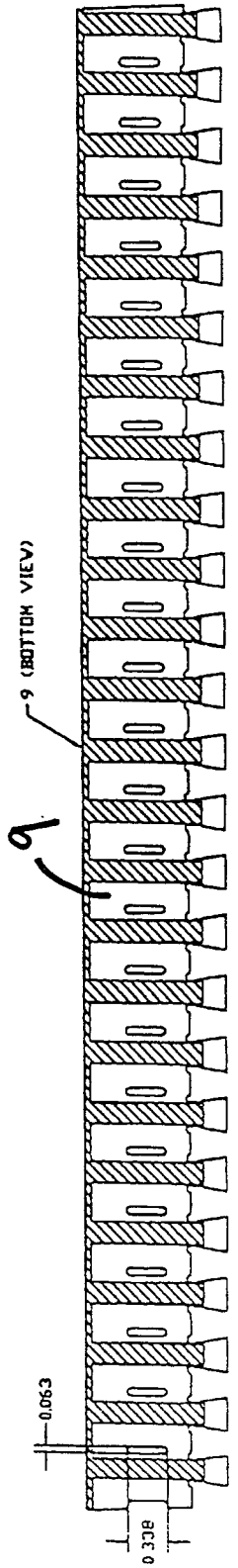
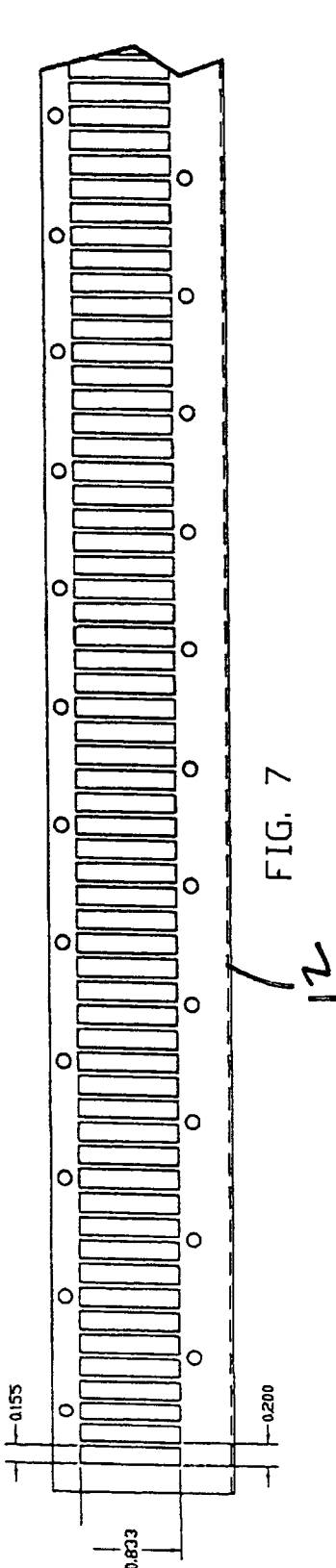

FIG. 8

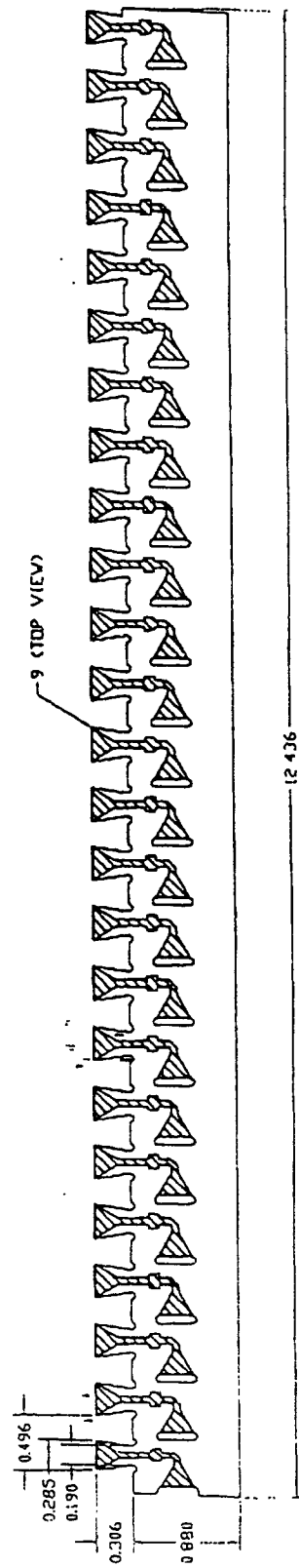
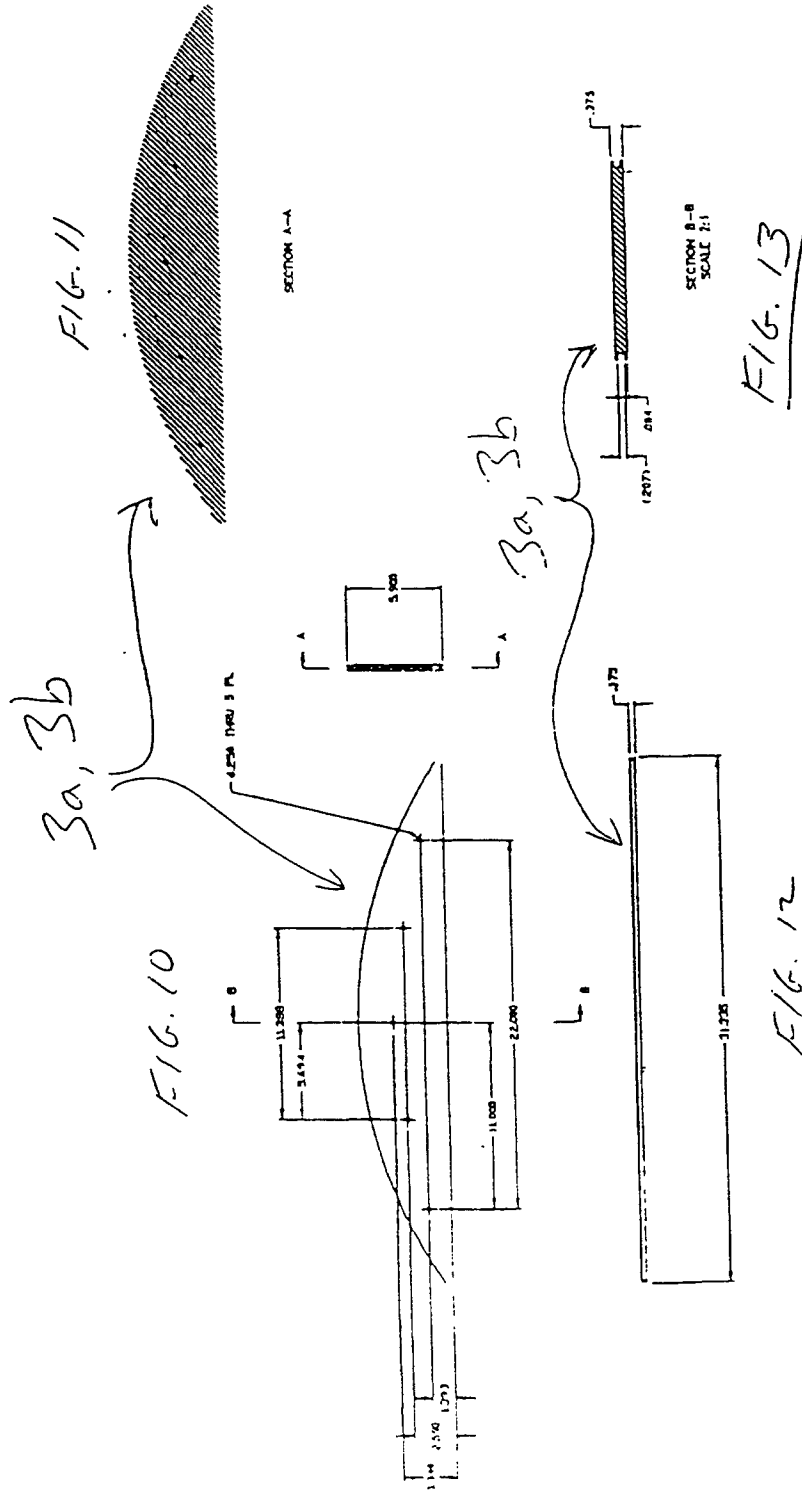
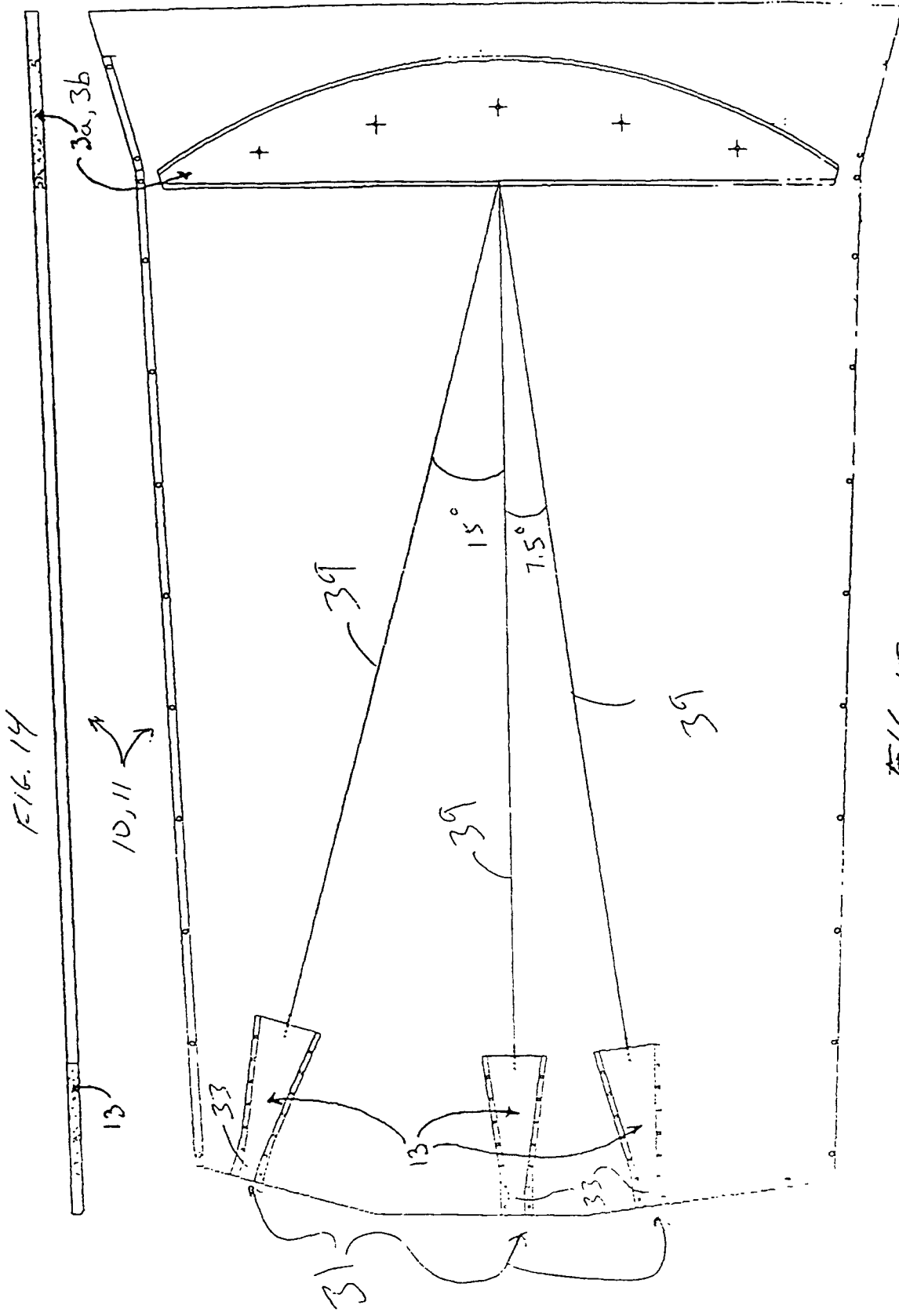

FIG. 9

Dielectric Lens





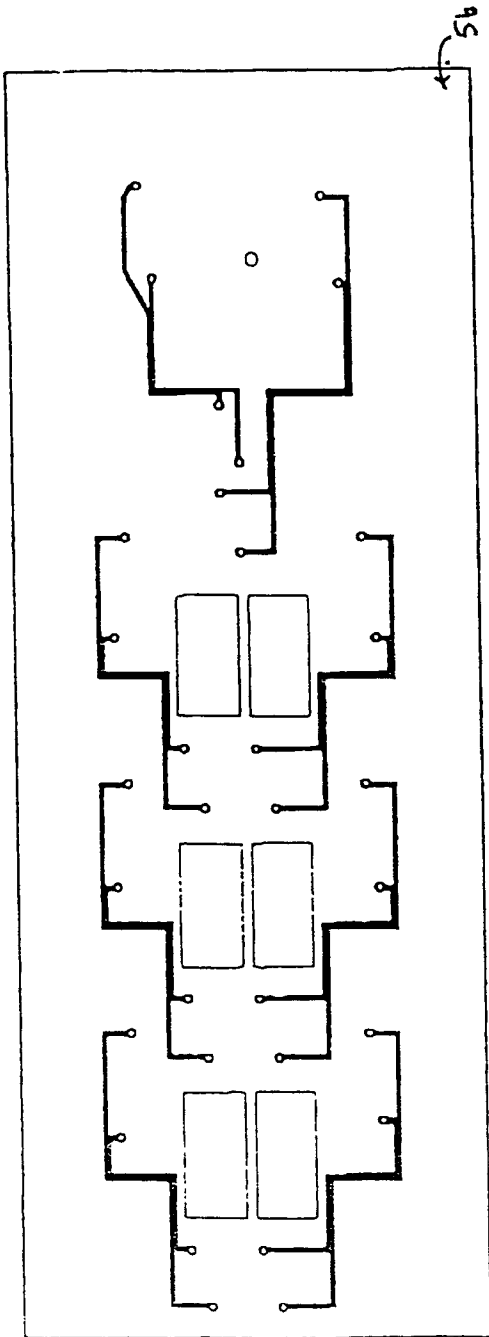

Fig. 16

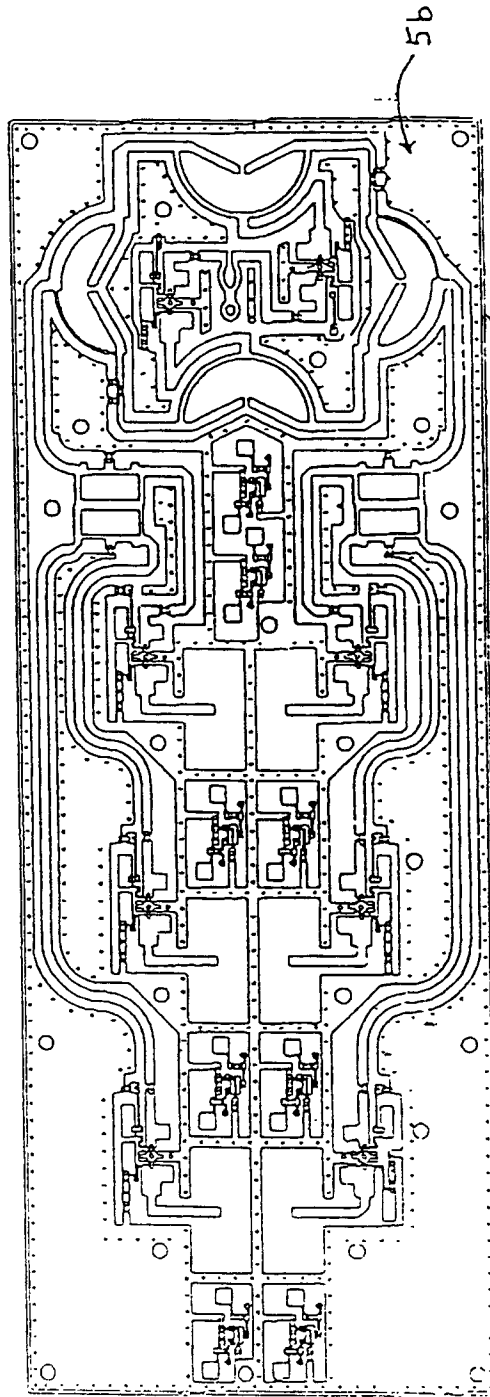
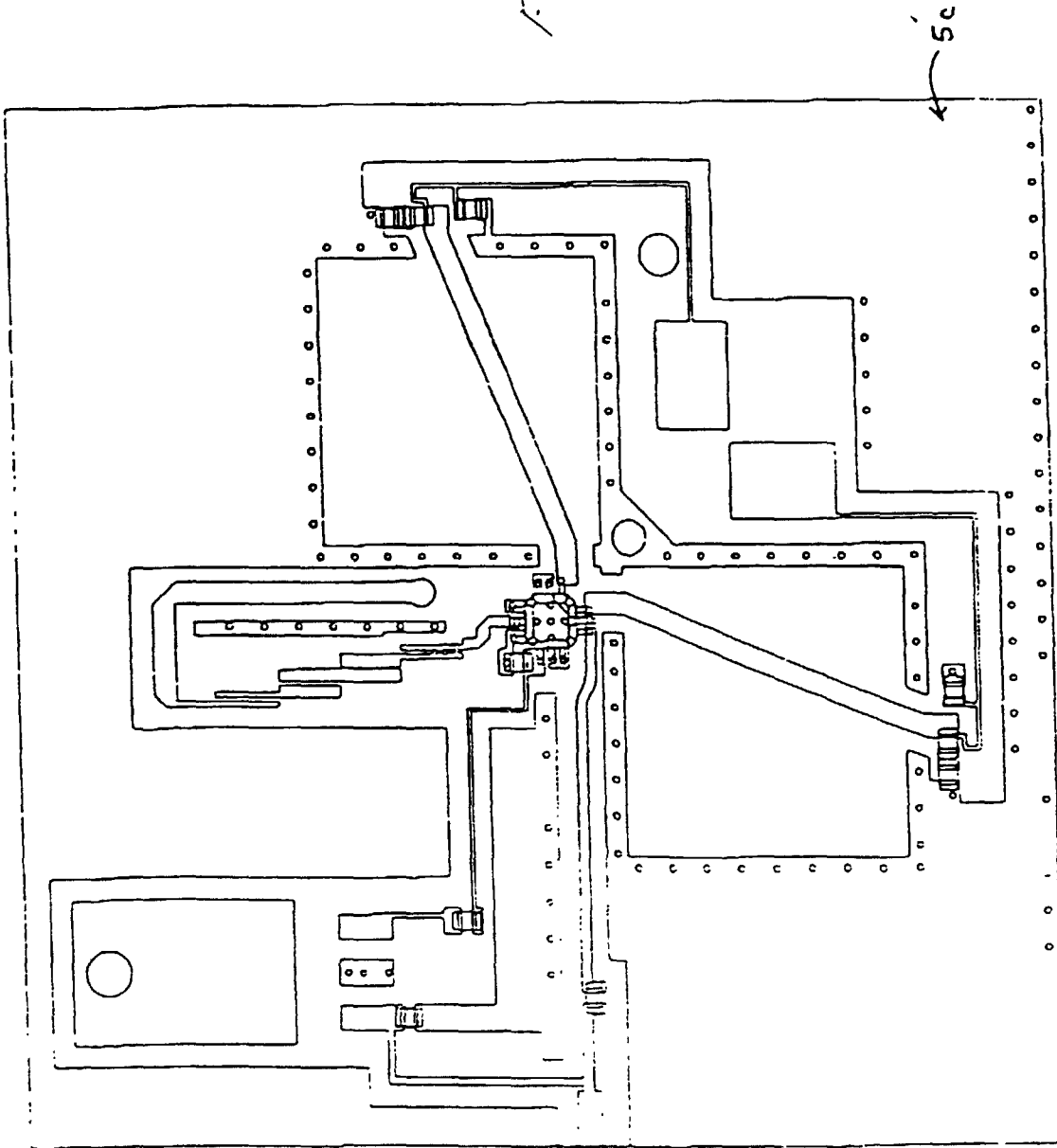
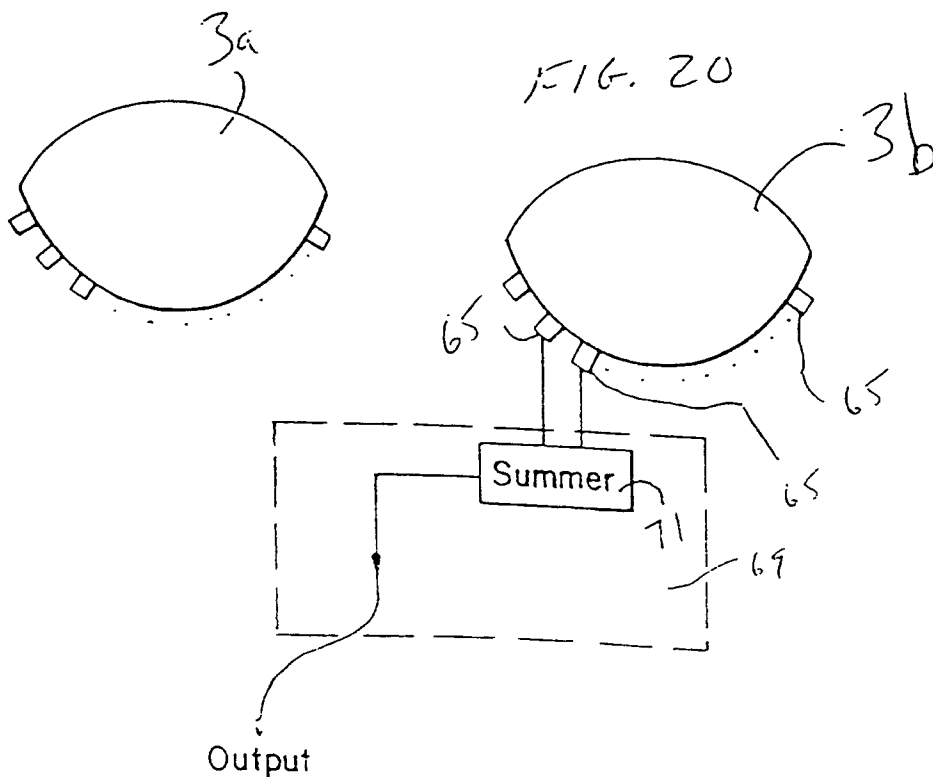
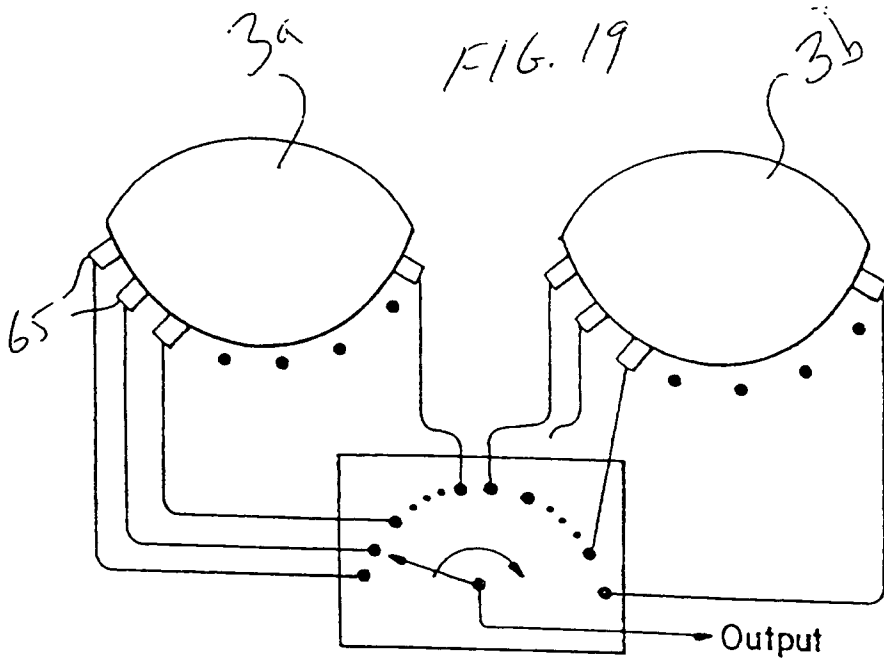
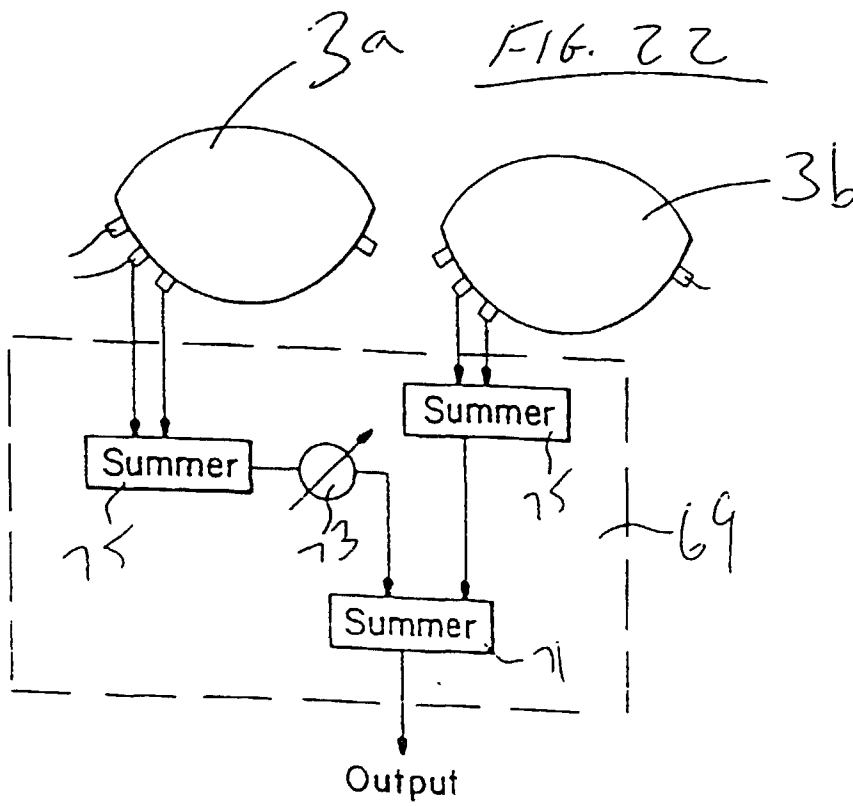
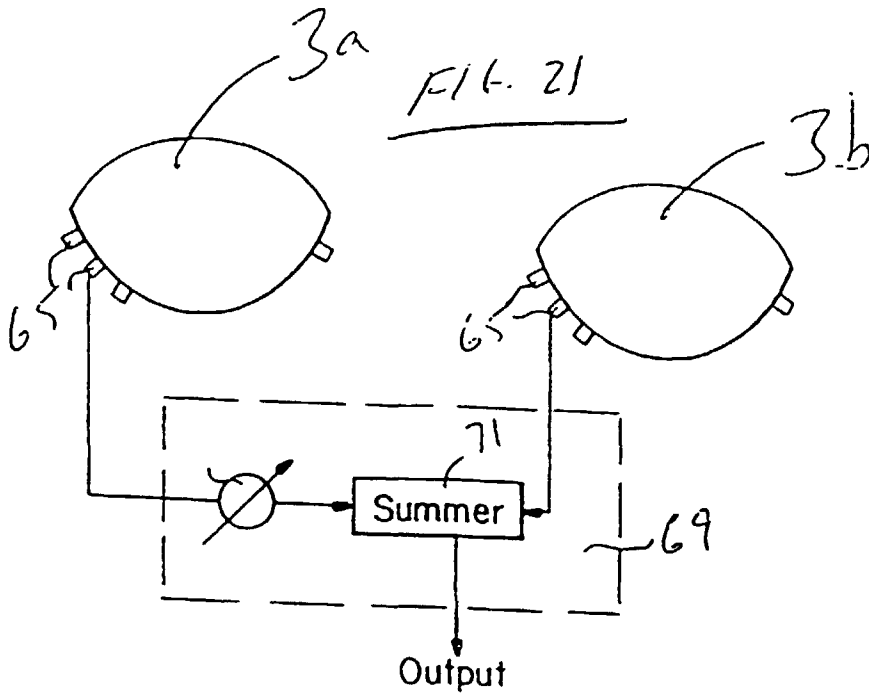

Fig. 17

FIG. 18







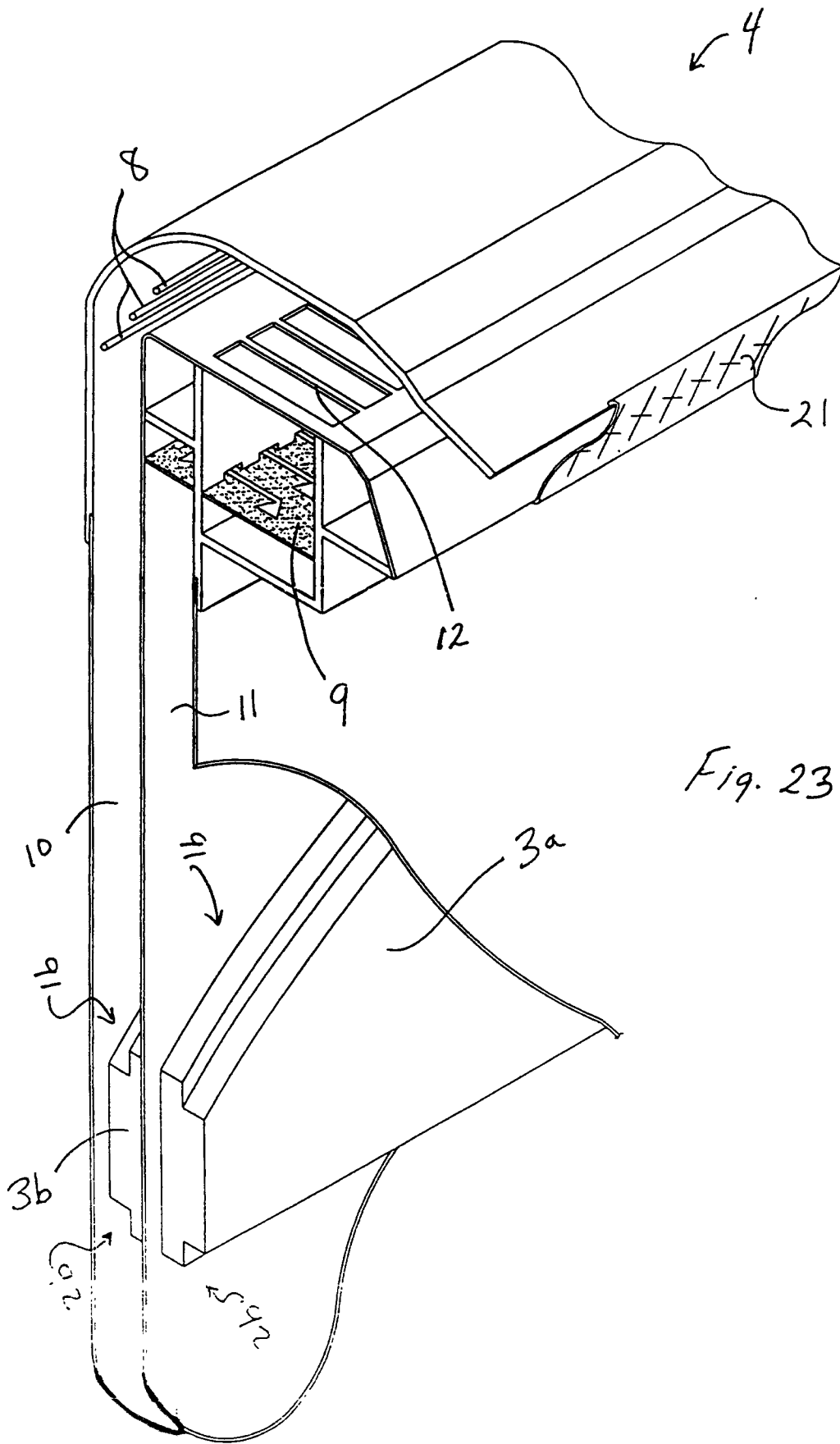

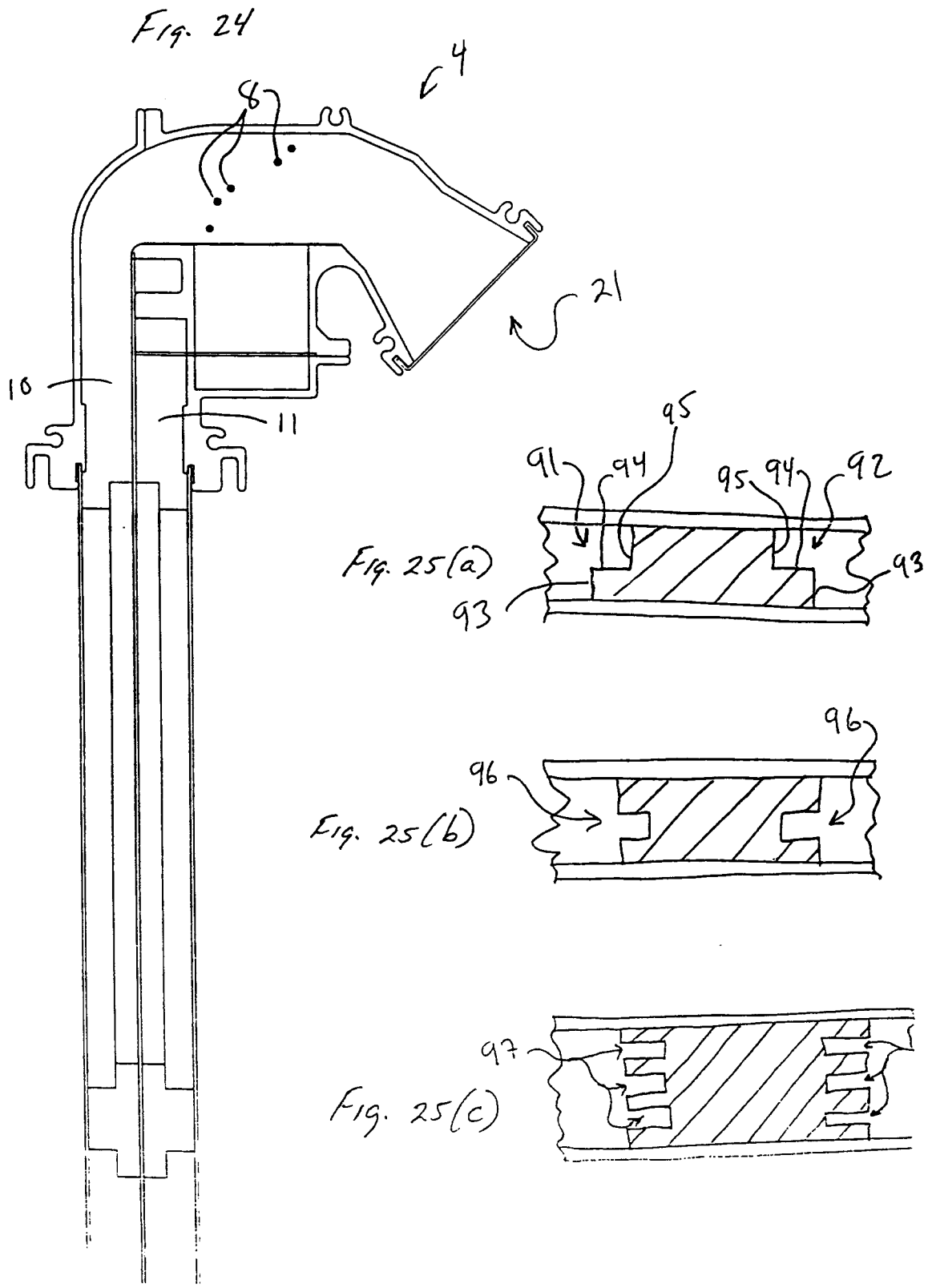

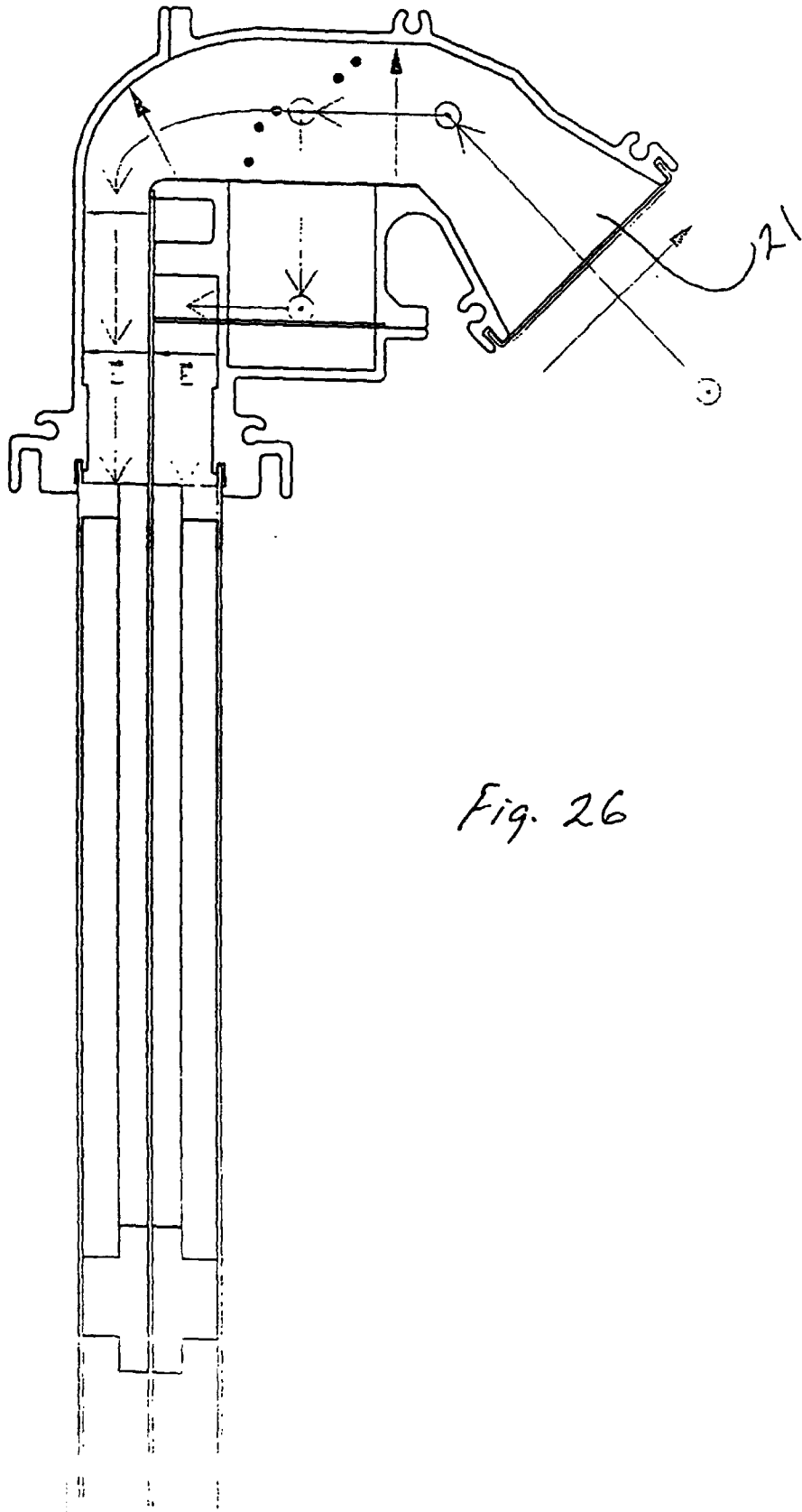
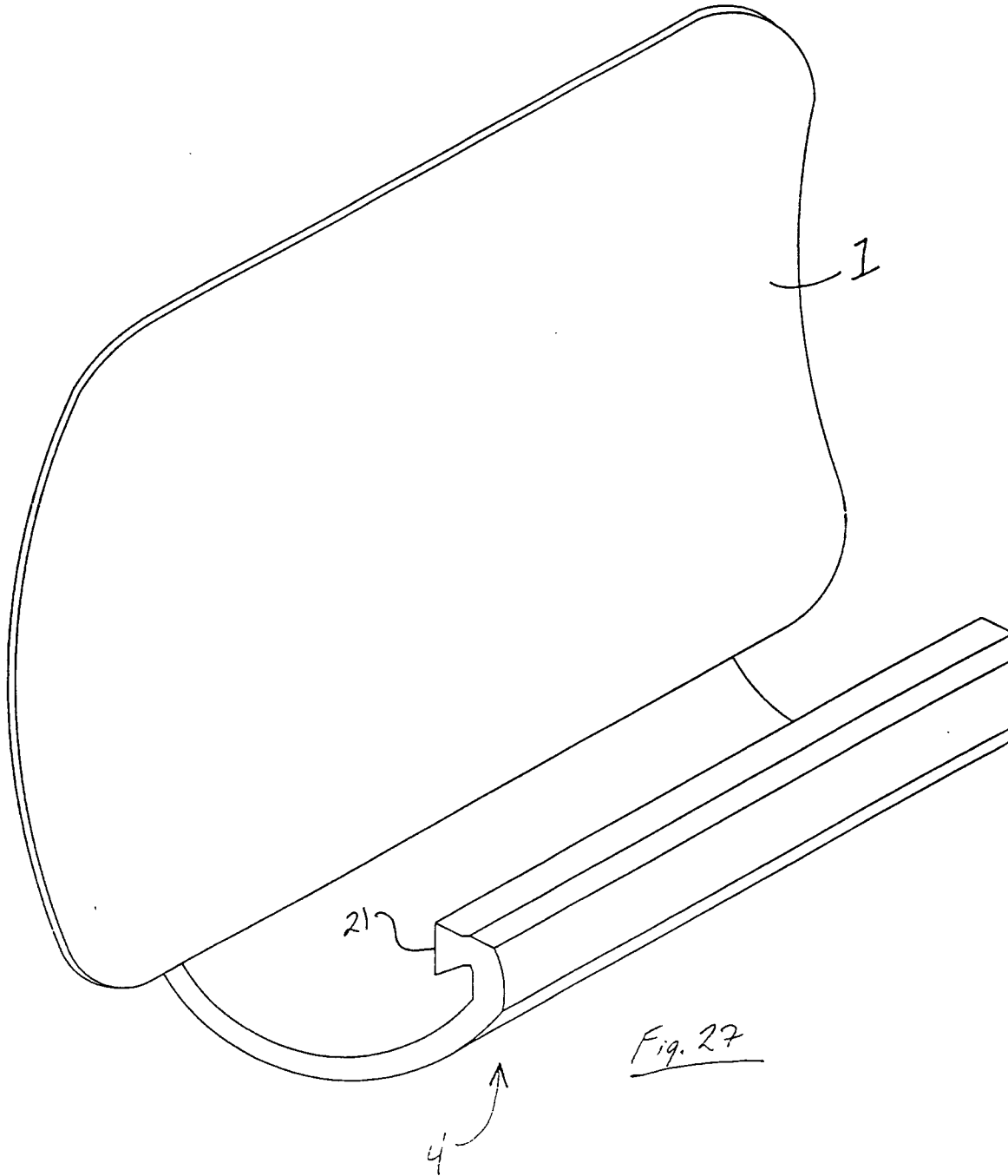

Fig. 26



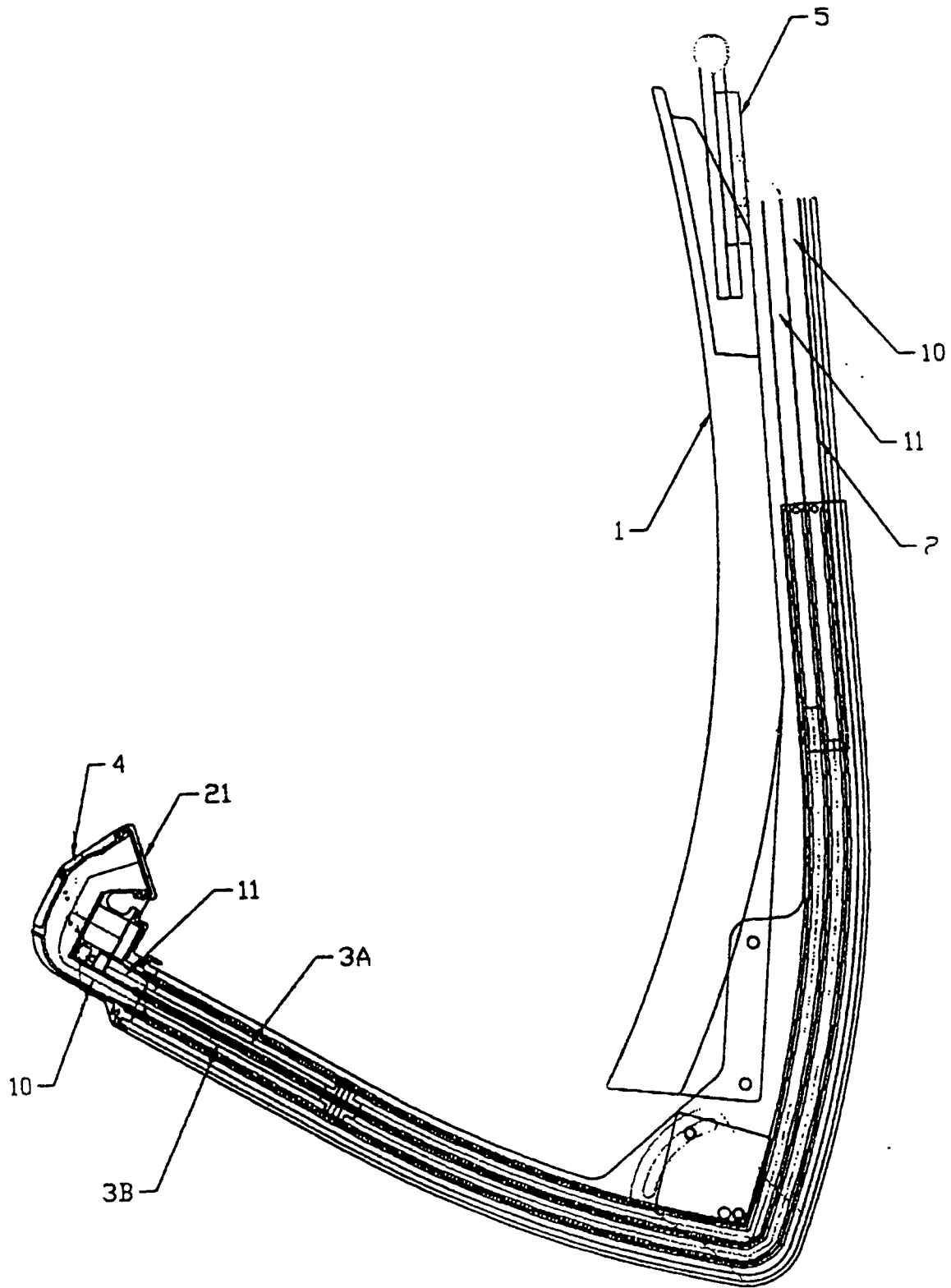

FIG. 28