



US00D621261S

(12) **United States Design Patent**  
**DeMarco**

(10) **Patent No.:** **US D621,261 S**

(45) **Date of Patent:** **\*\* Aug. 10, 2010**

(54) **CONTAINER**

(75) Inventor: **Jenny DeMarco**, Addison, TX (US)

(73) Assignee: **Mary Kay Inc.**, Dallas, TX (US)

(\*\*) Term: **14 Years**

(21) Appl. No.: **29/334,325**

(22) Filed: **Mar. 24, 2009**

**Related U.S. Application Data**

(63) Continuation of application No. 29/306,116, filed on Apr. 2, 2008, now Pat. No. Des. 588,916.

(51) **LOC (9) Cl.** ..... **09-01**

(52) **U.S. Cl.** ..... **D9/504**

(58) **Field of Classification Search** ..... D9/50,  
D9/502-505, 516, 549, 558, 682, 686, 688-692,  
D9/537, 539, 545; D28/76, 78, 82; D7/509,  
D7/602; 215/379, 381-382; 220/660, 662,  
220/669, 675

See application file for complete search history.

(56) **References Cited**

**U.S. PATENT DOCUMENTS**

D51,066 S	7/1917	Hoffman	.....	D9/772
1,443,564 A	1/1923	Dolan	.....	229/5.5
1,491,783 A	4/1924	Bartold	.....	229/5.6
1,532,830 A	4/1925	Marceau	.....	132/307
1,551,006 A	8/1925	Bruns	.....	220/996
1,582,631 A	4/1926	Bruns	.....	220/23.87
1,717,464 A	6/1929	Neely	.....	206/527
D96,604 S	8/1935	Hankar	.....	D9/504
2,012,942 A	9/1935	Acker	.....	229/125.05
2,036,928 A	7/1936	Dreux et al.	.....	229/123.2
2,057,293 A	10/1936	Dreux et al.	.....	493/108
2,076,549 A	4/1937	Conner	.....	215/6
2,211,885 A	8/1940	Dreux et al.	.....	229/125.19
D127,331 S *	5/1941	Rosenfeld	.....	D9/503
D128,850 S	8/1941	Petzold	.....	D25/88
2,307,648 A	1/1943	Tremolieres	.....	206/525
2,315,635 A	4/1943	McCarthy et al.	.....	493/86
2,446,080 A	7/1948	Dennis	.....	132/293

D153,938 S	5/1949	Graham	.....	D28/77
2,797,839 A	7/1957	Root	.....	220/23.87
2,808,090 A	10/1957	Casalino	.....	220/62.18
D188,138 S	6/1960	Bindman	.....	D9/552
3,023,886 A	6/1962	Abrams	.....	401/183
D196,393 S	9/1963	Sanders et al.	.....	D9/448
3,156,279 A	11/1964	Grebowiec et al.	.....	215/12.1
3,206,016 A	9/1965	Fowler et al.	.....	206/403
3,244,313 A	4/1966	De Wayne Miles	.....	220/288

(Continued)

**OTHER PUBLICATIONS**

U.S. Appl. No. 29/306,117, filed Apr. 2, 2008, DeMarco.

*Primary Examiner*—Ian Simmons

*Assistant Examiner*—Dana L Sipos

(74) *Attorney, Agent, or Firm*—Fulbright & Jaworski L.L.P.

(57) **CLAIM**

The ornamental design for a container, as shown and described.

**DESCRIPTION**

FIG. 1 is a top perspective view of a container showing our new design;

FIG. 2 is a side elevation view thereof, the opposing side being identical;

FIG. 3 is a top plan view thereof;

FIG. 4 is a bottom plan view thereof;

FIG. 5 is an exploded top perspective view thereof; and,

FIG. 6 is an exploded side elevation view thereof, the opposing side being identical.

The broken lines in the drawings showing the container insert illustrate the portions of the design that form no part of the claim.

**1 Claim, 4 Drawing Sheets**

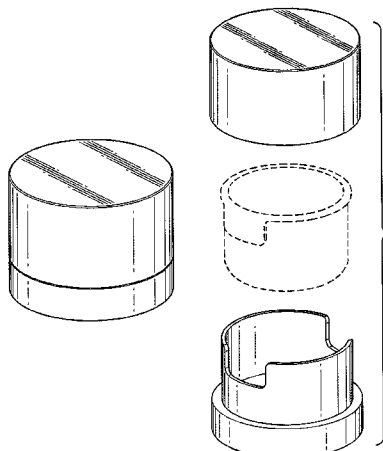

# US D621,261 S

Page 2

## U.S. PATENT DOCUMENTS

3,254,803 A	6/1966	Meshberg .....	222/182	D388,549 S	12/1997	Mouyiaris .....	D28/82
3,311,248 A	3/1967	Marchant .....	215/13.1	D389,060 S	1/1998	De Laforcade .....	D9/448
D216,552 S	2/1970	Curry et al. ....	D7/629	5,704,378 A	1/1998	Machelett .....	132/304
D217,438 S	5/1970	Barbach et al. ....	D9/154	D391,159 S	2/1998	Sheffler .....	D9/500
3,514,017 A	5/1970	Malone .....	222/321.7	5,772,083 A	6/1998	Joulia .....	222/396
3,520,452 A	7/1970	Malone .....	222/321.1	D396,329 S	7/1998	Litton .....	D28/82
3,534,890 A	10/1970	Iannacone .....	222/402.14	D398,079 S	9/1998	Denison .....	D28/82
3,550,803 A	12/1970	Pelli .....	215/12.1	D400,783 S	11/1998	De Mourgues .....	D9/691
3,620,399 A	11/1971	Rapeaud .....	215/13	D403,470 S	* 12/1998	Litton et al. ....	D28/82
D223,691 S	5/1972	Newman .....	D28/77	5,842,604 A	12/1998	Stahley et al. ....	222/95
D227,003 S	5/1973	Graham .....	D9/141	D403,589 S	1/1999	Wong .....	D9/529
D232,916 S	9/1974	Bettonica .....	D9/164	D404,295 S	1/1999	Bertolini et al. ....	D9/691
4,162,010 A	* 7/1979	Hovsepian .....	206/229	5,871,700 A	2/1999	Konrad .....	422/102
4,311,255 A	1/1982	Meshberg .....	222/183	D408,285 S	4/1999	Favre .....	D9/503
4,369,799 A	1/1983	Napoleon .....	132/294	D409,086 S	5/1999	Brown et al. ....	D9/428
4,370,989 A	2/1983	Taylor .....	132/317	D411,100 S	6/1999	Torres .....	D9/692
D272,006 S	12/1983	Geiger .....	D28/5	D411,742 S	6/1999	Kokenge et al. ....	D9/434
4,421,127 A	12/1983	Geer .....	132/294	D411,747 S	6/1999	Kokenge et al. ....	D9/503
D272,804 S	2/1984	Braun .....	D9/353	D413,257 S	8/1999	Favre .....	D9/690
4,429,798 A	2/1984	Borows .....	215/12.1	5,938,016 A	8/1999	Erdtmann .....	206/221
D274,848 S	7/1984	Chevassus .....	D28/76	D413,793 S	9/1999	Favre .....	D9/692
D275,733 S	10/1984	Pardo .....	D9/352	D416,800 S	11/1999	Herrmann .....	D9/500
4,526,302 A	7/1985	Brunet .....	222/321.7	5,975,093 A	11/1999	Joulia .....	132/293
D280,975 S	10/1985	Van Dine .....	D9/353	6,009,885 A	1/2000	Nam .....	132/293
D281,054 S	10/1985	Mendrad .....	D9/688	D420,466 S	2/2000	Coates et al. ....	D28/76
D281,764 S	12/1985	Legrottaglie .....	D9/504	D420,766 S	2/2000	Coates et al. ....	D28/76
D282,630 S	2/1986	Braun .....	D9/504	6,021,784 A	2/2000	Yuhara .....	132/293
D287,824 S	1/1987	Rayner .....	D9/780	6,021,924 A	2/2000	Suck et al. ....	222/105
4,676,408 A	6/1987	Speitel .....	222/183	D422,902 S	4/2000	Kikuchi .....	D9/689
4,826,014 A	5/1989	Schefer .....	206/581	6,047,710 A	4/2000	Irving et al. ....	132/293
D303,584 S	9/1989	Bakic .....	D28/91	6,053,363 A	4/2000	Revenu .....	222/82
4,863,034 A	9/1989	Contreras, Sr. ....	206/581	D423,922 S	5/2000	Ochi et al. ....	D9/688
D306,826 S	3/1990	Bormioli .....	D9/504	D424,749 S	5/2000	Zalzal .....	D28/76
4,944,430 A	7/1990	Graf et al. ....	222/259	D424,750 S	5/2000	Zalzal .....	D28/76
4,982,751 A	1/1991	Oishi et al. ....	132/299	6,055,992 A	5/2000	Skarne .....	132/293
5,005,697 A	4/1991	Jimbo et al. ....	206/235	D426,160 S	6/2000	Lindsay et al. ....	D9/500
D322,391 S	12/1991	Morane .....	D9/688	D426,466 S	6/2000	Nervins et al. ....	D9/529
D322,392 S	12/1991	Schneider et al. ....	D9/689	D426,768 S	6/2000	Gattineri .....	D9/690
D322,750 S	12/1991	Sommer .....	D9/688	6,076,679 A	6/2000	Yuhara et al. ....	206/581
D324,171 S	2/1992	Morane .....	D9/688	6,085,927 A	7/2000	Kusz .....	220/23.87
5,099,998 A	3/1992	Curzon et al. ....	206/514	H1855 H	8/2000	Litton et al. ....	D28/82
5,123,571 A	6/1992	Rebeyrolle et al. ....	222/105	D432,017 S	10/2000	Alvarado .....	D9/529
5,161,556 A	11/1992	Audebourg et al. ....	132/296	D432,720 S	10/2000	Finocchiaro et al. ....	D28/76
5,165,603 A	* 11/1992	Hahn .....	239/55	D432,722 S	10/2000	Wardlaw .....	D28/76
D334,705 S	4/1993	Pereira et al. ....	D9/689	D433,190 S	10/2000	Finocchiaro et al. ....	D28/76
D335,086 S	4/1993	Wacker .....	D9/529	6,129,089 A	10/2000	Yuhara .....	132/300
5,199,451 A	4/1993	Montoli .....	132/315	6,138,686 A	10/2000	Yuhara .....	132/294
D344,017 S	2/1994	Lang et al. ....	D9/727	D434,221 S	11/2000	Chao .....	D3/265
D346,328 S	4/1994	Labrie .....	D9/778	D434,324 S	11/2000	Gobe .....	D9/504
D347,571 S	6/1994	Wacker .....	D9/688	6,149,008 A	11/2000	Yuhara .....	206/581
5,323,924 A	6/1994	Wolff .....	220/23.87	D434,667 S	12/2000	Gobe .....	D9/529
5,328,055 A	7/1994	Battle .....	222/83.5	D435,449 S	12/2000	Moretti .....	D9/500
D350,837 S	9/1994	Kirby .....	D28/82	D435,450 S	12/2000	Eisenbarth .....	D9/500
5,358,147 A	10/1994	Adams et al. ....	222/183	D436,233 S	1/2001	Failliant-Dumas .....	D28/91
D352,896 S	11/1994	Jones .....	D9/428	D436,532 S	1/2001	Richardson .....	D9/428
5,373,862 A	12/1994	Blachut .....	132/294	D437,212 S	2/2001	Adachi et al. ....	D9/686
5,431,177 A	7/1995	Kecman .....	132/303	D438,785 S	3/2001	Baron .....	D9/689
D364,669 S	11/1995	Winner .....	D22/117	D440,150 S	4/2001	Tsai .....	D9/689
D365,020 S	12/1995	Dinand .....	D9/689	D443,821 S	6/2001	Bakic .....	D9/500
D367,423 S	2/1996	Stanley .....	D9/424	6,264,054 B1	7/2001	Miyake et al. ....	220/23.83
D367,996 S	3/1996	Rausch .....	D7/602	D446,456 S	8/2001	Adachi et al. ....	D9/529
5,503,302 A	4/1996	DeJonge .....	222/82	D447,290 S	8/2001	Huai .....	D30/129
5,516,006 A	5/1996	Meshberg .....	222/25	6,302,607 B1	10/2001	Burrows et al. ....	401/18
5,526,960 A	6/1996	Breidenbach et al. ....	222/183	6,311,701 B1	11/2001	Yuhara et al. ....	132/294
5,549,200 A	8/1996	Cowan et al. ....	206/362	6,334,449 B1	1/2002	Burrows et al. ....	132/114
5,553,748 A	9/1996	Battle .....	222/94	6,354,452 B1	3/2002	DeSalvo et al. ....	220/23.87
5,586,694 A	12/1996	Breidenbach et al. ....	222/183	6,401,955 B1	6/2002	Yang .....	220/23.87
5,605,167 A	2/1997	Montoli .....	132/294	D460,692 S	7/2002	Cumberbatch .....	D9/500
5,664,700 A	9/1997	Battle .....	222/105	6,505,986 B1	1/2003	Older .....	401/183
D385,793 S	11/1997	Marsal .....	D9/203	D469,684 S	2/2003	Lerolle .....	D9/682
D388,320 S	12/1997	Lamb .....	D9/688	D470,273 S	2/2003	Revivo .....	D28/76
				D472,152 S	3/2003	Joubert .....	D9/529
				D474,405 S	5/2003	Togasawa .....	D9/504

# US D621,261 S

D474,974 S	5/2003	Bakic .....	D9/504	D516,923 S	3/2006	Moore .....	D9/682
D474,978 S	5/2003	Varlet .....	D9/549	D518,381 S	4/2006	Egawa .....	D9/504
D476,233 S	6/2003	Versace .....	D9/504	D519,027 S	4/2006	Haber et al. ....	D9/428
D476,572 S	7/2003	Merritt .....	D9/504	D521,383 S	5/2006	Priestman .....	D9/529
D477,216 S	7/2003	Gronwall .....	D9/727	D521,386 S	5/2006	Priestman .....	D9/529
D477,225 S	7/2003	Pinnarvaia .....	D9/454	D522,695 S	6/2006	Desdoigts .....	D28/82
6,588,960 B1	7/2003	Barwin et al. ....	401/125	D523,752 S	6/2006	Bried et al. ....	D9/524
6,622,890 B2	9/2003	Gueret .....	222/1	D524,161 S	7/2006	Sauer .....	D9/529
D480,307 S	10/2003	Canamasas Puigbo .....	D9/504	D525,136 S	7/2006	Bakic .....	D9/522
6,648,538 B2	11/2003	Gueret .....	401/130	D526,205 S	8/2006	Priestman .....	D9/529
6,651,835 B2	11/2003	Iskra .....	220/23.87	D527,642 S	9/2006	Priestman .....	D9/529
D483,527 S	12/2003	Ashiwa et al. ....	D28/91	D530,208 S	10/2006	Danne et al. ....	D9/504
D484,644 S	12/2003	Noh .....	D28/76	D530,622 S	10/2006	Geiberger .....	D9/688
D485,016 S	1/2004	Noh .....	D28/76	D531,036 S	10/2006	Bried et al. ....	D9/504
D485,017 S	1/2004	Noh .....	D28/76	D531,041 S	10/2006	Sauer et al. ....	D9/529
6,749,078 B2	6/2004	Iskra .....	220/23.87	7,134,577 B1	11/2006	Verma .....	222/321.9
D493,721 S	8/2004	Puigbo .....	D9/504	D538,482 S *	3/2007	Martinez .....	D28/89
D494,474 S	8/2004	Houk et al. ....	D9/504	D541,176 S	4/2007	Bried .....	D9/780
D497,809 S	11/2004	Fenton et al. ....	D9/500	D542,149 S	5/2007	Boucher .....	D9/686
D498,678 S	11/2004	Ames .....	D9/529	D543,458 S	5/2007	Dittmer .....	D9/504
D499,338 S	12/2004	Mulder et al. ....	D9/500	7,246,724 B2	7/2007	Dave .....	222/325
6,832,702 B2	12/2004	Garcia .....	222/183	7,249,720 B2	7/2007	Mathiez .....	239/302
D502,649 S	3/2005	Martinez .....	D9/529	D560,495 S	1/2008	Mettler et al. ....	D9/504
D503,086 S	3/2005	Tsai .....	D9/685	7,314,051 B2	1/2008	Yuhara et al. ....	132/294
6,871,798 B2	3/2005	Mathiez .....	239/302	7,314,052 B2	1/2008	Yuhara et al. ....	132/294
D504,542 S	4/2005	Noh .....	D28/76	7,322,478 B2	1/2008	Goto et al. ....	206/581
D505,074 S	5/2005	Bakic .....	D9/504	7,451,877 B2	11/2008	Koga et al. ....	206/581
D506,128 S *	6/2005	Foi .....	D9/715	D588,916 S *	3/2009	DeMarco .....	D9/504
6,910,597 B2	6/2005	Iskra .....	220/23.87	2002/0036155 A1	3/2002	Freeman et al. ....	206/581
6,923,347 B2	8/2005	Winckels .....	222/206	2003/0071040 A1	4/2003	Brodner et al. ....	220/23.87
D509,434 S	9/2005	Haruta .....	D9/504	2003/0080128 A1	5/2003	Brodner et al. ....	220/23.87
D509,739 S	9/2005	Haruta .....	D9/504	2005/0178694 A1	8/2005	Mecca et al. ....	206/581
6,945,403 B2	9/2005	Lombardi .....	206/581	2005/0184090 A1	8/2005	DeJonge .....	222/129
6,945,419 B2	9/2005	Bertazza et al. ....	220/23.87	2005/0194384 A1	9/2005	Petit .....	220/230
D510,524 S	10/2005	Houk et al. ....	D9/503	2005/0218033 A1	10/2005	Curtis .....	206/581
D512,636 S	12/2005	Pace .....	D9/504	2005/0284891 A1	12/2005	Ramet et al. ....	222/321.7
D513,386 S	1/2006	Pace et al. ....	D9/504	2006/0027481 A1	2/2006	Gelardi et al. ....	206/581
6,983,864 B1	1/2006	Cagle .....	222/131	2006/0043109 A1	3/2006	Masudea .....	222/105
D514,936 S	2/2006	Pace et al. ....	D9/504	2006/0118454 A1	6/2006	Kang .....	206/581
D515,426 S	2/2006	Pace et al. ....	D9/504	2006/0186019 A1	8/2006	Lu .....	206/581
D515,439 S	2/2006	Pace .....	D9/746	2007/0020032 A1	1/2007	Abbas .....	401/188 A
D515,516 S	2/2006	Mayo et al. ....	D13/171				
D515,928 S	2/2006	Pace .....	D9/504				

\* cited by examiner

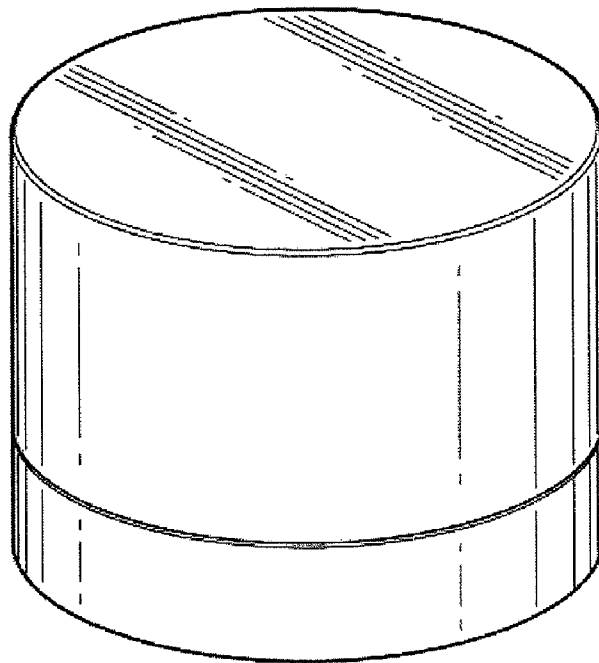

*FIG. 1*

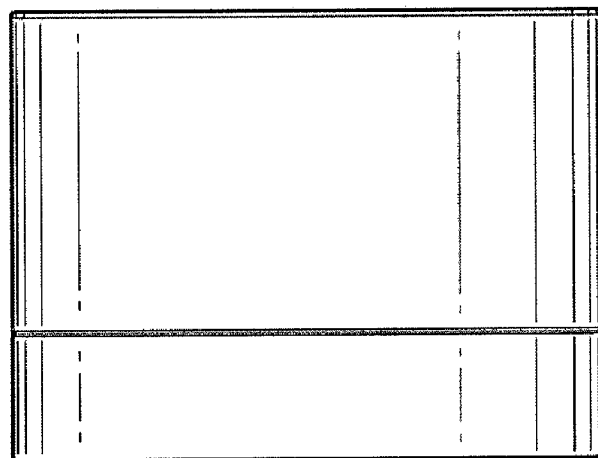

*FIG. 2*

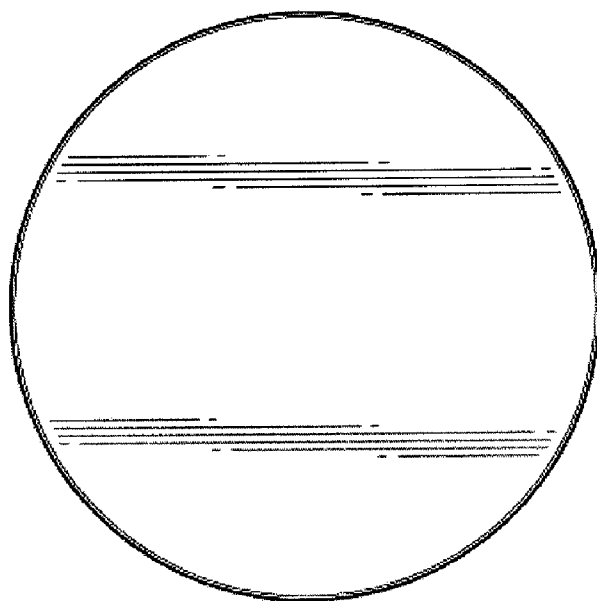

*FIG. 3*

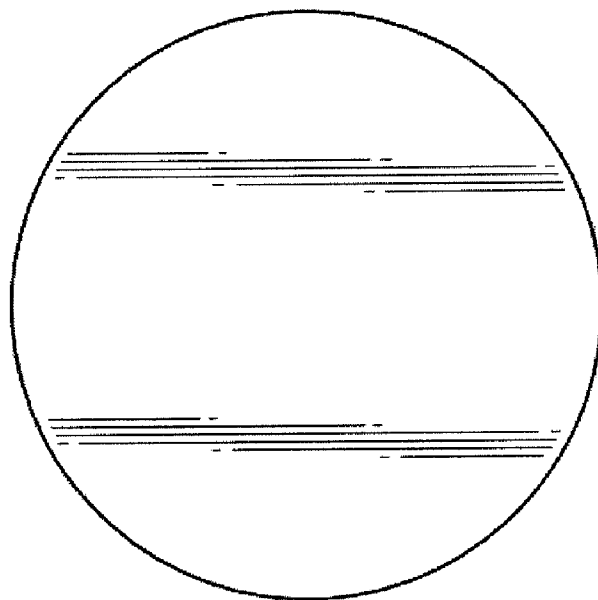

*FIG. 4*

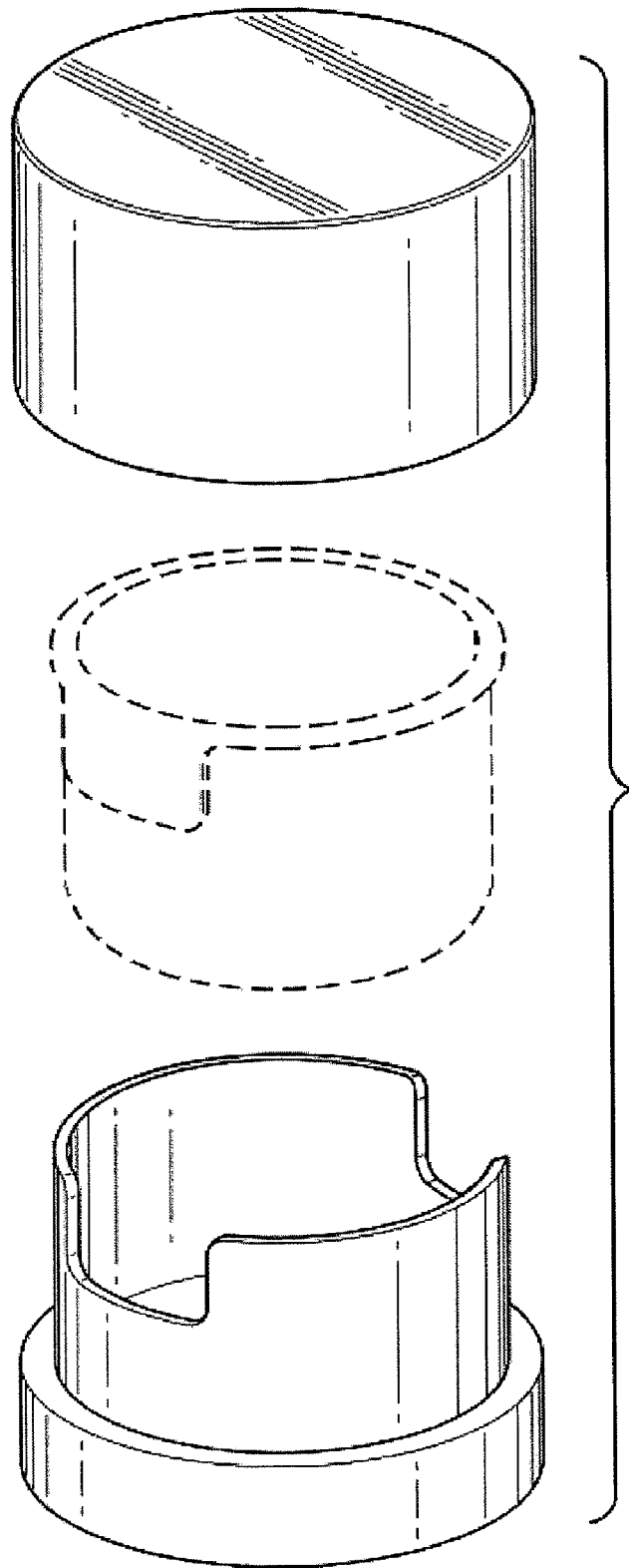

FIG. 5

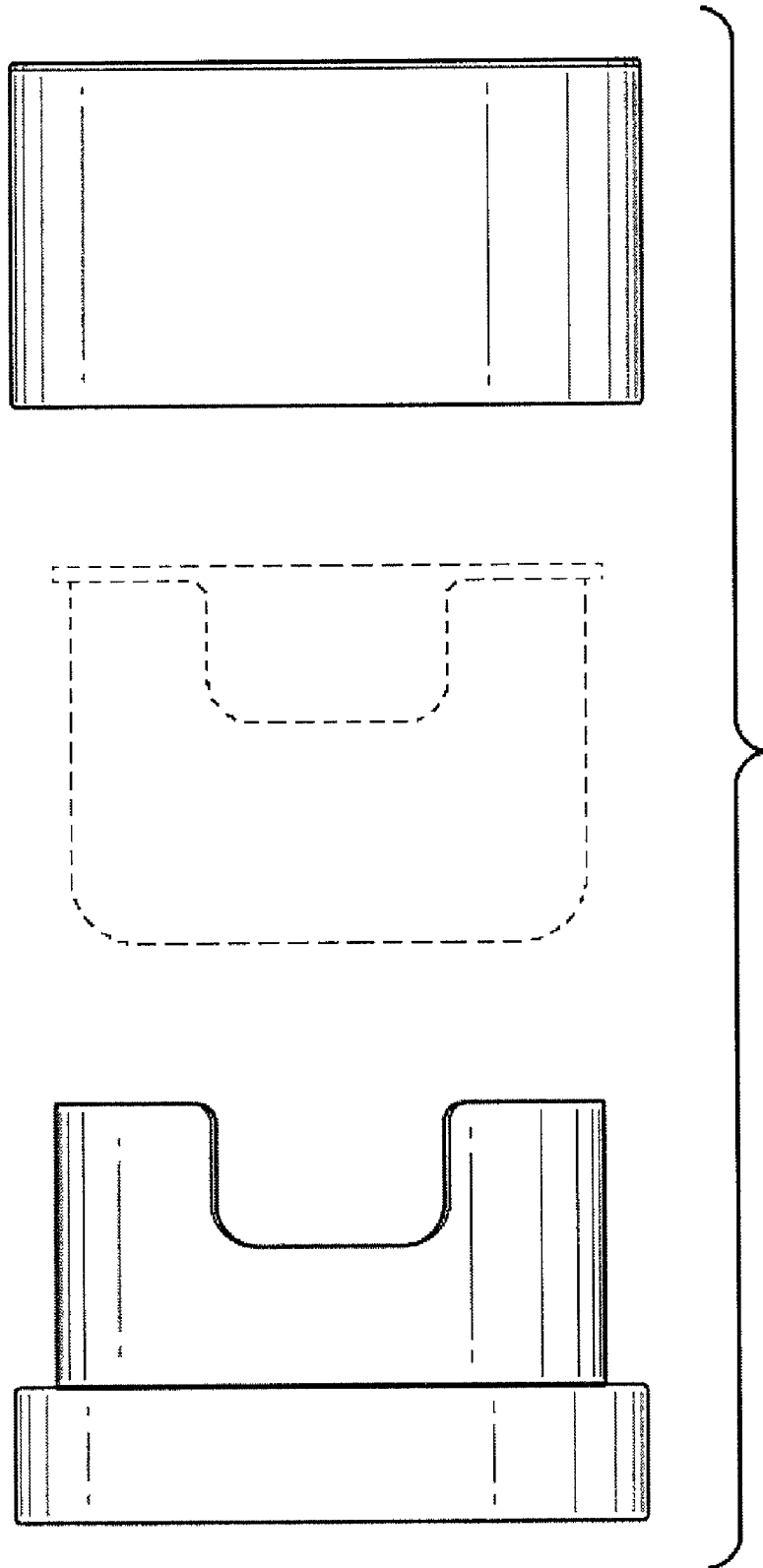

FIG. 6