



US00RE47132E

(19) **United States**
(12) **Reissued Patent**
Gosling et al.

(10) **Patent Number:** **US RE47,132 E**
(45) **Date of Reissued Patent:** ***Nov. 20, 2018**

(54) **INTEGRATED RECONFIGURABLE WALL SYSTEM**

(58) **Field of Classification Search**
USPC 52/239, 238.1, 479, 481.1, 481.2
See application file for complete search history.

(71) Applicant: **DIRTT Environmental Solutions, Ltd.**, Calgary (CA)

(56) **References Cited**

(72) Inventors: **Geoff Gosling**, Calgary (CA); **Mogens Smed**, DeWinton (CA)

U.S. PATENT DOCUMENTS

(73) Assignee: **DIRTT ENVIRONMENTAL SOLUTIONS, LTD**, Calgary (CA)

2,042,290 A 5/1936 Barrett
2,658,810 A 11/1953 Ellis
(Continued)

(*) Notice: This patent is subject to a terminal disclaimer.

FOREIGN PATENT DOCUMENTS

(21) Appl. No.: **14/305,819**

CA 55086 10/1985
CA 1294107 11/1987
(Continued)

(22) Filed: **Jun. 16, 2014**

OTHER PUBLICATIONS

Related U.S. Patent Documents

European Search Report, EP 12800672, dated Oct. 10, 2014.
(Continued)

Reissue of:

(64) Patent No.: **8,024,901**
Issued: **Sep. 27, 2011**
Appl. No.: **11/205,314**
Filed: **Aug. 17, 2005**

Primary Examiner — Jeffrey L Gellner
(74) *Attorney, Agent, or Firm* — Workman Nydegger

U.S. Applications:

(63) Continuation of application No. 14/032,931, filed on Sep. 20, 2013, which is an application for the reissue of Pat. No. 8,024,901.
(Continued)

(57) **ABSTRACT**

A movable reconfigurable wall system having at least one module having a front and rear surface, the at least one module having: vertical end frames disposed at least at its side edges, each the vertical end frame having a vertically extending flange directed toward the front surface and a vertically extending flange directed toward the rear surface; a plurality of horizontal stringers affixed between the pair of vertical end frames; and an aesthetic surface affixed to the stringers; and a removable connecting strip, the connecting strip adapted to affix about one of the two flanges on one of the vertical end frames and join the one of the two flanges to a corresponding flange on one of a second module, a wall bracket, a finishing trim or a connection post.

(51) **Int. Cl.**
E04H 1/00 (2006.01)
E04B 1/00 (2006.01)
E04B 2/74 (2006.01)

(52) **U.S. Cl.**
CPC **E04B 2/7424** (2013.01); **E04B 2002/742** (2013.01); **E04B 2002/749** (2013.01);
(Continued)

35 Claims, 22 Drawing Sheets

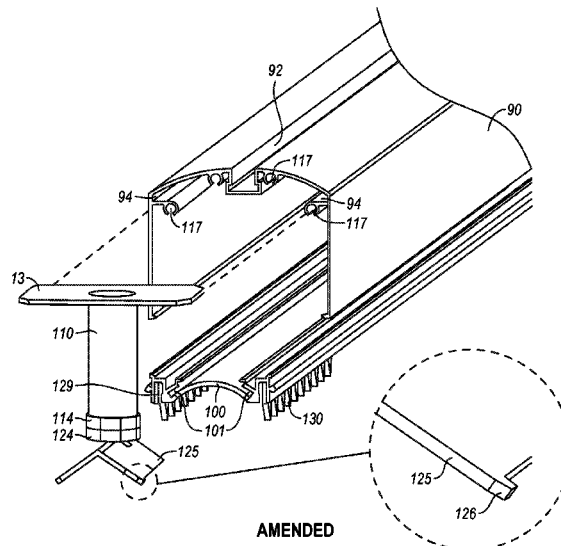
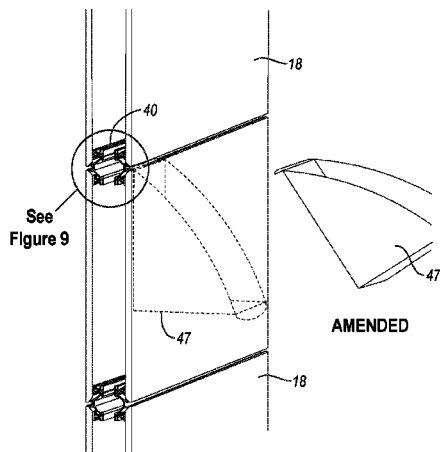

US RE47,132 E

Related U.S. Application Data

- (60) Provisional application No. 60/601,985, filed on Aug. 17, 2004.
- (52) **U.S. Cl.**
CPC E04B 2002/7462 (2013.01); E04B 2002/7483 (2013.01)

References Cited

U.S. PATENT DOCUMENTS

- 2,676,481 A 4/1954 Hoffman
- 3,037,593 A 6/1962 Webster
- 3,088,127 A 5/1963 Charles
- 3,180,457 A 4/1965 Bohnsack
- 3,521,937 A 7/1970 Buhmaster
- 3,602,226 A 9/1971 Ericson
- 3,621,635 A 11/1971 Lange
- 3,675,382 A * 7/1972 Licklitter E06B 1/18 52/204.595
- 3,696,569 A 10/1972 Didry
- 3,885,361 A 5/1975 De Schutter
- 4,027,878 A 6/1977 Dadbeh
- 4,103,373 A 8/1978 Luedtke
- 4,128,983 A 12/1978 Matsubara
- 4,277,920 A 7/1981 Dixon
- 4,438,614 A 3/1984 Raith
- 4,449,337 A 5/1984 Gzym
- 4,493,172 A 1/1985 Jones
- 4,535,577 A 8/1985 Tenser
- 4,631,881 A 12/1986 Charman
- 4,688,491 A 8/1987 Herrera
- 4,752,101 A 6/1988 Yurchenco
- 4,757,657 A 7/1988 Mitchell
- D302,497 S 8/1989 Zapf
- D309,381 S 7/1990 Buhk
- D309,382 S 7/1990 Randall
- D309,384 S 7/1990 Buhk
- D309,385 S 7/1990 Buhk
- D309,386 S 7/1990 Buhk
- 4,991,365 A 2/1991 Jackson
- 5,038,539 A 8/1991 Kelley
- 5,056,285 A 10/1991 Frascaroli
- D321,801 S 11/1991 Friedman
- 5,064,247 A 11/1991 Clark
- D323,251 S 1/1992 Zapf
- 5,086,597 A 2/1992 Kelley
- D325,309 S 4/1992 Worrell
- 5,117,599 A 6/1992 Voss
- D327,794 S 7/1992 Zapf
- D328,680 S 8/1992 Zapf
- 5,144,777 A 9/1992 Fishel
- D330,295 S 10/1992 Zapf
- 5,155,955 A 10/1992 Ball
- D330,641 S 11/1992 Zapf
- D330,643 S 11/1992 Zapf
- 5,159,793 A 11/1992 Deugo
- D331,335 S 12/1992 Zapf
- D331,513 S 12/1992 Zapf
- 5,171,060 A 12/1992 Kaye
- 5,172,530 A 12/1992 Fishel
- 5,184,441 A 2/1993 Balfanz
- 5,204,149 A 4/1993 Phenicie
- 5,207,037 A 5/1993 Giles
- 5,218,799 A 6/1993 Appino
- D337,003 S 7/1993 Rowland
- 5,227,005 A 7/1993 Zodrow et al.
- 5,321,579 A 6/1994 Brown
- D348,786 S 7/1994 Tolleson
- 5,351,452 A 10/1994 Gates
- 5,352,033 A 10/1994 Gresham
- 5,394,668 A 3/1995 Lim
- 5,488,808 A 2/1996 Cahill
- D371,683 S 7/1996 Tolleson
- 5,544,593 A 8/1996 Canfield
- 5,592,794 A 1/1997 Tundaun

- 5,600,926 A * 2/1997 Ehrlich 52/239
- 5,601,348 A 2/1997 Minkovski
- 5,642,593 A 7/1997 Shieh
- 5,669,314 A 9/1997 Grant
- 5,740,644 A 4/1998 Menchetti
- 5,740,650 A 4/1998 Seiber
- 5,740,744 A 4/1998 Nashirozawa
- 5,746,035 A 5/1998 Seiber
- 5,792,541 A 8/1998 Herrera
- D397,880 S 9/1998 Saul
- D398,464 S 9/1998 Cronk
- 5,802,789 A 9/1998 Goodman
- 5,813,178 A 9/1998 Edwards
- 5,822,935 A 10/1998 Mitchell
- 5,826,385 A 10/1998 Dykstra
- 5,836,121 A 11/1998 Hofman
- 5,839,240 A 11/1998 Eisholz
- 5,852,904 A 12/1998 Yu
- 5,870,867 A 2/1999 Mitchell
- 5,875,596 A 3/1999 Muller
- 5,881,979 A 3/1999 Rozier
- 5,913,787 A 6/1999 Edwards
- 5,931,429 A * 8/1999 Hellwig A47B 5/06 108/108
- 5,950,386 A * 9/1999 Shipman et al. 52/481.2
- 5,978,988 A 11/1999 Burchett
- 6,012,258 A 1/2000 Brown
- 6,047,508 A 4/2000 Goodman
- 6,058,667 A 5/2000 MacDonald
- 6,094,872 A 8/2000 Ward
- 6,112,472 A 9/2000 Van Dyk
- 6,122,871 A 9/2000 Russell
- 6,128,877 A 10/2000 Goodman
- 6,134,845 A 10/2000 Shipman
- 6,141,926 A 11/2000 Rossiter
- 6,158,179 A 12/2000 Ackerly
- 6,161,347 A 12/2000 Yu
- 6,189,270 B1 2/2001 Jeffers
- 6,223,485 B1 5/2001 Beck
- 6,250,020 B1 6/2001 Shipman
- 6,250,032 B1 * 6/2001 Davis et al. 52/239
- 6,260,321 B1 * 7/2001 Rudduck 52/474
- 6,282,854 B1 * 9/2001 Vos et al. 52/239
- 6,295,764 B1 10/2001 Berridge
- 6,301,846 B1 10/2001 Waalkes
- 6,311,441 B1 11/2001 Beavers
- 6,330,773 B1 12/2001 MacDonald
- 6,341,457 B1 * 1/2002 Aerts et al. 52/239
- 6,363,663 B1 * 4/2002 Kane et al. 52/36.6
- 6,393,782 B1 5/2002 Berridge
- 6,393,783 B2 5/2002 Emaus
- 6,397,533 B1 * 6/2002 Hornberger A47B 95/008 52/238.1
- 6,415,567 B1 7/2002 Mead
- 6,446,396 B1 9/2002 Marangoni
- 6,481,168 B1 * 11/2002 Hodges et al. 52/220.7
- 6,484,465 B2 11/2002 Higgins
- 6,490,154 B2 12/2002 Thompson
- 6,497,075 B1 12/2002 Schreiner
- 6,530,181 B1 3/2003 Seiber
- 6,557,310 B2 5/2003 Marshall
- 6,571,855 B1 6/2003 Goldsmith
- 6,581,344 B1 6/2003 Niewiadomski
- 6,591,563 B2 7/2003 King
- 6,612,077 B2 9/2003 Parshad
- 6,619,008 B1 9/2003 Shivak
- 6,658,805 B1 12/2003 Yu
- 6,668,514 B2 12/2003 Skov
- D485,096 S 1/2004 Overthun
- 6,684,929 B2 2/2004 MacDonald
- 6,688,056 B2 2/2004 Von Hoyningen Huene
- 6,701,677 B2 3/2004 Gresham
- 6,711,871 B2 3/2004 Beirise
- 6,729,085 B2 5/2004 Newhouse
- 6,748,710 B2 6/2004 Gresham
- 6,775,953 B2 8/2004 Burken
- 6,799,404 B2 10/2004 Spransy
- 6,807,776 B2 10/2004 Girdwood
- 6,820,388 B2 11/2004 Newhouse

(56)

References Cited

U.S. PATENT DOCUMENTS

6,851,226	B2	2/2005	MacGregor	2002/0129574	A1	9/2002	Newhouse
6,865,853	B2	3/2005	Burken	2002/0144476	A1	10/2002	Mastelli
6,883,277	B2	4/2005	Wiechecki	2002/0157335	A1	10/2002	Vos
6,889,477	B1	5/2005	Kottman	2003/0005514	A1	1/2003	Kunkel
6,920,727	B2*	7/2005	Yu et al. 52/239	2003/0060080	A1	3/2003	Rees
6,928,785	B2	8/2005	Shipman	2003/0089057	A1*	5/2003	Wiechecki et al. 52/238.1
6,941,716	B2	9/2005	Kottman	2003/0154673	A1	8/2003	Macgregor
6,944,993	B1	9/2005	Jilk	2003/0196388	A1	10/2003	Edwards
6,951,085	B2	10/2005	Hodges	2003/0221384	A1	12/2003	Burken et al.
6,964,138	B2	11/2005	Carroll	2004/0010998	A1	1/2004	Turco
6,981,454	B2	1/2006	Burdick	2004/0020137	A1*	2/2004	Batthey et al. 52/36.1
6,990,909	B2	1/2006	Gosling	2004/0035074	A1	2/2004	Stanescu et al.
6,993,875	B2	2/2006	Rudduck	2004/0093805	A1	5/2004	Underwood
7,051,482	B2	5/2006	MacDonald	2004/0177573	A1*	9/2004	Newhouse et al. 52/239
7,150,127	B2	12/2006	Underwood	2005/0005527	A1	1/2005	Metcalf
7,210,270	B1	5/2007	King	2005/0086871	A1	4/2005	MacGregor
7,310,918	B1	12/2007	Reuter	2006/0042141	A1	3/2006	Hansen
7,434,790	B1	10/2008	Hansen	2006/0048457	A1	3/2006	Yang
7,451,577	B2	11/2008	Little	2006/0059806	A1	3/2006	Gosling et al.
7,461,484	B2	12/2008	Batthey	2006/0185276	A1	8/2006	Pai
7,540,115	B2	6/2009	Metcalf	2007/0277449	A1	12/2007	Burns
7,562,504	B2	7/2009	Herbst	2007/0289225	A1	12/2007	Kern
7,603,821	B2	10/2009	Eberlein	2008/0069632	A1	3/2008	Gosling
7,644,552	B2	1/2010	Kuipers	2008/0295426	A1	12/2008	Milligan
7,661,237	B2	2/2010	Jakob-Bamberg	2008/0302054	A1	12/2008	Gosling
7,707,790	B2	5/2010	Williams	2009/0021122	A1	1/2009	Green
7,818,932	B2	10/2010	Eberlein	2009/0241437	A1	10/2009	Steinle
7,827,745	B2	11/2010	Franceschet	2009/0260311	A1	10/2009	Boyer
7,832,154	B2	11/2010	Gosling	2009/0293406	A1	12/2009	Gosling
7,841,142	B2	11/2010	Towersey	2010/0043142	A1	2/2010	Whitford
7,856,777	B2	12/2010	Lamfers	2010/0192511	A1	8/2010	Gosling
7,861,474	B2	1/2011	Houle	2010/0223857	A1	9/2010	Sutton
7,891,148	B2	2/2011	Underwood	2010/0307086	A1	12/2010	Hibbs
7,908,805	B2	3/2011	Metcalf	2011/0197519	A1	8/2011	Henriott
7,913,459	B2	3/2011	Ball	2012/0186164	A1	7/2012	Pensi
7,918,064	B2	4/2011	Singleton	2012/0317899	A1	12/2012	Von Hoyningen Huene
7,922,224	B2	4/2011	Arias	2014/0102021	A1	4/2014	Gosling
7,984,598	B2	7/2011	Gosling	2014/0310873	A1	10/2014	Gosling
8,015,766	B2	9/2011	Gosling	2015/0007516	A1	1/2015	Glick
8,015,767	B2	9/2011	Glick	2015/0354212	A1	12/2015	Von Hoyningen Huene
8,024,901	B2	9/2011	Gosling	2016/0032644	A1	2/2016	Geller
8,033,059	B2	10/2011	Contois	2016/0053485	A1	2/2016	Von Hoyningen Huene
8,033,068	B2	10/2011	Luttmann				
8,046,957	B2	11/2011	Towersey				
8,151,527	B2	4/2012	Gosling				
8,151,533	B2	4/2012	Krieger				
8,176,707	B2	5/2012	Gosling				
8,215,061	B2	7/2012	Gosling				
8,272,180	B2	9/2012	Glick				
8,307,591	B2	11/2012	Steinle				
8,322,102	B2	12/2012	Krieger				
8,393,122	B2	3/2013	Henriott				
8,474,193	B2	7/2013	Sutton				
8,479,026	B2	7/2013	Lakshmanan				
8,534,021	B2	9/2013	Liu				
8,601,749	B2	12/2013	Von Hoyningen Huene				
8,613,168	B2	12/2013	Von Hoyningen Huene				
8,615,936	B2	12/2013	Von Hoyningen Huene				
8,656,648	B2	2/2014	Liegeois				
8,683,745	B2	4/2014	Artwohl				
D710,025	S	7/2014	Johnson				
8,910,435	B2	12/2014	Feldpausch				
D725,638	S	3/2015	Hofman				
8,966,839	B2	3/2015	Rebman				
9,003,731	B2	4/2015	Gosling				
D731,833	S	6/2015	Fifield				
9,084,489	B2	7/2015	Gosling				
9,206,600	B2	12/2015	Von Hoyningen Huene				
9,284,729	B2	3/2016	Von Hoyningen Huene				
2001/0039774	A1	11/2001	Beirise				
2002/0053174	A1	5/2002	Barmark				
2002/0104271	A1	8/2002	Gallant				
2002/0108330	A1*	8/2002	Yu et al. 52/238.1				
2002/0121056	A1	9/2002	Von Hoyningen				
2002/0124514	A1	9/2002	Higgins				
				CA	2011977	10/1990	
				CA	2002674	5/1991	
				CA	2040822	11/1991	
				CA	2162300	5/1997	
				CA	2273631	10/2001	
				CA	2324050	4/2002	
				CA	2348060	11/2002	
				CA	2359165	4/2003	
				CA	2310869	8/2003	
				CA	2476368	1/2006	
				CA	2428593	8/2007	
				CA	2359547	2/2008	
				CA	2591176	12/2008	
				CA	2634407	12/2008	
				CA	2349964	10/2009	
				CA	2840843	12/2013	
				CA	2535213	4/2014	
				CA	2863783	4/2014	
				CH	686795	6/1996	
				CN	202069245	12/2011	
				DE	1659015	11/1971	
				DE	4207753	9/1993	
				DE	69316247	7/1998	
				DE	19960535	6/2001	
				DE	202004017808	1/2005	
				EP	0443202	8/1991	
				EP	0557092	1/1998	
				EP	0963719	12/1999	
				EP	1094167	4/2001	
				FR	1526637	5/1968	
				GB	2221946	2/1990	
				GB	2283071	4/1995	
				GB	2353541	10/2003	
				JP	HO3 17333	1/1991	

FOREIGN PATENT DOCUMENTS

(56)

References Cited

FOREIGN PATENT DOCUMENTS

JP	2003105908	4/2003
JP	2005155223	6/2005
KR	1020000049102	7/2000
KR	1020070077502	7/2007
WO	GB1259347	1/1972
WO	GB1400613	7/1975
WO	EP0302564	2/1989
WO	WO9212074	7/1992
WO	WO9212300	7/1992
WO	WO9315970	8/1993
WO	WO9323629	11/1993
WO	WO9402695	2/1994
WO	WO9633323	10/1996
WO	WO9746770	12/1997
WO	EP0557092	1/1998
WO	WO9807357	2/1998
WO	WO9816699	4/1998
WO	WO9829623	7/1998
WO	WO9837292	8/1998
WO	WO9851876	11/1998
WO	WO9946453	9/1999
WO	WO9946455	9/1999
WO	WO9946458	9/1999
WO	WO9953156	10/1999
WO	WO9958780	11/1999
WO	WO9963177	12/1999
WO	WO0015918	3/2000
WO	WO0075447	12/2000
WO	WO0171241	9/2001
WO	WO0208851	1/2002
WO	WO02052111	4/2002
WO	WO02103129	12/2002
WO	WO03071045	8/2003
WO	WO03104581	12/2003
WO	2006127804	11/2006
WO	2010121788	10/2010
WO	WO2012173930	12/2012
WO	WO2013130871	9/2013
WO	WO2013185141	12/2013
WO	WO2013188211	12/2013
WO	WO2013188235	12/2013
WO	2014039278	3/2014
WO	WO2014055883	4/2014

OTHER PUBLICATIONS

International Search Report and Written Opinion for PCT/US2012/041906 dated Jan. 31, 2013.
 International Search Report and Written Opinion for PCT/US2012/042314 dated Jun. 13, 2012.
 European Search Report for PCT/US2012/042314 dated Jan. 29, 2015.
 Petition for Inter Partes Review of U.S. Pat. No. 8,024,901, IPR2015-01690, filed Aug. 7, 2015.

Petition for Inter Partes Review of U.S. Pat. No. 8,024,901, IPR2015-01691, filed Aug. 7, 2015.

Genius Architectural Walls, [Publication Date Unlisted], Copyright Date 2004 by KI, Document Code KI-00473/HC/TT/PP/504.

KI Improves STC Rating on its Genius Architectural Wall and receives ICC approval, [Publication Date Unlisted], Dated Feb. 26, 2004.

Lifespace Environmental Wall Systems, [Publication Date Unlisted], Dated Apr. 1995.

Press Release—"KI unveils Genius Full Height Movable Wall Microsite with new interactive features", Accessed on Aug. 14, 2015 at http://web.archive.org/web/20040506230219/http://www.ki.com/about_press_release.asp?id=49.

Office Insight, [Publication Date Unlisted], Dated Mar. 23, 2009.

KI Genius Full-Height Moveable Walls, [Publication Date Unlisted], Copyright Date 2003 by KI, Document Code KI-00506/HC/PP/803. U.S. Specifier Guide and Price Book, [Publication Date Unlisted], Dated Jan. 1998.

Achieving the Atkins Aesthetic: KI's new ThinLine option for its award-winning Genius Architectural Wall flaunts a slimmer figure, [Publication Date Unlisted], Dated Jun. 14, 2004.

SMED International—Lifespace—Technical Information, [Publication Date Unlisted], Dated Jan. 1, 1996.

Teknionaltos—Price and Product Guide Update, [Publication Date Unlisted], Dated Feb. 2002.

Office Action for U.S. Appl. No. 14/681,874 dated Jul. 23, 2015.

Patent Owner's Preliminary Response for Case No. IPR2015-01690 Dated Nov. 13, 2015.

Patent Owner's Preliminary Response for Case No. IPR2015-01691 Dated Nov. 18, 2015.

Canadian Office Action for Application No. 2,800,414 dated Jul. 15, 2015.

Final Office Action for U.S. Appl. No. 14/657,837 dated Nov. 2, 2015.

Decision Denying Institution (IPR2015-01690), *Allsteel v. DIRTT Environmental Solution* dated Jan. 27, 2016.

Decision Granting Institution (IPR2015-01691), *Allsteel v. DIRTT Environmental Solutions* dated Feb. 2, 2016.

Notice of Allowance for U.S. Appl. No. 29/492,776 dated Jan. 21, 2016.

Notice of Allowance for U.S. Appl. No. 29/493,280 dated Jan. 21, 2016.

Notice of Allowance for U.S. Appl. No. 14/657,837 dated Apr. 12, 2016.

Final Written Decision (IPR2015-01691), *Allsteel v. DIRTT Environmental Solutions* dated Jan. 19, 2017.

Non-Final Office Action for U.S. Appl. No. 14/681,874 dated Jun. 15, 2016.

Office Action for U.S. Appl. No. 14/032,931 dated Jul. 16, 2015.

Restriction Requirement for U.S. Appl. No. 14/683,684 dated Oct. 5, 2017.

* cited by examiner

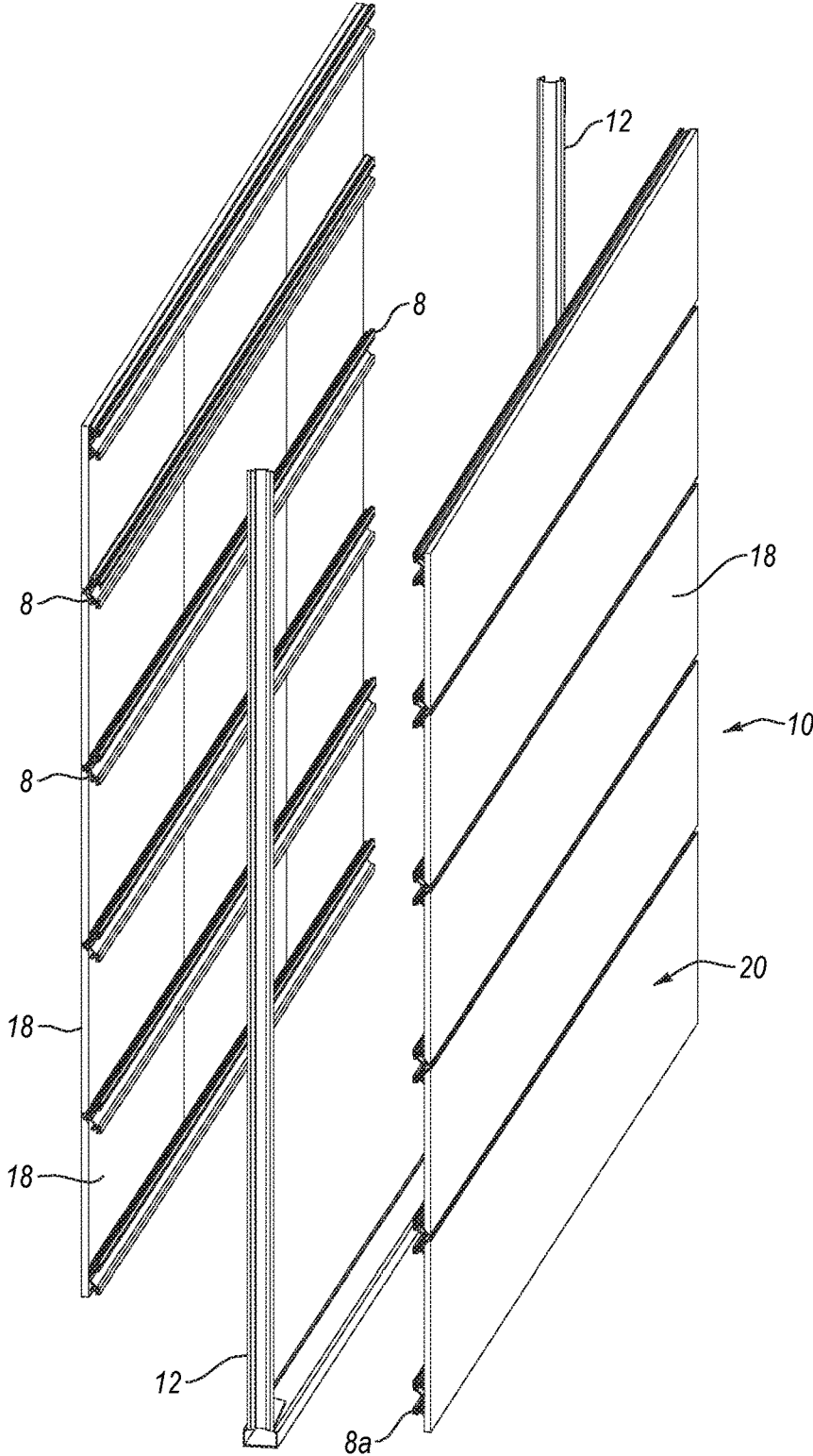

AMENDED
Figure 1

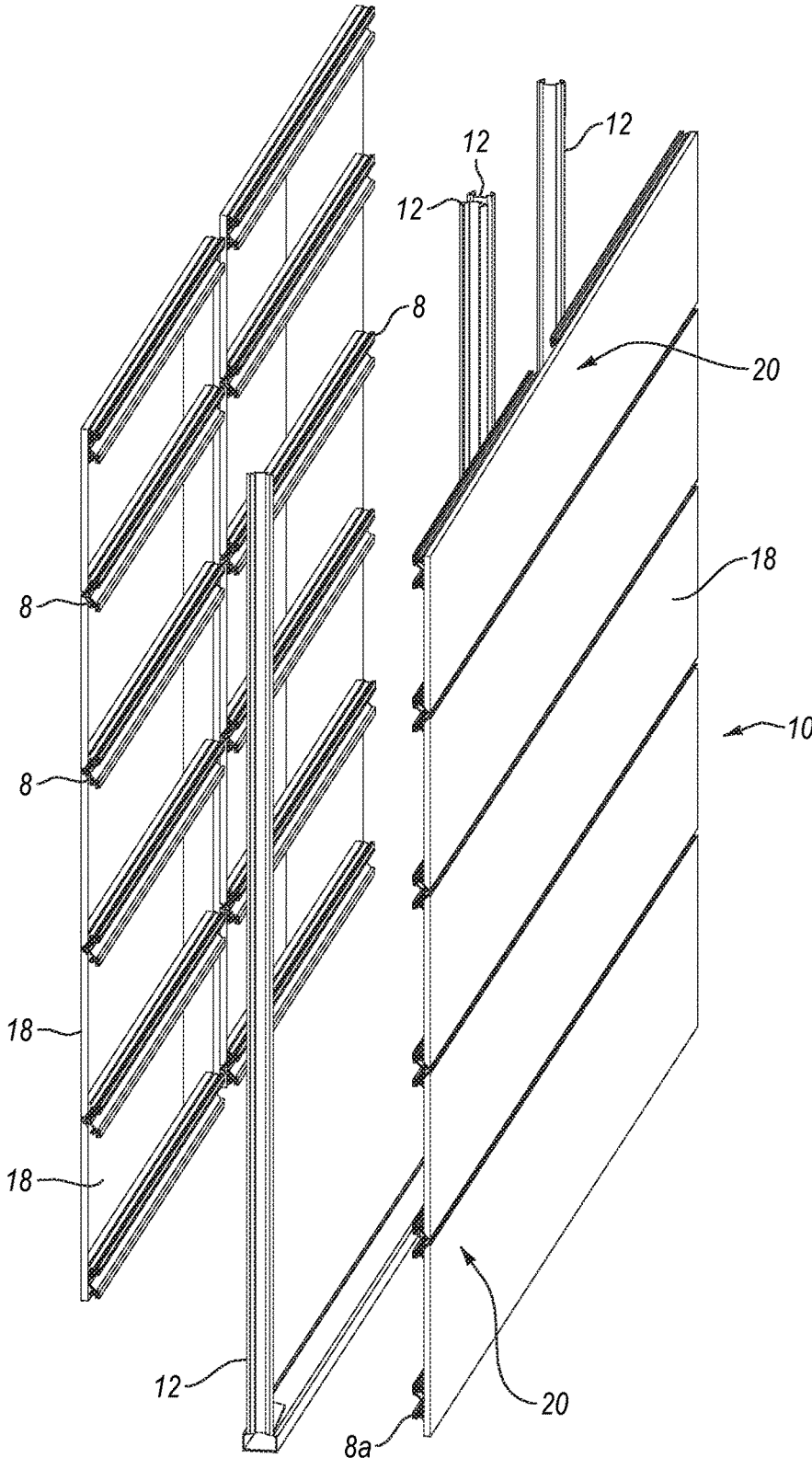

- NEW -
Figure 1A

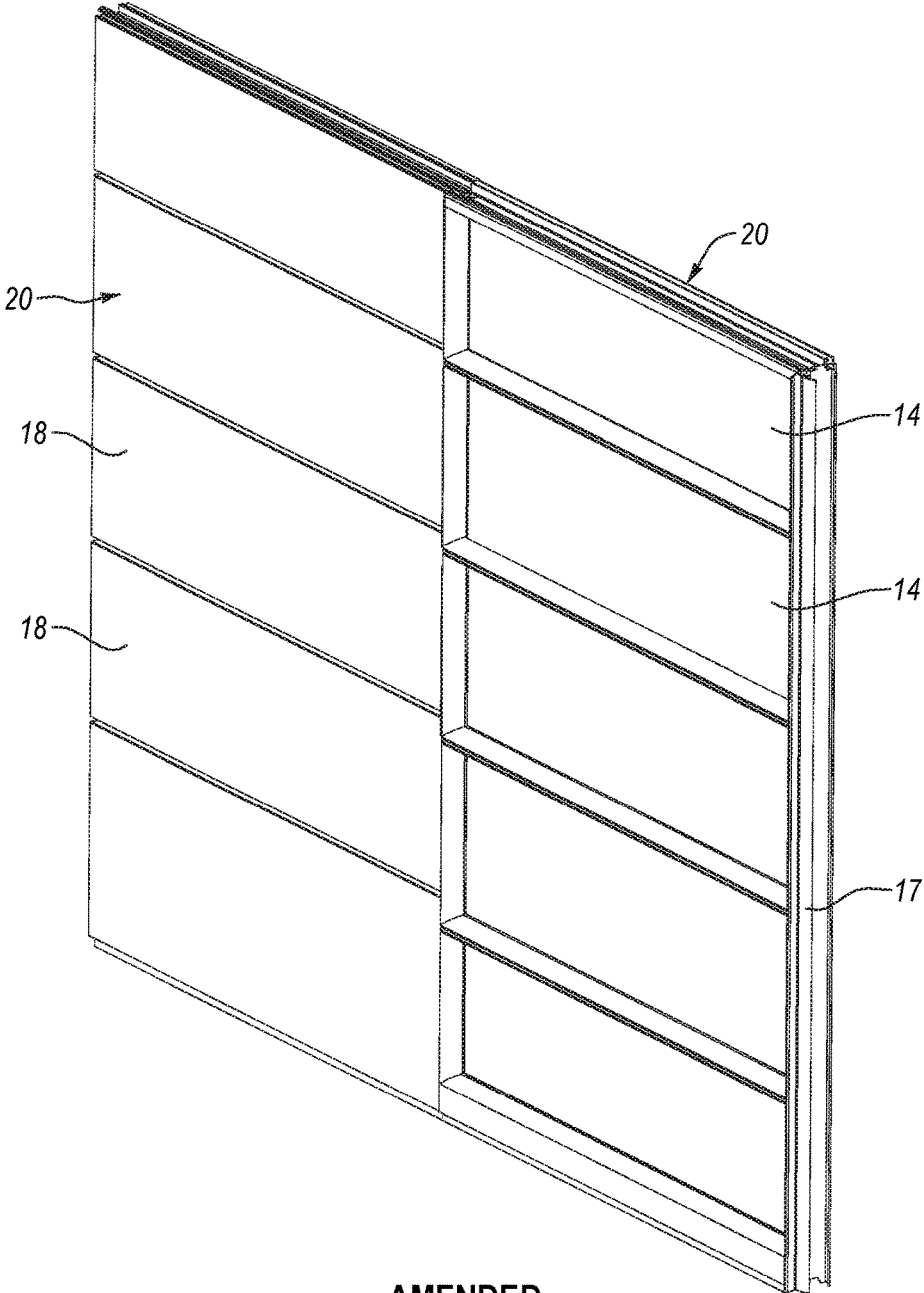

AMENDED
Figure 2

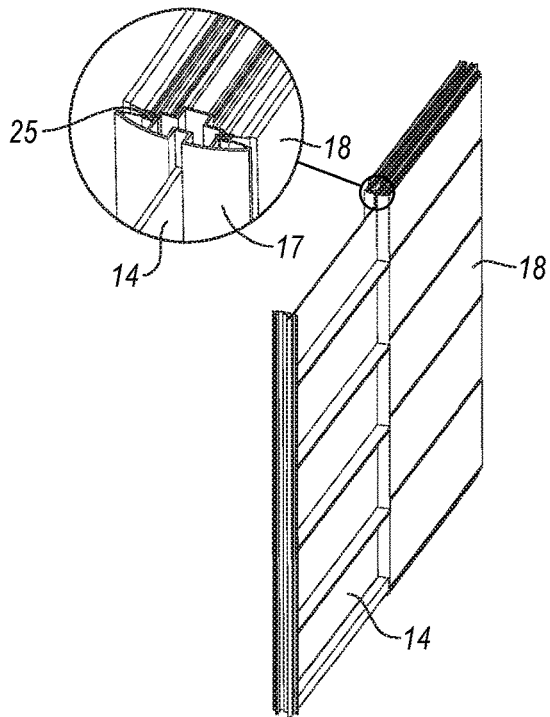
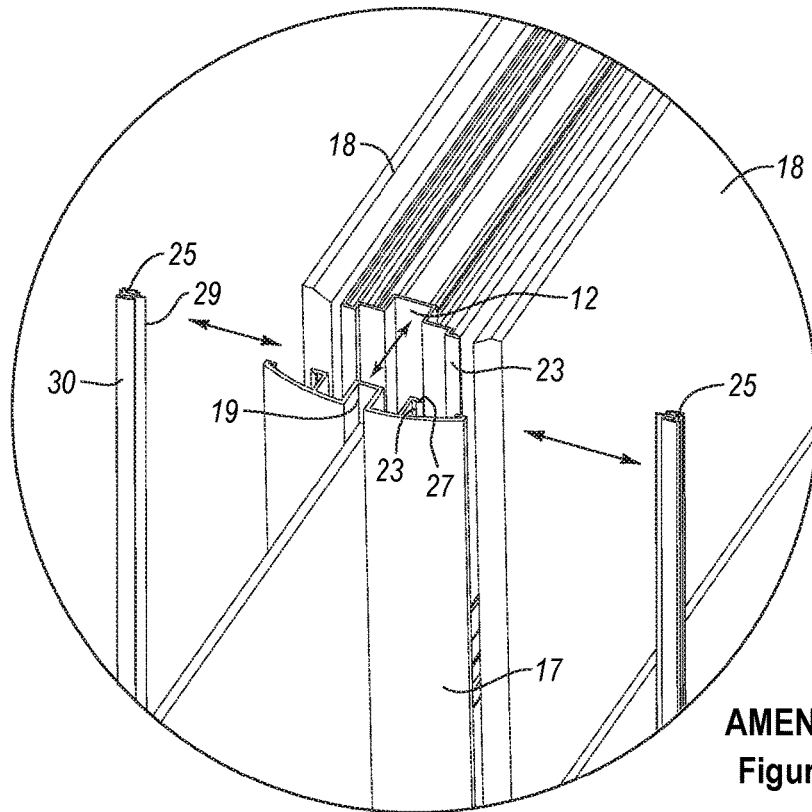

Figure 3



AMENDED
Figure 4

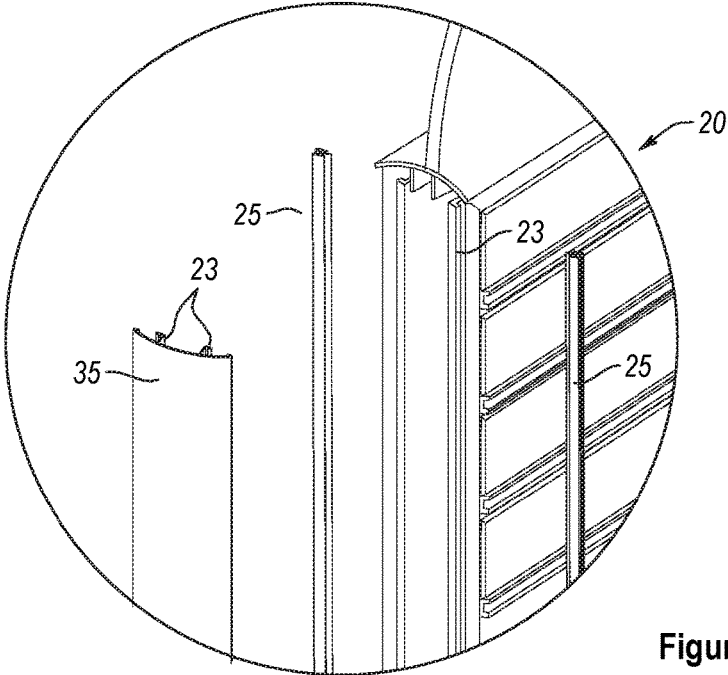
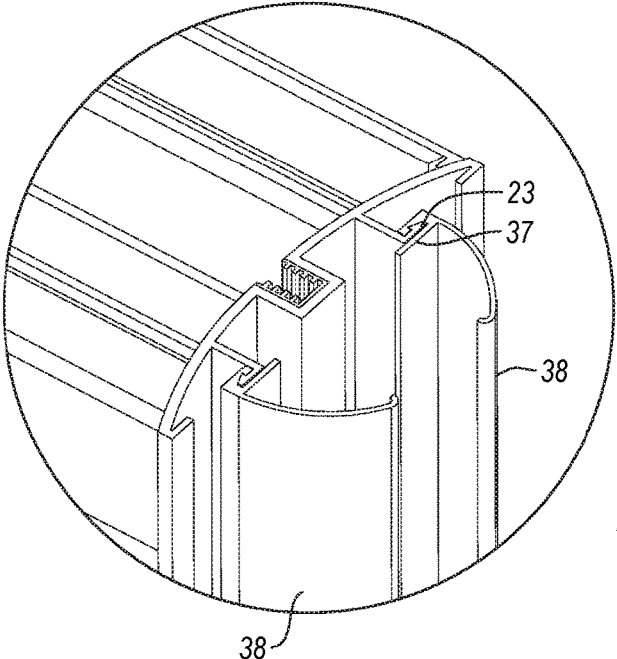
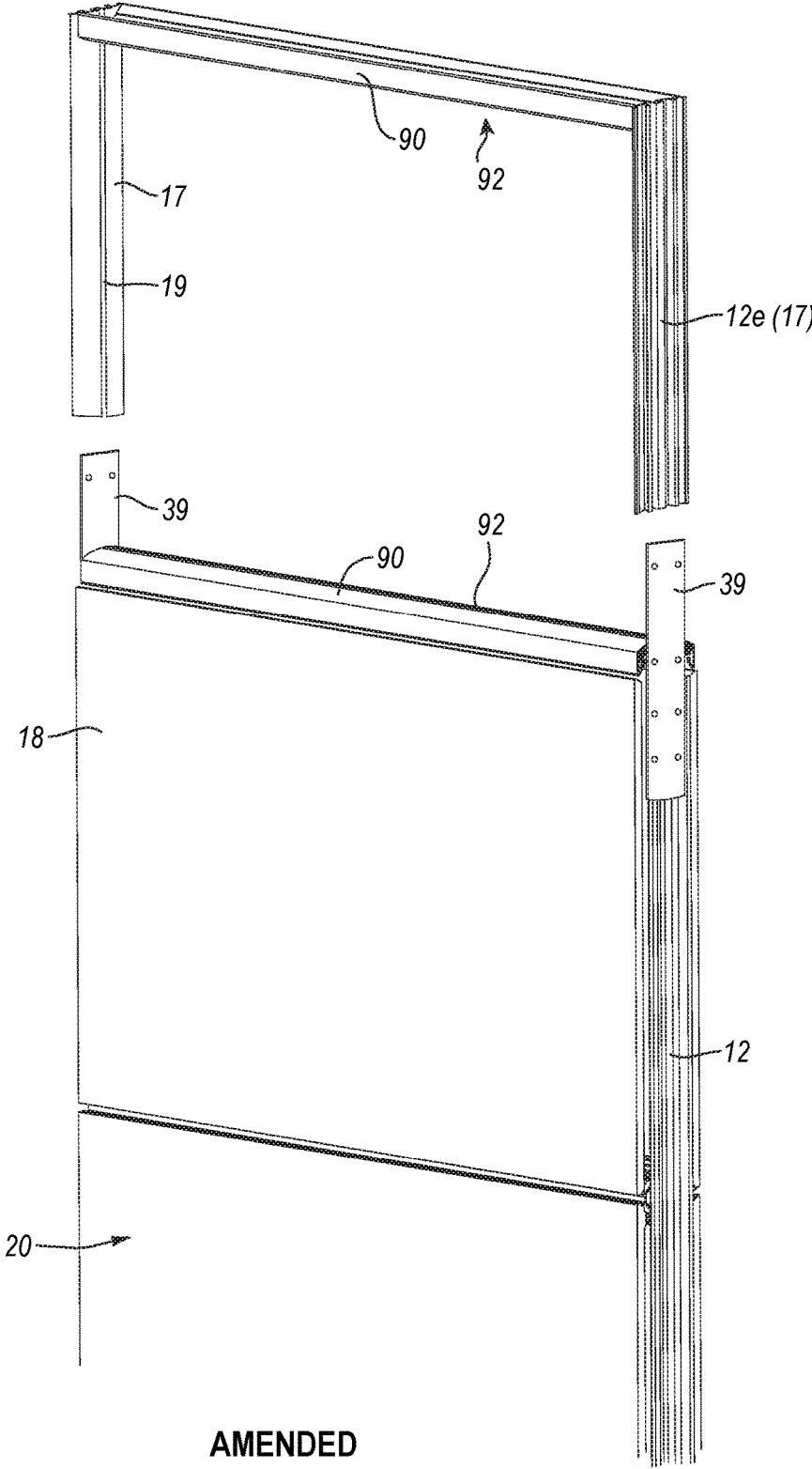

Figure 5



AMENDED
Figure 6



AMENDED
Figure 7

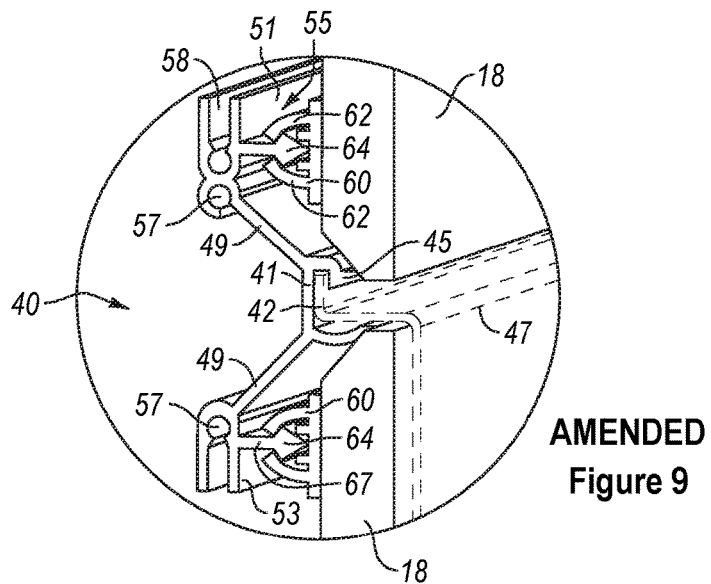
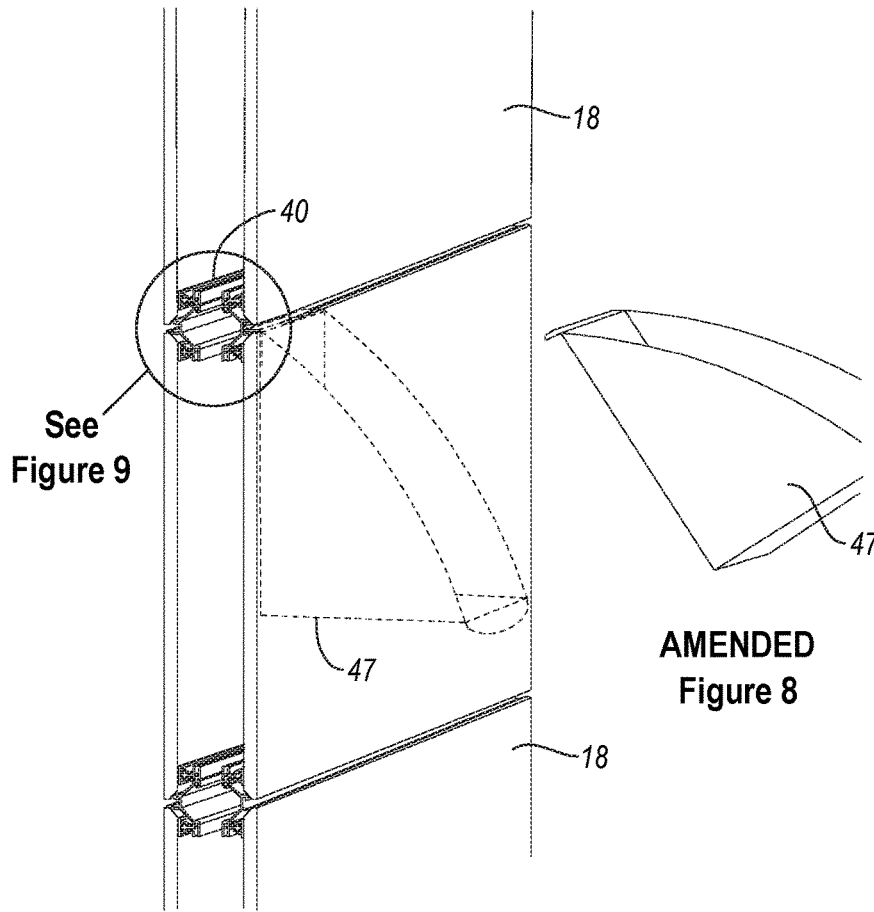

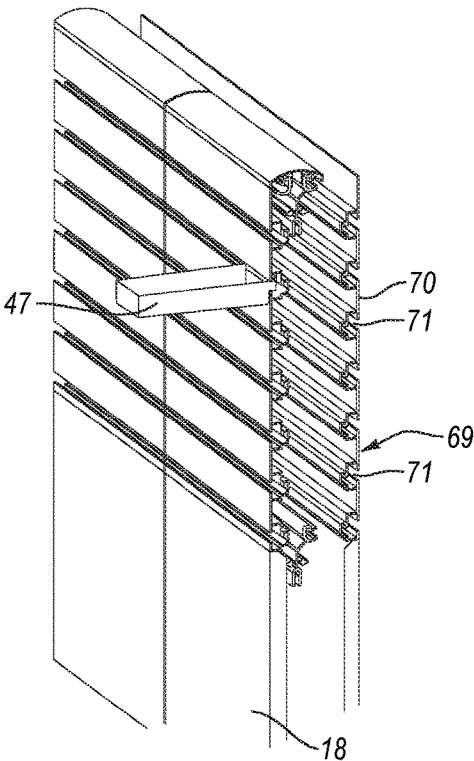

Figure 10

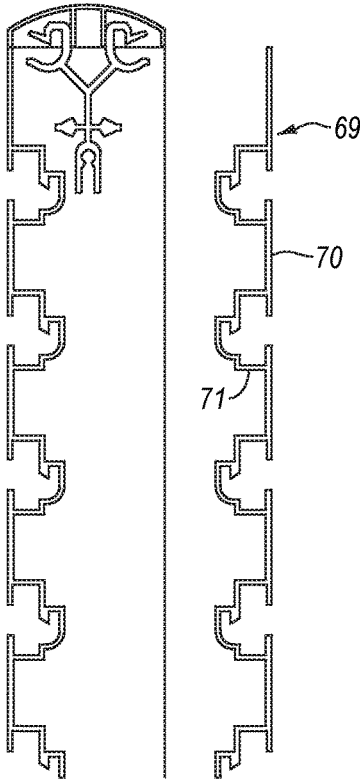

Figure 11

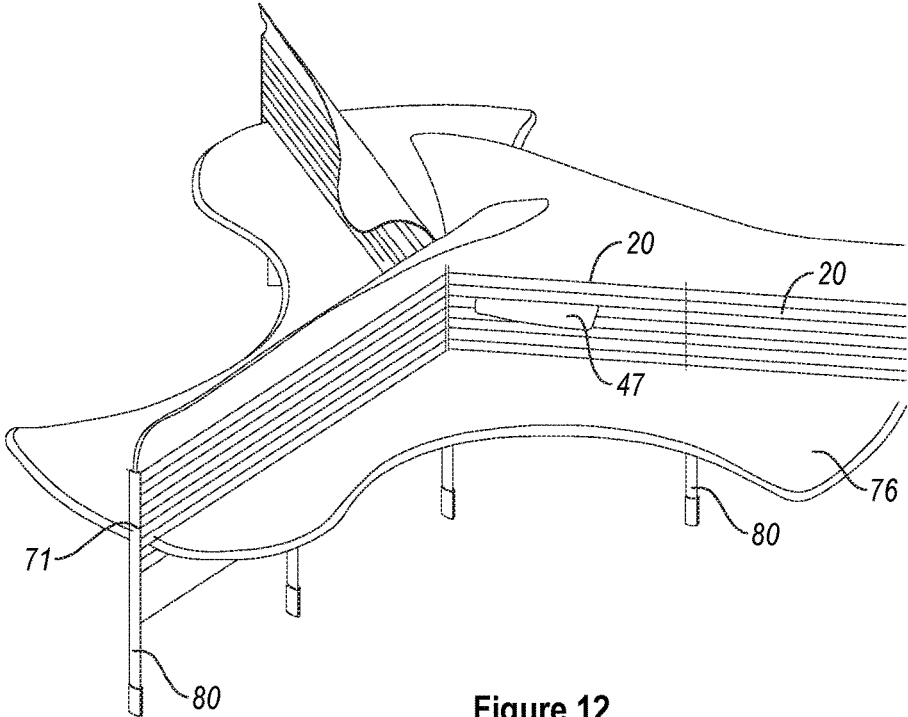
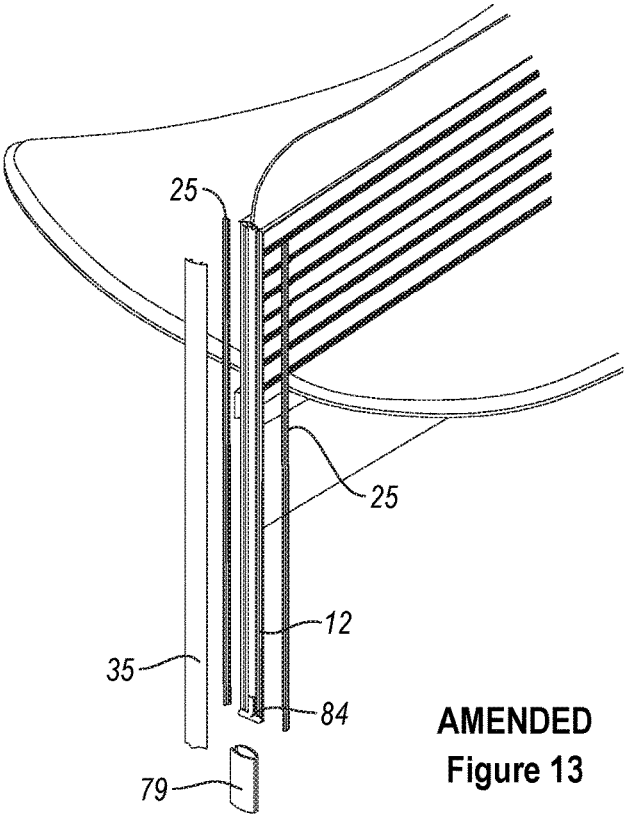

Figure 12



AMENDED
Figure 13

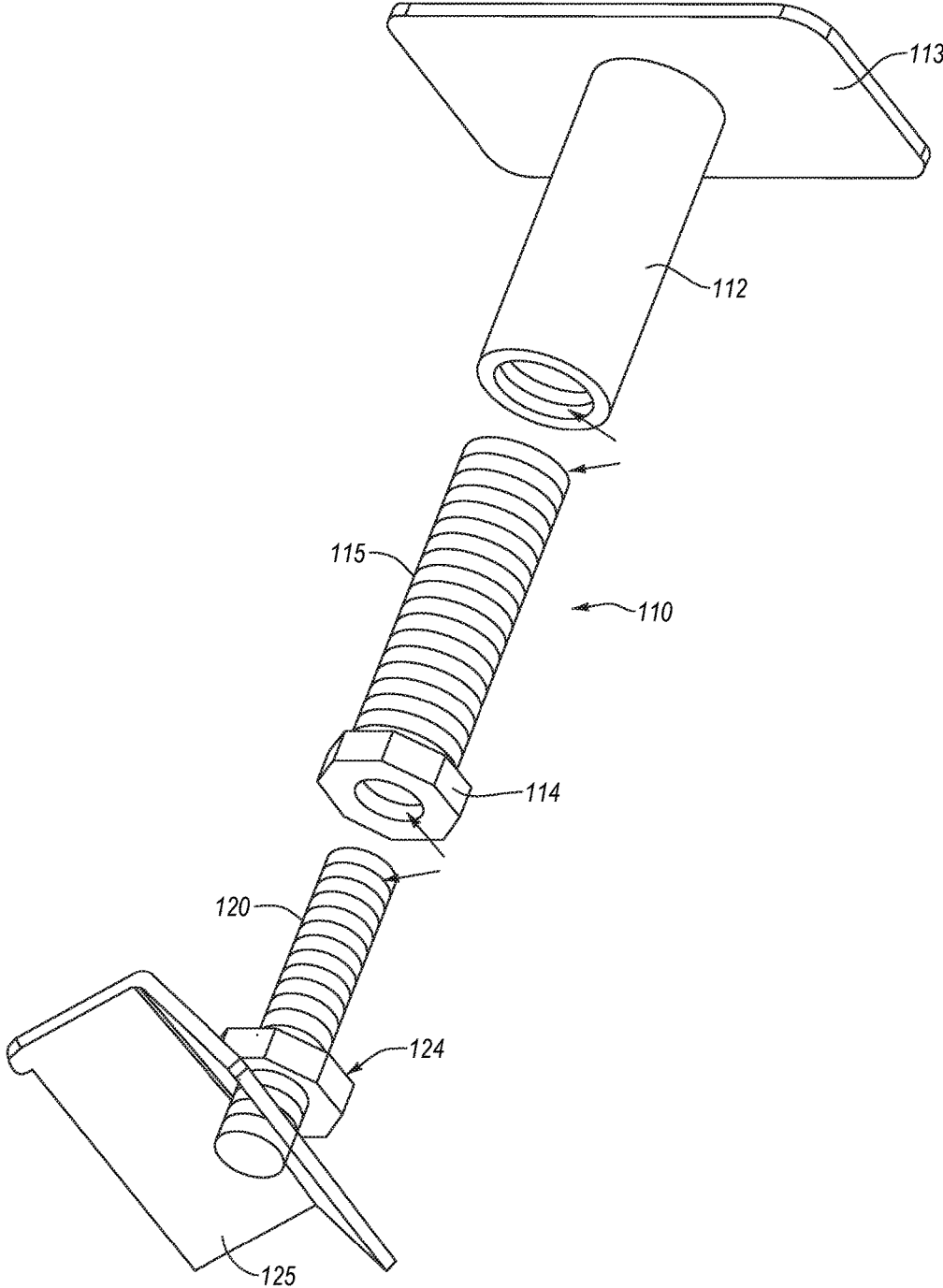
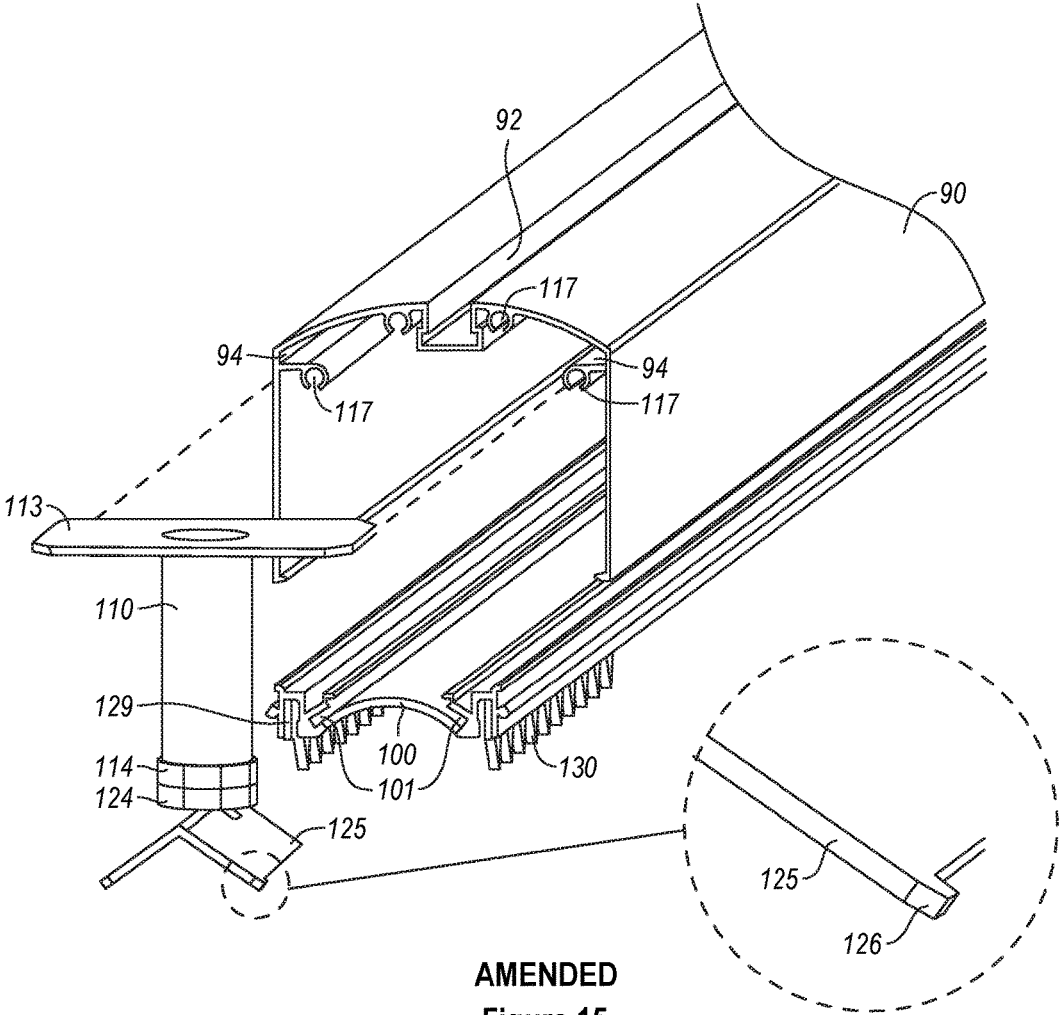
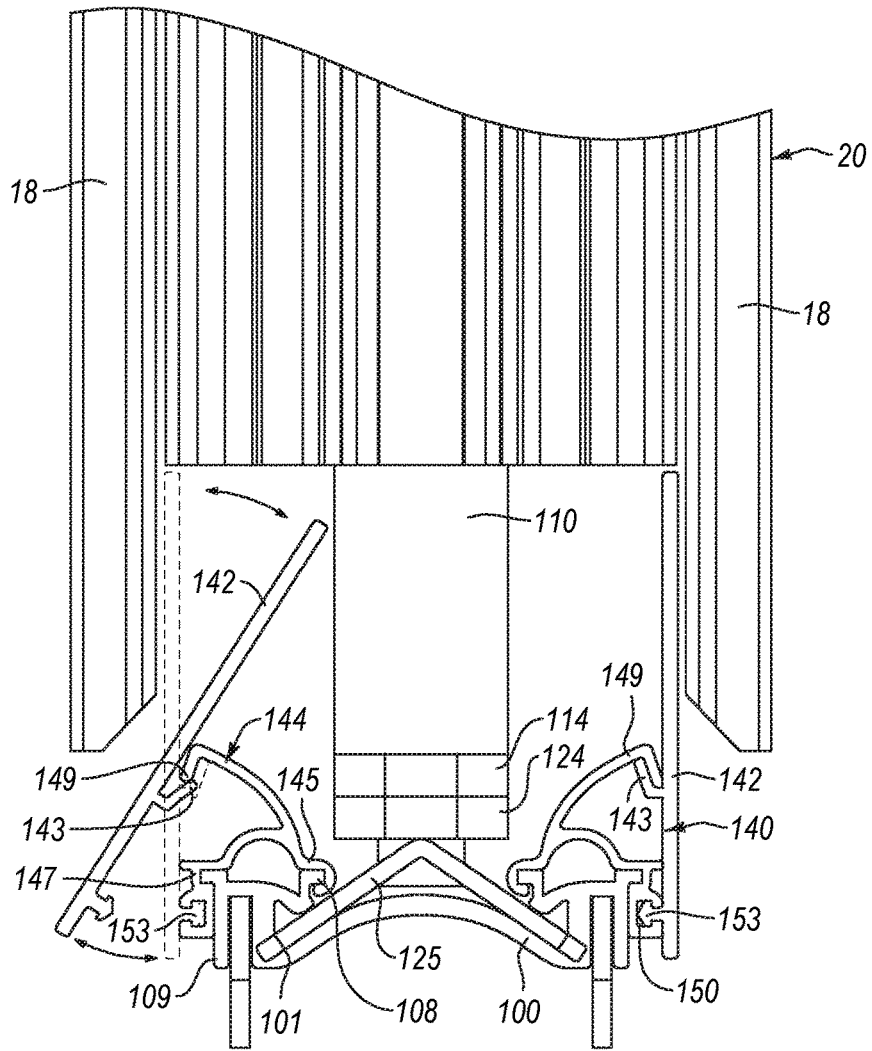

Figure 14



AMENDED
Figure 15



AMENDED
Figure 16

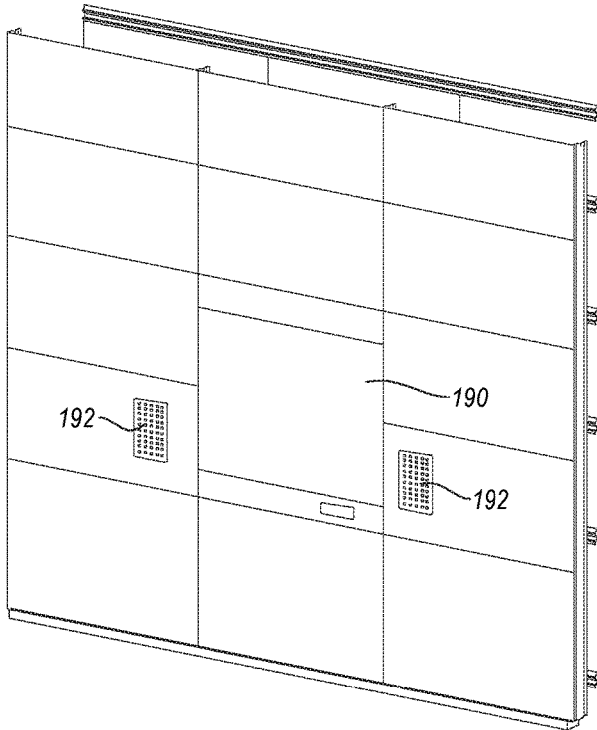

AMENDED
Figure 17

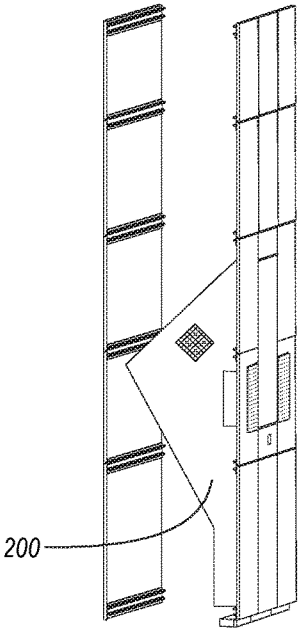

AMENDED
Figure 18

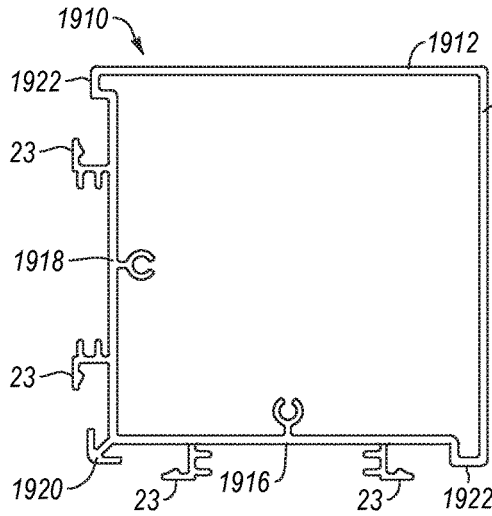

Figure 19

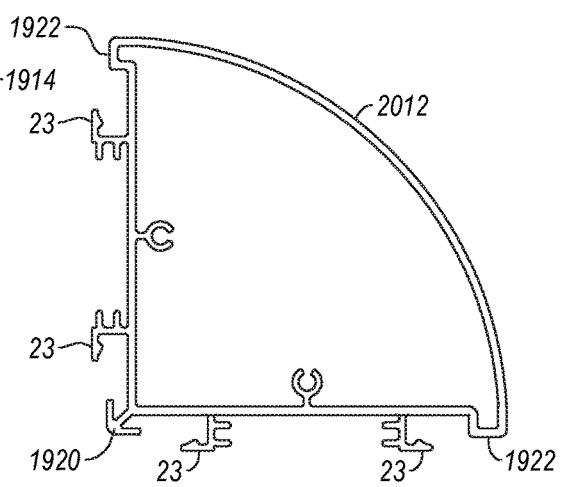

Figure 20

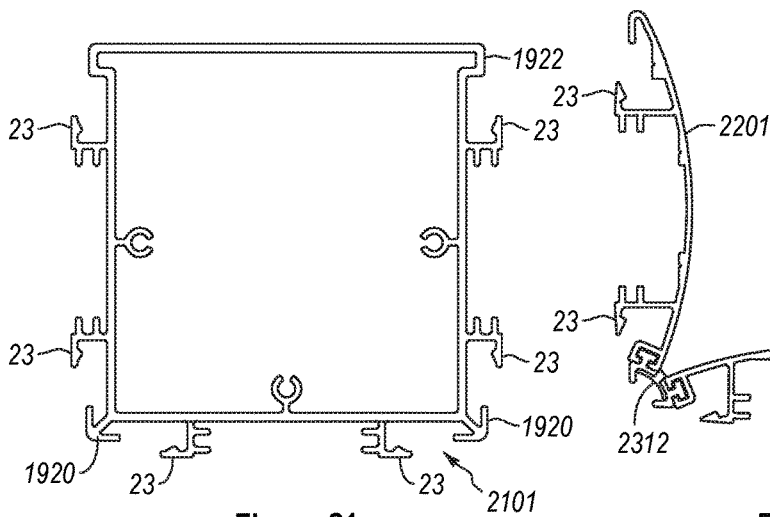

Figure 21

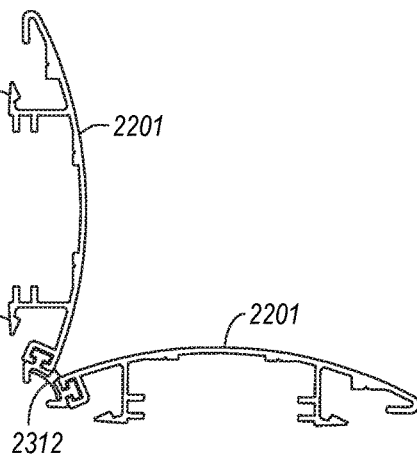

Figure 22

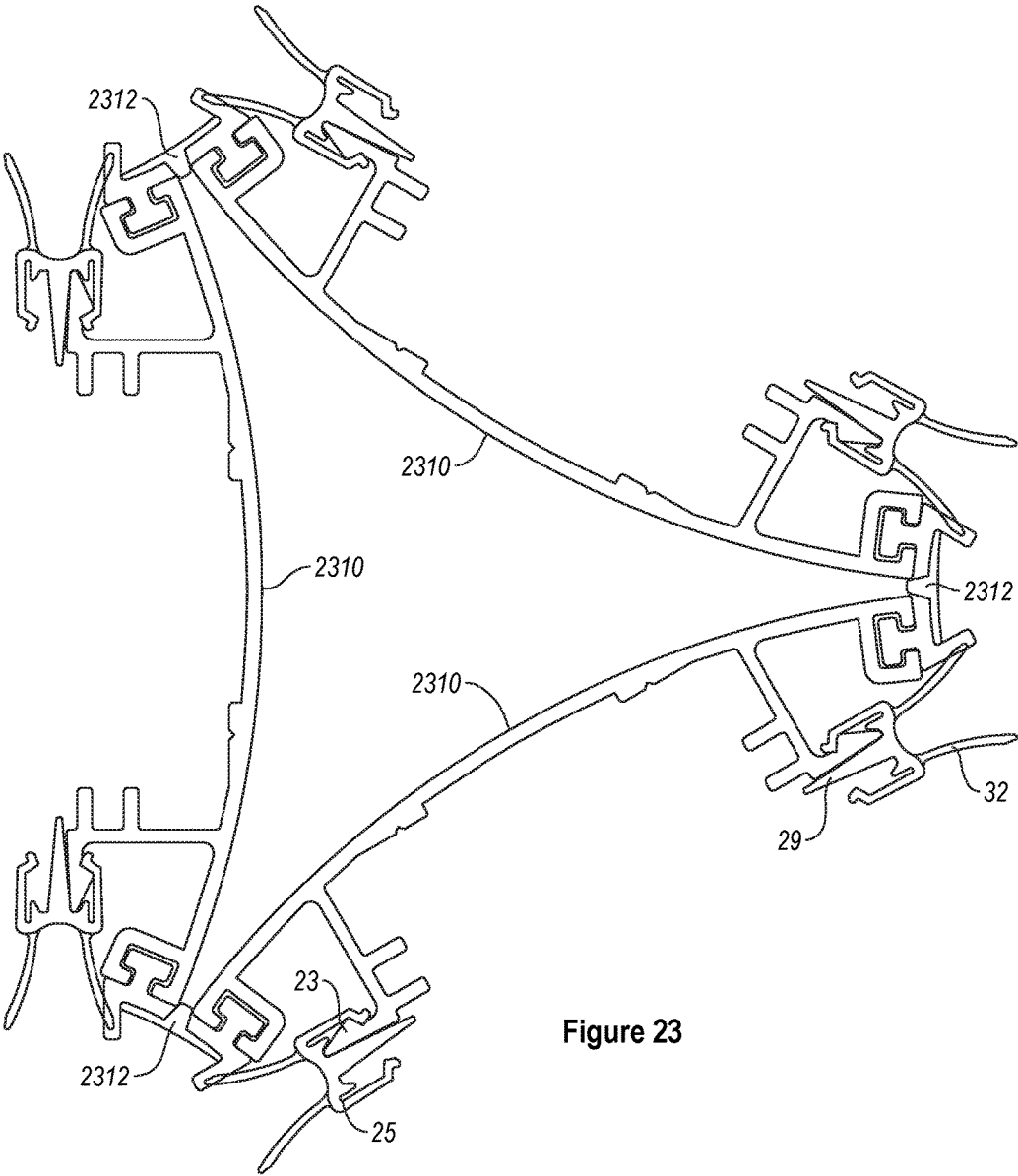
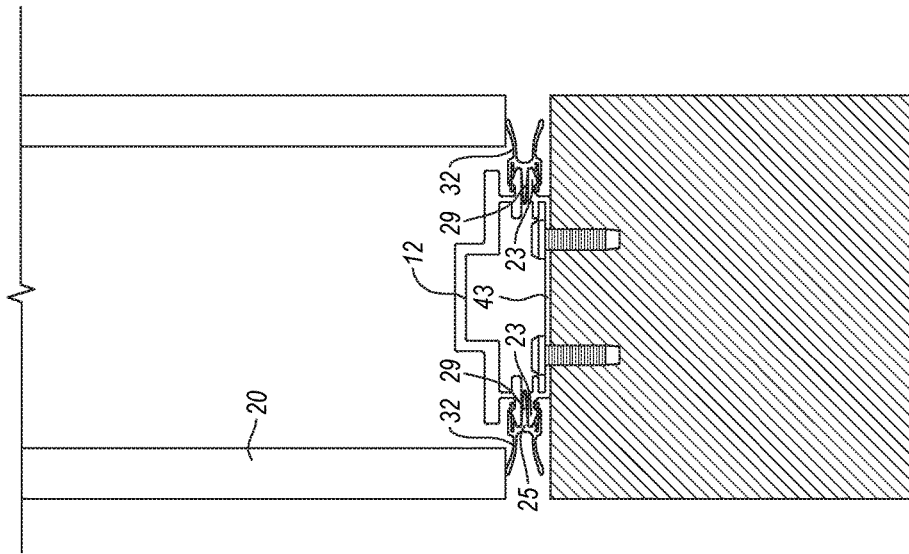

Figure 23



AMENDED
Figure 25

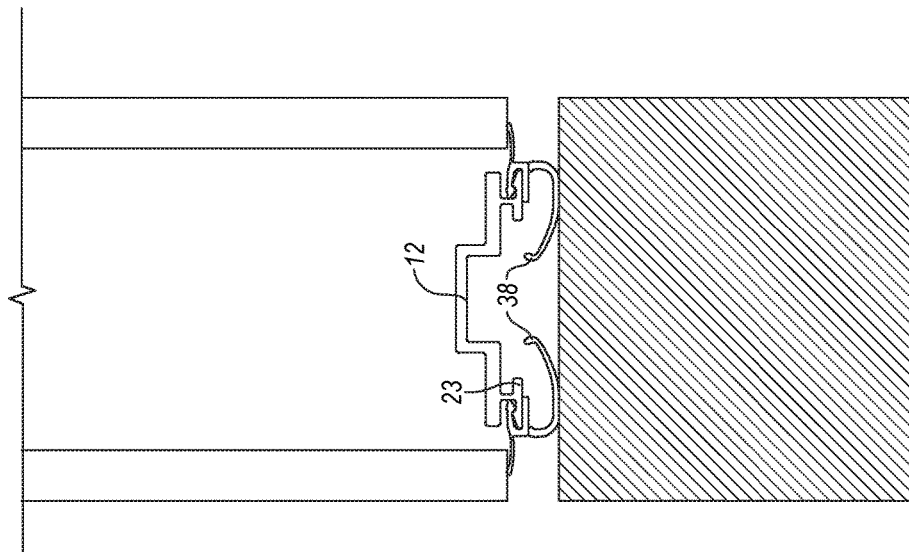
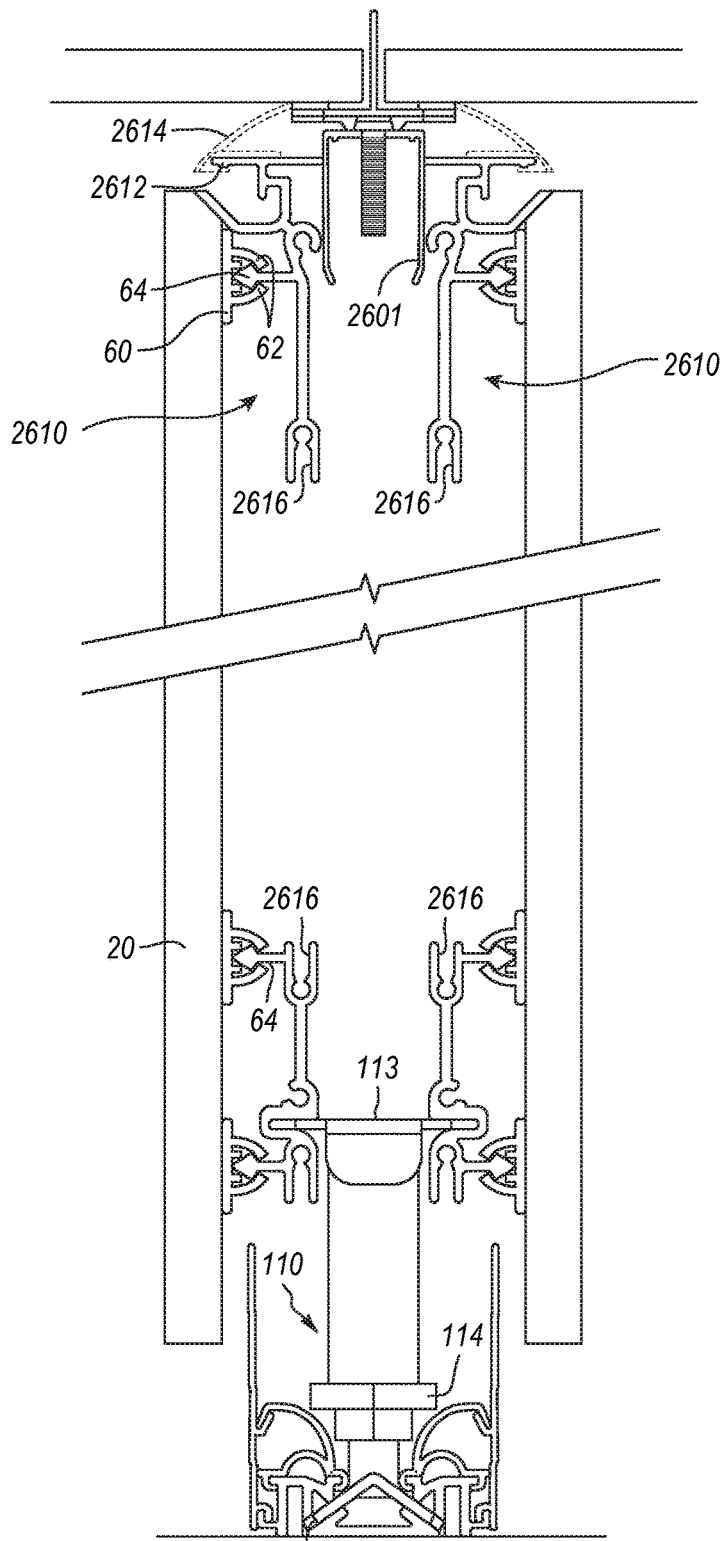

Figure 24



125 AMENDED
Figure 26

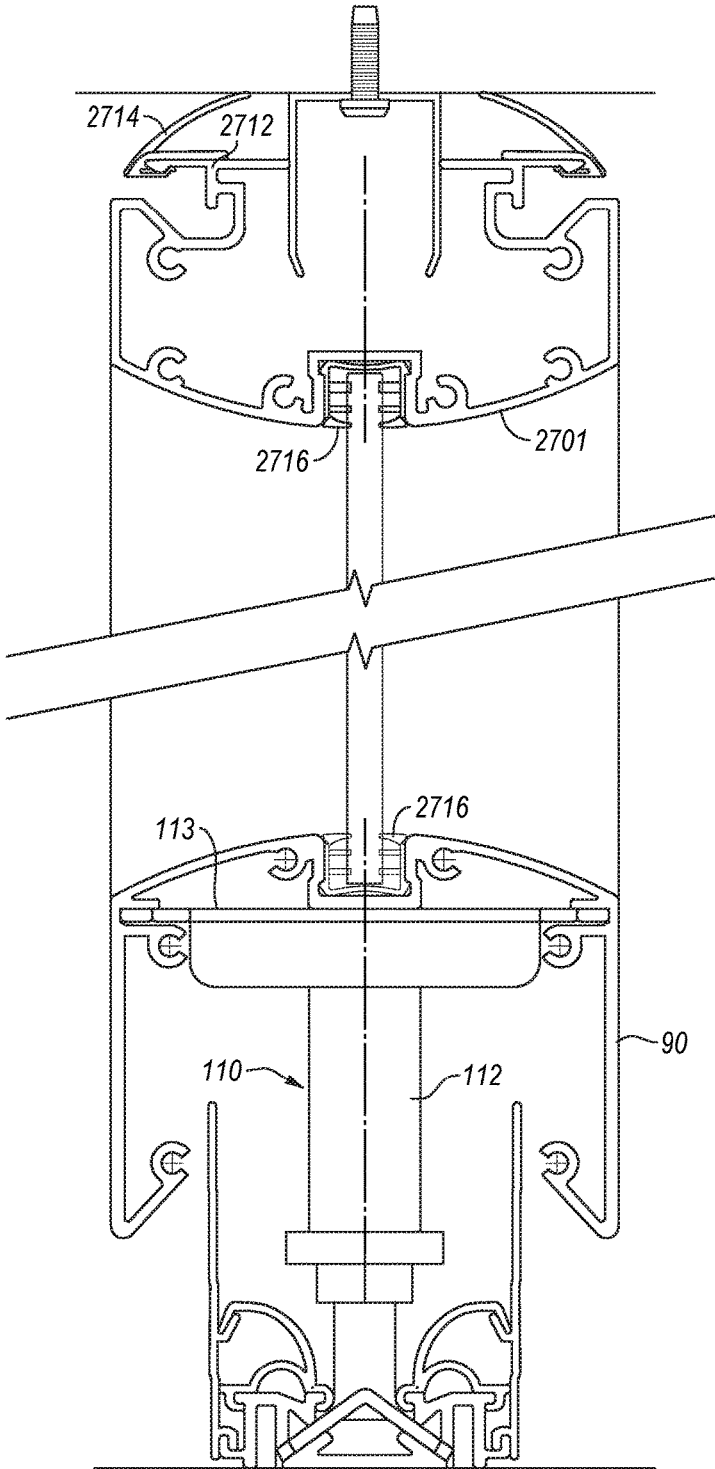
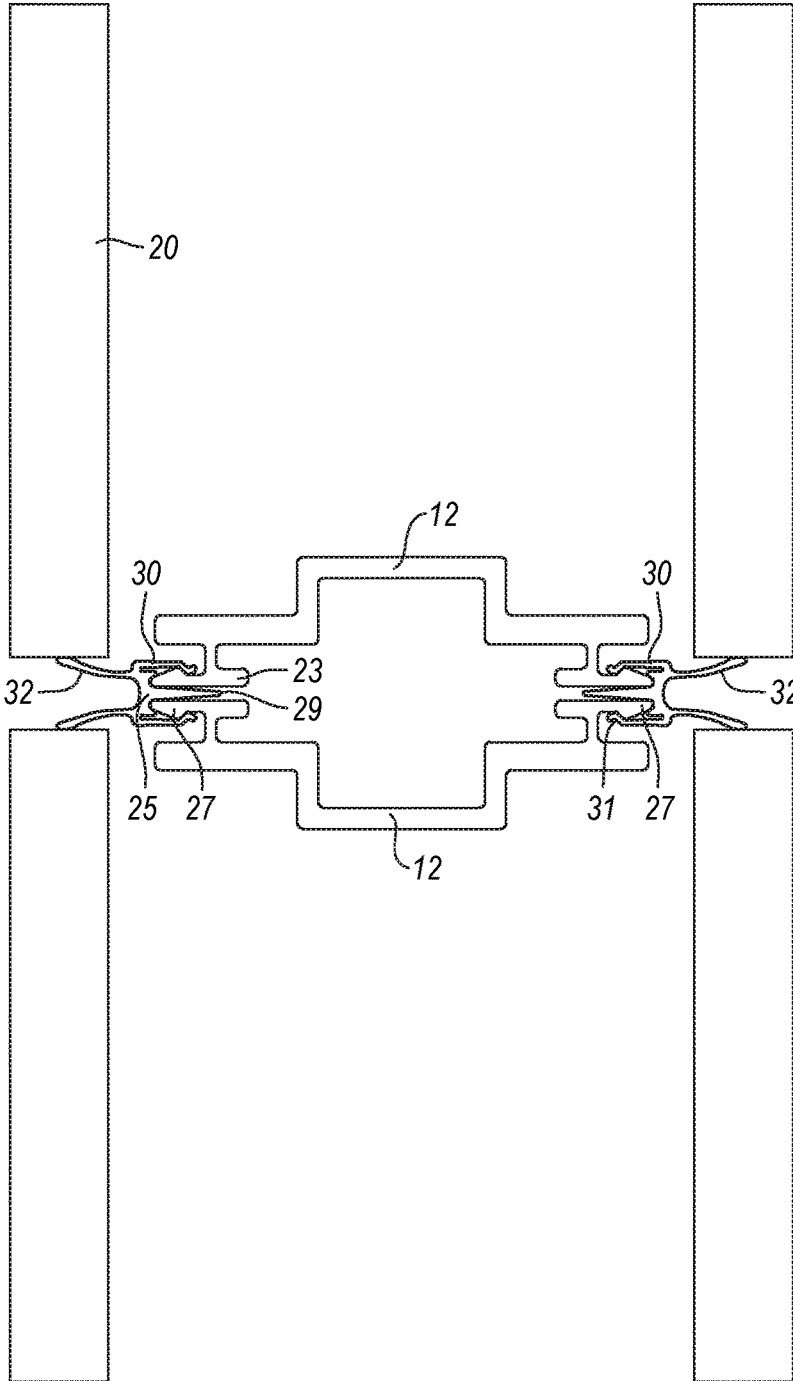

Figure 27



AMENDED
Figure 28

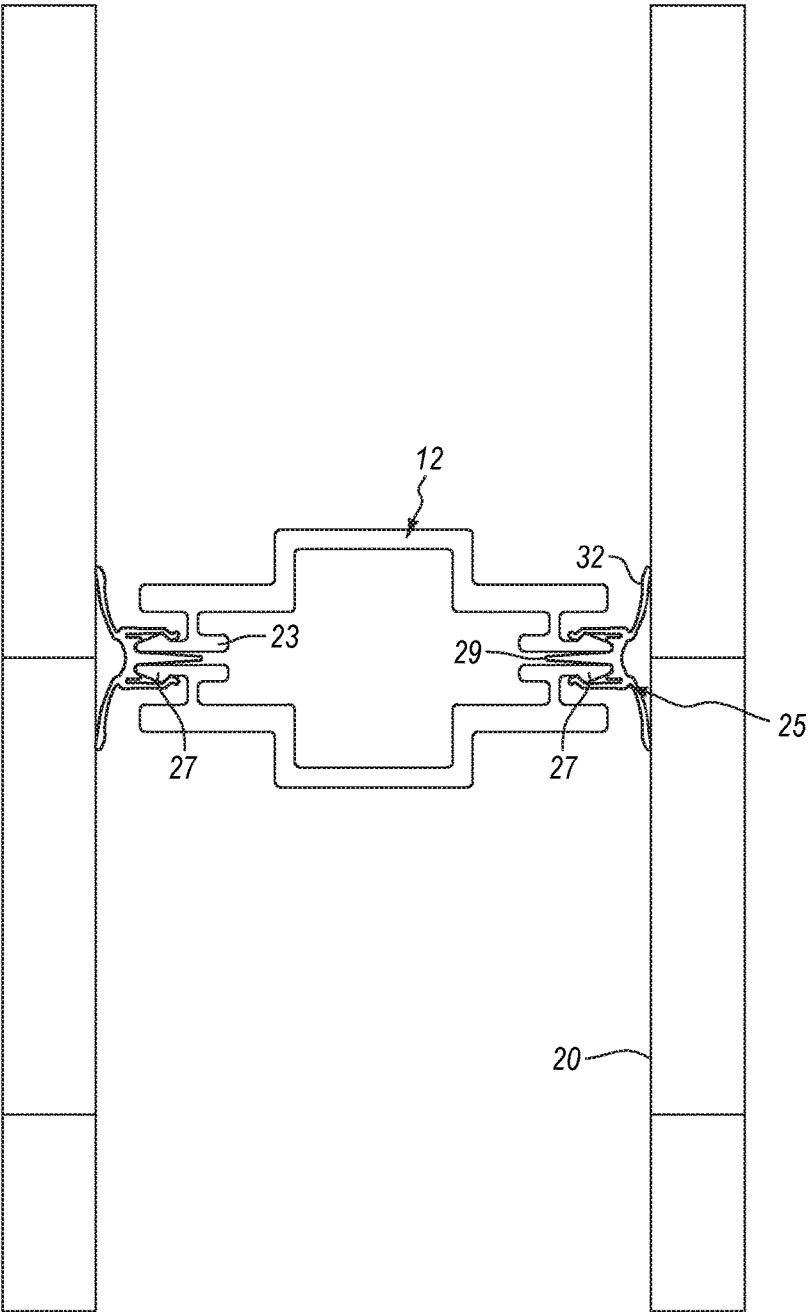

Figure 29

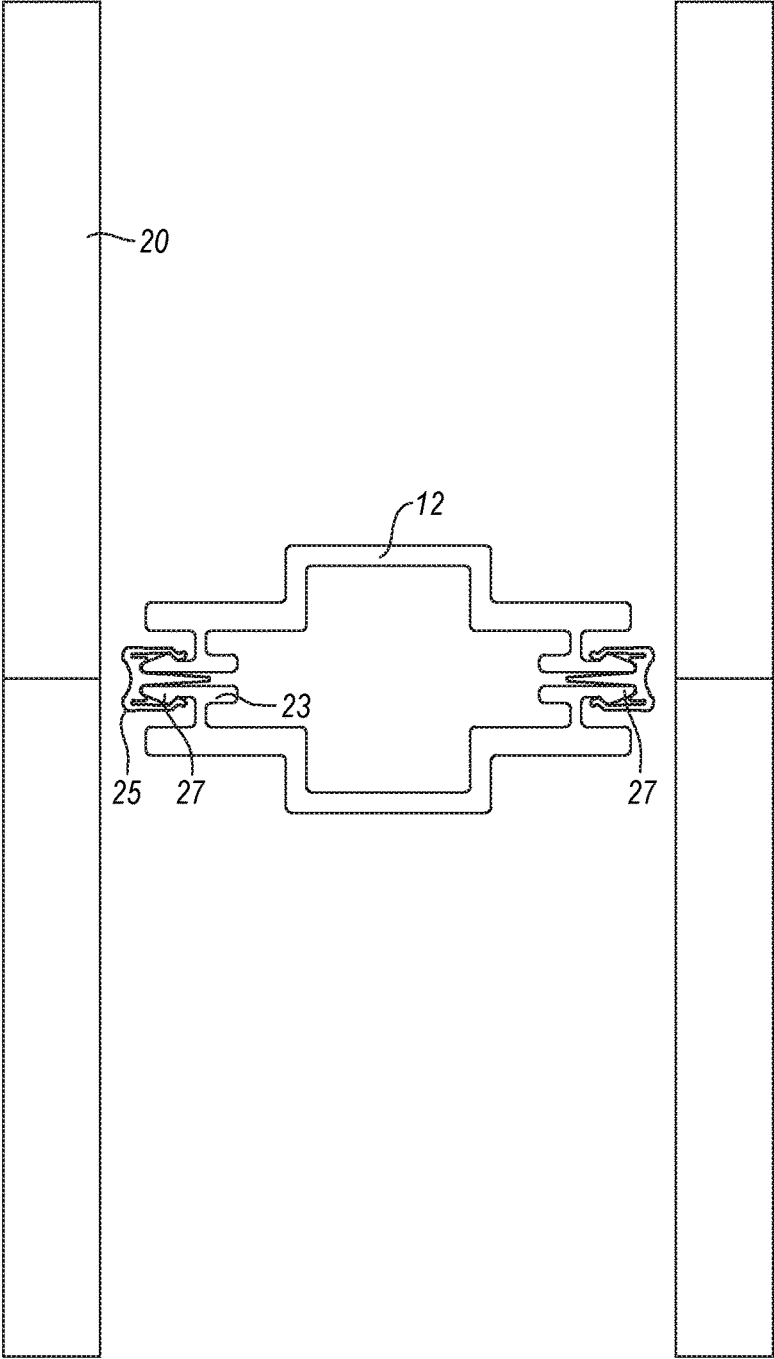

Figure 30

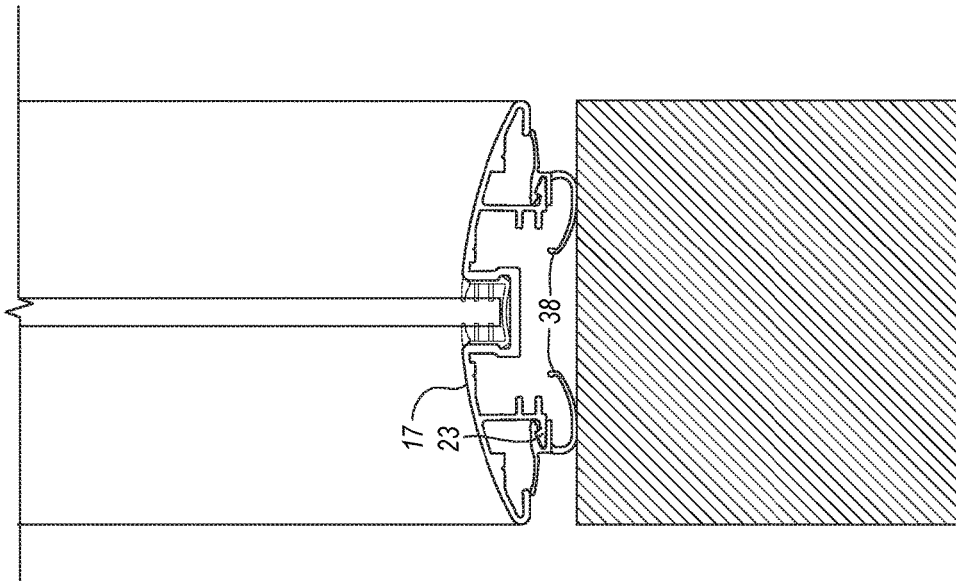
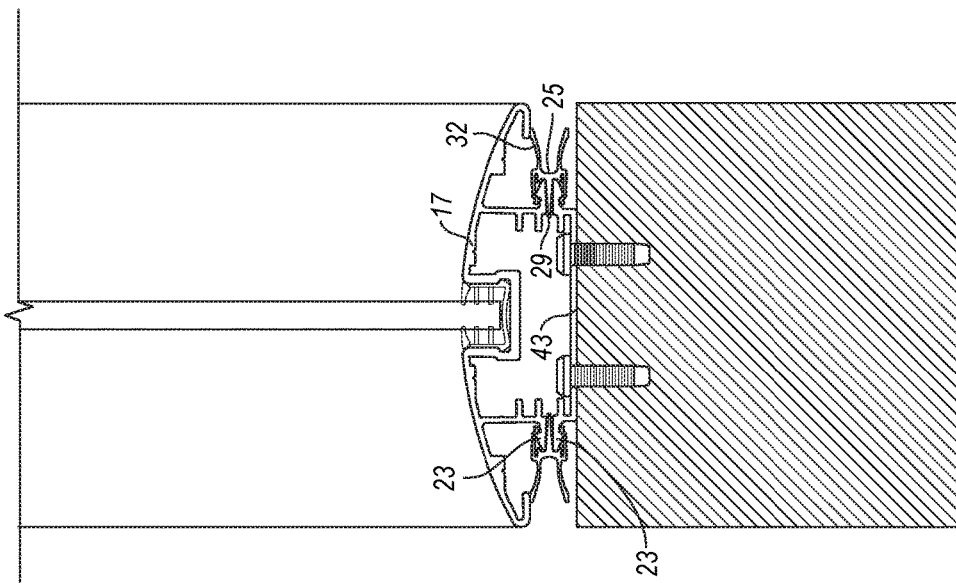

Figure 32



AMENDED
Figure 31

INTEGRATED RECONFIGURABLE WALL SYSTEM

Matter enclosed in heavy brackets [] appears in the original patent but forms no part of this reissue specification; matter printed in italics indicates the additions made by reissue; a claim printed with strikethrough indicates that the claim was canceled, disclaimed, or held invalid by a prior post-patent action or proceeding.

CROSS-REFERENCE TO RELATED APPLICATIONS

[The present invention] *Notice: More than one reissue application has been filed for the reissue of U.S. Pat. No. 8,024,901. The reissue applications are the present application, Reissue application Ser. No. 14/032,931, Reissue Divisional application Ser. No. 14/681,874, and Reissue application Ser. No. 15/074,383. This application is a continuation reissue of application Ser. No. 14/032,931, entitled "INTEGRATED RECONFIGURABLE WALL SYSTEM", filed Sep. 20, 2013, which is an application for reissue of U.S. Pat. No. 8,024,901, which claims the benefit of the filing date of U.S. Provisional Patent Application Ser. No. 60/601,985, entitled "INTEGRATED RECONFIGURABLE WALL SYSTEM", filed Aug. 17, 2004.*

FIELD OF THE INVENTION

The present invention relates to a wall moveable system, and more particularly to a reconfigurable moveable wall system comprising reconfigurable components and design elements.

BACKGROUND OF THE INVENTION

Wall systems, or dividers as they are sometimes called, are used most commonly in an office environment to separate work areas and to give people privacy where permanent walls are lacking. It is beneficial to have a wall system that is easily movable and easily reconfigured given the ever changing needs and requirements in these environments. Another important aspect in an office is to maximize available space. Aesthetics are also important, including the ability to provide the aesthetic element independently of underlying structural componentry.

Previous wall systems have lacked some or all of these attributes. Some are difficult to reconfigure or to move without significant amounts of labour and dislocation. Most systems lack the flexibility to quickly change the height of a wall, or to use or substitute different types of panels, or replace a module in the middle of a wall without taking apart the entire wall. There also is a need to be able to use the wall system against an existing wall as a curtain wall for an integrated look and to provide the design flexibility needed in those spaces bordered by permanent walls.

SUMMARY OF THE INVENTION

In a preferred embodiment, the present wall system comprises at least one module, where each module includes a frame and a plurality of tiles mounted to the frame by means of a tile clip system. Clips are attached to the rear surface of each tile and the tile is then pressed into place, aligning the clips with a capture detail on the horizontal frame stringers. Tiles can span adjacent frames where required. Horizontal

frame stringers may include a cantilever channel detail where desired to allow objects to be hung along the width. A single frame comprised of two verticals frame members and a plurality of horizontal stringers mounted to an existing wall by connecting the horizontal members to brackets attached to the existing wall allows tiles to be mounted as a curtain wall on the existing wall. Two frames may be supported back to back within a framework for modules used to divide adjacent work spaces. A spline is attachable to the top of the frame to extend the frame and allow for additional tiles to be added on to increase a module's height if so desired. The spline is also used to connect a different style of frame above the existing frame if so desired. For example, this allows a framed glass module to be attached above a framed wood substrate module. Two adjacent modules are connected using a removable zipper interface. The zipper contains two flexible gasket components. Where tiles will span adjacent frames or meet one another without a gap, the gaskets bend back behind the tiles. Where tiles do not span adjacent frames and a gap is wanted, the gaskets point outward from the frame, between the tiles. At the edge of a module where no other module is to be connected, a starter strip may be placed, wherein the starter strip includes an integral flexible gasket which conforms to the shape of the surrounding environment while providing both light and sound baffling. The cantilever channel between tiles allows for various accessories or mill work to be supported from the outside of the module at convenient locations and to be adjusted as needed.

The present wall system also includes a glass wall module, where each module includes a frame and a plurality of glass tiles mounted within the frame. The glass may be center mounted, front mounted or rear mounted. A channel within each end frame extrusion holds a full length gasket extrusion or notch. The glass is retained within the gasket extrusion, around the full perimeter of the glass tile. Extra horizontal or vertical extrusions are attached within the frame to further divide the module into smaller areas.

The present wall system also includes levelers. Levelers include upper, middle and lower sections. The upper section includes a hollow cylinder which is threaded along the interior, and a flat upper plated perpendicular to the leveler. The middle section is a hollow cylinder where the interior and exterior surfaces are threaded in opposite directions, with a fixed nut at one end of the middle section for adjustment. The lower section includes a solid cylinder threaded to correspond with the middle section, a fixed lower nut and an inverted V-shaped lower plate. The leveler is used by having the flat plate in the upper section engage a continuous channel in an the lowermost extrusion of a module's frame, and the lower plate engaging a continuous universal foot, located beneath each module. The V-shape of the lower plate distributes the weight of the wall in the direction of the connection channels of continuous universal foot. A leveler can be placed at any location along the width of the module, allowing for a plurality of levelers to be used if needed. Along the base of the universal foot is a plurality of grippers, which can be adapted for either carpet or hard flooring surfaces. The attachment of the leveler to the module is secure and without extra fastener requirement of any sort. Sliding the leveler plates into the extrusion channels, followed by the attachment of subsequent vertical members, secures the levelers in place.

A base trim is provided which, in one embodiment, can be removably secured to the universal foot to provide access to

3

the levelers when needed but which otherwise provides a finished look to the modules. The base trim can be modular, or span multiple frames.

Wall modules can be adapted to include integrated rear projection video systems or digital whiteboards. Front projection screens or whiteboards can be mounted within the frame confines, or spanning adjacent frames.

The present wall system provides for true curved walls. Curved wall frames are comprised of straight vertical extrusions and stretch formed horizontal extrusions which are curved to the required radius. Glass or other substrate tiles are curved to match the radius of the frame and mounted in the same manner as planar wall modules.

The present wall system can incorporate universal slat wall constructions which would accept all standard slat wall accessories. The slat wall component is a horizontal structural extrusion, interlocking above and below the cantilever channel horizontal member or other slat wall extrusions.

The present wall system can also support desktops and work surfaces using support brackets in the cantilever channel.

The present wall system also integrates completely with a related furniture panel system. A furniture panel system is comprised of a frame and plurality of tiles attached to the frame. The furniture panel system is designed to serve as cubicle type dividers or desk type units, rather than full height walls. The integration to the furniture panel system is seamless, as the zipper connection detail, tile clip capture detail and cantilever detail are identical to the wall system connection details. All components used in or on the wall system can also be used in or on the furniture panel system.

According to the present invention then, there is provided a movable reconfigurable wall system comprising: at least one module having a front and rear surface, said at least one module having: vertical end frames disposed at least at its side edges, each said vertical end frame having a vertically extending flange directed toward said front surface and a vertically extending flange directed toward said rear surface; a plurality of horizontal stringers affixed between said pair of vertical end frames; and an aesthetic surface affixed to said stringers; and a removable connecting strip, said connecting strip adapted to affix about one of said two flanges on one of said vertical end frames and join said one of said two flanges to a corresponding flange on one of a second module, a wall bracket, a finishing trim or a connection post.

BRIEF DESCRIPTION OF THE DRAWINGS

Preferred embodiments of the applicant's integrated reconfigurable wall system will now be described in greater detail and will be better understood when read in conjunction with the following drawings in which:

FIG. 1 is an exploded perspective view of a module representative of the present tile clad wall system;

FIG. 2 is a perspective view of a wall system including two adjacent modules, one tile clad and one glass wall;

FIG. 3 is an enlarged view of a portion of the wall system of FIG. 3 showing the connection between adjacent modules;

FIG. 4 is an exploded view of FIG. 3;

FIG. 5 is a perspective view of a frame member including a finishing trim;

FIG. 6 is a perspective view of a frame member including a wall starter trim where a module meets an existing wall;

FIG. 7 is a perspective view of a height extension to an existing module;

4

FIG. 8 is a perspective view of a portion of a wall module showing the orientation of horizontal members with integrated cantilever channel;

FIG. 9 is an enlarged view of a portion of FIG. 8 showing cantilever bracket details and tile clip connection details;

FIG. 10 is a perspective view of a wall panel incorporating slat wall construction;

FIG. 11 is a side elevational view of the slat wall construction of FIG. 10;

FIG. 12 is a perspective view of the related panel furniture system utilizing the same connectors and slat wall extrusion to support a work surface;

FIG. 13 is a perspective, partially exploded view showing the assembly of a leg used to support the panel furniture system, utilizing the same connection zipper as the wall components of FIG. 12;

FIG. 14 is a perspective, exploded view of a leveller for use with the present wall system;

FIG. 15 is a perspective view of one embodiment of a leveller mounting system as it slides into the channel of a lower glass wall extrusion and universal foot extrusion;

FIG. 16 is a side elevational view of the base trim connection to the leveller assembly;

FIG. 17 is a perspective, schematic view of the present wall system including integrated media panels and storage areas;

FIG. 18 is a perspective, schematic view of the present wall system incorporating an integrated media center;

FIG. 19 is a plan view of a two-way rectilinear connector for the present wall system;

FIG. 20 is a plan view of an alternative (radial) two-way connector for the present wall system;

FIG. 21 is a plan view of a three-way connector for the present wall system;

FIG. 22 is a plan view of a variance of a 90 degree connector for the present wall system;

FIG. 23 is a plan view of a 120 degree connector for three merging walls according to the present wall system;

FIG. 24 is a plan view of an end vertical and gasket for abutting existing walls with the present wall system;

FIG. 25 is a plan view of a connector for connecting to existing walls according to the present wall system;

FIG. 26 is a side elevational view of a floor leveller and ceiling connector for a solid (tile clad) wall;

FIG. 27 is a side elevational view of a floor leveller and ceiling connector for a glass wall;

FIG. 28 is a plan view of two wall panels having a gap between adjoining panels;

FIG. 29 is a plan view of two wall panels directly abutting each other and being sealed with a zipper;

FIG. 30 is a plan view of two wall panels directly abutting each other and having a zipper with no fins;

FIG. 31 is a plan view of an end vertical and gasket for abutting existing walls with the present glass wall system; and

FIG. 32 is a plan view of a connector for connecting to existing walls according to the present glass wall system.

DETAILED DESCRIPTION OF THE PREFERRED EMBODIMENTS

With reference to FIG. 1, the present invention is directed towards a wall system 10 made up of one or more modules 20. Each module comprises a pair of vertical end frames 12 that will be spaced apart by the desired width of each module. Modules 20 may be clad with tiles 18 and can be one or two sided with a finished wall surface on both sides

5

or a finished wall surface on one side only. Tiles **18** can be made of wood, plastic, metal fabric glass or other material, and end frames **12** may be interconnected by a plurality of horizontal stringers **8** that will be described in greater detail below.

With reference to FIG. 2, the next adjacent module **20** can be identical to its neighbour, or, as shown in this figure, may consist of two vertical end frames **17** and one or more dividers **14** which can be, for example, glass or plastic if transparency is desired. End frames **17** used for such dividers are shaped as shown most clearly in FIG. 4 and include a notch **19** that receives and holds the divider's vertical edge.

Stringers **8** are horizontally spaced apart at intervals along the height of the module for strength and rigidity. To support objects, cantilever channel stringers **40**, including a cantilever channel portion **41**, are used, as shown in FIGS. 8 and 9. Stringers **8** that do not include channel portion **41** can be used anywhere structure is required but the channel portion is not required for supporting objects. For example, the lowest stringer **8a** may not include cantilever channel portion **41**. The stringers are connected to end frames **12** by fasteners, usually threaded screws, in a manner to be described below.

If the module will be visible from both sides, finishing tiles **18** can be connected to the stringers on both sides of module **20**. It is not necessary that the tiles on one side of the wall be at all like the tiles on the other. They can be different materials or even aligned differently as shown in FIG. 1, in which the tiles on one side of the module are horizontally mounted and the tiles on the other side of the wall are vertically mounted for a different look. The tiles can also span adjacent modules, if required. For example, FIG. 1A depicts finishing tiles **18** spanning adjacent modules **20**. If only one side of the module will be visible, which can be the case for example if the module is used as a curtain wall to cover an existing wall, [its] it is necessary to apply tiles **18** to only one side of the module as needed.

The depth or thickness of the module can be selected by varying the width of frame **12**. For example, as will be described below, the modules can house a rear projection or digital video system and the greater depth is needed to enclose the componentry.

With reference to FIGS. 3, 4, 5 **28** and **29**, each end frame **12** and **17** includes a pair of rearwardly extending L-shaped flanges **23** that align vertically with correspondingly positioned and shaped flanges **23** on opposite end frame **12** or **17** so that frames **12** and **17** can be connected together by connecting strips ("zippers") **25**. If the adjacent module **20** itself comprises an end frame **12** as shown in FIGS. 28 and 29, flanges **23** will abut and will be connected together in the same manner using zippers **25**. As shown most clearly in FIG. 28, each of flanges **23** is formed with a bead **27**. Each zipper **25** is generally T-shaped in cross-sectional shape and includes a central spine **29** that fits between flanges **23** and a pair of arms **30** on opposite sides of the spine. Each arm includes a bead **31** that snap fits with beads **27** on flanges **23** for a secure but releasable connection. When two adjacent modules are connected together in this way, there is enough of a gap between them that the zippers can be accessed for removal, allowing an individual module to be removed should the need arise.

As illustrated in FIGS. 28 and 29, each zipper can also include a pair of flexible extended fins **32** extending rearwardly from the spine **29**. Depending on the application, a user may wish adjacent modules to be abutted together completely or to have a gap between them. In FIG. 28, a gap exists between the modules, and this gap is sealed using

6

extending fins **32**. As will be appreciated by those skilled in the art, the width of the gap is variable since extensions **32** are flexible and can accommodate various widths.

If no gap is desired, or if tiles span adjacent modules, FIG. 5 **29** illustrates an embodiment having adjacent panels. In this case extensions **32** are behind each panel, and the force of extensions **32** against the rearward side of the module creates an acoustic seal for the wall.

In an alternative embodiment illustrated in FIG. 30, it is also possible to have a zipper **25** without extensions **32**. This may be desirable when modules **20** abut and an acoustical seal is not required.

As such, in various embodiments, the zipper 25 may be positioned in a recessed location within the wall system 10. The recessed zipper 25 may allow for a single tile 18 to span multiple modules 20 without interference from the zipper 25. Additionally, a recessed zipper 25 may allow for the free movement of accessories 47 between adjacent wall modules 20 within a cantilever channel 41.

FIG. 5 shows an end piece **35** similar to end frame **17** but lacking notch **19**. This end piece is therefore used to finish the vertical edge of module **20** using zippers **25** if no additional module is to be connected to it.

If either of frames **12** or **17** is to start, or end, at an existing wall, flexible starter strips **37** can snap-fit onto flanges **23** as shown most clearly in FIG. 6. Starter strips **37** include curved flexible gaskets **38** which will conform to the shape of the existing wall and will provide sound and light barriers. This can also be seen in FIGS. 24 and 32.

Alternatively, as illustrated in FIGS. 25 and 31, a wall start **43** can be mounted to an existing wall to provide a start to a module. Wall start **43** is preferably an aluminum extrusion mounted vertically to an existing wall using known mounting techniques. The mounting technique of screws shown in FIG. 25 is not meant to be limiting.

Wall start **43** includes a flanges **23** and is connected to an end frame **12** or **17** using a zipper **25**. As indicated above, extensions **32** can provide a seal against the wall and panel.

To increase the height of an existing module **20**, or to combine a glass module above or below a tile-clad module, a spline **39** can be used to connect end frame **12** (or **17**) to an extension frame **12e** as shown most clearly in FIG. 7. Actually, as shown in this figure, extension frame **12e** is a length of frame **17**, which allows the lower portion of the wall to be hung with standard tiles and the upper extended portion of the wall to be finished in a glass or plastic divider **14** (within notch **19** of either frame **17**) for a combination of finished looks. The upper and lower extrusions **90** (comprising notch **92**, see also FIG. 15), which complete the framing of divider **14**, will be described below in connection with a levelling system in which the same extrusion is used.

It is desirable that work surfaces, mill work and wall accessories such as trays or document holders be connectable to modules **20**. This can be easily achieved in the present system by using cantilever channel stringers **40** with channel brackets horizontally disposed in the channel between adjacent tiles **18** as shown most clearly in FIGS. 8 and 9.

Each channel stringer **40** includes a central horizontally extending channel portion **41** with a generally L-shaped slot **42** formed along its length adapted to receive and engage a substantially L-shaped hook **45** formed on a wall accessory **47** such as the document holder shown in FIG. 8. A pair of diagonally extending webs **49** connects channel portion **41** to upper and lower portions **51** and **53** respectively. Each portion includes a tile support **55** that is the connection point for the tiles **18** that are mounted above and below channel

portion 41. More specifically, the upper and lower edges of tiles 18 are provided with a [connector strip 60] *tile clip* (connector strip 60) which is attached by means of screws, adhesive or any other suitable fastening to the rear surface of tile 18, as illustrated. Each connector strip 60 includes a pair of opposed flexible arms 62 to snap-fit with a [generally] protrusion (generally arrow shaped bead 64 formed along the edge of flanges [67]67) that [are] is formed on and [extend] extends the length of each upper and lower portion 51 and 53. This allows individual tiles 18 to be removed or replaced without having to disassemble the entire wall. The flanges 23 formed on vertical end frames 12 and 17 that are connected together by zippers 25 are located sufficiently inwardly that the zippers will not interfere with the continuity of slot 42 from one module to the next so that wall accessories, mill work or work surfaces can be connected or moved between modules without interference.

The upper and lower edges of tiles 18 that abut the channel portion 41 of each channel bracket are camphored for clearance as seen most clearly in FIG. 9.

The upper and lower portions 51 and 53 of the channel stringer 40 are advantageously formed with longitudinally extended circular recesses 57 and inner channels 58. Recesses 57 are adapted to receive screws used to connect end frames 12 or 17 to channel stringers 40. Channels 58 can be used to support mounting hardware for audio-video equipment mounted within the modules, cable management clips or any other hardware to be housed or contained in the module's interior. Channels 58 are also used to connect a single-sided tile clad module to brackets attached to existing wall surfaces.

With reference to FIG. 10, another embodiment of the invention is shown incorporating a section of standard slat wall 69 including slats 70 and slat wall channels 71 for connection to all slat wall accessories 47. Slat wall panels can make up some or all of the panels incorporated into any one module 20 and the modules themselves are configured for use with end frames 12 and zippers 25 so that the modules themselves can be connected together in any desired combination. Slat wall modules can be one (FIG. 11) or two sided (FIG. 10) for use as either dividing or curtain walls.

As shown in FIG. 12, in the applicant's related panel furniture system, a work surface or desktop 76 can be connected to modules 20. The desktop 76 can hook into either cantilevered channel stringers 40 or into slat wall channels 71 and otherwise the construction of the individual modules 20 is the same as described above for wall system 10. Furniture legs 80 shown in the example of FIG. 12 consist of a vertical frame 12 zipper connected to a finishing end extrusion 35 using zippers 25 as shown in FIG. 13, in the same manner as the wall system 10. The lower end of each furniture leg 80 is finished with a concentric sleeve 79 which conceals a threaded bolt 84 in the lower end of each leg which can be used for levelling.

As illustrated in FIG. 23, three vertical extrusions 2310 are connected to each other to create the connection point for the three wall systems, and each wall meets the others at an angle of 120 degrees.

In the case of modules having tiles that extend all the way down to the floor, applicant has developed a leveller mounting system that allows levellers to be placed anywhere along the length of a module and extra levellers to be added where needed. There are two variations of the leveller mounting system shown in FIGS. 15 and 16, one to be used with modules comprising tiles 18, and the other with modules using glass or plastic dividers.

Referring first to FIG. 15, this is the levelling system to be used with modules having glass or plastic dividers extending down to floor level. This system includes a structural extrusion 90, which is generally an inverted U-shaped channel with a notch 92 to engage the lower edge of the glass or plastic divider, and a universal foot 100.

Extrusion 90 and universal foot 100 are interconnected by means of dual threaded levellers 110, an example of which is shown in FIG. 14.

Leveller 110 has three distinct sections, an upper section 112, a middle section 115 and a lower section 120. Upper section 112 is cylindrical in shape and is internally left or right hand threaded. A plate 113 is connected to the section's upper end for a permanent connection thereto. Middle section 115 is both internally and externally threaded. The external threads will match the direction of the internal threads on upper section 112 while the internal threads will be in the opposite direction to match the external threading of lower portion 120. A fixed middle nut 114 is disposed at the lower end of middle section 115. Nut 114 can be used to turn middle section 115 relative to the upper and lower sections of the leveller.

As mentioned, the lower section 120 of the leveller is externally threaded and the threading will be in the opposite direction to the internal threading of upper section 112. In this way, each turn of nut 114 doubles the expansion or contraction of the leveller to halve the levelling time. The lower end of section 120 includes its own fixed adjustment nut 124 and an inverted V-shaped lower plate 125.

FIG. 15 shows how leveller 110 is installed. Plate 113 aligns with channels 94 in extrusion 90 to be slidable along the length of the channel to any desired location. The V-shaped lower plate 125 aligns with and slides into grooves 101 in foot 100. Those levellers that fit at the end of a foot are slightly modified to include tabs 126 at the outer corners of plate 125 which prevent the plate from moving inwardly. When vertical end frames 12 or 17 are attached to extrusion 90, plate 113 is prevented from moving outwardly so that the leveller is held in its position at the very end of foot 100. Frames 12 or 17 are connected to extrusion 90 by means of screws that thread into one or more of circular slots 117 in the extrusion.

If modules 20 are situated atop carpet, toothed carpet grippers 130 are inserted into slots 129 in foot 100. If the modules are installed on hard surfaces, nonskid grippers can be inserted instead. The grippers can be placed precisely where needed to bear the modules weight and can be easily moved, replaced or switched over as needed.

FIG. 16 shows a leveller 110 installed on modules 20 and illustrates the installation of base trim 140 used to conceal the levellers 110 when they're not being adjusted. In this view, plate 113 is again slidingly received into channels formed in the module's lowermost extrusion and plate 125 is received into grooves 101 in foot 100. The base trim 140 includes baseboards 142 and snap pieces 144. Snap pieces 144 snap-fit onto foot 100 as shown with grooves 145 and 147 on the snap piece engaging flanges 108 and 109 on the foot. Each snap piece includes a longitudinally extending elevated hook 149 and a similarly longitudinally extending channel 150. Each baseboard includes a hook 143 to engage hook 149 on the snap piece, and a bead 153 that snap fits into channel 150 to retain the baseboards in a vertical position to provide a finished look. Because the baseboards are installed usually after the modules have been assembled together, the boards can span multiple modules for longer runs and fewer seams.

Reference is now made to FIGS. 26 and 27. As illustrated, besides the bottom connection with the leveller (as described with relation to FIGS. 15 and 16 above), a ceiling connection is also preferred.

FIG. 26 shows a ceiling connection for a solid wall, such as those described above having tile cladding. A ceiling track 2601 is affixed to the ceiling above the area for the desired wall. Each module includes two horizontal uppers 2610 abut thereto (on either side of the ceiling track), the horizontal upper including an upper flange 2612. A ceiling trim 2614 is affixed to upper flange 2612. Ceiling trim 2614 is flexible and allows variable spacing of the wall with the ceiling. Specifically, the trim 2614 will flex to allow the wall to move closer or further from the wall as required based on levelling needs.

Horizontal upper 2610 further includes a *protrusion* (bead 64) as described above to attach a tile (*via the flexible arms of the illustrated tile clips*) to the horizontal upper. Further, recesses 2616 are used to attach horizontal uppers to frames 12 or 17.

To affix a wall, an installer can first install ceiling track 2601 in the correct location. The wall is then created with levellers 110 in a lowermost position. The levellers 110 are then extended to level the wall and to further cause horizontal uppers 2610 to abut ceiling track 2601 on either side of ceiling track 2601, as illustrated in FIG. 26.

Alternatively, if a divider such as a glass panel is being used, a one piece upper 2701 can be used, as illustrated in FIG. 27. The one piece upper 2701 comprises a flange 2712 to connect a ceiling trim 2714 to. Ceiling trim 2714 is preferably the same as ceiling trim 2614. Upper 2701 further includes a channel 2716 for receiving a divider.

The present wall system 10 includes curved walls using curved aluminum stringers and extrusions and curved tiles 18. In conventional systems, curved walls are constructed of faceted panels rather than true, radii arcs. A curved wall is illustrated in FIG. 19.

With reference to FIG. 17, a module 20 is shown in which a couple of tiles 18 have been replaced with an integrated media panel 190. The panel can be a Fresnel lens, a plasma screen, an LCD screen or a digital whiteboard. Rear projection technology can be used to project images onto the Fresnel lens, or the digital whiteboard technology allows sketching, writing, layout or computer screen emulation. In the example shown, adjacent tiles 18 incorporate speakers 192 to provide sound. Tile 18 surrounding the screen area can be used for integrated storage areas.

With reference to FIG. 18, there is shown schematically a module 20 with an integrated media center 200 suspended therein.

Various connectors are also provided to allow the present reconfigurable wall system to form corners. Reference is now made to FIGS. 19, 20, 21 and 22.

FIG. 19 illustrates a two-way rectilinear connector 1910. Connector 1910 includes a finished outer surface on sides 1912 and 1914. Further, flanges 23 are provided on sides 1916 and 1918. Flanges 23 can be used with zipper 25 to connect to end frames 12 or 17. An extension 1920 extends between sides 1916 and 1918 to form a finished corner once modules 20 are connected to these sides. Further, sides 1912 and 1914 include an elongate end 1922 for hiding zipper 25 and creating a finished surface.

FIG. 20 is similar to FIG. 19, with the principle difference being the radial finished outer surface 2012 replacing sides 1912 and 1914. Otherwise similar reference numerals are used between FIGS. 19 and 20.

FIG. 21 illustrates a three way connector for a "T" connection. Three modules 20 are connected to connector 2101. Connector 2101 includes a finished outer surface 2112. Flanges 23 are used to connect modules 20. Extensions 1920 provide a finished look between adjacent modules 20. Further, elongate end 1922 provides a finished look on the outside of the wall.

FIG. 22 illustrates an alternative 90 degree connector. In this case, an extrusion 2201 is affixed to the end of a module 20. Two extrusions are connected using a connector 2312. Since connector 2312 is flexible, an angle greater than or less than 90 degrees is possible. In a preferred embodiment, the swing on the connector is approximately 15 degrees.

The above-described embodiments of the present invention are meant to be illustrative of preferred embodiments and are not intended to limit the scope of the present invention. Various modifications, which would be readily apparent to one skilled in the art, are intended to be within the scope of the present invention. The only limitations to the scope of the present invention are set forth in the following claims appended hereto.

What is claimed is:

1. A movable reconfigurable wall system comprising:
 - a) at least one wall module having a front and rear surface and top, bottom, right side and left side edges, said at least one wall module having:
 - i) a vertical end frame disposed adjacent to each of said right and left side edges, each vertical end frame having a first vertically extending flange and a spaced apart second vertically extending flange thereon, each of said first vertically extending flange and said second vertically extending flange having a beaded portion, the beaded portion on one of said first vertically extending flange or said second vertically extending flange extending toward the front surface of the wall module and the beaded portion on the other of said first vertically extending flange or said second vertically extending flange extending toward the rear surface of the wall module;
 - ii) a plurality of horizontal stringers affixed between said vertical end frames at said right and left side edges; and
 - iii) an aesthetic surface affixed to said stringers; and
 - b) a removable connecting strip having a pair of spaced apart flexible arms, each arm having a beaded portion thereon, the beaded portion of one of said arms being adapted to connect releasably to the beaded portion of one of said first vertically extending flange or said second vertically extending flange on said vertical end frame and the beaded portion of the other of said arms being adapted to connect releasably to the beaded portion of a corresponding opposed vertically extending flange on a separate vertical end frame of a second wall module, a wall bracket, a finishing trim or a connection post to hold one of said first vertically extending flange or said second vertically extending flange and said opposed vertically extending flange together, the beaded portions of said first vertically extending flange or said second vertically extending flange and said opposed vertically extending flange fitting inside the arms of said connecting strip to hold said first vertically extending flange or said second vertically extending flange and said opposed vertically extending flange together thereby releasably connecting said at least one wall module to the other of said second wall module, wall bracket, finishing trim or connection post.]

11

[2. The movable reconfigurable wall system of claim 1, wherein said connecting strip includes a spine adapted to fit between said first vertically extending flange or said second vertically extending flange and said opposed vertically extending flange.]

[3. The movable reconfigurable wall system of claim 2, wherein said connecting strip further includes a pair of flexible fin extensions extending opposite to said flexible arms for providing a seal.]

[4. The movable reconfigurable wall system of claim 1, wherein said aesthetic surface includes a tile panel on said front surface, said rear surface, or both said front surface and said rear surface.]

[5. The movable reconfigurable wall system of claim 4, wherein each said stringer includes one or more protrusions, said reconfigurable wall system further including tile clips for affixing tiles to said one or more protrusions.]

[6. The movable reconfigurable wall system of claim 1, wherein said aesthetic surface is a single divider selected from a group consisting of substrates consisting of glass, plastic, or wood and metal.]

[7. The movable reconfigurable wall system of claim 6, wherein said stringers and end frames include a channel for receiving said divider.]

[8. The movable reconfigurable wall system of claim 1, wherein said stringers include a cantilever channel stringer, said cantilever channel stringer having: a central horizontally extending channel portion with a generally L-shaped slot, said L-shaped slot adapted to receive and engage a substantially L-shaped hook formed on a wall accessory; an upper portion having a tile support; a lower portion having a tile support; and a pair of extending webs connecting said channel portion to said upper and a lower portion.]

[9. The movable reconfigurable wall system of claim 1, wherein said system further comprises an extension frame, said extension frame including a pair of vertical extension end frames and at least one stringer, said extension frame being affixed atop of said at least one module with a spline on each end of said end frame.]

[10. The movable reconfigurable wall system of claim 1, wherein said aesthetic surface includes a slat wall, said slat wall having slats and slat wall channels for connection to slat wall accessories.]

[11. The movable reconfigurable wall system of claim 1, said system further comprising a levelling system having: a universal foot; a leveller capable of engaging said universal foot; and a structural extrusion to engage surface of said at least one module, said structural extrusion connecting to said leveller, wherein said leveller provides the sole connection between said universal foot and said module.]

[12. The movable reconfigurable wall system of claim 11, wherein said leveller comprises: a cylindrical internally threaded upper section; an internally and externally threaded middle section, said external threads matching said internally threaded upper section; and an externally threaded lower section, said externally threaded lower section matching internal threads of said middle section, wherein said middle section can be twisted to extend or contract said leveller.]

[13. The movable reconfigurable wall unit of claim 11 further comprising a base trim, said base trim attaching to said universal foot.]

[14. The movable reconfigurable wall unit of claim 1 further comprising a ceiling connection, said ceiling connection including: a ceiling track affixed to a ceiling; a horizontal upper section affixed to said module, said horizontal upper section adapted to fit about said ceiling track;

12

a flexible gasket affixed to said horizontal upper section and extending above said horizontal upper section to contact the ceiling.]

[15. The movable reconfigurable wall unit of claim 1, wherein said wall bracket comprises:

an extrusion for connection to an existing wall in alignment with said end frame; and

first and second flanges on said extrusion corresponding to said first vertically extending flange and said second vertically extending flange on said end frame and arranged in opposition thereto.]

[16. The movable reconfigurable wall unit of claim 1 further comprising a wall joint, said wall joint comprising a flexible gasket and a channel, said channel adapted to connect to a flange of said at least one module.]

[17. The movable reconfigurable wall unit of claim 1, wherein said at least one module includes curved stringers and curved aesthetic surfaces.]

[18. The movable reconfigurable wall unit of claim 1, wherein said connection post includes at least two sides having vertically extending flanges thereon corresponding to and arranged in opposition to said first and second flanges on said end frame.]

[19. The movable reconfigurable wall unit of claim 1, wherein said aesthetic surface includes a multimedia component.]

[20. The movable reconfigurable wall unit of claim 19, wherein said multimedia component is a video monitor.]

[21. The movable reconfigurable wall unit of claim 1, wherein said vertical end frame depth is extended to provide a deeper wall.]

[22. The movable reconfigurable wall unit of claim 21, wherein said deeper wall is adapted to accommodate a rear-projection video system.]

[23. The movable reconfigurable wall unit of claim 21, wherein said deeper wall is adapted to accommodate an integrated storage system.]

[24. The movable reconfigurable wall unit of claim 1, further comprising a wall mounted module for mounting to an existing wall face, said wall mounted module having:

a) vertical end brackets disposed at least at its side edges, each said vertical end frame having a vertically extending flange directed away from said existing wall face;

b) a plurality of horizontal stringers affixed between said pair of vertical end brackets; and c) an aesthetic surface affixed to said stringers.]

[25. The movable reconfigurable wall unit of claim 1, further comprising a furniture system connectable to said at least one module, the furniture system having: a work surface, said work surface connectable to said stringers; and furniture legs, said furniture legs connecting to said work surface at a first end and connecting to a threaded bolt at a second end opposite said first end, said threaded bolt allowing levelling of said work surface.]

26. A reconfigurable wall system comprising:

a plurality of wall modules, each wall module being connectable to one or more other wall modules;

at least one wall module of the plurality of wall modules having front and rear surfaces and top, bottom, right side, and left side edges, the at least one wall module being configured to support and have coupled to at least one of the front and rear surfaces thereof one or more wall tiles;

at least another wall module of the plurality of wall modules having a front edge and a rear edge defined by opposing, visible outer surfaces of first and second vertical end frames, a top side edge, a bottom side

13

- edge, a right side edge, and a left side edge, the at least another wall module comprising a divider between the front edge and the rear edge;
- wherein:
- the at least another wall module is selectively connectable to the at least one wall module such that the at least another wall module is positioned above or below the at least one wall module, and
 - the at least another wall module comprises a pair of spaced apart end frames, each end frame having a notch formed therein, wherein the divider is received and held within the notches; and
- a leveling system having:
- a foot;
 - a leveler engaging and supported by said foot and engaging and supporting a horizontal member a lowermost module of the at least one or at least another wall module;
- wherein said leveler
- (a) has a height that is capable of being adjusted and
 - (b) has a horizontal location that was established by sliding said leveler horizontally relative to, and while engaging said horizontal member and/or said foot.
27. The system as recited in claim 26, wherein the at least one wall module comprises a pair of spaced apart vertical end frames.
28. The system as recited in claim 27, wherein the pair of spaced apart vertical end frames are connected to one another by a plurality of stringers.
29. The system as recited in claim 28, wherein the plurality of stringers are configured to have the one or more wall tiles coupled thereto.
30. The system as recited in claim 26, wherein the top edge of the at least one wall module and the bottom edge of the at least another wall module are configured to enable the at least another wall module to be connected on top of the at least one wall module.
31. The system as recited in claim 26, wherein the top edge of the at least another wall module and the bottom edge of the at least one wall module are configured to enable the at least one wall module to be connected on top of the at least another wall module.
32. The system as recited in claim 26, wherein the at least one wall module and the at least another wall module each comprise a pair of spaced apart vertical end frames.
33. The system as recited in claim 32, wherein a vertical end frame of the at least one wall module is connectable to a vertical end frame of the at least another wall module to connect together the at least one wall module and the at least another wall module.
34. The system as recited in claim 33, wherein the vertical end frame of the at least one wall module is connectable to the vertical end frame of the at least another wall module with a spline.
35. The system as recited in claim 26, further comprising one or more wall tiles coupled to the at least one wall module.
36. The system as recited in claim 35, wherein the one or more wall tiles comprise wood, metal, fabric, or glass.
37. The system as recited in claim 26, further comprising another divider coupled to the at least another wall module.
38. The system as recited in claim 37, wherein each divider comprises glass or plastic.
39. The system as recited in claim 37, wherein each divider is transparent.

14

40. The system as recited in claim 37, wherein at least one of the dividers is held into place at least in part by a continuous notch in the bottom side edge that extends from the left side edge to the right side edge.
41. The system as recited in claim 26, wherein the at least one wall module and the at least another wall module have substantially equal widths.
42. A reconfigurable wall system comprising:
- a first wall module comprising first and second tiles coupled to a stringer interconnecting one or more first vertical end frames to another of the one or more first vertical end frames, wherein the stringer comprises a continuous channel extending the length of the stringer; and
 - a second wall module comprising a first divider coupled to one or more second vertical end frames between a first front edge and a first rear edge of the first wall module, wherein the first wall module and the second wall module are selectively connectable to one another such that the second wall module may be positioned above or below the first wall module to selectively adjust the height of a reconfigurable wall;
- wherein the continuous channel is configured to receive a wall accessory via a receiving feature;
- wherein:
- the continuous channel is accessible from outside of the first and second tiles;
 - the receiving feature comprises a first edge that aligns with an edge of the first tile and a second edge that aligns with an edge of the second tile.
43. The system as recited in claim 42, wherein the first and second tiles are connected to the one or more first vertical end frames by one or more stringers.
44. The system as recited in claim 43, wherein the one or more first vertical end frames comprise two spaced apart vertical end frames.
45. The system as recited in claim 44, wherein a plurality of stringers are coupled between the two spaced apart vertical end frames.
46. The system as recited in claim 42, wherein each of the one or more second vertical end frames comprises a notch configured to receive and hold the divider therein.
47. The system as recited in claim 42, wherein the second wall module further comprises one or more horizontal frame elements connected to the one or more second vertical end frames.
48. The system as recited in claim 47, wherein at least one of the one or more horizontal frame elements comprises a notch configured to receive and hold the divider therein.
49. The system as recited in claim 42, wherein at least one of the one or more first vertical end frames and at least one of the one or more second vertical end frames are configured to be secured together to connect the first wall module to the second wall module.
50. The system as recited in claim 49, wherein the at least one of the one or more first vertical end frames and the at least one of the one or more second vertical end frames are configured to be secured together with a spline.
51. The system as recited in claim 42, wherein the one or more tiles comprise wood, metal, fabric, or glass.
52. The system as recited in claim 42, wherein the divider comprises glass or plastic.
53. The system as recited in claim 42, wherein the divider is transparent.
54. The system as recited in claim 42, wherein at least one of the first wall module and the second wall module is

15

configured to be connected along a left or right vertical edge thereof to a vertical edge of a third wall module.

55. A reconfigurable wall system comprising:

a first wall module having a pair of spaced apart first vertical end frames, one or more stringers extending between and connected to the first vertical end frames, and one or more tiles connected to the one or more stringers on at least one of a front surface and a rear surface of the first wall module; and

a second wall module having a pair of spaced apart second vertical end frames, top and bottom horizontal frame elements extending between and connected to the second vertical end frames, and a divider mounted between the second vertical end frames and the top and bottom horizontal frame elements such that the divider is disposed between a front edge and a rear edge of the first wall module;

wherein:

the first wall module and the second wall module are selectively connectable to one another such that the second wall module may be positioned above or below the first wall module to selectively adjust the height of a reconfigurable wall formed, at least in part, by the first and second wall modules, and a bottom edge of the divider is inset into the bottom horizontal frame element; and

16

a leveling system having:

a foot having one or more grooves formed therein, the foot providing an upwardly curved surface; and

a leveler engaging and supported by said foot, said leveler horizontally engaging and supporting a horizontal member of said lowermost of the first or second wall modules, wherein said leveler

(a) has a height that is capable of being adjusted and
(b) has a non-planar base that rests upon the upwardly curved surface of said foot.

56. The system as recited in claim 55, wherein the divider is transparent.

57. The system as recited in claim 55, wherein at least one of the second vertical end frames comprises a notch configured to receive and hold an edge of the divider.

58. The system as recited in claim 55, wherein at least one of the top and bottom horizontal frame elements comprises a continuous notch extending a length of the frame element configured to receive and hold an edge of the divider.

59. The system as recited in claim 55, wherein the first wall module and the second wall module are configured to be connected together with a spline.

60. The system as recited in claim 55, wherein at least one of the first wall module and the second wall module is configured to be connected along a left or right vertical edge thereof to a vertical edge of a third wall module.

* * * * *