

(No Model.)

C. L. HYDE.

CONSTRUCTION OF EMERY WHEELS AND SUPPORTS THEREFOR.

No. 489,149.

Patented Jan. 3, 1893.

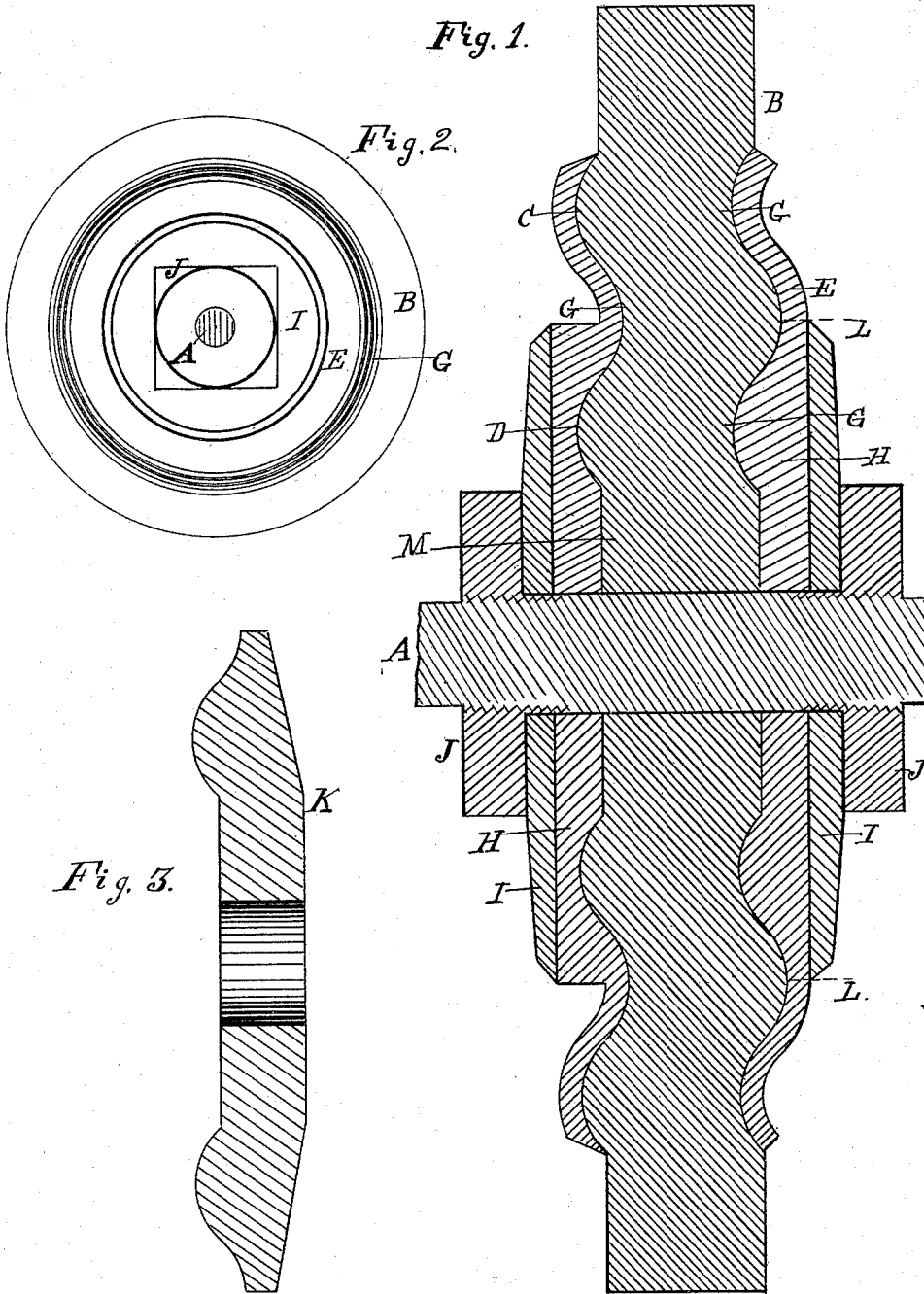

Witnesses:  
M. E. Lawrence.  
W. W. Kimball.

Inventor.  
Clarence L. Hyde.  
By L. L. Chapin, atty.

# UNITED STATES PATENT OFFICE.

CLARENCE L. HYDE, OF CHICAGO, ILLINOIS.

## CONSTRUCTION OF EMERY-WHEELS AND SUPPORTS THEREFOR.

SPECIFICATION forming part of Letters Patent No. 489,149, dated January 3, 1893.

Application filed February 29, 1892. Serial No. 423,295. (No model.)

*To all whom it may concern:*

Be it known that I, CLARENCE L. HYDE, a citizen of the United States, residing at Chicago, county of Cook, and State of Illinois, have invented new and useful Improvements in the Construction of Emery-Wheels and Supports Therefor, of which the following is a specification, reference being had to the annexed drawings, illustrating the invention, in which—

Figure 1 is vertical central section of an emery wheel constructed and supported in accordance with my invention. Fig. 2. an elevation of Fig. 1 on a scale of about one third the size thereof. Fig. 3. a modification of the devices for supporting the emery wheel.

This invention relates to the construction of an emery wheel so that, the thickness of the wheel shall be substantially the same in all the grinding surface it presents, as it wears to a less diameter; and at the same time the wheel shall possess such a serpentine form in radial section that the means employed to prevent the wheel from bursting by centrifugal force can be properly applied. To that end, M. B. represent those portions of the wheel which form a plane parallel to itself, M being the hub portion and B that portion which extends beyond the corrugated disks H whose internal contour coincides with the serpentine and flat portion of the sides of the wheel they cover. In forming the wheel of the size shown one side will have thereon two convex curves C and D and one concave curve G. and the other side will have one convex curve L and two concave curves G and G', and the curves of the supports H, H. will be respectively inverse to the curves on the wheel; but for larger wheels there may be additional serpentine curves formed in its side portions and the supports may be extended.

A is the shaft of the wheel and I, I. are two collar plates which lie between the nuts J, J. to insure material strength where the emery wheel is quite thick and is to be run at a high

rate of speed, but in ordinary wheels, as speeded, the supports H, H. will serve well the purpose, if made much lighter than the drawings represent.

In practice the emery wheels may be molded and the serpentine portions trued on a lathe when the composition of the wheel is yet soft enough to be worked in that manner. Sometimes I form the wheels in dies to attain accuracy in contour. The supports H. H may be made of cast metal properly trued up to fit; preferably, however, I form them of suitable metal and by dies. Care must be taken to make the supporting disk fit, closely, the serpentine contour of the emery wheel; and the outer margin of the disk on both sides of the wheel comes first in contact with the latter that the exterior portion of the wheel be so clamped between the supports that they will sustain the centrifugal force exerted by the wheel. As the wheel becomes worn down, the supports H. H. I. I. can be removed and replaced by supports of a less diameter, one of which is shown in section at K Fig. 3, which will extend only to between L. L. Fig. 1.

In practice the left hand nut J is often simply a collar shrunk on the shaft; but it is sometimes desirable to employ it as a jamb nut.

Having thus described my invention I claim and desire to secure by Letters Patent—

An emery wheel having its sides formed with concave portions C and convex portions G, the convexities on one side being opposite the concavities on the other side, whereby the wheel is made of substantially uniform thickness throughout, and disks having one of their sides provided with corresponding convex and concave portions clamped to the sides of the wheel, as described and shown.

CLARENCE L. HYDE.

Witnesses:

G. L. CHAPIN,  
ELLIS S. CHESBROUGH.