



US 20120302354A1

(19) **United States**

(12) **Patent Application Publication**
Thakkar et al.

(10) **Pub. No.: US 2012/0302354 A1**

(43) **Pub. Date: Nov. 29, 2012**

(54) **ONLINE ASYNCHRONOUS GAME WITH
PLAYER-MATCHING MECHANIC BASED ON
GAMEPLAY CHARACTERISTICS**

Publication Classification

(51) **Int. Cl.**
A63F 9/24 (2006.01)

(76) Inventors: **Vijay Thakkar, (US); Michael
McGary, (US); Kevin Holme,
(US); Justin Rouse, (US)**

(52) **U.S. Cl. 463/42**

(21) Appl. No.: **13/244,921**

(57) **ABSTRACT**

(22) Filed: **Sep. 26, 2011**

A player-matching mechanic selects users for an online asynchronous game where players specify moves at different times. Values from instances of the game are used to determine characteristics of the users including at least one of gameplay characteristics or chat characteristics. Users can be chosen for instances of the game by comparing values corresponding to these characteristics.

Related U.S. Application Data

(63) Continuation of application No. 13/114,900, filed on May 24, 2011.

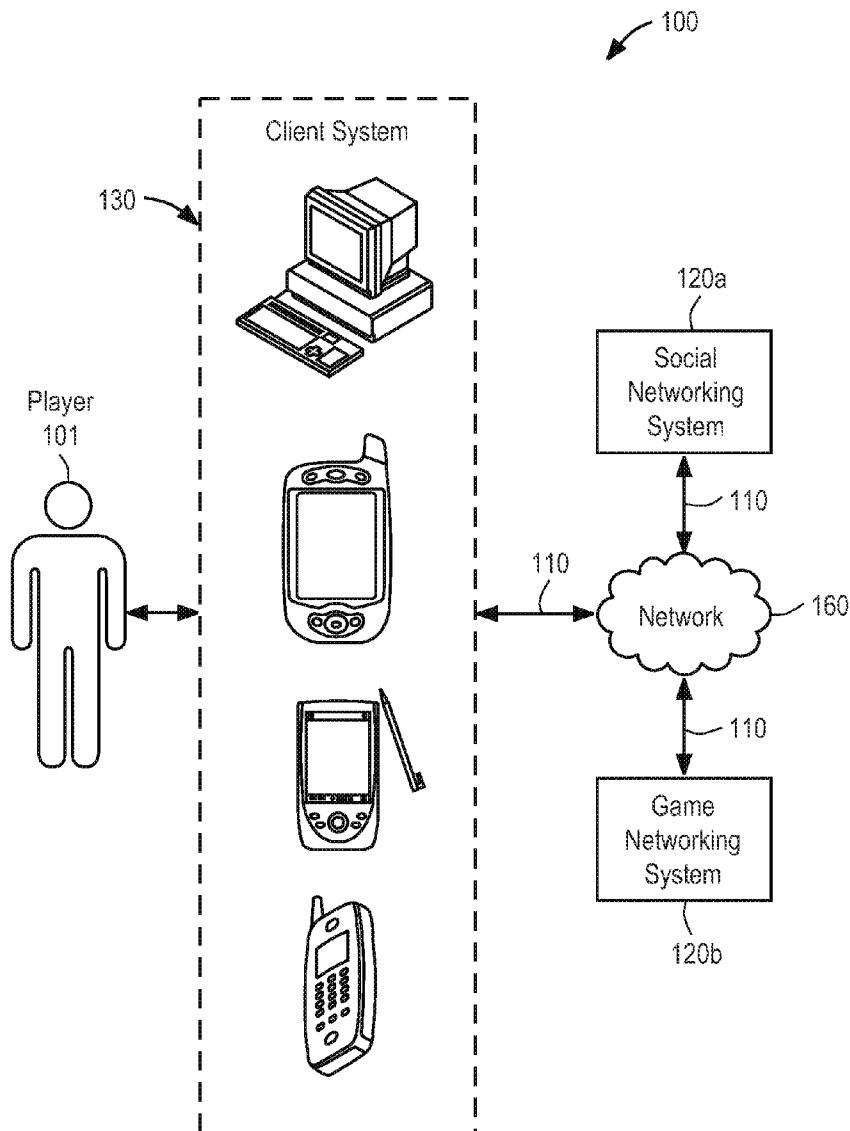

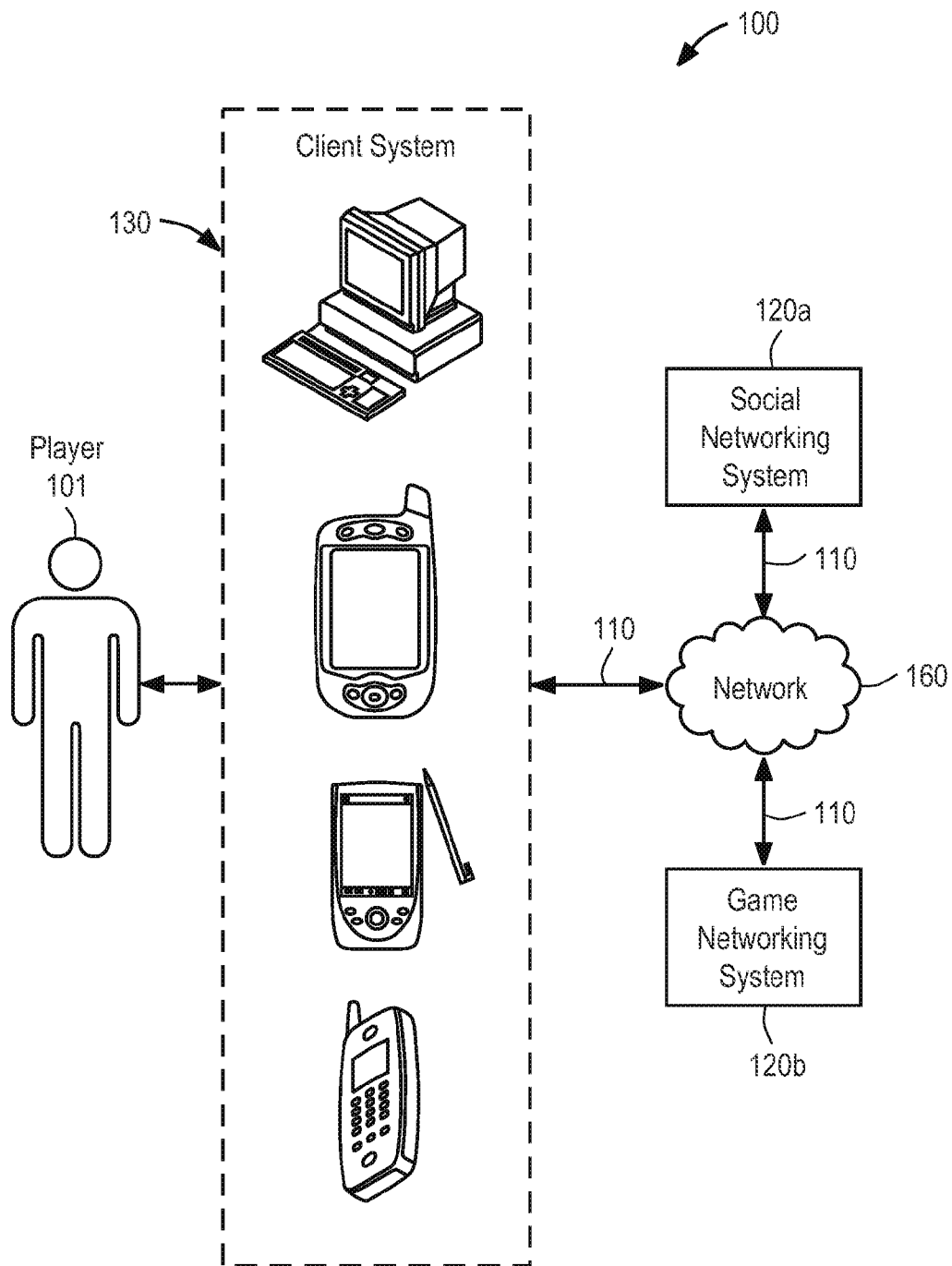

FIG. 1

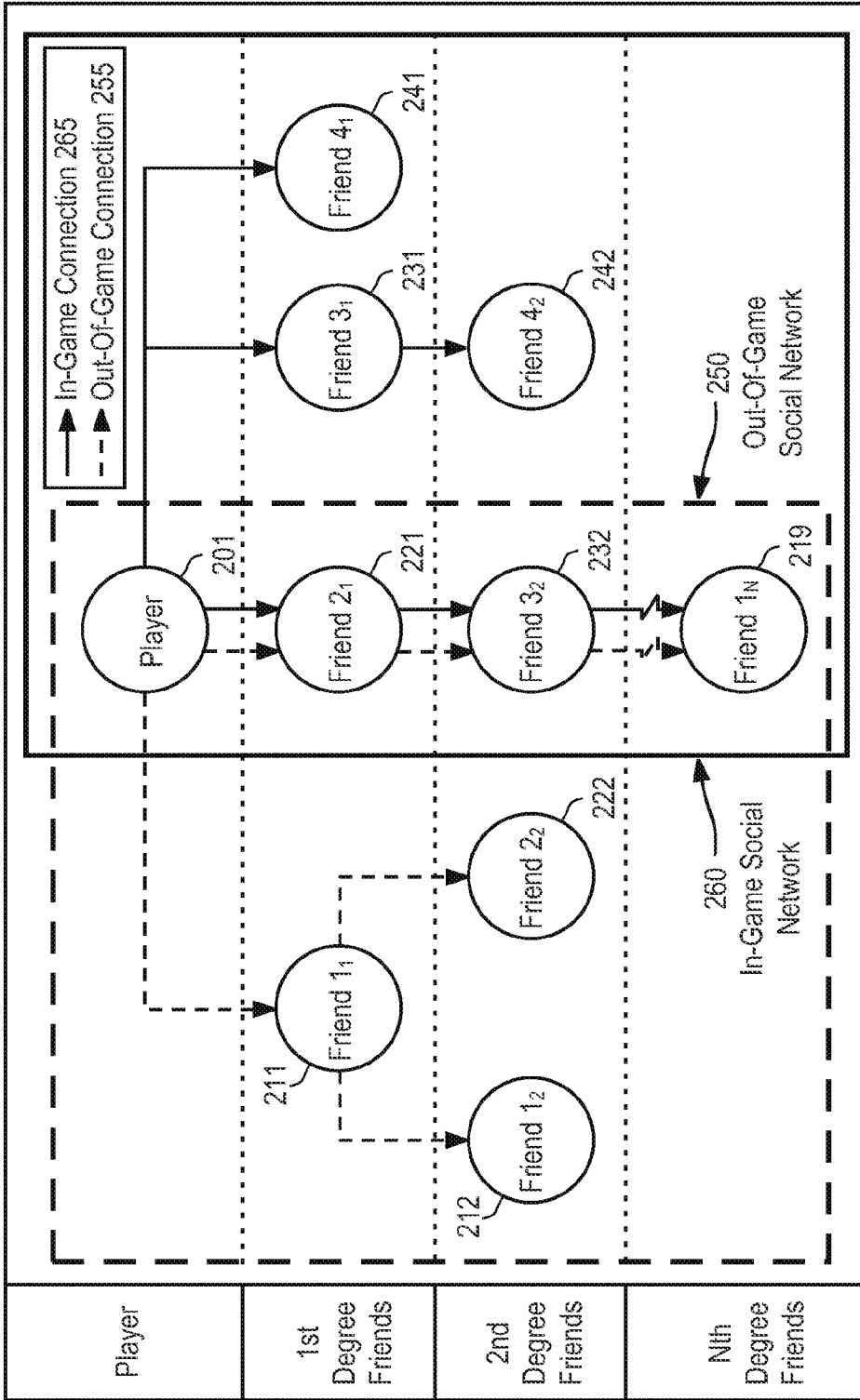

FIG. 2

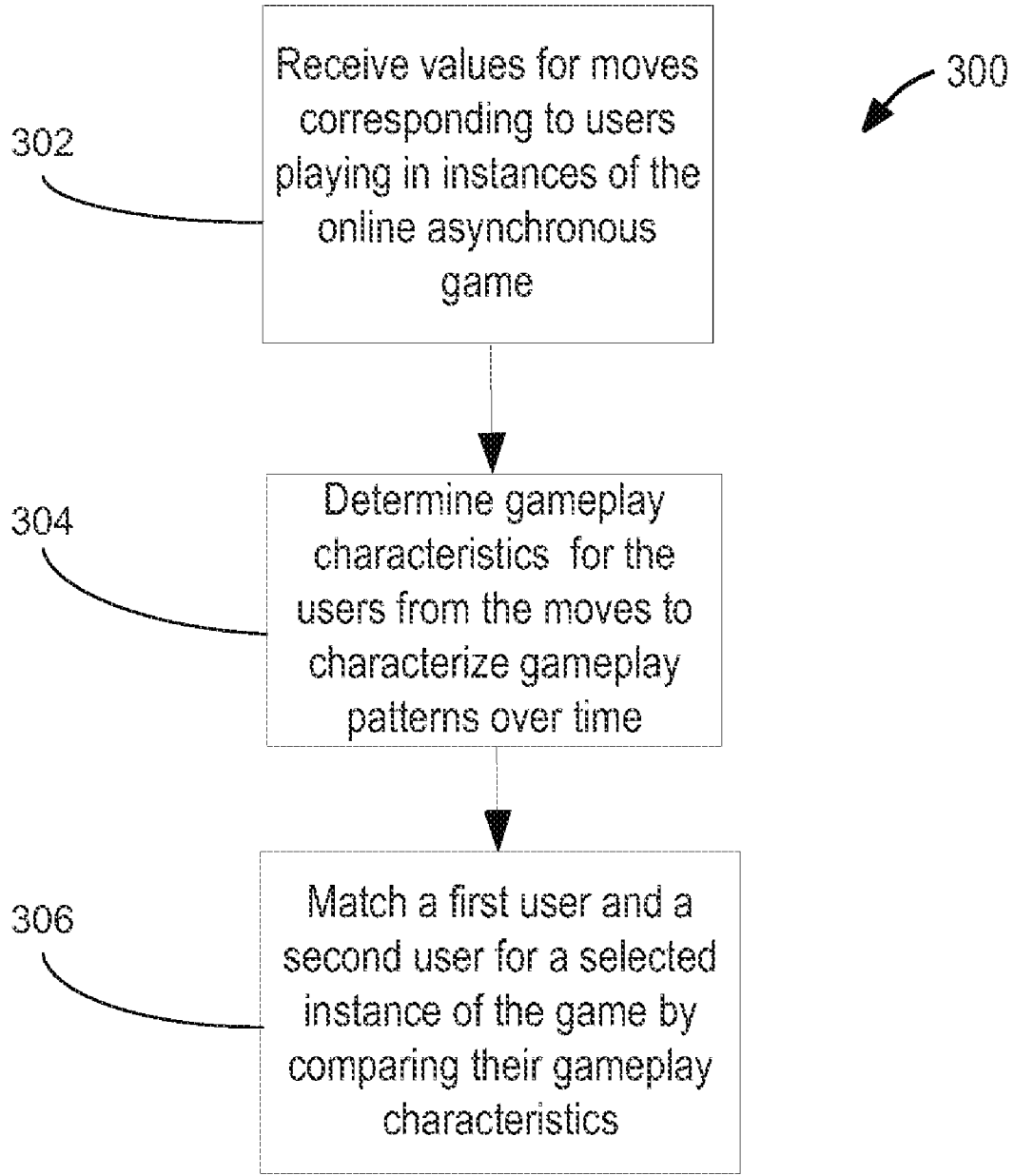

FIG. 3

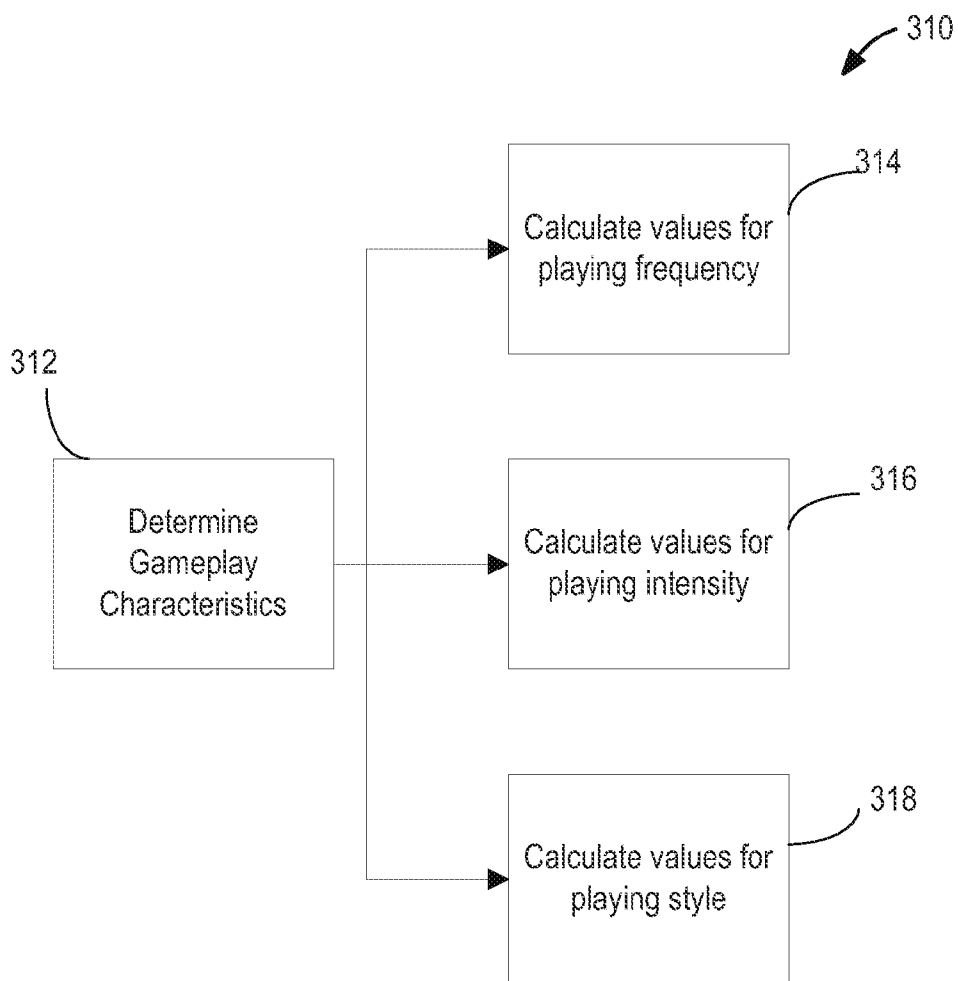

FIG. 4

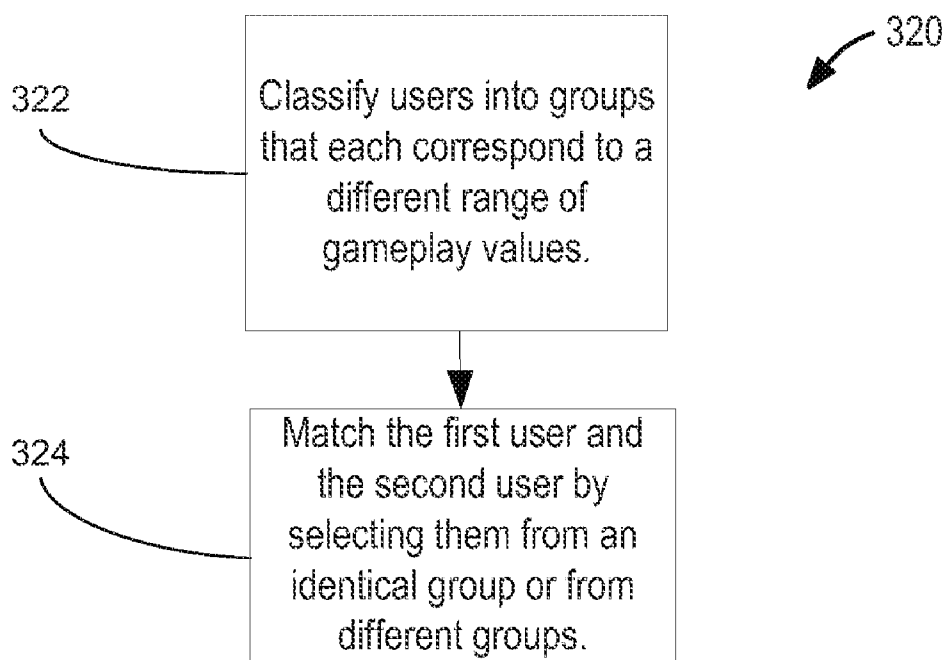

FIG. 5

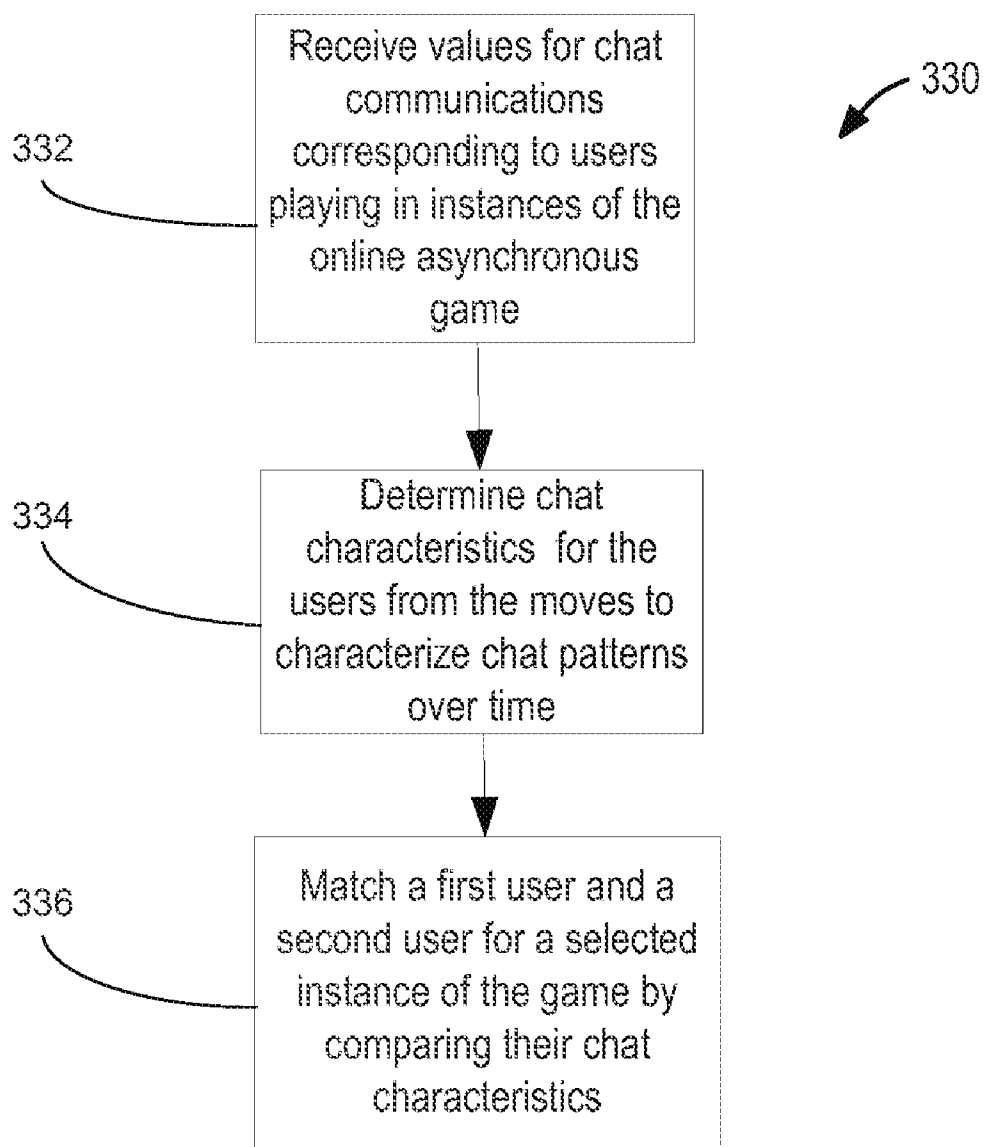

FIG. 6

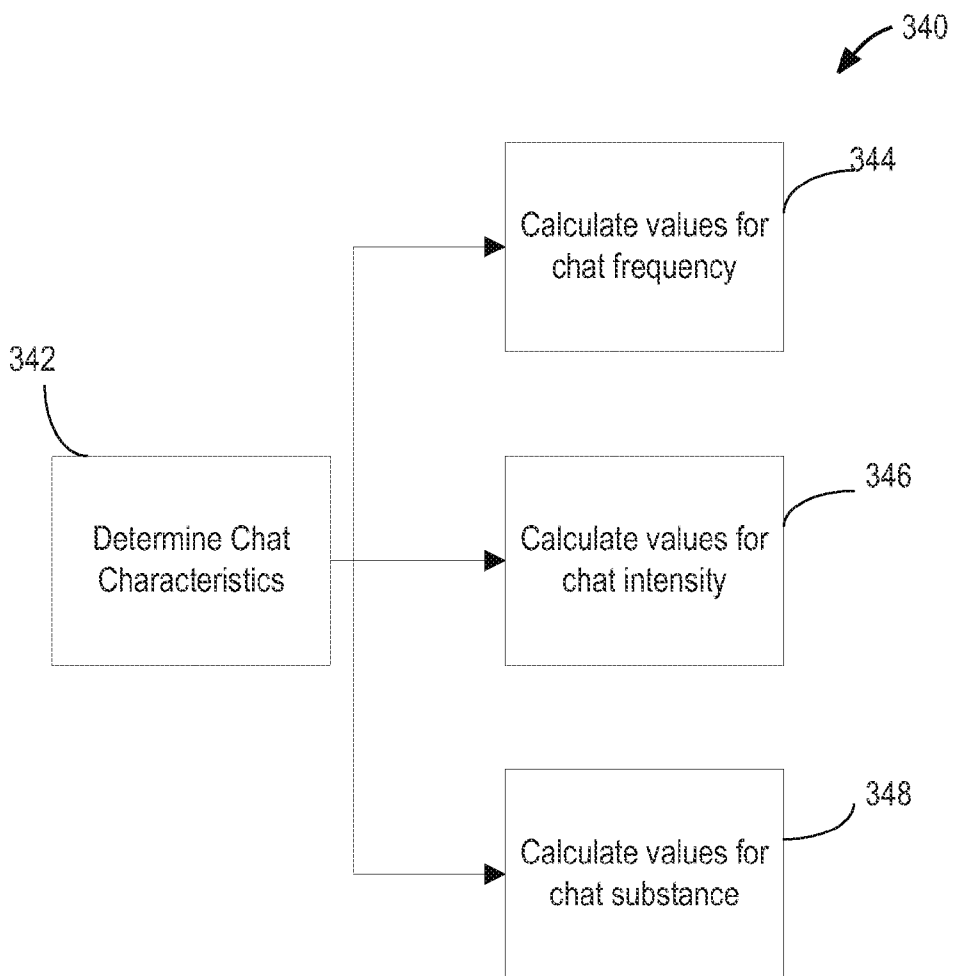

FIG. 7

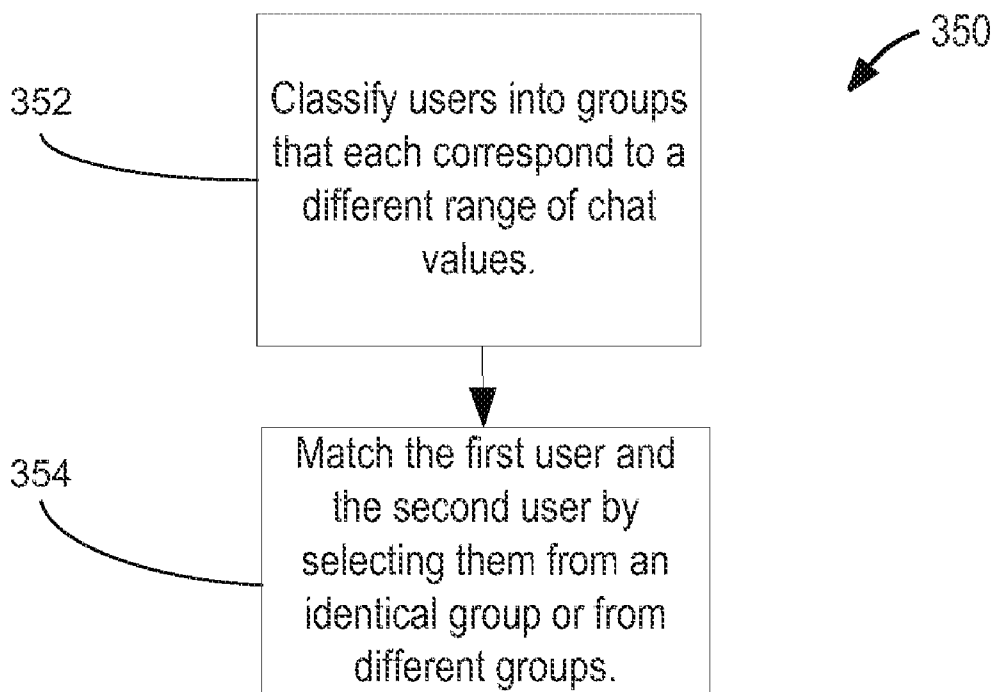

FIG. 8

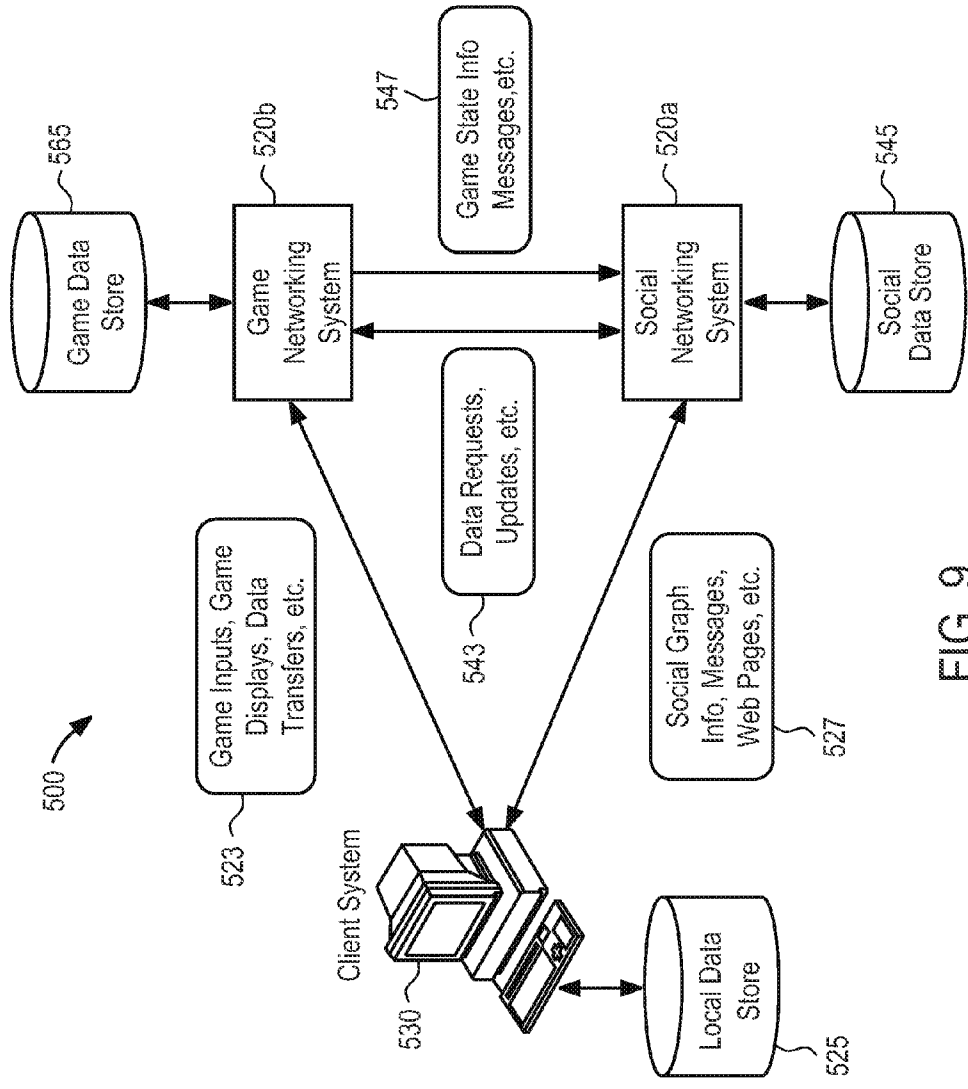

FIG. 9

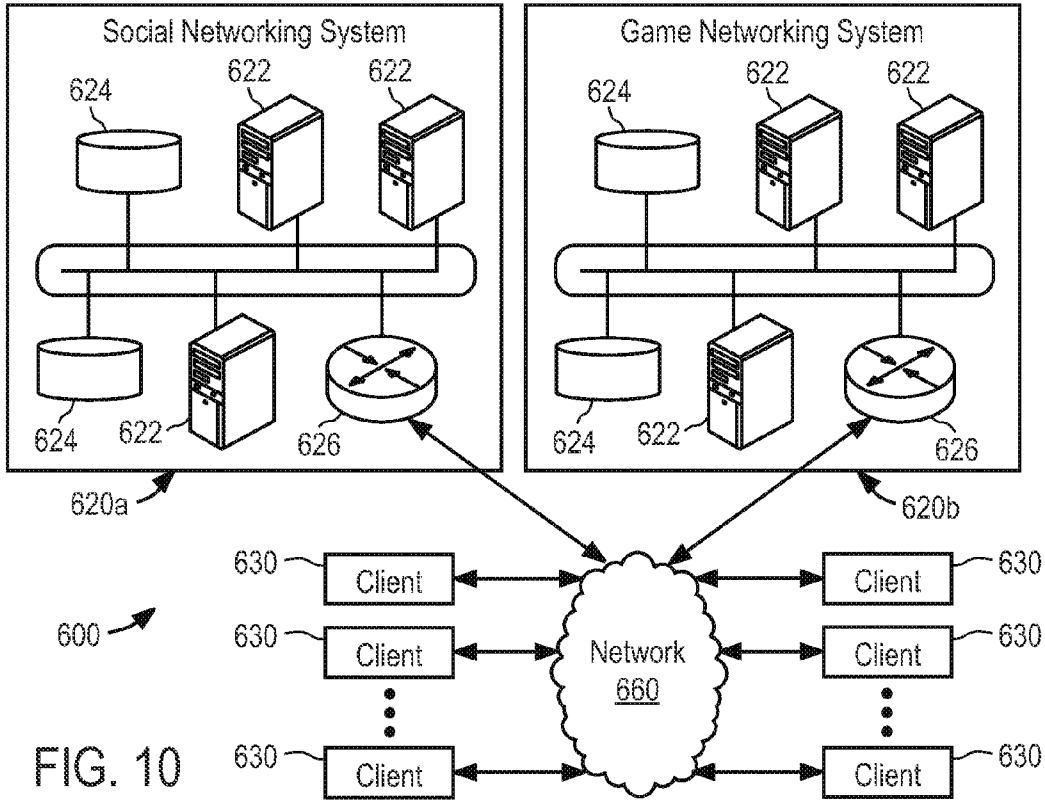

FIG. 10

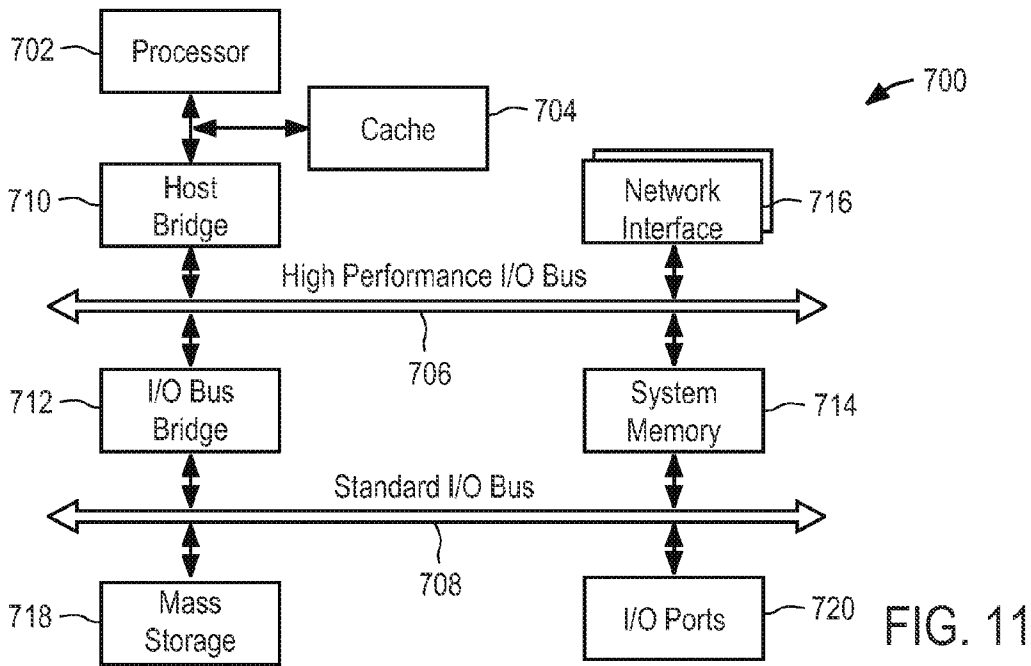

FIG. 11

**ONLINE ASYNCHRONOUS GAME WITH
PLAYER-MATCHING MECHANIC BASED ON
GAMEPLAY CHARACTERISTICS**

CLAIM OF PRIORITY

[0001] This application is a continuation of and claims the benefit of priority under 35 U.S.C. §120 to U.S. patent application Ser. No. 13/114,900, filed on May 24, 2011, which is hereby incorporated by reference herein in its entirety.

TECHNICAL FIELD

[0002] The present disclosure generally relates to games and applications in general and, in particular embodiments, to computer-implemented online games.

BACKGROUND

[0003] In many games, there is a virtual world or some other imagined playing space where a player/user of the game controls one or more player characters (herein “character,” “player character,” or “PC”). Player characters can be considered in-game representations of the controlling player. As used herein, the terms “player,” “user,” “entity,” and “friend” may refer to the in-game player character controlled by that player, user, entity, or friend, unless context suggests otherwise. The game display can display a representation of the player character. A game engine accepts inputs from the player, determines player character actions, decides the outcomes of events, and presents the player with a game display illuminating what happened. In some games, there are multiple players, wherein each player controls one or more player characters.

[0004] In many computer games, there are various types of in-game assets (aka “rewards” or “loot”) that a player character can obtain within the game. For example, a player character may acquire game points, gold coins, experience points, character levels, character attributes, virtual cash, game keys, or other in-game items of value. In many computer games, there are also various types of in-game obstacles that a player must overcome to advance within the game. In-game obstacles can include tasks, puzzles, opponents, levels, gates, actions, and so forth. In some games, a goal of the game may be to acquire certain in-game assets, which can then be used to complete in-game tasks or to overcome certain in-game obstacles. For example, a player may be able to acquire a virtual key (i.e., the in-game asset) that can then be used to open a virtual door (i.e., the in-game obstacle).

[0005] An electronic social networking system typically operates with one or more social networking servers providing interaction between users such that a user can specify other users of the social networking system as “friends.” A collection of users and the “friend” connections between users can form a social graph that can be traversed to find second, third and more remote connections between users, much like a graph of nodes connected by edges can be traversed.

[0006] Many online computer games are operated on an online social network. Such a network allows both users and other parties to interact with the computer games directly, whether to play the games or to retrieve game- or user-related information. Internet users may maintain one or more accounts with various service providers, including, for example, online game networking systems and online social networking systems. Online systems can typically be

accessed using browser clients (e.g., MICROSOFT INTERNET EXPLORER, MOZILLA FIREFOX, GOOGLE CHROME).

[0007] In many computer games, there are various types of in-game actions that a player character can make within the game. For example, a player character in an online role-playing game may be able to interact with other player characters, build a virtual house, attack enemies, go on a quest, go to a virtual store to buy/sell virtual items, and so forth. A player character in an online poker game may be able to play at specific tables, place bets of virtual currency for certain amounts, play or fold certain hands, play in an online poker tournament, and so forth.

[0008] Matching players for an online game presents additional challenges since players may wish to join an instance of a game without previous knowledge of other available players. One factor for matching players is typically skill level, which can be based, for example, on a win-loss record or a rating system. For example, in some operational settings, players are randomly matched within a skill level. In multiplayer synchronous games, where players are simultaneously engaged, physical proximity may also be considered as a factor for matching players in order to avoid problems due to server lag. In multiplayer asynchronous games, however, where players are not constrained to be simultaneously engaged, server proximity is less relevant and other criteria may be more useful for promoting a desirable player experience. Thus, there is a need for improved methods for matching players in online asynchronous games.

BRIEF DESCRIPTION OF THE DRAWINGS

[0009] FIG. 1 illustrates an example of a system for implementing particular disclosed embodiments.

[0010] FIG. 2 illustrates an example social network.

[0011] FIG. 3 illustrates a method of matching players based on gameplay characteristics according to an example embodiment.

[0012] FIG. 4 illustrates an example method of matching players based on gameplay characteristics including playing frequency, playing intensity, or playing style.

[0013] FIG. 5 illustrates an example method of matching players that includes classifying users into groups that each correspond to a different range of gameplay values for some measure of gameplay characteristics.

[0014] FIG. 6 illustrates a method of matching players based on chat characteristics according to an example embodiment.

[0015] FIG. 7 illustrates an example method of matching players based on chat characteristics including chat frequency, chat intensity, or chat substance.

[0016] FIG. 8 illustrates an example method of matching players that includes classifying users into groups that each correspond to a different range of chat values for some measure of chat characteristics.

[0017] FIG. 9 illustrates an example data flow in a system.

[0018] FIG. 10 illustrates an example network environment.

[0019] FIG. 11 illustrates an example computer system architecture.

DESCRIPTION OF EXAMPLE EMBODIMENTS

[0020] FIG. 1 illustrates an example of a system for implementing various disclosed embodiments. In particular

embodiments, system 100 comprises player 101, social networking system 120a, game networking system 120b, client system 130, and network 160. The components of system 100 can be connected to each other in any suitable configuration, using any suitable type of connection. The components may be connected directly or over a network 160, which may be any suitable network. For example, one or more portions of network 160 may be an ad hoc network, an intranet, an extranet, a virtual private network (VPN), a local area network (LAN), a wireless LAN (WLAN), a wide area network (WAN), a wireless WAN (WWAN), a metropolitan area network (MAN), a portion of the Internet, a portion of the Public Switched Telephone Network (PSTN), a cellular telephone network, another type of network, or a combination of two or more such networks.

[0021] Social networking system 120a is a network-addressable computing system that can host one or more social graphs. Social networking system 120a can generate, store, receive, and transmit social networking data. Social networking system 120a can be accessed by the other components of system 100 either directly or via network 160. Game networking system 120b is a network-addressable computing system that can host one or more online games. Game networking system 120b can generate, store, receive, and transmit game-related data, such as, for example, game account data, game input, game state data, and game displays. Game networking system 120b can be accessed by the other components of system 100 either directly or via network 160. Player 101 may use client system 130 to access, send data to, and receive data from social networking system 120a and game networking system 120b. Client system 130 can access social networking system 120 or game networking system 120b directly, via network 160, or via a third-party system. As an example and not by way of limitation, client system 130 may access game networking system 120b via social networking system 120a. Client system 130 can be any suitable computing device, such as a personal computer, laptop, cellular phone, smart phone, computing tablet, and so forth.

[0022] Although FIG. 1 illustrates a particular number of players 101, social networking systems 120a, game networking systems 120b, client systems 130, and networks 160, this disclosure contemplates any suitable number of players 101, social networking systems 120a, game networking systems 120b, client systems 130, and networks 160. As an example and not by way of limitation, system 100 may include one or more game networking systems 120b and no social networking systems 120a. As another example and not by way of limitation, system 100 may include a system that comprises both social networking system 120a and game networking system 120b. Moreover, although FIG. 1 illustrates a particular arrangement of player 101, social networking system 120a, game networking system 120b, client system 130, and network 160, this disclosure contemplates any suitable arrangement of player 101, social networking system 120a, game networking system 120b, client system 130, and network 160.

[0023] The components of system 100 may be connected to each other using any suitable connections 110. For example, suitable connections 110 include wireline (such as, for example, Digital Subscriber Line (DSL) or Data Over Cable Service Interface Specification (DOCSIS)), wireless (such as, for example, Wi-Fi or Worldwide Interoperability for Microwave Access (WiMAX)) or optical (such as, for example, Synchronous Optical Network (SONET) or Synchronous

Digital Hierarchy (SDH)) connections. In particular embodiments, one or more connections 110 each include an ad hoc network, an intranet, an extranet, a VPN, a LAN, a WLAN, a WAN, a WWAN, a MAN, a portion of the Internet, a portion of the PSTN, a cellular telephone network, another type of connection, or a combination of two or more such connections. Connections 110 need not necessarily be the same throughout system 100. One or more first connections 110 may differ in one or more respects from one or more second connections 110. Although FIG. 1 illustrates particular connections between player 101, social networking system 120a, game networking system 120b, client system 130, and network 160, this disclosure contemplates any suitable connections between player 101, social networking system 120a, game networking system 120b, client system 130, and network 160. As an example and not by way of limitation, in particular embodiments, client system 130 may have a direct connection to social networking system 120a or game networking system 120b, bypassing network 160.

Online Games and Game Systems

[0024] In an online computer game, a game engine manages the game state of the game. Game state comprises all game play parameters, including player character state, non-player character (NPC) state, in-game object state, game world state (e.g., internal game clocks, game environment), and other game play parameters. Each player 101 controls one or more player characters (PCs). The game engine controls all other aspects of the game, including non-player characters (NPCs), and in-game objects. The game engine also manages the game state, including player character state for currently active (online) and inactive (offline) players.

[0025] An online game can be hosted by game networking system 120b, which can be accessed using any suitable connection with a suitable client system 130. A player may have a game account on game networking system 120b, wherein the game account can contain a variety of information associated with the player (e.g., the player's personal information, financial information, purchase history, player character state, and game state). In some embodiments, a player may play multiple games on game networking system 120b, which may maintain a single game account for the player with respect to all the games, or multiple individual game accounts for each game with respect to the player. In some embodiments, game networking system 120b can assign a unique identifier to each player 101 of an online game hosted on game networking system 120b. Game networking system 120b can determine that a player 101 is accessing the online game by reading the user's cookies, which may be appended to HyperText Transfer Protocol (HTTP) requests transmitted by client system 130, and/or by the player 101 logging onto the online game.

[0026] In particular embodiments, player 101 may access an online game and control the game's progress via client system 130 (e.g., by inputting commands to the game at the client device). Client system 130 can display the game interface, receive inputs from player 101, transmit user inputs or other events to the game engine, and receive instructions from the game engine. The game engine can be executed on any suitable system (such as, for example, client system 130, social networking system 120a, or game networking system 120b). As an example and not by way of limitation, client system 130 can download client components of an online game, which are executed locally, while a remote game

server, such as game networking system **120b**, provides back-end support for the client components and may be responsible for maintaining application data of the game, processing the inputs from the player, updating and/or synchronizing the game state based on the game logic and each input from the player, and transmitting instructions to client system **130**. As another example and not by way of limitation, each time player **101** provides an input to the game through the client system **130** (such as, for example, by typing on the keyboard or clicking the mouse of client system **130**), the client components of the game may transmit the player's input to game networking system **120b**.

Game Systems, Social Networks, and Social Graphs

[0027] In an online multiplayer game, players may control player characters (PCs), while a game engine controls non-player characters (NPCs) and game features. The game engine also manages player character state and game state and tracks the state for currently active (i.e., online) players and currently inactive (i.e., offline) players. A player character can have a set of attributes and a set of friends associated with the player character. As used herein, the term "player character state" can refer to any in-game characteristic of a player character, such as location, assets, levels, condition, health, status, inventory, skill set, name, orientation, affiliation, specialty, and so on. Player characters may be displayed as graphical avatars within a user interface of the game. In other implementations, no avatar or other graphical representation of the player character is displayed. Game state encompasses the notion of player character state and refers to any parameter value that characterizes the state of an in-game element, such as a non-player character, a virtual object (such as a wall or castle), and so forth. The game engine may use player character state to determine the outcome of game events, while sometimes also considering set or random variables. Generally, a player character's probability of having a more favorable outcome is greater when the player character has a better state. For example, a healthier player character is less likely to die in a particular encounter relative to a weaker player character or non-player character. In some embodiments, the game engine can assign a unique client identifier to each player.

[0028] In particular embodiments, player **101** may access particular game instances of an online game. A game instance is a copy of a specific game play area that is created during runtime. In particular embodiments, a game instance is a discrete game play area where one or more players **101** can interact in synchronous or asynchronous play. A game instance may be, for example, a level, zone, area, region, location, virtual space, or other suitable play area. A game instance may be populated by one or more in-game objects. Each object may be defined within the game instance by one or more variables, such as, for example, position, height, width, depth, direction, time, duration, speed, color, and other suitable variables. A game instance may be exclusive (i.e., accessible by specific players) or non-exclusive (i.e., accessible by any player). In particular embodiments, a game instance is populated by one or more player characters controlled by one or more players **101** and one or more in-game objects controlled by the game engine. When accessing an online game, the game engine may allow player **101** to select a particular game instance to play from a plurality of game instances. Alternatively, the game engine may automatically select the game instance that player **101** will access. In par-

ticular embodiments, an online game comprises only one game instance that all players **101** of the online game can access.

[0029] In particular embodiments, a specific game instance may be associated with one or more specific players. A game instance is associated with a specific player when one or more game parameters of the game instance are associated with the specific player. As an example and not by way of limitation, a game instance associated with a first player may be named "First Player's Play Area." This game instance may be populated with the first player's PC and one or more in-game objects associated with the first player. In particular embodiments, a game instance associated with a specific player may only be accessible by that specific player. As an example and not by way of limitation, a first player may access a first game instance when playing an online game, and this first game instance may be inaccessible to all other players. In other embodiments, a game instance associated with a specific player may be accessible by one or more other players, either synchronously or asynchronously with the specific player's game play. As an example and not by way of limitation, a first player may be associated with a first game instance, but the first game instance may be accessed by all first-degree friends in the first player's social network. In particular embodiments, the game engine may create a specific game instance for a specific player when that player accesses the game. As an example and not by way of limitation, the game engine may create a first game instance when a first player initially accesses an online game, and that same game instance may be loaded each time the first player accesses the game. As another example and not by way of limitation, the game engine may create a new game instance each time a first player accesses an online game, wherein each game instance may be created randomly or selected from a set of predetermined game instances. In particular embodiments, the set of in-game actions available to a specific player may be different in a game instance that is associated with that player compared to a game instance that is not associated with that player. The set of in-game actions available to a specific player in a game instance associated with that player may be a subset, superset, or independent of the set of in-game actions available to that player in a game instance that is not associated with him. As an example and not by way of limitation, a first player may be associated with Blackacre Farm in an online farming game. The first player may be able to plant crops on Blackacre Farm. If the first player accesses a game instance associated with another player, such as Whiteacre Farm, the game engine may not allow the first player to plant crops in that game instance. However, other in-game actions may be available to the first player, such as watering or fertilizing crops on Whiteacre Farm.

[0030] In particular embodiments, a game engine can interface with a social graph. Social graphs are models of connections between entities (e.g., individuals, users, contacts, friends, players, player characters, non-player characters, businesses, groups, associations, concepts, etc.). These entities are considered "users" of the social graph; as such, the terms "entity" and "user" may be used interchangeably when referring to social graphs herein. A social graph can have a node for each entity and edges to represent relationships between entities. A node in a social graph can represent any entity. In particular embodiments, a unique client identifier can be assigned to each user in the social graph. In general, this disclosure assumes that at least one entity of a social

graph is a player or player character in an online multiplayer game, although this disclosure is applicable to players or player characters that are not characterized as entities of a social graph.

[0031] The minimum number of edges required to connect a player (or player character) to another user is considered the degree of separation between them. For example, where the player and the user are directly connected (one edge), they are deemed to be separated by one degree of separation. The user would be a so-called “first-degree friend” of the player. Where the player and the user are connected through one other user (two edges), they are deemed to be separated by two degrees of separation. This user would be a so-called “second-degree friend” of the player. Where the player and the user are connected through N edges (or N-1 other users), they are deemed to be separated by N degrees of separation. This user would be a so-called “Nth-degree friend.” As used herein, the term “friend” means only first-degree friends, unless context suggests otherwise.

[0032] Within the social graph, each player (or player character) has a social network. A player’s social network includes all users in the social graph within N_{max} degrees of the player, where N_{max} is the maximum degree of separation allowed by the system managing the social graph (such as, for example, social networking system **120a** or game networking system **120b**). In one embodiment, N_{max} equals 1, such that the player’s social network includes only first-degree friends. In another embodiment, N_{max} is unlimited and the player’s social network is coextensive with the social graph.

[0033] In particular embodiments, the social graph is managed by game networking system **120b**, which is managed by the game operator. In other embodiments, the social graph is part of a social networking system **120a** managed by a third-party (e.g., Facebook, Friendster, Myspace). In yet other embodiments, player **101** has a social network on both game networking system **120b** and social networking system **120a**, wherein player **101** can have a social network on the game networking system **120b** that is a subset, superset, or independent of the player’s social network on social networking system **120a**. In such combined systems, game network system **120b** can maintain social graph information with edge type attributes that indicate whether a given friend is an “in-game friend,” an “out-of-game friend,” or both. The various embodiments disclosed herein are operable when the social graph is managed by social networking system **120a**, game networking system **120b**, or both.

[0034] FIG. 2 shows an example of a social network within a social graph. As shown, Player **201** can be associated, connected or linked to various other users, or “friends,” within the social network **200**. These associations, connections or links can track relationships between users within the social network **200** and are commonly referred to as online “friends” or “friendships” between users. Each friend or friendship in a particular user’s social network within a social graph is commonly referred to as a “node.” For purposes of illustration and not by way of limitation, the details of social network **200** will be described in relation to Player **201**. As used herein, the terms “player” and “user” can be used interchangeably and can refer to any user or character in an online multiuser game system or social networking system. As used herein, the term “friend” can mean any node within a player’s social network.

[0035] As shown in FIG. 2, Player **201** has direct connections with several friends. When Player **201** has a direct connection with another individual, that connection is

referred to as a first-degree friend. In social network **200**, Player **201** has four first-degree friends. That is, Player **201** is directly connected to Friend 1_1 **211**, Friend 2_1 **221**, Friend 3_1 **231**, and Friend 4_1 **241**. In a social graph, it is possible for individuals to be connected to other individuals through their first-degree friends (i.e., friends of friends). As described above, each edge required to connect a player to another user is considered the degree of separation. For example, FIG. 2 shows that Player **201** has three second-degree friends to which he is connected via his connection to his first-degree friends. Second-degree Friend 1_2 **212** and Friend 2_2 **222** are connected to Player **201** via his first-degree Friend 1_1 **211**, and second-degree Friend 4_2 **242** is connected to Player **201** via his first-degree Friend 3_1 **231**. The limit on the depth of friend connections, or the number of degrees of separation for associations, that Player **201** is allowed is typically dictated by the restrictions and policies implemented by social networking system **120a**.

[0036] In various embodiments, Player **201** can have Nth-degree friends connected to him through a chain of intermediary degree friends as indicated in FIG. 2. For example, Nth-degree Friend 1_N **219** is connected to Player **201** via second-degree Friend 3_2 **232** and one or more other higher-degree friends. Various embodiments may take advantage of and utilize the distinction between the various degrees of friendship relative to Player **201**.

[0037] In particular embodiments, a player (or player character) can have a social graph within an online multiplayer game that is maintained by the game engine and another social graph maintained by a separate social networking system. FIG. 2 depicts an example of in-game social network **260** and out-of-game social network **250**. In this example, Player **201** has out-of-game connections **255** to a plurality of friends, forming out-of-game social network **250**. Here, Friend 1_1 **211** and Friend 2_1 **221** are first-degree friends with Player **201** in his out-of-game social network **250**. Player **201** also has in-game connections **265** to a plurality of players, forming in-game social network **260**. Here, Friend 2_1 **221**, Friend 3_1 **231**, and Friend 4_1 **241** are first-degree friends with Player **201** in his in-game social network **260**, and Friend 4_2 **242** is a second-degree friend. In some embodiments, it is possible for a friend to be in both the out-of-game social network **250** and the in-game social network **260**. Here, Friend 2_1 **221** has both an out-of-game connection **255** and an in-game connection **265** with Player **201**, such that Friend 2_1 **221** is in both Player **201**’s in-game social network **260** and Player **201**’s out-of-game social network **250**.

[0038] As with other social networks, Player **201** can have second-degree and higher-degree friends in both his in-game and out of game social networks. In some embodiments, it is possible for Player **201** to have a friend connected to him both in his in-game and out-of-game social networks, wherein the friend is at different degrees of separation in each network. For example, if Friend 2_2 **222** had a direct in-game connection with Player **201**, Friend 2_2 **222** would be a second-degree friend in Player **201**’s out-of-game social network, but a first-degree friend in Player **201**’s in-game social network. In particular embodiments, a game engine can access in-game social network **260**, out-of-game social network **250**, or both.

[0039] In particular embodiments, the connections in a player’s in-game social network can be formed both explicitly (e.g., users must “friend” each other) and implicitly (e.g., the system observes user behaviors and “friends” users to each other). Unless otherwise indicated, reference to a friend con-

nection between two or more players can be interpreted to cover both explicit and implicit connections, using one or more social graphs and other factors to infer friend connections. The friend connections can be unidirectional or bidirectional. It is also not a limitation of this description that two players who are deemed “friends” for the purposes of this disclosure are not friends in real life (i.e., in disintermediated interactions or the like), but that could be the case.

Game Systems and Game Interfaces

[0040] A game event may be an outcome of an engagement, a provision of access, rights and/or benefits, or the obtaining of some assets (e.g., health, money, strength, inventory, land, etc.). A game engine determines the outcome of a game event according to a variety of factors, such as the game rules, a player character’s in-game actions, player character state, game state, interactions of other player characters, and random calculations. Engagements can include simple tasks (e.g., plant a crop, clean a stove), complex tasks (e.g., build a farm or business, run a café), or other events.

[0041] An online game can be hosted by a game networking system, which can be accessed over any suitable network with an appropriate client system (e.g., as in FIG. 10). A player may have a game system account on a game system, wherein the game system account can contain a variety of information about the player (e.g., the player’s personal information, player character state, game state, etc.). In various embodiments, an online game can be embedded into a third-party website. The game can be hosted by the networking system of the third-party website, or it can be hosted on the game system and merely accessed via the third-party website. The embedded online game can be hosted solely on a server of the game system or use a third-party vendor server. In addition, any combination of the functions of the present disclosure can be hosted on or provided from any number of distributed network resources. For example, one or more executable code objects that implement all or a portion of the game can be downloaded to a client system for execution.

[0042] A webpage-based game interface for an online game may be accessed by a browser client (e.g., MICROSOFT INTERNET EXPLORER, MOZILLA FIREFOX, GOOGLE CHROME). In various embodiments, a user of a client system 130 can use a browser client to access the online game over the Internet (or other suitable network). A game interface may be automatically generated and presented to the user in response to the user visiting or accessing the game operator’s website or a third-party’s website from client system 130 with a browser client. Game system 120b can transmit data to client system 130, allowing it to display the game interface, which is typically some type of graphic user interface. For example, the webpage downloaded to client system 130 may include an embedded call that causes client system 130 to download an executable object, such as a Flash .SWF object, which executes on client system 130 and renders the game within the context of the webpage. Other interface types are possible, such as server-side rendering and the like. Typically a game interface is configured to receive signals from the user via client system 130. For example, the user may click on a game interface or enter commands from a keyboard or other suitable input device. The game engine can respond to these signals to allow game play. The display of a game interface may change based on the output of the game engine, the input of the player, and other signals from game system 120b and client system 130.

[0043] Typically a game interface can display various game components, such as the game environment, options available to the player (e.g., in-game actions, preferences, settings, etc.), game results, and so forth. Some components of the game interface may be static, while others may be dynamic (e.g., changing with game play). The user may be able to interact with some components (e.g., player character, NPCs, virtual objects, etc.) and not interact with other components (e.g., the background of the virtual world, such as the virtual street or sidewalk). The user can engage in specific in-game actions or activities by providing input to the game interface.

Virtual Currency

[0044] In various embodiments, players within the game can acquire virtual currency. In such games, the virtual currency might be represented by virtual coins, virtual cash, or by a number or value stored by the server for that player’s benefit. Such virtual currency represents units of value for use in the online game system and is analogous to legal currency. Virtual currency can be purchased in one or more actual cash or credit transactions by a player, where the legal currency is transferred using a credit/debit/charge card transaction conveyed over a financial network. In some embodiments, a player may earn virtual currency by taking action in the game. For example, a player may be rewarded with one or more units of virtual currency after completing a task, quest, challenge, or mission within the game. For example, a farming game might reward 10 gold coins each time a virtual crop is harvested.

[0045] In some embodiments, virtual currency can be used to purchase one or more in-game assets or other benefits. For example, a player may be able to exchange virtual currency for a desired level, access, right, or item in an online game. In one embodiment, legal currency can be used to directly purchase an in-game asset or other benefit. The player can select the desired in-game asset or other benefit. Once the selections are made, the player can place the order to purchase the in-game asset or other benefit. This order is received by the game system, which can then process the order. If the order is processed successfully, an appropriate financial account associated with the player can be debited by the amount of virtual currency or legal currency needed to buy the selected in-game asset or other benefit.

[0046] In some embodiments, multiple types of virtual currency may be available for purchase from the game system operator. For example, an online game may have virtual gold coins and virtual cash. The different types of virtual currency may have different exchange rates with respect to legal currency and each other. For example, a player may be able to exchange \$1 in legal currency for either 100 virtual gold coins or \$2 in virtual cash, but virtual gold coins may not be exchanged for virtual cash. Similarly, where in-game assets and other benefits can be purchased with virtual currency, they may have different exchange rates with respect to the different types of virtual currency. For example, a player may be able to buy a virtual business object for \$10 in virtual cash, but may not purchase the virtual business object for virtual gold coins alone. In some embodiments, certain types of virtual currency can be acquired by engaging in various in-game actions while other types of virtual currency can only be acquired by exchanging legal currency. For example, a player may be able to acquire virtual gold coins by selling virtual goods in a business, but can only acquire virtual cash by

exchanging legal currency. In some implementations, virtual cash may also be awarded for leveling up in the game.

Player-Matching Mechanic for Asynchronous Games

[0047] In addition to an opponent's skill level, the quality of a player's experience in an online asynchronous game may be affected by other factors related to his opponent's moves and social behavior related to those moves. For example, when the playing frequency (e.g., how often a player makes a move in the game) varies substantially between two players, one of them may lose interest or even forget about the game. Similarly, chatting frequency (e.g., how often a player chats with an opponent during a game) varies substantially between players, but can significantly affect engagement of other users. For example, while not making a move, a user may be enticed to enter a game because he has received a chat message from another player. On the other hand, if a player does not respond to chats, one or both of the players may become frustrated with the experience. In accordance with certain embodiments, a player-matching mechanic facilitates player matching in online asynchronous games by comparing user values for at least one of gameplay characteristics or chat characteristics.

[0048] FIG. 3 shows a flowchart that illustrates a method **300** of matching two or more players in an online asynchronous game according to an example embodiment. Typically in an asynchronous game, players specify moves at different times so that they need not be present or active at the same time. In many cases, a game includes multiple rounds in which players alternate moves at different times (e.g., chess). However, in some cases the game may include multiple rounds in which players specify moves at different times in each round before a common deadline in that round (e.g., certain multi-player games). In some cases the moves may each include multiple discrete component moves.

[0049] A first operation **302** includes receiving values for moves corresponding to users playing in instances of the online asynchronous game where players specify moves at different times. A second operation **304** includes determining gameplay characteristics for the users from the moves to characterize gameplay patterns over time. A third operation **306** includes matching a first user and a second user for a selected instance of the online asynchronous game by comparing their corresponding gameplay characteristics.

[0050] The gameplay characteristics may include a variety of move-related features. FIG. 4 shows an example method **310**, where determining gameplay characteristics **312** includes calculating values for one or more of playing frequency **314**, playing intensity **316**, or playing style **318**. For example, the playing frequency **314** may be calculated as a value for how often that user plays the online asynchronous game with respect to a reference time zone (e.g., typically once a day by Eastern Standard Time (EST)). In this context, the reference time zone may be more specifically and narrowly defined, for example, as a portion of a conventional time zone (e.g., 8 pm-4 am EST). Alternatively, the playing frequency **314** may be calculated as a value for how long that user waits in the online asynchronous game before responding to another player (e.g., typically ten hours). As another example, playing intensity **316** may be calculated as a value for how many simultaneous instances of the online asynchronous game that user plays (e.g., typically ten simultaneous games). As yet another example, playing style **318** may be calculated as one or more values for how often that user

employs selected move patterns in the online asynchronous game (e.g., typically includes complex strategy moves). These selected move patterns may include selectively enabled special features of a game that some but not all users prefer to include in the game experience.

[0051] Then, with available gameplay characteristics, it is possible to match players with similar characteristics or selectively dissimilar characteristics depending on the requirements of the operational setting. For example, in some cases it may be desirable to match relatively similar players to ensure compatibility (e.g., similar playing frequencies). Similarity may also include players from different time zones who are active simultaneously. For example, someone who plays every morning in Japan could be matched with someone who plays at night-time in the United States in the case where they wish to play at the same or similar times relative to the reference time zone (e.g., EST). Alternatively, it may be desirable to match players with quantified dissimilarities (e.g., different playing frequencies) to alter the players' gaming experience and measure the results (e.g., whether the lower-frequency player now plays faster or the higher-frequency player now plays slower). FIG. 5 shows an example method **320** that includes classifying users into groups that each correspond to a different range of gameplay values for some measure of gameplay characteristics (e.g., frequency of play) at a first operation **322**. The method **320** then includes matching the first user and the second user by selecting them from an identical group or from different groups at a second operation **324**. For example, the different groups may be characterized by a threshold difference between gameplay values in the two groups (e.g., with respect to minimum and maximum playing frequency values for each group). The selection within a group can be carried out randomly (e.g., with a conventional random number generator) or by applying another selection principle such as skill level or chat characteristics as discussed below.

[0052] In addition to gameplay characteristics based on moves played, players may be matched by the characteristics of chat communications between players in an online asynchronous game. FIG. 6 shows a flowchart that illustrates a method **330** of matching two or more players in an online asynchronous game according to an example embodiment.

[0053] A first operation **332** includes receiving values for chat communications corresponding to users playing in instances of the online asynchronous game where players specify moves at different times. For example, the chat communications may occur during the moves or between moves of the game. A second operation **334** includes determining chat characteristics for the users from the chat communications to characterize chat patterns over time. A third operation **336** includes matching a first user and a second user for a selected instance of the online asynchronous game by comparing their corresponding chat characteristics.

[0054] The chat characteristics may include a variety of move-related features. FIG. 7 shows an example method **340**, where determining chat characteristics **342** includes calculating values for one or more of chat frequency **344**, chat intensity **346** or chat substance **348**. For example, the chat frequency **344** may be calculated as a value for how often that user initiates a chat communication during the online asynchronous game (e.g., typically after every move). Alternatively, the chat frequency **344** may be calculated as a value for how often that user participates in a chat communication during the online asynchronous game (e.g., typically at the

start and the end of a game). As another example, chat intensity **346** may be calculated as a value for a size of a chat communication for that user in the online asynchronous game. For example, this size (e.g., number of words or characters) may be calculated for a typical or random discrete chat communication or alternatively for the union of all chat communications during an instance of the game. As yet another example, chat substance **348** may be calculated as one or more values for how often that user includes selected text elements in a chat communication during the online asynchronous game (e.g., typically uses complimentary words to describe opponent).

[0055] Then, similarly to the above-described matching by gameplay characteristics, it is possible to match players with similar chat characteristics or selectively dissimilar chat characteristics depending on the requirements of the operational setting. For example, in some cases it may be desirable to match relatively similar players to ensure compatibility (e.g., similar chat frequencies). Alternatively, it may be desirable to match players with quantified dissimilarities (e.g., different chat frequencies, typically initiates chats or chats with friend-list players versus chatting with random players) to alter the players' gaming experience and measure the results (e.g., whether the lower-frequency player now chats more frequently or the higher-frequency player now chats less frequently). FIG. **8** shows an example method **350** that includes classifying users into groups that each correspond to a different range of chat values for some measure of chat characteristics (e.g., chat frequency) at a first operation **352**. The method **350** then includes matching the first user and the second user by selecting them from an identical group or from different groups at a second operation **354**. For example, the different groups may be characterized by a threshold difference between chat values in the two groups (e.g., with respect to minimum and maximum chat frequency values for each group).

[0056] In some embodiments chat values may be used in combination with gameplay values for matching players. For example, players may first be separated into groups by comparing gameplay values, and then players may be selected from an identical group or from different groups by comparing chat values. Similarly, players may be first grouped according to gameplay values, then grouped according to chat values, and then randomly selected from identical or different groups. As discussed above, skill level (e.g., a skill rating) may also be used in the selection process, for example, by first grouping for skill level, then grouping for gameplay values, then grouping for chat values, and then randomly selecting from identical or different groups. In general, separate or recursive groupings can be made according to one or more criteria for skill level, gameplay values or chat values, and the selection process may include one or more of these criteria or a randomization process.

[0057] In some embodiments the asynchronous game may be considered as a family of games that share common features so that gameplay characteristics or chat characteristics may be used to match players in an instance of a specific game variant within the family. For example, gameplay characteristics and chat characteristics corresponding to a family of strategic games may be used to match two players in an instance of a chess game even if those two players had not previously played chess in the online system.

[0058] Additional embodiments relate to an apparatus for carrying out any one of the above-described methods (e.g., as

a game mechanic), where the apparatus includes a computer for executing computer instructions related to the method. In this context the computer may be a general-purpose computer including, for example, a processor, memory, storage, and input/output devices (e.g., keyboard, display, disk drive, Internet connection, etc.). However, the computer may include circuitry or other specialized hardware for carrying out some or all aspects of the method. In some operational settings, the apparatus or computer may be configured as a system that includes one or more modular units, each of which is configured to carry out some aspects of the method either in software, in hardware or in some combination thereof. For example, the system may be configured as part of a computer network that includes the Internet. At least some values for the results of the method can be saved for later use in a computer-readable medium, including memory units (e.g., RAM (Random Access Memory), ROM (Read Only Memory)) and storage devices (e.g., hard-disk systems, optical storage systems).

[0059] Additional embodiments also relate to a computer-readable medium that stores (e.g., tangibly embodies) a computer program for carrying out any one of the above-described methods by means of a computer. The computer program may be written, for example, in a general-purpose programming language (e.g., C, C++) or some specialized application-specific language. The computer program may be stored as an encoded file in some useful format (e.g., binary, American Standard Code for Information Interchange (ASCII)). In some contexts, the computer-readable medium may be alternatively described as a computer-useable medium, a computer-storage medium, a computer-program medium, machine-readable medium or some alternative non-transitory storage medium. Depending on the operational setting, specified values for the above-described methods may correspond to input files for the computer program or computer.

Data Flow

[0060] FIG. **9** illustrates an example data flow between the components of system **500**. In particular embodiments, system **500** can include client system **530**, social networking system **520a**, and game networking system **520b**. The components of system **500** can be connected to each other in any suitable configuration and using any suitable type of connection. The components may be connected directly or over any suitable network. Client system **530**, social networking system **520a**, and game networking system **520b** can each have one or more corresponding data stores such as local data store **525**, social data store **545**, and game data store **565**, respectively. Social networking system **520a** and game networking system **520b** can also have one or more servers that can communicate with client system **530** over an appropriate network. Social networking system **520a** and game networking system **520b** can have, for example, one or more internet servers for communicating with client system **530** via the Internet. Similarly, social networking system **520a** and game networking system **520b** can have one or more mobile servers for communicating with client system **530** via a mobile network (e.g., Global System for Mobile Communications (GSM), Personal Communications Service (PCS), Wireless Personal Area Network (WPAN), Wi-Fi, etc.). In some embodiments, one server may be able to communicate with client system **530** over both the Internet and a mobile network. In other embodiments, separate servers can be used.

[0061] Client system 530 can receive and transmit data 523 to and from game networking system 520b. This data can include, for example, webpages, messages, game inputs, game displays, HTTP packets, data requests, transaction information, updates, and other suitable data. At some other time, or at the same time, game networking system 520b can communicate data 543, 547 (e.g., game state information, game system account information, page info, messages, data requests, updates, etc.) with other networking systems, such as social networking system 520a (e.g., FACEBOOK, MYSPACE, etc.). Client system 530 can also receive and transmit data 527 to and from social networking system 520a. This data can include, for example, webpages, messages, social graph information, social network displays, HTTP packets, data requests, transaction information, updates, and other suitable data.

[0062] Communication between client system 530, social networking system 520a, and game networking system 520b can occur over any appropriate electronic communication medium or network using any suitable communications protocols. For example, client system 530, as well as various servers of the systems described herein, may include Transport Control Protocol/Internet Protocol (TCP/IP) networking stacks to provide for datagram and transport functions. Of course, any other suitable network and transport layer protocols can be utilized.

[0063] In addition, hosts or end-systems described herein may use a variety of higher layer communications protocols, including client-server (or request-response) protocols, such as HTTP. Other communications protocols, such as HTTP Secure (HTTP-S), File Transfer Protocol (FTP), Simple Network Management Protocol (SNMP), Telnet, and a number of other protocols, may also be used. In addition, a server in one interaction context may be a client in another interaction context. In particular embodiments, the information transmitted between hosts may be formatted as HyperText Markup Language (HTML) documents including HTMLS documents. Other structured document languages or formats can be used, such as Extensible Markup Language (XML), and the like. Executable code objects, such as JavaScript and ActionScript, can also be embedded in the structured documents.

[0064] In some client-server protocols, such as the use of HTML over HTTP, a server generally transmits a response to a request from a client. The response may comprise one or more data objects. For example, the response may comprise a first data object, followed by subsequently transmitted data objects. In particular embodiments, a client request may cause a server to respond with a first data object, such as an HTML page, which itself refers to other data objects. A client application, such as a browser, will request these additional data objects as it parses or otherwise processes the first data object.

[0065] In particular embodiments, an instance of an online game can be stored as a set of game state parameters that characterize the state of various in-game objects, such as, for example, player character state parameters, non-player character parameters, and virtual item parameters. In particular embodiments, a game state is maintained in a database as a serialized, unstructured string of text data as a so-called Binary Large Object (BLOB). When a player accesses an online game on game networking system 520b, the BLOB containing the game state for the instance corresponding to the player can be transmitted to client system 530 for pro-

cessing by a client-side executable object. In particular embodiments, the client-side executable may be a FLASH-based game, which can de-serialize the game state data in the BLOB. As a player plays the game, the game logic implemented at client system 530 maintains and modifies the various game state parameters locally. The client-side game logic may also batch game events, such as mouse clicks, and transmit these events to game networking system 520b. Game networking system 520b may itself operate by retrieving a copy of the BLOB from a database or an intermediate memory cache (memcache) layer. Game networking system 520b can also de-serialize the BLOB to resolve the game state parameters and execute its own game logic based on the events in the batch file of events transmitted by the client to synchronize the game state on the server side. Game networking system 520b may then re-serialize the game state, now modified, into a BLOB and pass this to a memory cache layer for lazy updates to a persistent database.

[0066] With a client-server environment in which the online games may run, one server system, such as game networking system 520b, may support multiple client systems 530. At any given time, there may be multiple players at multiple client systems 530 all playing the same online game. In practice, the number of players playing the same game at the same time may be very large. As the game progresses with each player, multiple players may provide different inputs to the online game at their respective client systems 530, and multiple client systems 530 may transmit multiple player inputs and/or game events to game networking system 520b for further processing. In addition, multiple client systems 530 may transmit other types of application data to game networking system 520b.

[0067] In particular embodiments, a computer-implemented game may be a text-based or turn-based game implemented as a series of web pages that are generated after a player selects one or more actions to perform. The web pages may be displayed in a browser client executed on client system 530. As an example and not by way of limitation, a client application downloaded to client system 530 may operate to serve a set of webpages to a player. As another example and not by way of limitation, a computer-implemented game may be an animated or rendered game executable as a stand-alone application or within the context of a webpage or other structured document. In particular embodiments, the computer-implemented game may be implemented using Adobe Flash-based technologies. As an example and not by way of limitation, a game may be fully or partially implemented as a SWF object that is embedded in a web page and executable by a Flash media player plug-in. In particular embodiments, one or more described webpages may be associated with, or accessed by, social networking system 520a. This disclosure contemplates using any suitable application for the retrieval and rendering of structured documents hosted by any suitable network-addressable resource or website.

[0068] Application event data of a game is any data relevant to the game (e.g., player inputs). In particular embodiments, each application datum may have a name and a value, and the value of the application datum may change (i.e., be updated) at any time. When an update to an application datum occurs at client system 530, either caused by an action of a game player or by the game logic itself, client system 530 may need to inform game networking system 520b of the update. For example, if the game is a farming game with a harvest mechanic (such as Zynga FarmVille), an event can corre-

spond to a player clicking on a parcel of land to harvest a crop. In such an instance, the application event data may identify an event or action (e.g., harvest) and an object in the game to which the event or action applies. For illustration purposes and not by way of limitation, system 500 is discussed in reference to updating a multi-player online game hosted on a network-addressable system (such as, for example, social networking system 520a or game networking system 520b), where an instance of the online game is executed remotely on a client system 530, which then transmits application event data to the hosting system such that the remote game server synchronizes game state associated with the instance executed by the client system 530.

[0069] In a particular embodiment, one or more objects of a game may be represented as an Adobe Flash object. Flash may manipulate vector and raster graphics, and supports bi-directional streaming of audio and video. “Flash” may mean the authoring environment, the player, or the application files. In particular embodiments, client system 530 may include a Flash client. The Flash client may be configured to receive and run the Flash application or game object code from any suitable networking system (such as, for example, social networking system 520a or game networking system 520b). In particular embodiments, the Flash client may be run in a browser client executed on client system 530. A player can interact with Flash objects using client system 530 and the Flash client. The Flash objects can represent a variety of in-game objects. Thus, the player may perform various in-game actions on various in-game objects by making various changes and updates to the associated Flash objects. In particular embodiments, in-game actions can be initiated by clicking or similarly interacting with a Flash object that represents a particular in-game object. For example, a player can interact with a Flash object to use, move, rotate, delete, attack, shoot, or harvest an in-game object. This disclosure contemplates performing any suitable in-game action by interacting with any suitable Flash object. In particular embodiments, when the player makes a change to a Flash object representing an in-game object, the client-executed game logic may update one or more game state parameters associated with the in-game object. To ensure synchronization with the Flash object shown to the player at client system 530, the Flash client may send the events that caused the game state changes to the in-game object to game networking system 520b. However, to expedite the processing and hence the speed of the overall gaming experience, the Flash client may collect a batch of some number of events or updates into a batch file. The number of events or updates may be determined by the Flash client dynamically or determined by game networking system 520b based on server loads or other factors. For example, client system 530 may send a batch file to game networking system 520b whenever 50 updates have been collected or after a threshold period of time, such as every minute.

[0070] As used herein, the term “application event data” may refer to any data relevant to a computer-implemented game application that may affect one or more game state parameters, including, for example and without limitation, changes to player data or metadata, changes to player social connections or contacts, player inputs to the game, and events generated by the game logic. In particular embodiments, each application datum may have a name and a value. The value of an application datum may change at any time in response to the game play of a player or in response to the game engine (e.g., based on the game logic). In particular embodiments, an

application data update occurs when the value of a specific application datum is changed. In particular embodiments, each application event datum may include an action or event name and a value (such as an object identifier). Thus, each application datum may be represented as a name-value pair in the batch file. The batch file may include a collection of name-value pairs representing the application data that have been updated at client system 530. In particular embodiments, the batch file may be a text file, and the name-value pairs may be in string format.

[0071] In particular embodiments, when a player plays an online game on client system 530, game networking system 520b may serialize all the game-related data, including, for example and without limitation, game states, game events, and user inputs, for this particular user and this particular game into a BLOB and store the BLOB in a database. The BLOB may be associated with an identifier that indicates that the BLOB contains the serialized game-related data for a particular player and a particular online game. In particular embodiments, while a player is not playing the online game, the corresponding BLOB may be stored in the database. This enables a player to stop playing the game at any time without losing the current state of the game that the player is in. When a player resumes playing the game next time, game networking system 520b may retrieve the corresponding BLOB from the database to determine the most-recent values of the game-related data. In particular embodiments, while a player is playing the online game, game networking system 520b may also load the corresponding BLOB into a memory cache so that the game system may have faster access to the BLOB and the game-related data contained therein.

Systems and Methods

[0072] In particular embodiments, one or more described webpages may be associated with a networking system or networking service. However, alternate embodiments may have application to the retrieval and rendering of structured documents hosted by any type of network addressable resource or web site. Additionally, as used herein, a user may be an individual, a group, or an entity (such as a business or third party application).

[0073] Particular embodiments may operate in a wide area network environment, such as the Internet, including multiple network addressable systems. FIG. 10 illustrates an example network environment 600 in which various example embodiments may operate. Network cloud 660 generally represents one or more interconnected networks, over which the systems and hosts described herein can communicate. Network cloud 660 may include packet-based wide area networks (such as the Internet), private networks, wireless networks, satellite networks, cellular networks, paging networks, and the like. As FIG. 10 illustrates, particular embodiments may operate in a network environment comprising one or more networking systems, such as social networking system 620a, game networking system 620b, and one or more client systems 630. The components of social networking system 620a and game networking system 620b operate analogously; as such, hereinafter they may be referred to simply as networking system 620. Client systems 630 are operably connected to the network environment via a network service provider, a wireless carrier, or any other suitable means.

[0074] Networking system 620 is a network addressable system that, in various example embodiments, comprises one or more physical servers 622 and data stores 624. The one or

more physical servers **622** are operably connected to network cloud **660** via, by way of example, a set of routers and/or networking switches **626**. In an example embodiment, the functionality hosted by the one or more physical servers **122** may include web or HTTP servers, and FTP servers, as well as, without limitation, webpages and applications implemented using Common Gateway Interface (CGI) script, PHP Hyper-text Preprocessor (PHP), Active Server Pages (ASP), HTML, XML, Java, JavaScript, Asynchronous JavaScript and XML (AJAX), Flash, ActionScript, and the like.

[0075] Physical servers **622** may host functionality directed to the operations of networking system **620**. Hereinafter servers **622** may be referred to as server **622**, although server **622** may include numerous servers hosting, for example, networking system **620**, as well as other content distribution servers, data stores, and databases. Data store **624** may store content and data relating to, and enabling, operation of networking system **620** as digital data objects. A data object, in particular embodiments, is an item of digital information typically stored or embodied in a data file, database, or record. Content objects may take many forms, including: text (e.g., American Standard Code for Information Interchange (ASCII), Standard Generalized Markup Language (SGML), HTML), images (e.g., jpeg, tif and gif), graphics (vector-based or bitmap), audio, video (e.g., mpeg), or other multimedia, and combinations thereof. Content object data may also include executable code objects (e.g., games executable within a browser window or frame), podcasts, and so forth. Logically, data store **624** corresponds to one or more of a variety of separate and integrated databases, such as relational databases and object-oriented databases, that maintain information as an integrated collection of logically related records or files stored on one or more physical systems. Structurally, data store **624** may generally include one or more of a large class of data storage and management systems. In particular embodiments, data store **624** may be implemented by any suitable physical system(s) including components, such as one or more database servers, mass storage media, media library systems, storage area networks, data storage clouds, and the like. In one example embodiment, data store **624** includes one or more servers, databases (e.g., MySQL), and/or data warehouses. Data store **624** may include data associated with different networking system **620** users and/or client systems **630**.

[0076] Client system **630** is generally a computer or computing device including functionality for communicating (e.g., remotely) over a computer network. Client system **630** may be a desktop computer, laptop computer, personal digital assistant (PDA), in- or out-of-car navigation system, smart phone or other cellular or mobile phone, or mobile gaming device, among other suitable computing devices. Client system **630** may execute one or more client applications, such as a web browser, to access and view content over a computer network. In particular embodiments, the client applications allow a user of client system **630** to enter addresses of specific network resources to be retrieved, such as resources hosted by networking system **620**. These addresses can be Uniform Resource Locators (URLs) and the like. In addition, once a page or other resource has been retrieved, the client applications may provide access to other pages or records when the user “clicks” on hyperlinks to other resources. By way of example, such hyperlinks may be located within the webpages and provide an automated way for the user to enter the URL of another page and to retrieve that page.

[0077] A webpage or resource embedded within a webpage, which may itself include multiple embedded resources, may include data records, such as plain textual information, or more complex digitally encoded multimedia content, such as software programs or other code objects, graphics, images, audio signals, videos, and so forth. One prevalent markup language for creating webpages is HTML. Other common web browser-supported languages and technologies include XML, the Extensible Hypertext Markup Language (XHTML), JavaScript, Flash, ActionScript, Cascading Style Sheet (CSS), and, frequently, Java. By way of example, HTML enables a page developer to create a structured document by denoting structural semantics for text and links, as well as images, web applications, and other objects that can be embedded within the page. Generally, a webpage may be delivered to a client as a static document; however, through the use of web elements embedded in the page, an interactive experience may be achieved with the page or a sequence of pages. During a user session at the client, the web browser interprets and displays the pages and associated resources received or retrieved from the website hosting the page, as well as, potentially, resources from other websites.

[0078] When a user at a client system **630** desires to view a particular webpage (hereinafter also referred to as target structured document) hosted by networking system **620**, the user’s web browser, or other document rendering engine or suitable client application, formulates and transmits a request to networking system **620**. The request generally includes a URL or other document identifier as well as metadata or other information. By way of example, the request may include information identifying the user, such as a user ID, as well as information identifying or characterizing the web browser or operating system running on the user’s client computing device **630**. The request may also include location information identifying a geographic location of the user’s client system or a logical network location of the user’s client system. The request may also include a timestamp identifying when the request was transmitted.

[0079] Although the example network environment described above and illustrated in FIG. **10** described with respect to social networking system **620a** and game networking system **620b**, this disclosure encompasses any suitable network environment using any suitable systems. As an example and not by way of limitation, the network environment may include online media systems, online reviewing systems, online search engines, online advertising systems, or any combination of two or more such systems.

[0080] FIG. **11** illustrates an example computing system architecture, which may be used to implement a server **622** or a client system **630**. In one embodiment, hardware system **700** comprises a processor **702**, a cache memory **704**, and one or more executable modules and drivers, stored on a tangible computer readable medium, and directed to the functions described herein. Additionally, hardware system **700** may include a high performance input/output (I/O) bus **706** and a standard I/O bus **708**. A host bridge **710** may couple processor **702** to high performance I/O bus **706**, whereas I/O bus bridge **712** couples the two buses **706** and **708** to each other. A system memory **714** and one or more network/communication interfaces **716** may couple to bus **706**. Hardware system **700** may further include video memory (not shown) and a display device coupled to the video memory. Mass storage **718** and I/O ports **720** may couple to bus **708**. Hardware system **700** may optionally include a keyboard, a pointing

device, and a display device (not shown) coupled to bus **708**. Collectively, these elements are intended to represent a broad category of computer hardware systems, including but not limited to general purpose computer systems based on the x86-compatible processors manufactured by Intel Corporation of Santa Clara, Calif., and the x86-compatible processors manufactured by Advanced Micro Devices (AMD), Inc., of Sunnyvale, Calif., as well as any other suitable processor.

[0081] The elements of hardware system **700** are described in greater detail below. In particular, network interface **716** provides communication between hardware system **700** and any of a wide range of networks, such as an Ethernet (e.g., IEEE 802.3) network, a backplane, and so forth. Mass storage **718** provides permanent storage for the data and programming instructions to perform the above-described functions implemented in servers **622**, whereas system memory **714** (e.g., DRAM) provides temporary storage for the data and programming instructions when executed by processor **702**. I/O ports **720** are one or more serial and/or parallel communication ports that provide communication between additional peripheral devices, which may be coupled to hardware system **700**.

[0082] Hardware system **700** may include a variety of system architectures, and various components of hardware system **700** may be rearranged. For example, cache **704** may be on-chip with processor **702**. Alternatively, cache **704** and processor **702** may be packed together as a “processor module,” with processor **702** being referred to as the “processor core.” Furthermore, certain embodiments of the present disclosure may not require nor include all of the above components. For example, the peripheral devices shown coupled to standard I/O bus **708** may couple to high performance I/O bus **706**. In addition, in some embodiments, only a single bus may exist, with the components of hardware system **700** being coupled to the single bus. Furthermore, hardware system **700** may include additional components, such as additional processors, storage devices, or memories.

[0083] An operating system manages and controls the operation of hardware system **700**, including the input and output of data to and from software applications (not shown). The operating system provides an interface between the software applications being executed on the system and the hardware components of the system. Any suitable operating system may be used, such as the LINUX Operating System, the Apple Macintosh Operating System, available from Apple Computer Inc. of Cupertino, Calif., UNIX operating systems, Microsoft(r) Windows(r) operating systems, Berkeley Software Distribution (BSD) operating systems, and the like. Of course, other embodiments are possible. For example, the functions described herein may be implemented in firmware or on an application-specific integrated circuit.

[0084] Furthermore, the above-described elements and operations can be comprised of instructions that are stored on non-transitory storage media. The instructions can be retrieved and executed by a processing system. Some examples of instructions are software, program code, and firmware. Some examples of non-transitory storage media are memory devices, tapes, disks, integrated circuits, and servers. The instructions are operational when executed by the processing system to direct the processing system to operate in accordance with the disclosure. The term “processing system” refers to a single processing device or a group of inter-operational processing devices. Some examples of process-

ing devices are integrated circuits and logic circuitry. Those skilled in the art are familiar with instructions, computers, and storage media.

Conclusion

[0085] Although only certain embodiments have been described in detail above, those skilled in the art will readily appreciate that many modifications are possible without materially departing from the novel teachings of this disclosure. For example, aspects of embodiments disclosed above can be combined in other combinations to form additional embodiments. Accordingly, all such modifications are intended to be included within the scope of this disclosure.

[0086] A recitation of “a”, “an,” or “the” is intended to mean “one or more” unless specifically indicated to the contrary. In addition, it is to be understood that functional operations, such as “awarding,” “locating,” “permitting,” and the like, are executed by game application logic that accesses, and/or causes changes to, various data attribute values maintained in a database or other memory. Unless specifically indicated to the contrary, ordinal identifiers such as “first” and “second” are used herein for labeling purposes only and are not intended to denote any specific spatial or temporal ordering. Furthermore, the labeling of a “first” element does not imply the presence of a “second” element.

[0087] The present disclosure encompasses all changes, substitutions, variations, alterations, and modifications to the example embodiments herein that a person having ordinary skill in the art would comprehend. Similarly, where appropriate, the appended claims encompass all changes, substitutions, variations, alterations, and modifications to the example embodiments herein that a person having ordinary skill in the art would comprehend.

[0088] For example, the methods, game features and game mechanics described herein may be implemented using hardware components, software components, and/or any combination thereof. By way of example, while embodiments of the present disclosure have been described as operating in connection with a networking website, various embodiments of the present disclosure can be used in connection with any communications facility that supports web applications. Furthermore, in some embodiments the term “web service” and “website” may be used interchangeably and additionally may refer to a custom or generalized Application Programming Interface (API) on a device, such as a mobile device (e.g., cellular phone, smart phone, personal Global Positioning System (GPS), PDA, personal gaming device, etc.), that makes API calls directly to a server. The specification and drawings are, accordingly, to be regarded in an illustrative rather than a restrictive sense. It will, however, be evident that various modifications and changes may be made thereunto without departing from the broader spirit and scope of the disclosure as set forth in the claims and that the disclosure is intended to cover all modifications and equivalents within the scope of the following claims.

1. A method of matching players in an online asynchronous game where players specify moves at different times, comprising:

receiving values for a plurality of moves corresponding to a plurality of users playing in instances of the online asynchronous game, the online asynchronous game being hosted by a computer system that stores online-game values in a data storage system;

using at least one computer to determine gameplay characteristics of the users from the moves, the gameplay characteristics for a user including at least one of a playing frequency that characterizes how frequently the user engages in the online asynchronous game, a playing intensity that characterizes simultaneous instances played by the user in the online asynchronous game or a playing style that characterizes repeated move patterns by the user in the online asynchronous game;

matching a first user and a second user to play a selected instance of the online asynchronous game by comparing their corresponding gameplay characteristics;

receiving values corresponding to the selected instance of the online asynchronous game as played by the first user and the second user; and

determining an engagement value based on the gameplay characteristics for at least one of the first user or the second user from the values corresponding to the selected instance of the online asynchronous game, the engagement value characterizing a change in the gameplay characteristics relative to the gameplay characteristics before the matching of the first user and the second user.

2. The method of claim 1, wherein the gameplay characteristics are determined by using values from the moves to identify gameplay patterns of the moves over time.

3. The method of claim 1, wherein the engagement value characterizes a change in the first user's playing frequency relative to the first user's playing frequency before the matching of the first user and the second user, the first user's playing frequency being characterized by calculating a value for how often the first user plays the online asynchronous game with respect to a reference time zone.

4. The method of claim 1, wherein the engagement value characterizes a change in the first user's playing frequency relative to the first user's playing frequency before the matching of the first user and the second user, the first user's playing frequency being characterized by calculating a value for an amount of time that the first user waits in the online asynchronous game before responding to another player.

5. The method of claim 1, wherein the engagement value characterizes a change in the first user's playing intensity relative to the first user's playing intensity before the matching of the first user and the second user, the first user's playing intensity being characterized by calculating a value for a number of instances of the online asynchronous game being simultaneously played by the first user.

6. The method of claim 1, wherein the engagement value characterizes a change in the first user's playing style relative to the first user's playing style before the matching of the first user and the second user, the first user's playing style being characterized by calculating one or more values for how often that user employs selected move patterns in the online asynchronous game.

7. The method of claim 1, wherein an instance of the online asynchronous game includes a plurality of rounds in which players specify moves at different times in each round before a common deadline in that round.

8. The method of claim 1, wherein an instance of the online asynchronous game includes a plurality of rounds in which players specify moves at different times by alternating moves at different times.

9. The method of claim 1, further comprising classifying each user into one of a plurality of groups that each corre-

spond to a different range of gameplay values for a measure of gameplay characteristics, wherein the matching of the first user and the second user includes:

- selecting the first user from a first group with a first gameplay-value range, and
- selecting the second user from a second group with a second gameplay-value range that is a threshold distance from the first gameplay-value range.

10. The method of claim 1, wherein the gameplay characteristics are determined from values of the moves.

11. A non-transitory computer-readable medium that stores a computer program for matching players in an online asynchronous game where players alternate moves at different times, the computer program including instructions that, when executed by at least one computer, cause the at least one computer to perform operations comprising:

- receiving values for a plurality of moves corresponding to a plurality of users playing in instances of the online asynchronous game, the online asynchronous game being hosted by a computer system that stores online-game values in a data storage system;

determining gameplay characteristics of the users from the moves, the gameplay characteristics for a user including at least one of a playing frequency that characterizes how frequently the user engages in the online asynchronous game, a playing intensity that characterizes simultaneous instances played by the user in the online asynchronous game or a playing style that characterizes repeated move patterns by the user in the online asynchronous game;

matching a first user and a second user to play a selected instance of the online asynchronous game by comparing their corresponding gameplay characteristics;

receiving values corresponding to the selected instance of the online asynchronous game as played by the first user and the second user; and

determining an engagement value based on the gameplay characteristics for at least one of the first user or the second user from the values corresponding to the selected instance of the online asynchronous game, the engagement value characterizing a change in the gameplay characteristics relative to the gameplay characteristics before the matching of the first user and the second user.

12. The non-transitory computer-readable medium of claim 11, wherein the gameplay characteristics are determined by using values from the moves to identify gameplay patterns of the moves over time.

13. The non-transitory computer-readable medium of claim 11, wherein the engagement value characterizes a change in the first user's playing frequency relative to the first user's playing frequency before the matching of the first user and the second user, the first user's playing frequency being characterized by calculating a value for how often the first user plays the online asynchronous game with respect to a reference time zone.

14. The non-transitory computer-readable medium of claim 11, wherein the engagement value characterizes a change in the first user's playing frequency relative to the first user's playing frequency before the matching of the first user and the second user, the first user's playing frequency being characterized by calculating a value for an amount of time that the first user waits in the online asynchronous game before responding to another player.

15. The non-transitory computer-readable medium of claim 11, wherein the engagement value characterizes a change in the first user's playing intensity relative to the first user's playing intensity before the matching of the first user and the second user, the first user's playing intensity being characterized by calculating a value for a number of instances of the online asynchronous game being simultaneously played by the first user.

16. The non-transitory computer-readable medium of claim 11, wherein the engagement value characterizes a change in the first user's playing style relative to the first user's playing style before the matching of the first user and the second user, the first user's playing style being characterized by calculating one or more values for how often that user employs selected move patterns in the online asynchronous game.

17. The non-transitory computer-readable medium of claim 11, wherein an instance of the online asynchronous game includes a plurality of rounds in which players specify moves at different times in each round before a common deadline in that round.

18. The non-transitory computer-readable medium of claim 11, wherein an instance of the online asynchronous game includes a plurality of rounds in which players specify moves at different times by alternating moves at different times.

19. The non-transitory computer-readable medium of claim 11, wherein the computer program further includes instructions that, when executed by the at least one computer, cause the at least one computer to perform operations comprising:

- classifying each user into one of a plurality of groups that each correspond to a different range of gameplay values for a measure of gameplay characteristics, wherein the matching of the first user and the second user includes: selecting the first user from a first group with a first gameplay-value range, and
- selecting the second user from a second group with a second gameplay-value range that is a threshold distance from the first gameplay-value range.

20. An apparatus to match players in an online asynchronous game where players alternate moves at different times, the apparatus comprising at least one computer to perform operations for computer-executable modules including:

- a value-receiving module configured to receive values for a plurality of moves corresponding to a plurality of users playing in instances of the online asynchronous game;
- a gameplay-characteristics module configured to determine gameplay characteristics of the users from the moves, the gameplay characteristics for a user including at least one of a playing frequency that characterizes how frequently the user engages in the online asynchronous game, a playing intensity that characterizes simultaneous instances played by the user in the online asynchronous game or a playing style that characterizes repeated move patterns by the user in the online asynchronous game; and

a user-matching module configured to match a first user and a second user to play a selected instance of the online asynchronous game by comparing their corresponding gameplay characteristics, the user-matching module further operating to receive values corresponding to the

selected instance of the online asynchronous game as played by the first user and the second user, and the user-matching module further operating to determine an engagement value based on the gameplay characteristics for at least one of the first user or the second user from the values corresponding to the selected instance of the online asynchronous game, the engagement value characterizing a change in the gameplay characteristics relative to the gameplay characteristics before the matching of the first user and the second user.

21. The apparatus of claim 20, wherein the gameplay characteristics are determined by using values from the moves to identify gameplay patterns of the moves over time.

22. The apparatus of claim 20, wherein the engagement value characterizes a change in the first user's playing frequency relative to the first user's playing frequency before the matching of the first user and the second user, the first user's playing frequency being characterized by calculating a value for how often the first user plays the online asynchronous game with respect to a reference time zone.

23. The apparatus of claim 20, wherein the engagement value characterizes a change in the first user's playing frequency relative to the first user's playing frequency before the matching of the first user and the second user, the first user's playing frequency being characterized by calculating a value for an amount of time that the first user waits in the online asynchronous game before responding to another player.

24. The apparatus of claim 20, wherein the engagement value characterizes a change in the first user's playing intensity relative to the first user's playing intensity before the matching of the first user and the second user, the first user's playing intensity being characterized by calculating a value for a number of instances of the online asynchronous game being simultaneously played by the first user.

25. The apparatus of claim 20, wherein the engagement value characterizes a change in the first user's playing style relative to the first user's playing style before the matching of the first user and the second user, the first user's playing style being characterized by calculating one or more values for how often that user employs selected move patterns in the online asynchronous game.

26. The apparatus of claim 20, wherein an instance of the online asynchronous game includes a plurality of rounds in which players specify moves at different times in each round before a common deadline in that round.

27. The apparatus of claim 20, wherein an instance of the online asynchronous game includes a plurality of rounds in which players specify moves at different times by alternating moves at different times.

28. The apparatus of claim 20, wherein the user-matching module is further configured to perform operations including: classifying each user into one of a plurality of groups that each correspond to a different range of gameplay values for a measure of gameplay characteristics, wherein the matching of the first user and the second user includes: selecting the first user from a first group with a first gameplay-value range, and selecting the second user from a second group with a second gameplay-value range that is a threshold distance from the first gameplay-value range.