

[54] **NON-ROUND FLUID DYNAMOMETER**
 [75] Inventor: **Joachim C. Bronder**, Trumbull, Conn.
 [73] Assignee: **Avco Corporation**, Stratford, Conn.
 [22] Filed: **Sept. 17, 1971**
 [21] Appl. No.: **181,358**

3,598,208 8/1971 Bronder188/290
 3,618,377 11/1971 Barker.....73/134

Primary Examiner—Charles A. Ruehl
Attorney—Charles M. Hogan et al.

[52] U.S. Cl.....73/134, 188/290
 [51] Int. Cl.....G011 3/20
 [58] Field of Search73/134; 188/290, 296

[57] **ABSTRACT**

The operating characteristics of an otherwise conventional fluid dynamometer are improved by supporting the rotor and stator disks within a housing having a cross section which is non-round. The use of the non-round housing causes a change in direction of motion of the fluids within the dynamometer, thereby preventing the formation of a solid rotating core of fluid.

[56] **References Cited**

UNITED STATES PATENTS

2,727,594 12/1955 Ganster, Jr.....188/296

6 Claims, 2 Drawing Figures

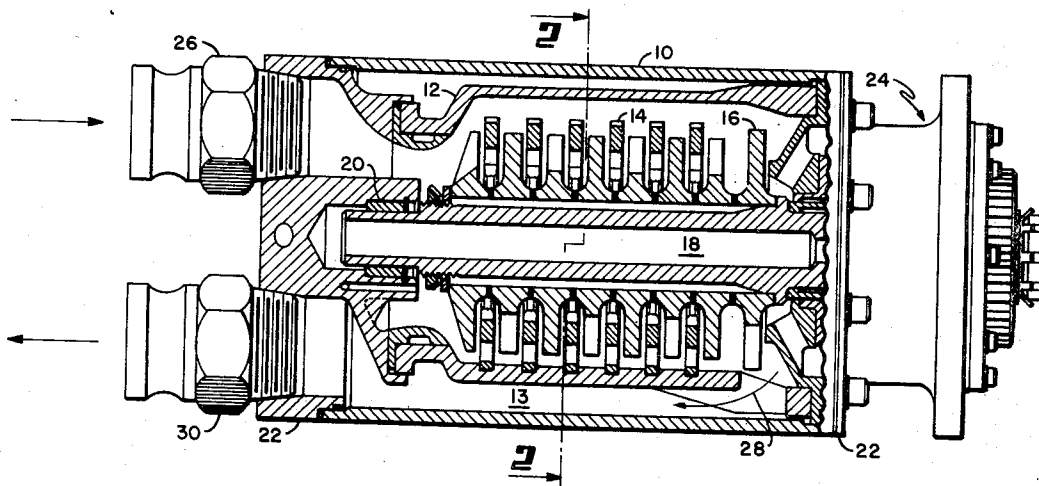

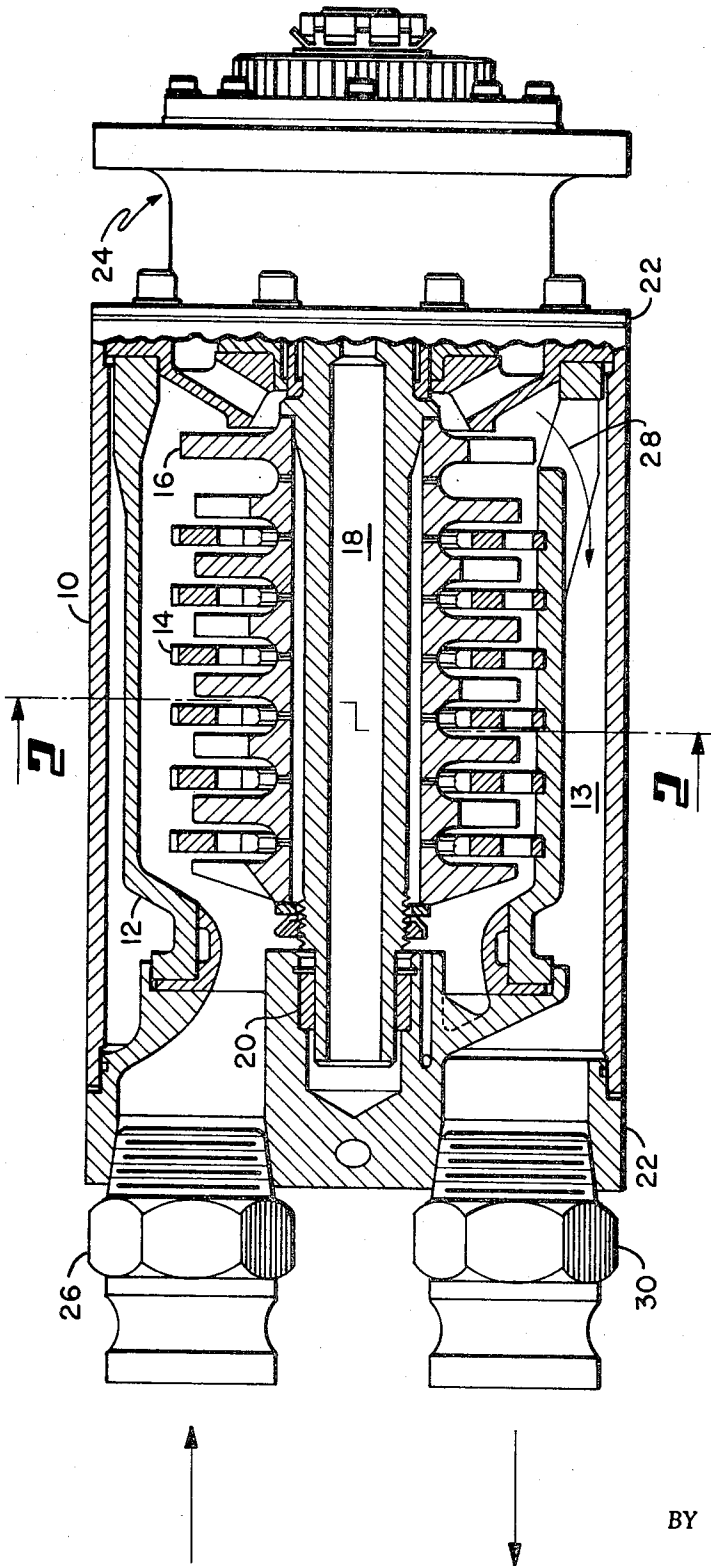
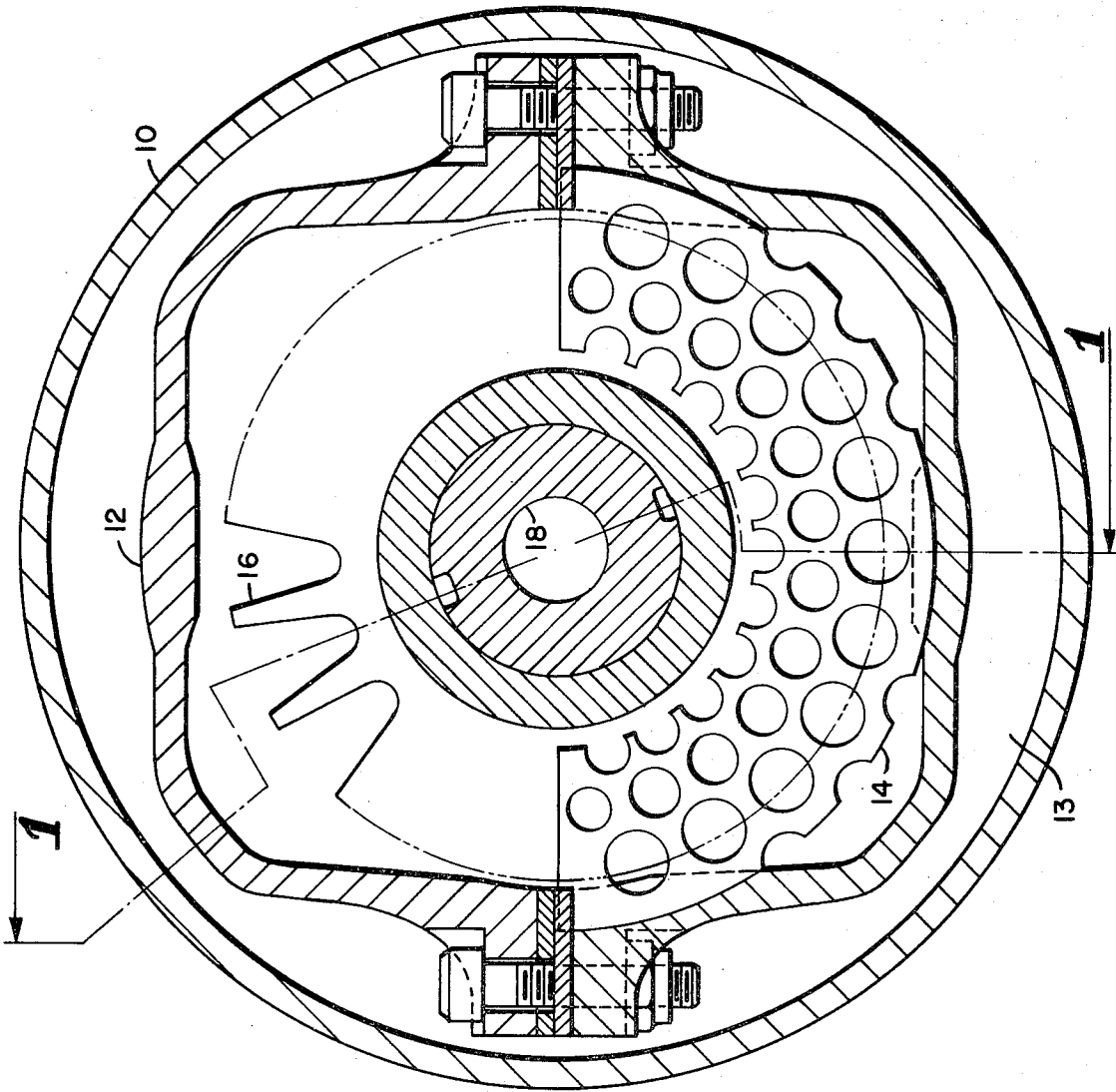

Fig 1

INVENTOR.
JOACHIM C. BRONDER
BY *Charles M. Hogan*
Kevin P. Campbell
ATTORNEYS.



Hi-Q

INVENTOR.
JOACHIM C. BRONDER

BY *Charles M. Hogan*
John P. Conforte
ATTORNEYS.

NON-ROUND FLUID DYNAMOMETER**BACKGROUND OF THE INVENTION**

This invention relates to a novel fluid dynamometer which uses a non-round stator housing within which the rotor is mounted, and is particularly concerned with water dynamometers. In general, water dynamometers comprise a stator and a rotor with restricted fluid passages therebetween, the stator being supported within a housing having a circular inner cross section. The rotor is driven by a device under test, and upon the introduction of the fluid into the housing the fluid absorbs the energy, and hence the rotor presents a torque to the device under test. In all of the known prior art water dynamometers there are many inherent problems. These include high frequency vibratory conditions at various speeds and excessive cavitation. Such conditions limit the range of operability of the dynamometer and also tend to adversely affect its useful life.

THE IMPROVEMENT

The present invention is an improvement over the known prior art fluid dynamometers in that it provides a non-round inner housing geometry. This geometry provides a changing radial distance between the inner wall and the axis of rotation, thereby preventing the formation of a uniformly rotating fluid core. The non-round housing serves to redirect the fluid mass so as to generate forces that result in high torque absorption for a given water dynamometer rotor, less fluctuation of absorbed torque, a better mixture of the working fluid, and an increase in the useful range of operational torque.

The primary object of this invention is to provide an improved fluid dynamometer having a non-round inner housing geometry.

Another object of this invention is to provide a fluid dynamometer having an inner housing geometry which has a polygonal cross section.

THE DRAWINGS

A representative embodiment of this invention is described in the following specification and is illustrated in the accompanying drawings in which:

FIG. 1 shows a cross section of a water dynamometer taken through the line 1—1 in FIG. 2; and

FIG. 2 is a cross section taken through the line 2—2 in FIG. 1.

DESCRIPTION OF THE ILLUSTRATED EMBODIMENT

Referring to the drawings, the illustrated fluid dynamometer is a water brake having an outer cylindrical housing 10 and a non-round inner housing 12 positioned within the cylindrical housing secured in fixed space thereto, the space between the housing forming a chamber 13. The non-round inner housing 12 supports a plurality of conventional apertured stator disks 14 between which are interleaved a plurality of apertured rotor disks 16. The rotor disks 16 are fixed to a rotatable shaft 18 supported at both ends in bearings 20. (The bearings at only one end are shown.) The inner housing 12 is non-round in its cross section taken in a plane perpendicular to the axis of the shaft 18. The

bearings and their retainers are suitably secured to the formed end closure walls 22 which serve to seal both ends of the outer housing 10. The shaft 18 is adapted to be driven through a conventional coupling 24 by a device under test (not shown). Water is admitted to the inner housing through an inlet 26. It is exhausted from the non-round inner housing 12 to the chamber 13 through apertures 28 and is exhausted from the chamber 13 through an outlet 30.

In use, a device to be tested mechanically is coupled to the shaft 18 by means of coupling 24. Simultaneously water is admitted to the interior of the inner housing through the inlet 26 where it is acted upon by the rotors 16 so that the water absorbs energy in the form of heat. The hot water is then exhausted through a number of ports 28 into the chamber 13 between the inner and outer housings and is exhausted through the outlet 30.

Because of the fact that the inner housing 12 is not cylindrical, the radial distance between the axis of the shaft 18 and the inner surfaces of the inner housing 12 are a function of angular position. This means that as the rotor is rotated the tendency of the water to rotatively follow the rotor is prevented since the direction of movement of the water is radially changed. The action on the water between the rotor and the inner housing causes a breaking up of any water layer that may form because of generation of higher turbulence. In addition, because of the change of mass flow direction, there is a general increase in the power absorption capability of the device and a better distribution of the power absorption throughout the brake.

While the illustrated embodiment shows a water dynamometer having an inner cross section which is substantially square, it will be understood that other non-round inner cross sections may also be advantageous. For example, the cross section may be rectangular or elliptical or it may be a polygon having a greater or lesser number of sides.

Claim 1 (Amended).

1. A fluid dynamometer comprising:
 - a rotatable shaft supported for rotation within said housing;
 - a plurality of axially spaced rotor disks secured to said shaft;
 - a plurality of axially spaced stator disks interleaved with said rotor disks, said stator disks being fixedly supported from said housing, the radial distance from the axis of said shaft to the periphery of the cross section of said [inner] housing taken in a plane perpendicular to said shaft being non-uniform;
 - inlet means for admitting [water] fluid to said housing; and
 - means for exhausting [water] fluid from said housing.
2. The invention as defined in claim 1 wherein said housing is non-round.
3. The invention as defined in claim 2 wherein said non-round housing is a polygon.
4. The invention as defined in claim 2 wherein said non-round housing is a four-sided polygon.
5. The invention as defined in claim 2 wherein said non-round housing is an inner housing, and wherein said fluid dynamometer further comprises an outer

3

housing, said non-round inner housing being supported within said outer housing in spaced relationship thereto, the space between said inner housing and said outer housing providing said fluid outlet means.

4

6. The invention as defined in claim 5 wherein the cross section of said outer housing taken through a plane perpendicular to said shaft is circular.

* * * * *

5

10

15

20

25

30

35

40

45

50

55

60

65