

No. 783,023.

PATENTED FEB. 21, 1905.

M. D. CONVERSE.
SCREW DRIVER.

APPLICATION FILED DEC. 31, 1903.

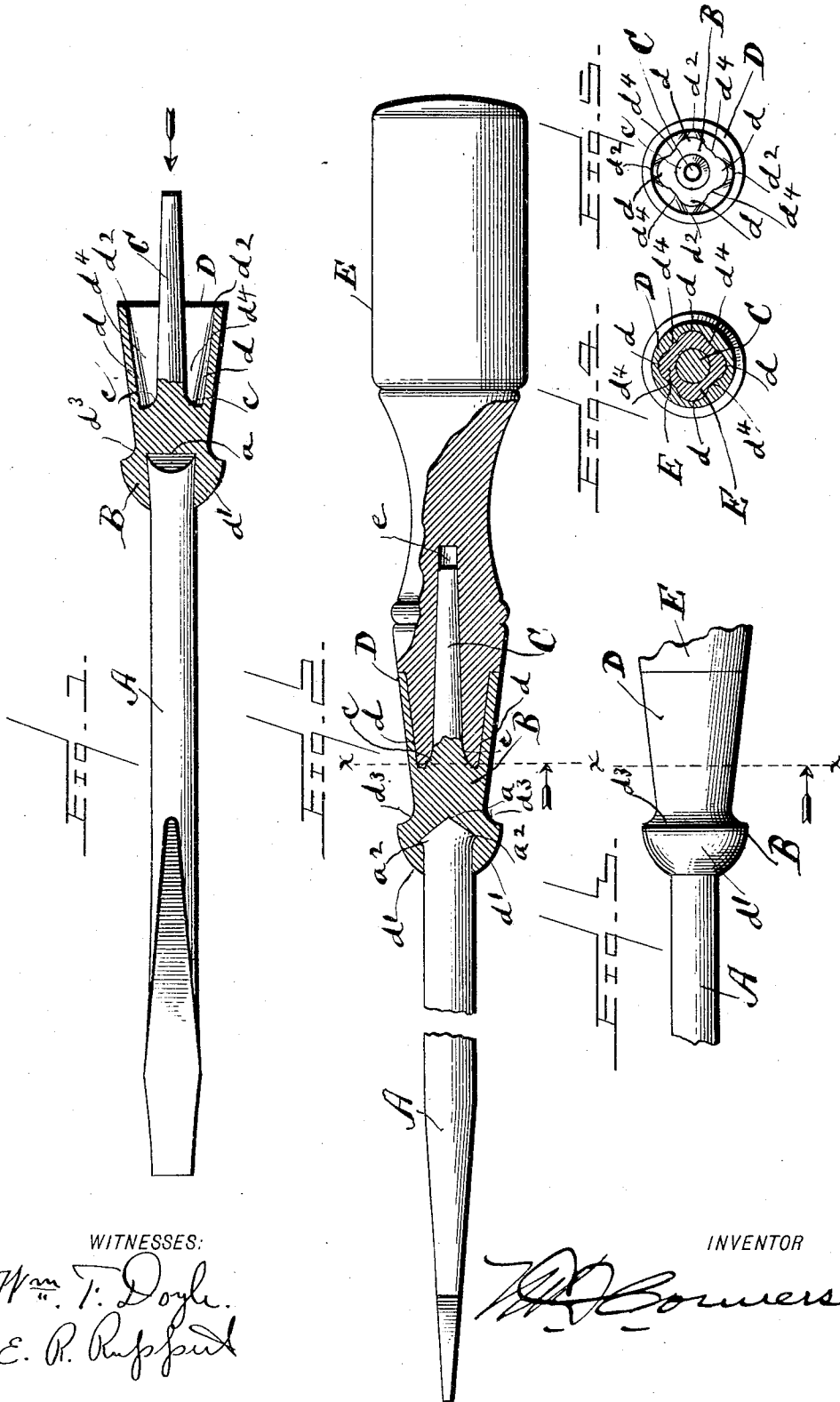

WITNESSES:

Wm. T. Doyle.
E. P. Ruppert

INVENTOR

M. D. Converse

UNITED STATES PATENT OFFICE.

MASCHIL D. CONVERSE, OF NEWARK, NEW JERSEY.

SCREW-DRIVER.

SPECIFICATION forming part of Letters Patent No. 783,023, dated February 21, 1905.

Application filed December 31, 1903. Serial No. 187,271.

To all whom it may concern:

Be it known that I, MASCHIL D. CONVERSE, a citizen of the United States, residing at Newark, in the county of Essex and State of New Jersey, have invented new and useful Improvements in Screw-Drivers, of which the following is a specification.

My invention relates to screw-drivers, and more definitely to means for uniting the blades to the bolsters and ferrules and securing the handles in the latter.

My invention is comprised in certain novel forms, construction, and combination of parts, the objects of which are to provide reliable devices for the purposes stated and to cheapen the cost of manufacture, all which will hereinafter be fully described and claimed.

In the drawings, Figure 1 is a side elevation, partly sectional, of my improved screw-driver without the handle. Fig. 2 is a quarter-turn side elevation of the same, partly sectional, with the handle in place. Fig. 3 is a side elevation in full of the bolster and ferrule, blade and handle partly broken away. Fig. 4 is a cross-section on line $x-x$ of Figs. 2 and 3, and Fig. 5 is an end view of the ferrule and bolster-tang with the handle removed looking into the former in the direction indicated by arrow in Fig. 1.

The several figures will now be described in detail, like letters of reference throughout the same indicating corresponding parts.

A is a blade of my improved screw-driver, which having been cut to required length at a by V-tools is slightly upset or enlarged in diameter thereby at the base a^2 of the bevels on opposite sides.

B is the bolster; C, the bolster-tang extending centrally therefrom outwardly and considerably beyond the open end of the ferrule D. The tang is preferably made tapered toward the outer end, as shown, and its base or juncture with the bolster is filleted or thickened at c . These three parts—bolster, bolster-tang, and ferrule—are made integral of cast metal, usually gray iron. The bolster B is preferably terminated in front to hemispherical form d' and reduced at d^3 rearward thereof to form a neck with lines meeting neatly the taper of the ferrule D. The interior of the

ferrule is constructed or cast with depressions $d-d$ radially, forming preferably a quatrefoil socket for the handle E. These depressions, starting at d^2 , are gradually deepened to the bottom of the socket. The handle is before being driven into the ferrule provided with a hole e for reception of the tang C.

The operation of my invention is as follows: The blade A, having been cut and formed, as shown, with the upsetting or enlargement a^2 , is by methods and means well known to metal molders fixed in the bolster B by casting of the latter thereon and by reason of the enlargement a^2 and the bevels at the end a can now neither come out of or turn in the bolster when the screw-driver is being used, since in this process of casting the metal of the bolster closely contacts with, conforms to the shape, and contracts upon the shank end of the blade and, if necessary, can be made to slightly fuse therewith. The bolster, bolster-tang, and ferrule having been formed as shown, the handle, with a properly-dimensioned socket end and hole e , is forced into the socket of the ferrule, and as this is done the tapered tang C and its thickened or filleted base c force the fiber of the handle with great pressure radially into the depressions d , where it is further compressed and kept from splitting by the divisions or ridges d^4 between the depressions, which then prevent the handle from turning or becoming loosened in the socket when the screw-driver is being used.

In practice the tang-hole e in the handle is bored straight with a uniform diameter about equal to the diameter of the tang at a point midway its length, and the end of the handle to enter the ferrule-socket is made with a taper corresponding to that of the dividing-ridges d^4 and with a diameter slightly greater than the internal diametral measurement of the same.

The bolster-tang C and the tang-hole e in the handle may be dispensed with entirely provided the manifoliations $d-d$ in the handle-socket of the ferrule are retained.

Manifestly the novel construction of the blade-shank herein described may be employed for the purposes shown in connection with forms of ferrules other than those herein de-

scribed without departing from the spirit of this part of my invention. Likewise the novel construction of ferrules or of ferrule and bolster-tang herein described may be employed
 5 in connection with forms of screw-driver shanks other than that described herein without departing from the spirit of this part of my invention. Furthermore, the upsetting or enlargement of the end of the shank may
 10 be made in modified form and by a different method or means to serve the same purposes without departing from the spirit of this part of my invention.

Having described my invention, what I
 15 claim as new, and desire to secure by Letters Patent, is—

1. In a screw-driver a blade having its shank end beveled, in combination with a metal bolster molded or cast thereon.
- 20 2. In a screw-driver a blade having its shank end beveled and upset or enlarged at the base of the bevel, in combination with a metal bolster molded or cast thereon.
3. In a screw-driver a metal bolster, tapered
 25 tang and ferrule integrally cast or molded, said ferrule having depressions in the interior and said tapered bolster-tang having a thickened or filleted base for the purposes shown and described, in combination with a suitably
 30 shaped and bored handle.
4. In a screw-driver a bolster, tapered bolster-tang and ferrule integrally cast or molded,

said ferrule having a quatrefoil handle-socket, and said tapered bolster-tang having a thickened or filleted base for the purposes
 35 shown and described in combination with a suitably shaped and bored handle.

5. In a screw-driver a blade having an enlargement at its shank end adapted to fix it securely against turning in, or coming out of,
 40 a metal bolster cast or molded thereon, a bolster, tapered bolster-tang and ferrule integrally cast or molded, said ferrule having depressions in the interior and said tapered bolster-tang having a thickened or filleted base
 45 for the purposes shown and described, in combination with a suitably shaped and bored handle.

6. In a screw-driver a blade having its shank end beveled and upset or enlarged at the base
 50 of the bevel, a metal bolster, tapered bolster-tang and ferrule integrally cast or molded thereon, said ferrule having a quatrefoil handle-socket, and said tapered bolster-tang having a thickened or filleted base for the purposes
 55 shown and described, in combination with a suitably shaped and bored handle.

In testimony whereof I have signed my name to this specification in the presence of two subscribing witnesses.

MASCHIL D. CONVERSE.

Witnesses:

JNO. T. MEANY,

GUY E. CRAMPTON.