

D. S. WHITE.

COMBINED HEATING AND VENTILATING APPARATUS.

No. 545,113.

Patented Aug. 27, 1895.

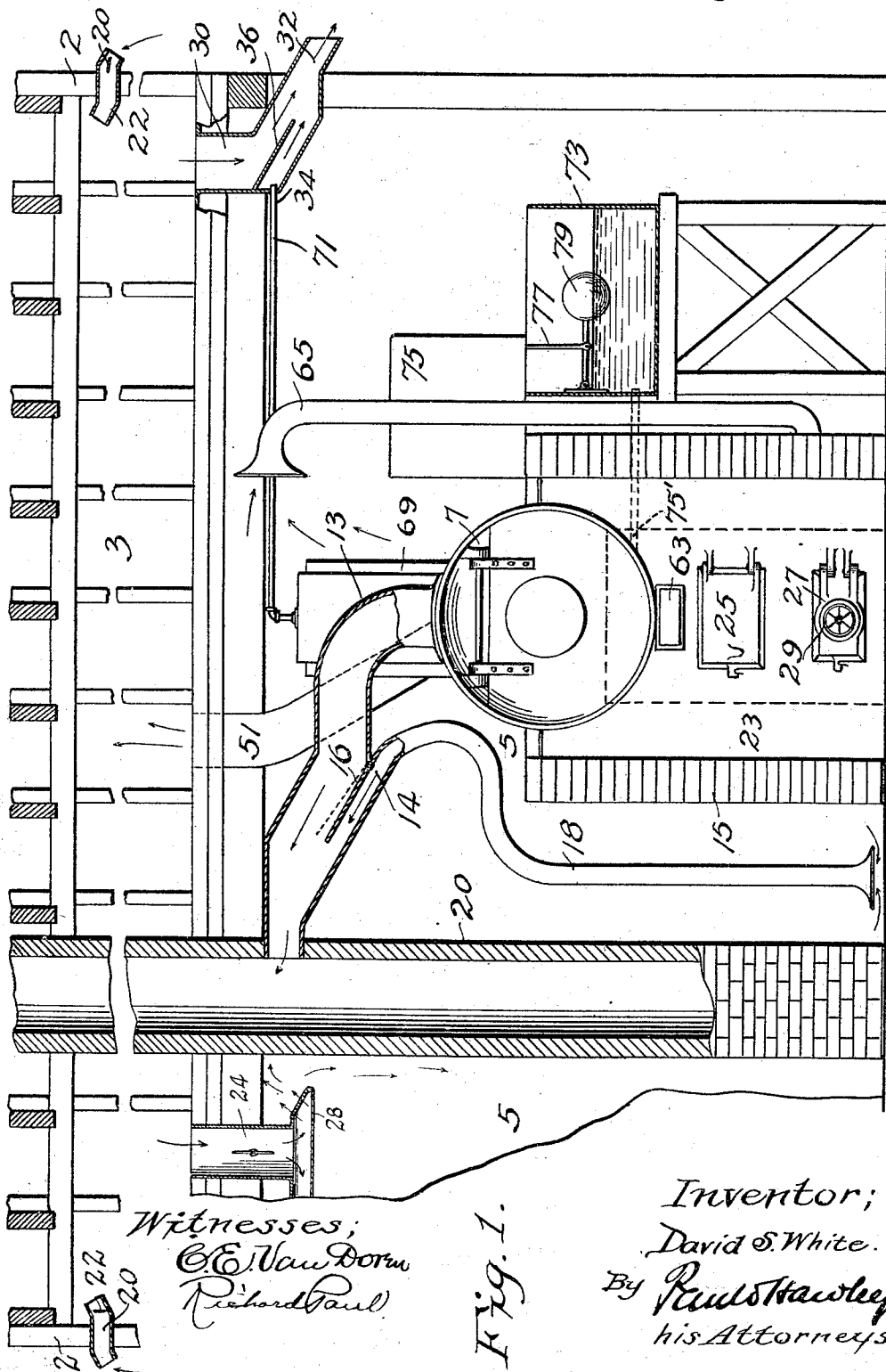

Witnesses;
E. N. Dowd
Richard Paul

Fig. 1.

Inventor;
David S. White.
 By *Paul Hawley*
his Attorneys.

D. S. WHITE.

COMBINED HEATING AND VENTILATING APPARATUS.

No. 545,113.

Patented Aug. 27, 1895.

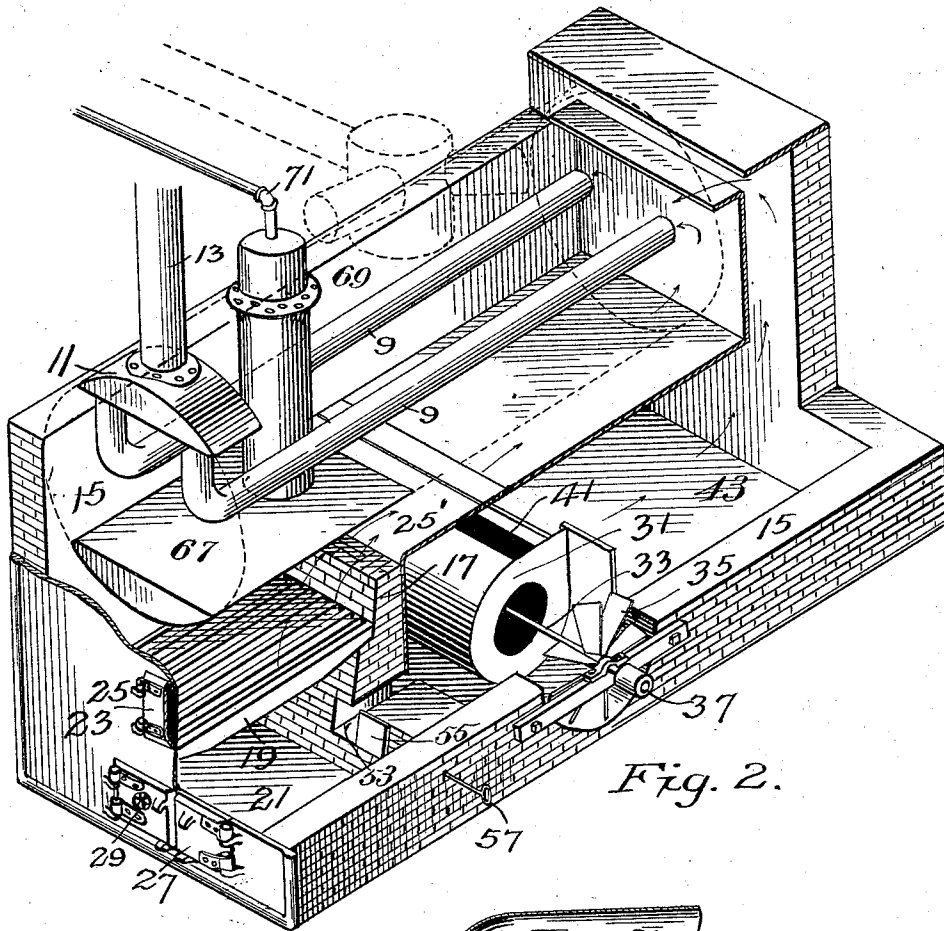

Fig. 2.

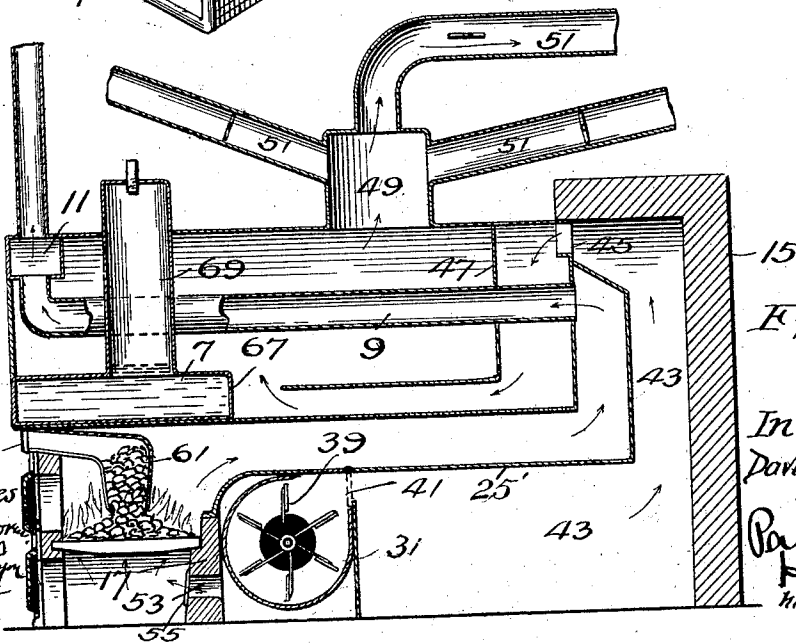

Fig. 3.

Inventor:
David S. White
By
Paul H. Heavly
his Att'y.

Witnesses
C. E. Van Doren
Frederick A. ...

(No Model.)

3 Sheets—Sheet 3

D. S. WHITE.

COMBINED HEATING AND VENTILATING APPARATUS.

No. 545,113.

Patented Aug. 27, 1895.

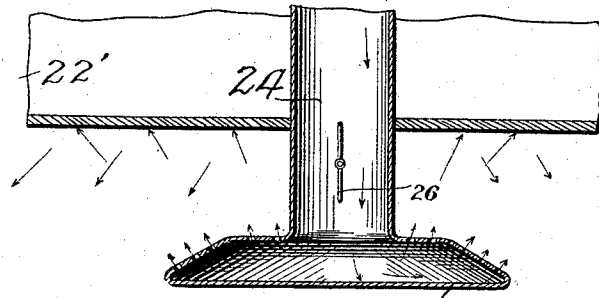
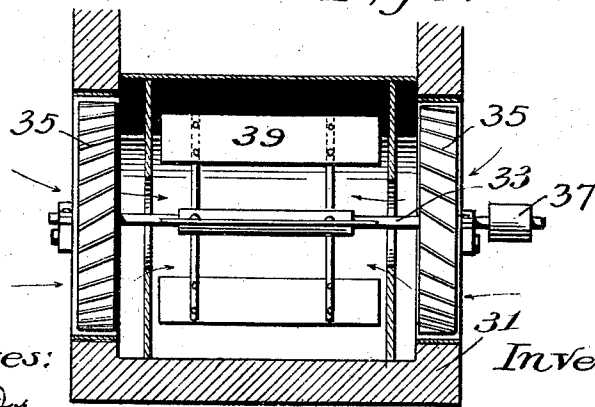

Fig. 4. 28



Witnesses:

C. E. Van Doren,
Frederick S. Lyon

Inventor:

David S. White.

Fig. 5.

By *Paul & Hawley*
 his Attorneys.

UNITED STATES PATENT OFFICE.

DAVID S. WHITE, OF NORTHFIELD, MINNESOTA.

COMBINED HEATING AND VENTILATING APPARATUS.

SPECIFICATION forming part of Letters Patent No. 545,113, dated August 27, 1895.

Application filed June 21, 1894. Serial No. 515,322. (No model.)

To all whom it may concern:

Be it known that I, DAVID S. WHITE, of Northfield, in the county of Rice and State of Minnesota, have invented a certain new and improved Combined Heating and Ventilating Apparatus, of which the following is a specification.

This invention relates to improvements in combination heating and ventilating apparatus, and the object which I have in view is especially to provide a combined hot-air and steam heating apparatus especially adapted for private dwellings, having a suitable ventilating apparatus combined therewith.

Other objects of the invention will be understood from the following detailed description, taken in connection with the accompanying drawings, in which—

Figure 1 is a front elevation of a heating apparatus embodying my invention, showing the chimney in partial section and the heating-pipe leading to the room above. Fig. 2 is a perspective view of the heater proper, the deflecting-plate 47 and the self-feeding reservoir being omitted in order that the other parts may be more clearly illustrated. Fig. 3 is a longitudinal sectional view of the same. Fig. 4 is a detail of the ventilating apparatus arranged in the floor of the room. Fig. 5 is a detail of the double fan, showing the method of arranging the same in the fan-casing.

In the drawings, 2 represents a suitable building of any size, construction, and arrangement, provided with suitable rooms 3 and with a suitable basement 5, in which is located the combined hot-air and steam heater. This heater is substantially in the form of a horizontal shell 7, preferably provided with the suitable flues 9, extending through it and communicating at the forward end with the smoke-drum 11, that communicates with the smoke-pipe 13. This shell is set in a suitable setting 15, preferably formed of brickwork or masonry and having beneath the forward end of the shell a bridge-wall 17 and grate-bars 19, beneath which is an ash-pit 21.

The forward end of the furnace is preferably provided with a suitable metallic front or casing 23, having the fuel-door 25 and ash-door 27. The ash-door may be provided with a damper 29, permitting the draft through this door to be regulated.

In the rear of the bridge-wall 17 is arranged the plate 25', which preferably extends up the rear side of the bridge-wall 17, as shown in Fig. 2, or begins at the tip of the wall, as shown in Fig. 3, then horizontally beneath the shell, then in a vertical direction to a point above the end of the flues 9, then in a horizontal direction forming a close joint with the end of the shell. This forms a flue beneath the shell for the products of combustion from the fire-box in the furnace to the flues 9, whereby said products of combustion are directed along beneath the shell, up at its rear end, and then through the flues 9 to the smoke-box 11 and smoke-stack 13.

Arranged in the rear of the bridge-wall 17 is a fan-casing 31. A shaft 33, mounted in suitable bearings, extends through this casing, and each end of the casing is open, and mounted upon the said shaft 33 in the opening in each end of the fan-casing is a fan 35, provided with a series of inclined blades. Said shaft is also provided with a suitable pulley 37, by means of which power may be applied thereto for the purpose of driving said shaft. When a strong draft is obtained through said fans 35, the currents of air, striking the inclined fan-blades, will cause the fans and the shaft to rotate. Arranged upon said shaft within said fan-casing 31 is a suitable fan 39. The rear of the fan-casing communicates, through a suitable opening 41, with the space beneath and back of the plate 25', said space thus forming an air-flue 43, that communicates with the interior of the shell through suitable openings 45 in the upper part of the rear end of said shell. The air entering the rear end of said shell preferably passes down under a deflecting-plate 47, as shown in Fig. 3, and becomes thoroughly heated in said shell, and then passes out through the dome 49 into suitable pipes 51, that lead to the various rooms that are to be heated. The space at the ends of the fan-casing 31 communicates with an opening 53, which extends through the bridge-wall 17 and communicates with the ash-pit 21 below the grate 19, as shown in Fig. 3. A suitable damper 55 is arranged to cover said opening, and it is provided with a handle 57 (see Fig. 2) extending outside of the furnace-wall and providing a means for opening or closing said

damper. When this damper is open, a part of the air will be forced from the fans 35 beneath the grate 19 and will then pass up through said grate, thus forming a forced draft for said furnace. Said furnace is also preferably provided with a self-feeding reservoir 61, arranged above said grate and adapted to receive a supply of coal through the opening 63, arranged in the front of the furnace. In some instances where a strong draft is attained it will be unnecessary to apply power to the shaft 33.

For the purpose of securing warm air to be drawn into said fan-casing I may arrange one or more conductors 65, having their upper open ends in the upper part of the basement, where the warm air that accumulates above said heater will be. The lower end of this conductor will communicate with one of the openings leading into the fan-casing, and warm air from the upper part of the basement will therefore be supplied to the fire. I also provide within the said shell, and preferably at the forward end thereof, directly over said fire-box, a small steam-boiler 67, which communicates with the steam-dome 69, that extends above the top of said shell. This dome may be provided with one or more pipes 71, to which suitable other steam-pipes may be connected for leading the steam to the steam coils or radiators suitably located in the rooms or apartments that are to be heated. A suitable tank 73, located outside the furnace, is connected by a pipe 75' with said boiler 67. This tank is closed and is arranged to be supplied with water from a reservoir 75, into which the water is forced by suitable means, which it is not necessary here to describe. A valve 77 is arranged to control the discharge of water from the reservoir 75 to the tank 73. A float 79, arranged within the tank 73, controls the valve 77. With this means the water in the boiler 67 is always kept at the same level, this being a low-pressure boiler and being automatically supplied from said tank 73. The condensed water from the steam pipes or radiators may be returned to the boiler or to the reservoir 75 by suitable means, which it is not necessary here to describe. The heated air from the heater is conducted to the rooms to be heated through suitable pipes 51, arranged in any preferred manner.

For the purpose of securing fresh air in the rooms I prefer to provide the open pipe 20, extending into the upper part of each room and provided with the valves or dampers 22, by means of which the amount of air entering each room may be regulated. I also prefer to provide in the floor of each room a cold-air distributor 24, consisting of a pipe extending through the floor of the room and provided with a valve 26, the lower end of said pipe communicating with a box 28, having inclined ends and provided with a series of holes in its ends and top. The air-currents passing downward through the pipe 24 and

entering the box 28 are distributed therein and pass out through said holes, and, striking the top or ceiling of the room, are deflected thereby and deflect through the room. I also prefer to provide means for drawing out the foul air from one of the rooms, consisting preferably of a pipe 30, arranged in the floor thereof and extending through the outer wall, with a steam-pipe 34 communicating with said pipe beneath a deflecting-plate 36. By this means a forced draft is created downward through the pipe 30 and the foul air from the bottom of the room is drawn downward through said pipe and forced outside of the building.

It will be understood that I do not confine myself to any particular arrangement of the steam or hot-air pipes in connection with said heater, as the same may be arranged in any convenient manner. When preferred, a pipe 18 may be arranged over the opening 14, extending substantially to the bottom of the heater, whereby the air drawn into the pipe will be taken from the bottom of the furnace-room or basement. This will remove the cold air from the bottom of the furnace-room, drawing it off into the chimney. The pipe 18, connected to the smoke-pipe 13, before referred to, may be connected with any room that it is desired to ventilate, whereby it will draw the cold air out of said room, and while I have designated the heater as placed in the basement it will be understood that it may be placed in any convenient part of the house or building to be heated, either on a level with or even above the rooms to be heated, where the fan is used for creating a forced current through the heater.

I am aware that ventilating-flues have been connected with apartments in buildings and extended through a hot-air chamber inside a furnace, and from thence into a smoke-flue, in such a manner that air would become heated in the tubes to facilitate the removal of foul air from the rooms.

I am also aware that there has been in use a device consisting of a chamber or tube suspended inside a smoke-pipe and so arranged with the flue of the chimney that the impure air which passes through said tube may be conducted off with the smoke. An opening in a chimney-flue which admits cold air will destroy the draft and cause the smoke at times to back up into the rooms unless some means are provided to force the air through the flue or to equalize the draft in the cold-air opening and the smoke-flue from the point where the cold air enters back to the fire. My combination ventilating device is so arranged in a smoke-pipe as to draw the smoke from the fire in the heating apparatus to the point where the cold air is admitted, thus equalizing the draft in the two pipes and carrying away the foul air, and my combination fan attachment is so arranged that by connecting the smoke-pipe to the inside fan-casing the blast may be turned into the smoke-flue to

improve the draft of the chimney, or it may be turned into the hot-air pipes to improve the circulation of air in the rooms, or into a pipe leading to the outside for ventilation only, and is of great use because by its use the heat or power of the draft of the chimney is utilized to draw the smoke over more radiating surface and to facilitate the removal of foul air from the rooms without injuring the draft of the furnace. By actual experiment it has been demonstrated that with the use of the double aprons arranged in my ventilating-trap all back-draft is prevented, and cold air admitted to the smoke-flue over said aprons does not check the draft of the furnace, but rather improves and strengthens it, and thus the constant stream of cold foul air carried off through the chimney does not affect the heating apparatus. It will be understood, moreover, that I do not confine myself to any particular arrangement of the details of the device herein described, as the same may be readily varied in many particulars without departing from my invention, and the ventilating-valves described may be placed in any convenient position.

I have shown and described the products of combustion as passing up the pipe 13 and meeting the cold air coming up through the opening 14. I may, however, reverse the operation, bringing the cold air through the pipe 13 over the valve 16 and passing the smoke up through the opening 14. I have also shown and described the opening 22' to be provided for the purpose of admitting cold air to the flue. I may, however, use this opening as an inlet for smoke, which arrangement will not interfere at all with the draft of the chimney, owing to the arrangement of the aprons 24 and 26.

Having thus described my invention, I claim as new and desire to secure by Letters Patent—

1. The combination, with the heater shell, provided with the horizontal smoke-flues 9, communicating with the smoke-box 11 and the smoke-pipe 13, and provided also with the hot air dome 49, the deflecting plate 47, and the opening 45, of the fire-box arranged beneath the forward end of said shell and provided with a grate 19 and the bridge wall 17,

the plate 25 forming a flue extending from said fire-box and communicating with said flues 9, the flue 43 extending beneath said plate 25 and connecting with said opening 45, the fan-casing 31 communicating with said flue 43, a fan arranged therein, and means for operating said fan, substantially as described.

2. The combination, with the heater, of the fan casing provided with an opening leading to the space beneath the fire pot, means for closing said opening, the shaft extending through said casing, the fan 39 upon said shaft, the outer fan casing and fans 35 also upon said shaft and arranged in the walls of said outer casing, substantially as described.

3. The combination, with the heater, of the inner fan casing having an opening 41 leading to the air flue 43, the shaft extending through said casing, the fan 39 upon said shaft, the outer fan casing and the fans 35 also upon said shaft and having inclined blades and arranged in the walls of said outer casing, substantially as described.

4. The combination, with the heater of the fan casing, provided with an opening leading to the space beneath the fire pot, a fan arranged to be driven by the current of air passing through said opening, a second fan to be driven by said first named fan, and arranged to force a current of air into the heating chamber substantially as described and for the purpose set forth.

5. The combination, with the heater, of the fan casing, provided with an opening leading to the space beneath the fire pot, a fan arranged to be driven by the suction of air through said opening, said fan having inclined blades, a second fan to be driven by said first named fan, and said casing being provided with an exit opening to permit the current of air to pass into the heating chamber, substantially as described and for the purpose set forth.

In testimony whereof I have hereunto set my hand this 26th day of May, A. D. 1894.

DAVID S. WHITE.

In presence of—

A. C. PAUL,
FREDERICK S. LYON.