

No. 820,115.

PATENTED MAY 8, 1906.

H. T. HORNSBY & T. R. WESTON.

BRAKE SHOE.

APPLICATION FILED DEC. 22, 1905.

Fig. 1.

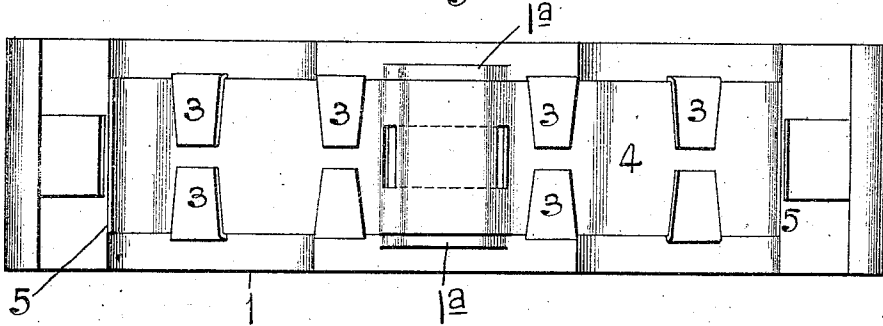

Fig. 2.

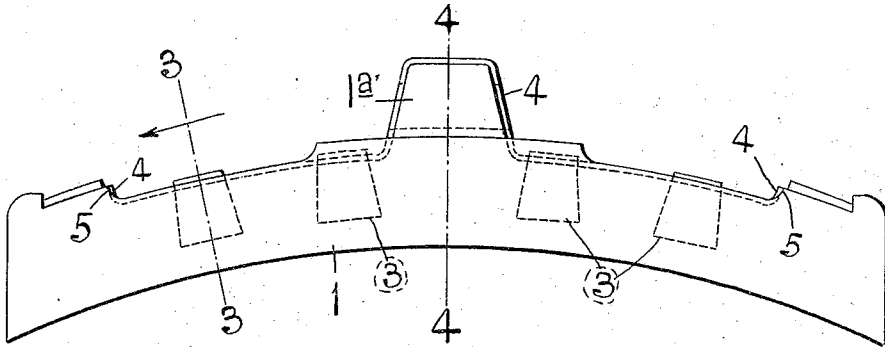

Fig. 3.

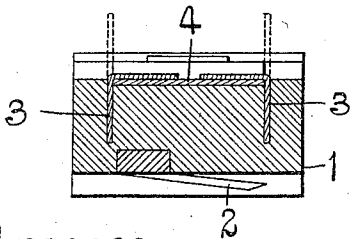
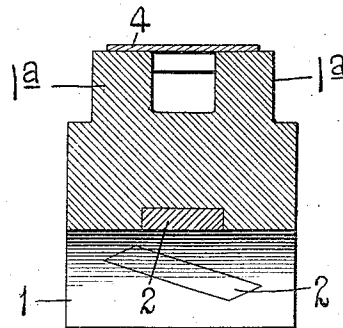

Fig. 4.



Witnesses

A. J. McCauley

Wm. J. Farmer

Inventor's:

Henry T. Hornsby

Thomas R. Weston

by Bekewell Cornwallis Abby's

UNITED STATES PATENT OFFICE.

HENRY T. HORNSBY AND THOMAS R. WESTON, OF SPRINGFIELD,
MISSOURI, ASSIGNORS TO UNITED IRON WORKS COMPANY, OF
SPRINGFIELD, MISSOURI, A CORPORATION OF MISSOURI.

BRAKE-SHOE.

No. 820,115.

Specification of Letters Patent.

Patented May 8, 1906.

Application filed December 22, 1905. Serial No. 293,009.

To all whom it may concern:

Be it known that we, HENRY T. HORNSBY and THOMAS R. WESTON, citizens of the United States, residing at Springfield, Greene county, Missouri, have jointly invented a certain new and useful Improvement in Brake-Shoes, of which the following is a full, clear, and exact description, such as will enable others skilled in the art to which it appertains to make and use the same, reference being had to the accompanying drawings, forming part of this specification, in which—

Figure 1 is a back view of our improved brake-shoe. Fig. 2 is a side elevational view. Fig. 3 is a cross-sectional view on the line 3 3 of Fig. 2, and Fig. 4 is a cross-sectional view on the line 4 4 of Fig. 2.

This invention relates to a new and useful improvement in brake-shoes, the object being to provide the brake-shoe with a removable back capable of continued use in connection with different shoes.

Heretofore it has been the practice in manufacturing brake-shoes to cast the key-lug and body portion of the shoe so that there existed a permanent (or integral, as the case may be) connection between the two, and when the shoe became worn and had to be replaced the old shoe had to be thrown away, entailing a loss by waste of the parts which were in sufficiently good shape to be used over again. In the practice of our invention we provide a removable backing for the shoe, securing said backing in position by fastening devices preferably permanently connected to the shoe, whereby a temporary connection is established between the backing and the shoe, so that when the shoe is worn if the backing is in good shape these temporary fastenings may be manipulated so as to enable the backing to be removed from the old shoe and used in connection with a new shoe.

With these objects in view the invention consists in the construction, arrangement, and combination of the several parts, all as will be hereinafter described, and afterward pointed out in the claims.

In the drawings, 1 indicates the body of the brake-shoe, preferably made of cast iron or steel, and in the face of which may be em-

bedded the usual inserts 2. Where the body of the brake-shoe is made of cast-iron, these inserts may be of a soft metal, such as wrought-iron, or in the event the body of the shoe is made of steel or other soft metal the inserts 2 may be made of chilled iron or other hard material. So far as the body of the shoe, the inserts, and the material of which they are composed are concerned they may be of the usual or any approved design or character.

3 represents tongues of sheet metal, preferably wedge-shaped, with the enlarged ends embedded in the material constituting the body of the shoes. These tongues are preferably placed in position in the mold before the body of the shoe is cast, so that the cast metal flows around the tongues and the tongues are permanently connected to the body of the shoe. There may be any desired number of these tongues and they may be arranged in any convenient position on the shoe.

4 is the backing of the shoe, which is preferably made of sheet metal pressed or stamped into shape, so as to conform to the back of the shoe. This backing 4 in being mounted on a shoe is arranged between the tongues 3, and said tongues are bent over the backing to hold it in place, as shown. The body portion of the shoe at the ends of the backing is preferably provided with shoulders 5 to assist in holding the backing in position, and in addition the body portion is preferably provided with lugs 1^a, extending up on each side of the key-opening and into the central raised portion of the backing. By this method of mounting the backing it is prevented from independent movement in any direction with relation to the body of the shoe. Should the shoe become worn, it is only necessary to bend back the tongues 3, when the backing can be removed and used on a new shoe.

We are aware that minor changes in the construction, arrangement, and combination of the several parts of our device can be made and substituted for those herein shown and described without in the least departing from the nature and principle of our invention.

Having thus described the invention, what

is claimed as new, and desired to be secured by Letters Patent, is—

1. A brake-shoe having a removable backing formed of sheet metal and following the shape of the shoe, in combination with fastening devices embedded in the back of the body portion of the shoe and adapted to be bent to engage a portion of the backing to hold it in position; substantially as described.
2. In a brake-shoe, the combination with a body portion having flexible fastening-tongues embedded in the back thereof, and a removable sheet-metal backing having a raised portion for engagement with a brake-key and adapted to be held in position by the flexible tongues which are bent to engage the same; substantially as described.
3. In a brake-shoe, the combination with a body portion, of fastening devices permanently connected therewith, a sheet-metal backing having a raised portion for coöperation with the brake-key, and legs or extensions formed integral with the back of the

body portion and extending into the raised portion of the sheet-metal back; substantially as described.

4. The herein-described brake-shoe, the same having flexible-tongues embedded into the body portion thereof, shoulders on the back of the body portion adjacent its ends, and a removable backing engaging said shoulders and held in position by said flexible tongues; substantially as described.

5. The herein-described brake-shoe, the same having wedge-shaped flexible tongues arranged in the back thereof, the larger parts of said tongues being embedded in the body of the shoe; substantially as described.

In testimony whereof we hereunto affix our signatures, in the presence of two witnesses, this 16th day of December, 1905.

HENRY T. HORNSBY.
THOMAS R. WESTON.

Witnesses:

A. C. DAILY,
T. R. STOKES.