

J. NAPIER.

Improvement in Plow-Clevis.

No. 130,145.

Patented Aug. 6, 1872.

Fig. 1.

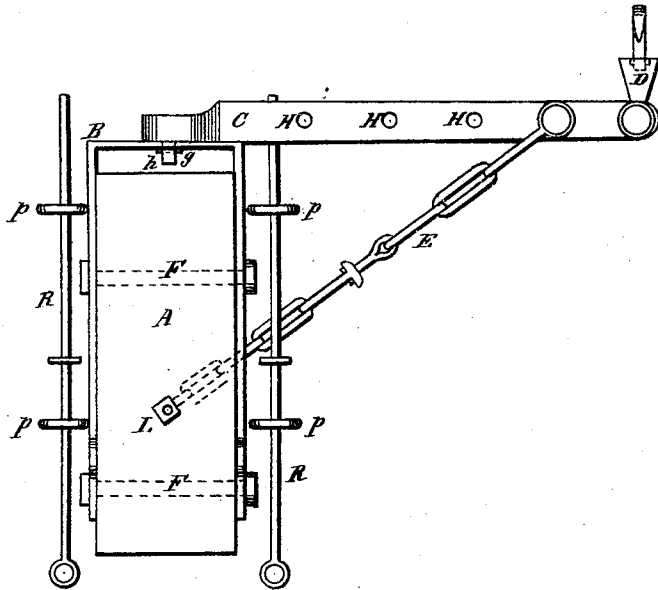
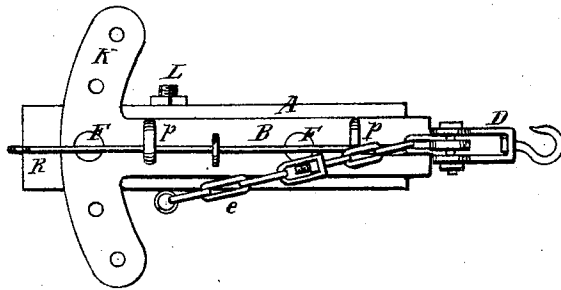

Fig. 2.



Witnesses:

*James Eagles on*  
*Robert Hanson*

Inventor:

*James Napier*

# UNITED STATES PATENT OFFICE.

JAMES NAPIER, OF MARTIN'S FERRY, OHIO.

## IMPROVEMENT IN PLOW-CLEVISES.

Specification forming part of Letters Patent No. 130,145, dated August 6, 1872.

I, JAMES NAPIER, of Martin's Ferry, in the county of Belmont and State of Ohio, have invented certain Improvements in Plow-Clevises, of which the following is a specification:

The nature of my invention consists in the construction of an iron lever, fitting at one end by a round shoulder into a clevis fastened to the end of the beam of the plow in such a manner as to extend at right angles to one side of the beam and at the same time to revolve freely. The lever is attached to the beam itself by an iron chain, which fastens to it by a common clevis, and is supported in its place by rods passing through eyebolts on either side of the beam, and extending forward under the lever, and back to the handles of the plow, so as to be used at pleasure. At the other end of the lever is attached a rivet-clevis to connect it to the single-tree, and which prevents them from being twisted when the lever revolves. The object of my invention is to place the horse, when plowing, at a distance from the crop to be plowed, and thus prevent it from being injured by the striking of the single-tree or the horse, and that the horse can be changed to either side of the beam of the plow, as required when plowing.

### *Description of the Accompanying Drawing.*

Figure 1 is a top view of the plow-clevis embodying my invention. Fig. 2 is a side view of the same.

### *General Description.*

A is the beam of the plow. B is an iron clevis, fitting on the side of the beam of the plow, fastened by the bolts F, and extending past the end of the beam so as to allow room for the shoulder *n* to revolve freely. At the back end of the clevis B are iron ears K, in Fig. 2, and form part of the clevis, into which the hindermost bolt F fits, and is used for the purpose of regulating the depth of the furrow by moving upward or downward, as may be

required. C is a flat iron lever or shaft, and is attached at one end to the clevis B by a round shoulder, *n*, and fastened on the inner side of the clevis B by an iron pin, *g*. This shoulder is made so as to revolve freely. At the other end of C is attached an iron clevis, D, into the end of which fits an iron hook so as to revolve and keep the single-tree from twisting or being inverted when the lever C is thrown to the other side of the beam of the plow. When the plow is taking too much land, then the clevis D is moved nearer the beam, in the holes H H H. If taking too little land, then the clevis D is moved to the outer holes. E is an iron chain for the purpose of draft, and is fastened on the under side of the beam A by a ring in the head of the bolt L, in Fig. 2, and is attached to the lever C by a common clevis. In the middle of the chain E is a swivel to keep the chain from being twisted. R R are two iron rods passing through eyelets P P, screwed into clevis B, and pass backward to the handle of the plow and forward under the clevis C, and are used to support it.

When it is required to change the lever C to the other side of the beam of the plow the rod is pulled back, when C drops down, the draft of the horse raises it to its place on the other side; then the rod R is pushed forward.

### *Claim.*

I claim as my invention—

The revolving lever C with the iron pin *g*, the iron chain E connecting it with beam of plow, the swivel-clevis D for attaching the single-trees, and the iron rods R R for its support, as and for the purposes hereinbefore set forth.

JAMES NAPIER.

Witnesses:

GEORGE JAMES,  
JAMES EAGLESON.