

(19) World Intellectual Property Organization
International Bureau



(43) International Publication Date
14 July 2011 (14.07.2011)

(10) International Publication Number
WO 2011/085212 A2

(51) International Patent Classification:
A61B 17/70 (2006.01)

(21) International Application Number:
PCT/US2011/020535

(22) International Filing Date:
7 January 2011 (07.01.2011)

(25) Filing Language: English

(26) Publication Language: English

(30) Priority Data:
12/683,555 7 January 2010 (07.01.2010) US
12/868,818 26 August 2010 (26.08.2010) US

(71) Applicant (for all designated States except US): **RE-LIEVANT MEDSYSTEMS, INC.** [US/US]; 2688 Middlefield Road, Suite A, Redwood City, California 94063 (US).

(72) Inventors; and

(75) Inventors/Applicants (for US only): **PELLEGRINO, Richard** [US/US]; 738 El Granada Boulevard, Half

Moon Bay, California 94019 (US). **PATEL, Samit** [US/US]; 1730 Jackson Street, San Francisco, California 94109 (US). **CARRISON, Harold** [US/US]; 410 Dolores Court, Pleasanton, California 94566 (US).

(74) Agent: **O'BANION, John**; O'Banion & Ritchey LLP, 400 Capitol Mall, Suite 1550, Sacramento, CA 95814 (US).

(81) Designated States (unless otherwise indicated, for every kind of national protection available): AE, AG, AL, AM, AO, AT, AU, AZ, BA, BB, BG, BH, BR, BW, BY, BZ, CA, CH, CL, CN, CO, CR, CU, CZ, DE, DK, DM, DO, DZ, EC, EE, EG, ES, FI, GB, GD, GE, GH, GM, GT, HN, HR, HU, ID, IL, IN, IS, JP, KE, KG, KM, KN, KP, KR, KZ, LA, LC, LK, LR, LS, LT, LU, LY, MA, MD, ME, MG, MK, MN, MW, MX, MY, MZ, NA, NG, NI, NO, NZ, OM, PE, PG, PH, PL, PT, RO, RS, RU, SC, SD, SE, SG, SK, SL, SM, ST, SV, SY, TH, TJ, TM, TN, TR, TT, TZ, UA, UG, US, UZ, VC, VN, ZA, ZM, ZW.

(84) Designated States (unless otherwise indicated, for every kind of regional protection available): ARIPO (BW, GH,

[Continued on next page]

(54) Title: SYSTEMS AND METHODS FOR NAVIGATING AN INSTRUMENT THROUGH BONE

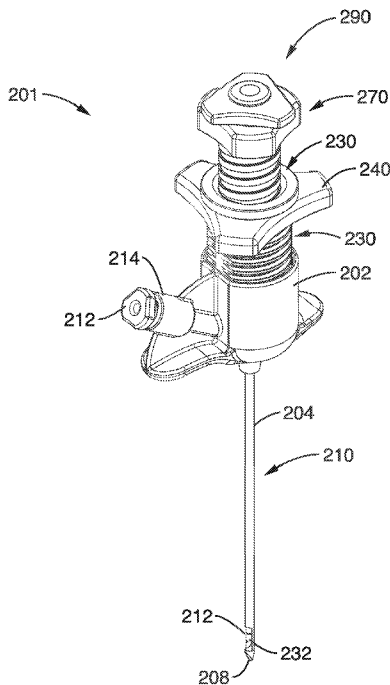
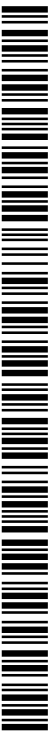

FIG. 8

(57) Abstract: System and methods for channeling a path into bone include a trocar having a proximal end, distal end and a central channel disposed along a central axis of the trocar. The trocar includes a radial opening at or near the distal end of the trocar. The system includes a curveable cannula sized to be received in the central channel, the curveable cannula comprising a curveable distal end configured to be extended laterally outward from the radial opening in a curved path extending away from the trocar. The curveable cannula has a central passageway having a diameter configured allow a probe to be delivered through the central passageway to a location beyond the curved path.



WO 2011/085212 A2

GM, KE, LR, LS, MW, MZ, NA, SD, SL, SZ, TZ, UG, ZM, ZW), Eurasian (AM, AZ, BY, KG, KZ, MD, RU, TJ, TM), European (AL, AT, BE, BG, CH, CY, CZ, DE, DK, EE, ES, FI, FR, GB, GR, HR, HU, IE, IS, IT, LT, LU, LV, MC, MK, MT, NL, NO, PL, PT, RO, RS, SE, SI, SK, SM, TR), OAPI (BF, BJ, CF, CG, CI, CM, GA, GN, GQ, GW, ML, MR, NE, SN, TD, TG).

Published:

— *without international search report and to be republished upon receipt of that report (Rule 48.2(g))*

**SYSTEMS AND METHODS FOR NAVIGATING AN
INSTRUMENT THROUGH BONE**

CROSS-REFERENCE TO RELATED APPLICATIONS

5 **[0001]** This application is claims priority from U.S. application serial number 12/868,818 filed on August 26, 2010, which is a continuation of U.S. application serial number 12/683,555 filed on January 7, 2010, incorporated herein by reference in its entirety.

10 **STATEMENT REGARDING FEDERALLY SPONSORED RESEARCH
OR DEVELOPMENT**

[0002] Not Applicable

**INCORPORATION-BY-REFERENCE OF MATERIAL
SUBMITTED ON A COMPACT DISC**

15 **[0003]** Not Applicable

NOTICE OF MATERIAL SUBJECT TO COPYRIGHT PROTECTION

20 **[0004]** A portion of the material in this patent document is subject to copyright protection under the copyright laws of the United States and of other countries. The owner of the copyright rights has no objection to the facsimile reproduction by anyone of the patent document or the patent disclosure, as it appears in the United States Patent and Trademark Office publicly available file or records, but otherwise reserves all copyright rights whatsoever. The copyright owner does not hereby waive any of its rights to have this patent document maintained in secrecy, including without limitation its rights pursuant
25 to 37 C.F.R. § 1.14.

BACKGROUND OF THE INVENTION

30 **[0005]** 1. Field of the Invention
[0006] This invention pertains generally to generating passageways through

tissue, and more particularly to creating curved paths in bone.

[0007] 2. Description of Related Art

[0008] Recently, the technique of accessing the vertebral body through minimally invasive means has been developed through the surgical techniques used in vertebroplasty and kyphoplasty. Although accessing the vertebral segments of the spine through the pedicle and into the lateral / anterior section of the body of the vertebra is the primary method of placing a treatment device (e.g. a bone cement delivery device and/or an RF probe) into the vertebra, it is difficult to place a probe in the posterior midline section of the vertebra.

5

10

Furthermore, accessing the posterior midline section of the S1 segment of the spine is difficult with a straight linear access route. A probe preferably needs to be capable of navigating to the posterior section of the S1 vertebral body as well as the same target area within a lumbar vertebral segment. In addition, it is contemplated that spinal segments in the cervical and thoracic spine may also be targeted.

15

[0009] In order to accurately and predictably place a treatment device in the posterior midline section of a lumbar vertebral body or S1 vertebral body, the device or probe needs to navigate to said area through varying densities of bone. However due to the varying densities of bone, it is difficult to navigate a probe in bone and ensure its positioning will be in the posterior midline section of the vertebral body.

20

[0010] Current techniques for tissue aspirations require a coaxial needle system that allows taking several aspirates through a guide needle without repositioning the guide needle. However the problem with this system is that after the first pass of the inner needle in to the lesion, subsequent passes tend of follow the same path within the mass, yielding only blood not diagnostic cells.

25

[0011] A scientific paper written by Kopecky et al., entitled "Side-Exiting Coaxial Needle for Aspiration Biopsy," describes the use of a side exiting coaxial needle to allow for several aspiration biopsies. The guide needle has a side hole 1cm from the distal tip. When a smaller needle is advanced

30

through this new guide needle, the smaller needle is deflected by a ramp inside the guide, causing the smaller needle to exit through the side hole. Although this side exiting needle is able to deflect a bone aspiration needle, it does not guarantee that the needle exits the side hole in a linear direction into the tissue site. Once the tissue aspiration needle exits the needle, it will deviate from a linear path depending on the density of the tissue and inherent material strength of the needle. This is an inherent problem the device is unable to overcome.

[0012] Accordingly, an object of the present invention is a system and method for generating a path in bone that predictably follows a predetermined curved path.

BRIEF SUMMARY OF THE INVENTION

[0013] The present invention is directed to systems and methods to deploy and navigate a flexible treatment instrument, such as an RF bipolar probe, within bone. Although the systems and methods described below are primarily directed to navigating bone through a vertebral member of the spine, and particularly to treat the BVN of a vertebral member, it is appreciated that the novel aspects of the present invention may be applied to any tissue segment of the body.

[0014] The first novel principle of this invention is the ability to navigate a curve or angle within varying densities of cancellous bone and create a straight channel at the end of the navigated curve or angle. Several systems are described.

[0015] One aspect is a method of therapeutically treating a vertebral body having an outer cortical bone region and an inner cancellous bone region, and a BVN having a trunk extending from the outer cortical bone region into the inner cancellous region and a branches extending from the trunk to define a BVN junction, comprising the steps of: a) inserting an energy device into the vertebral body, and b) exclusively depositing energy within the inner cancellous bone region of the vertebral body between, but exclusive of the BVN junction and the outer cortical bone region, to denervate the BVN.

[0016] In another aspect of the present invention, a tube-within-tube embodiment has a deployable curved Nitinol tube that deploys from a straight cannula. The Nitinol tube is pre-curved to create an angular range of approximately 0° to approximately 180°, but more specifically from approximately 45° to approximately 110°, when fully deployed from the straight cannula. The design of the curve is such that the flexible element (carrying the treatment device) can navigate through the angular range of deployment of the nitinol tube. The curved nitinol tube allows the flexible element to navigate through a curve within bone without veering off towards an unintended direction. Cancellous bone density varies from person to person. Therefore, creating a curved channel within varying density cancellous bone will generally not predictably or accurately support and contain the treatment device as it tries to navigate the curved channel. With the present invention, the flexible element is deployed into the bone through the curved Nitinol tube, which supports the element as it traverses through the curve. When it departs from the tube, it will do so in a linear direction towards the target zone. This design allows the user to predictably and accurately deploy the flexible element towards the target zone regardless of the density of the cancellous bone.

[0017] An aspect of the invention is a system for channeling a path into bone. The system comprises a trocar having a central channel and opening at its distal tip, and a cannula sized to be received in said central channel and delivered to the distal opening. The cannula has a deflectable tip with a preformed curve such that the tip straightens while being delivered through the trocar and regains its preformed curve upon exiting and extending past the distal opening of the trocar to generate a curved path in the bone corresponding to the preformed curve of the deflectable tip. The cannula comprises a central passageway having a diameter configured allow a treatment device to be delivered through the central passageway to a location beyond the curved path.

[0018] In one embodiment, the system further includes a straight stylet

configured to be installed in the trocar, wherein the straight stylet comprises a sharp distal tip that is configured to extend beyond the distal opening of the trocar to pierce the bone as the trocar is being delivered to a treatment location within the bone.

5 **[0019]** The system may further include a straightening stylet configured to be installed in the cannula, wherein the straightening stylet comprising a rigid construction configured to straighten the distal tip of the cannula when positioned in the trocar.

10 **[0020]** In an alternative embodiment, the straightening stylet further comprises a sharp distal end to pierce the bone, and the straightening stylet and cannula are installed in the trocar in place of the straight stylet as the trocar is delivered into the bone.

15 **[0021]** In a preferred embodiment, the system further includes a curved stylet having an outer radius sized to fit within the central passageway of the curved cannula. The curved stylet is configured to be installed in the curved cannula while the curved cannula is extended past the distal opening of the trocar, the curved stylet configured to block the distal opening of the curved cannula while being delivered into the bone. Preferably, the curved stylet has a curved distal end corresponding to the curve of the curved cannula.

20 **[0022]** The curved stylet also has a sharp distal tip configured to extend past the curved cannula to pierce the bone as the cannula is delivered past the distal opening of the trocar. The curved stylet also preferably comprises an angled distal tip configured to further support and maintain the curved stylet radius as it is delivered past the distal opening of the trocar and into bone.

25 **[0023]** Preferably, the curved stylet and the curved cannula have mating proximal ends that align the curve of the curved stylet with the curve of the curved cannula.

30 **[0024]** In one embodiment, the system further includes a straight channeling stylet configured to be installed in the cannula after removing the curved stylet, wherein the straight channeling stylet is flexibly deformable to navigate the curved cannula yet retain a straight form upon exiting the curve cannula, and

wherein straight channeling stylet has a length longer than the curved cannula such that it creates a linear path beyond the distal end of the curved cannula when fully extended.

5 [0025] Another aspect is method for channeling a path into bone to a treatment location in the body of a patient. The method includes the steps of inserting a trocar having a central channel and opening at its distal tip into a region of bone at or near the treatment location, and delivering a cannula through said central channel and to said distal opening, wherein the cannula comprises a deflectable tip with a preformed curve such that the tip
10 straightens while being delivered through the trocar and regains its preformed curve upon exiting the trocar, and extending the cannula past the distal opening of the trocar to generate a curved path in the bone corresponding to the preformed curve of the deflectable tip. Finally, a treatment device is delivered through a central passageway in said cannula having to the
15 treatment location beyond the curved path.

[0026] In one embodiment, inserting a trocar into a region of bone comprises inserting a stylet into the trocar such that the stylet extends beyond the distal opening of the trocar, and inserting the stylet and trocar simultaneously into the region of bone such that the stylet pierces the bone as the trocar is being
20 delivered to a treatment location.

[0027] In another embodiment, delivering a cannula through the central channel comprises inserting a straightening stylet into the central passageway of the cannula, wherein the straightening stylet comprises a rigid construction configured to straighten the curved distal tip of the cannula, and inserting the
25 straightening stylet and straightened cannula simultaneously into the trocar.

[0028] In an alternative embodiment, the straightening stylet further comprises a sharp distal end to pierce the bone, wherein the straightening stylet and cannula are installed simultaneously along with the trocar as the trocar is delivered into the bone.

30 [0029] In yet another embodiment, extending the cannula past the distal opening is done by inserting a curved stylet into the central passageway of the

curved cannula such that a distal tip of the curved stylet extends to at least the distal opening of the curved cannula, and simultaneously extending the curved cannula and curved stylet from the distal end of the trocar such that the curved stylet blocks the distal opening of the curved cannula while being delivered
5 into the bone.

[0030] In a preferred embodiment, the curved stylet has a curved distal end corresponding to the curve of the curved cannula, and wherein the curved stylet reinforces the curved shape of the curved cannula as the curved cannula is extended past the distal opening of the trocar. The curved stylet
10 has a sharp distal tip such that it is advanced within the central passageway so that the curved stylet extends past the distal opening of the curved cannula such that the curved stylet pierces the bone as the cannula is delivered past the distal opening of the trocar.

[0031] In a further step, the curved stylet is removed from the curved cannula,
15 and a straight channeling stylet is inserted into the curved distal end of the cannula. The straight channeling stylet is flexibly deformable to navigate the curved cannula, yet retain a straight form upon exiting the curved cannula. The straight channeling stylet is longer than the curved cannula to create a linear channel beyond the distal tip of the curved cannula.

[0032] In a preferred embodiment, the trocar is inserted through a cortical
20 bone region and into a cancellous bone region of a vertebrae, and the curved cannula is extended though at least a portion of the cancellous bone region to a location at or near the treatment location. A preferred treatment location comprises a BVN of the vertebrae, and treatment is delivered to the treatment
25 location to denervate at least a portion of the BVN. In one embodiment, a portion of the BVN is denervated by delivering focused, therapeutic heating to an isolated region of the BVN. In another embodiment, a portion of the BVN comprises is denervated delivering an agent to the treatment region to isolate
30 treatment to that region. Preferably, the treatment is focused on a location of the BVN that is downstream of one or more branches of the BVN.

[0033] Another aspect is a kit for channeling a path into bone. The kit includes

a trocar having a central channel and opening at its distal tip, and a cannula selected from a set of cannulas sized to be received in said central channel and delivered to said distal opening. The cannula has a deflectable distal tip with a preformed curve such that the tip straightens while being delivered
5 through the trocar and regains its preformed curve upon exiting and extending past the distal opening of the trocar to generate a curved path in the bone corresponding to the preformed curve of the deflectable tip. The cannula comprises a central passageway having a diameter configured allow a treatment device to be delivered through the central passageway to a location
10 beyond the curved path, wherein the set of cannulas comprises one or more cannulas that have varying preformed curvatures at the distal tip.

[0034] In a preferred embodiment, the one or more cannulas have a varying preformed radius at the distal tip. In addition, the one or more cannulas each have distal tips that terminate at varying angles with respect to the central
15 channel of the trocar. The length of the distal tips may also be varied. The angle of the distal with respect to the central channel of the trocar may vary from 0 degrees to 180 degrees.

[0035] The kit may further include a straight stylet configured to be installed in the trocar, the straight stylet comprising a sharp distal tip that is configured to
20 extend beyond the distal opening of the trocar to pierce the bone as the trocar is being delivered to a treatment location within the bone.

[0036] In a preferred embodiment, the kit includes a set of curved stylets having an outer radius sized to fit within the central passageway of the curved cannula, wherein each curved stylet is configured to be installed in the curved
25 cannula while the curved cannula is extended past the distal opening of the trocar. The curved stylet is configured to block the distal opening of the curved cannula while being delivered into the bone. Each curved stylet has a varying curved distal end corresponding to the curve of a matching curved cannula in the set of curved cannulas. The curved stylet has a sharp distal tip configured
30 to extend past the curved cannula to pierce the bone as the cannula is delivered past the distal opening of the trocar.

[0037] In another embodiment, the kit includes a set of straight channeling stylets wherein one of the set of stylets is configured to be installed in the cannula after removing the curved stylet. The straight channeling stylet is flexibly deformable to navigate the curved cannula yet retain a straight form upon exiting the curve cannula. Each of the straight channeling stylets has a varying length longer than the curved cannula such that the straight channeling stylet creates a predetermined-length linear path beyond the distal end of the curved cannula when fully extended.

[0038] Another aspect is a system for channeling a path into bone, having a trocar with a proximal end, distal end and a central channel disposed along a central axis of the trocar and extending from the proximal end toward the distal end. The trocar comprises a radial opening at or near the distal end of the trocar, the radial opening being in communication with the central channel. The system includes a curveable cannula sized to be received in said central channel and delivered from the proximal end toward said radial opening. The curveable cannula comprises a curveable distal end configured to be extended laterally outward from the radial opening in a curved path extending away from the trocar, and a central passageway having a diameter configured allow a probe to be delivered through the central passageway to a location beyond the curved path.

[0039] A further aspect is a spine therapy system, comprising: a trocar having a proximal end, distal end and a central channel; wherein the central channel is disposed along a central axis of the trocar and extends from the proximal end toward the distal end; wherein the trocar comprises a radial opening at or near the distal end of the trocar, the radial opening being in communication with the central channel; wherein the trocar is configured to be deployed through a cortical bone region and into a cancellous bone region of a vertebral body; a curveable cannula sized to be received in said central channel and delivered from the proximal end toward said radial opening; the curveable cannula comprising a central passageway and curveable distal end configured to be extended laterally outward from the radial opening in a curved path

extending away from the trocar; wherein the curved path is generated though at least a portion of the cancellous bone region of the vertebral body; and a treatment probe configured to be delivered through the central passageway to a location beyond the curved path.

- 5 **[0040]** Another aspect is a method for channeling a path into bone to a treatment location in the body of a patient, comprising the steps of inserting a trocar into a region of bone near the treatment location; the trocar having a proximal end, distal end and a central channel disposed therebetween; wherein the trocar comprises a radial opening at or near the distal end of the trocar, the radial opening being in communication with the central channel; delivering a curveable cannula through said central channel and to said radial opening; and deploying the curveable cannula laterally outward from the radial opening in a curved path extending away from the trocar
- 10
- 15 **[0041]** Further aspects of the invention will be brought out in the following portions of the specification, wherein the detailed description is for the purpose of fully disclosing preferred embodiments of the invention without placing limitations thereon.

BRIEF DESCRIPTION OF THE SEVERAL VIEWS
OF THE DRAWING(S)

- 20 **[0042]** The invention will be more fully understood by reference to the following drawings which are for illustrative purposes only:
- [0043]** FIG. 1 is a system for generating a curved path in bone according to the present invention.
- 25 **[0044]** FIG. 2 is a sectional view of the system of FIG. 1
- [0045]** FIG. 3 illustrates a sectioned view of a vertebral body with a path bored through the cortical shell.
- [0046]** FIGS. 4A-F illustrate a method for accessing the BVN with the system of the present invention.
- 30 **[0047]** FIG. 5 shows an alternative system for generating a curved path in bone according to the present invention.

[0048] FIG. 6 shows the system of FIG. 5 being installed in a vertebral body.

[0049] FIGS. 7A-7B show a curved stylet in accordance with the present invention.

[0050] FIG. 8 illustrates a perspective view of a system for generating a curved path in bone according to the present invention.

[0051] FIG. 9 is an exploded view of the system of FIG. 8.

[0052] FIG. 10A-10E show schematic diagrams of the system of FIG. 8 at various stages of deployment during a procedure.

[0053] FIG. 11 is a section view of the proximal end of the system of FIG. 8 during introduction of the system into the body.

[0054] FIG. 12 is a side view of the distal end of the system of FIG. 8 during introduction of the system into the body.

[0055] FIG. 13 is a section view of the proximal end of the system of FIG. 8 after deploying the curveable cannula into the body.

[0056] FIG. 14 is a side view of the distal end of the system of FIG. 8 after deploying the curveable cannula into the body.

[0057] FIG. 15 is a section view of the proximal end of the system of FIG. 8 with the drive nut retracted.

[0058] FIG. 16 is a section view of the proximal end of the system of FIG. 8 after deploying the probe into the body.

[0059] FIG. 17 is a side view of the distal end of the system of FIG. 8 after deploying the probe into the body.

[0060] FIGS. 18A and 18B are side views of the distal end of the system of FIG. 8 with the curveable cannula in a stowed and deployed position respectively.

[0061] FIG. 19A illustrates a perspective view of an alternative system for generating a curved path in bone according to the present invention.

[0062] FIG. 19B illustrates the system of FIG. 19A in a deployed configuration.

DETAILED DESCRIPTION OF THE INVENTION

[0063] Referring more specifically to the drawings, for illustrative purposes the present invention is embodied in the apparatus generally shown in FIG. 1

through FIG. 19B. It will be appreciated that the apparatus may vary as to configuration and as to details of the parts, and that the method may vary as to the specific steps and sequence, without departing from the basic concepts as disclosed herein.

5 **[0064]** Tube-In-Tube

[0065] FIGS. 1 and 2 illustrate a first embodiment of the present invention comprising a system or kit 10 for forming a path through bone. The system comprises a having a needle trocar 20 (the main body of the instrument set). The trocar 20 comprises an elongate shaft 28 having a handle 24 at its proximal end 32 and a central lumen 36 passing through to the distal end 22 of the trocar 20. The central lumen 36 is generally sized to allow the other instruments in the system 10 to be slideably introduced into the patient to a treatment region. System 10 further comprises a straight stylet 80 having a sharp-tipped needle 84 at its distal end that is used with the needle trocar 20 to create the initial path through the soft tissue and cortical shell to allow access to the cancellous bone, a curved cannula 50 that is used to create/maintain the curved path within the bone/tissue. A straightening stylet 40 is used to straighten out the curve and load the curved cannula 50 into the needle trocar 20. A curved stylet 60 is used in conjunction with the curved cannula 50 to create the curved path within the bone/tissue, and a channeling stylet 90 is used to create a working channel for a treatment device (such as RF probe 100) beyond the end of the curved path created by the curved cannula 50.

[0066] The surgical devices and surgical systems described may be used to deliver numerous types of treatment devices to varying regions of the body. Although the devices and systems of the present invention are particularly useful in navigating through bone, it is appreciated that they may also be used to navigate through soft tissue, or through channels or lumens in the body, particularly where one lumen may branch from another lumen.

30 **[0067]** The following examples illustrate the system 10 applied to generating a curve bone path in the vertebral body, and more particularly for creating a

bone path via a transpedicular approach to access targeted regions in the spine. In particular, the system 10 may be used to deliver a treatment device to treat or ablate intraosseous nerves, and in particular that basivertebral nerve (BVN). Although the system and methods provide significant benefit in accessing the BVN, it is appreciated that the system 10 of the present invention may similarly be used to create a bone path in any part of the body.

5
[0068] FIG. 3 illustrates a cross-sectional view of a vertebra 120. Recently, the existence of substantial intraosseous nerves 122 and nerve branches 130 within human vertebral bodies ("basivertebral nerves") has been identified. The nerve basivertebral 122 has at least one exit 142 point at a location along the nerve 122 where the nerve 122 exits the vertebral body 126 into the vertebral foramen 132.

10
[0069] Preferably, the basivertebral nerves are at, or in close proximity to, the exit point 142. Thus, the target region of the BVN 122 is located within the cancellous portion 124 of the bone (i.e., to the interior of the outer cortical bone region 128), and proximal to the junction J of the BVN 122 having a plurality of branches 130 (e.g. between points A and B along nerve 122). Treatment in this region is advantageous because only a single portion of the BVN 122 need be effectively treated to denervate or affect the entire system. Typically, treatment in accordance with this embodiment can be effectuated by focusing in the region of the vertebral body located between 60% (point A) and 90% (point B) of the distance between the anterior and posterior ends of the vertebral body. In contrast, treatment of the BVN 122 in locations more downstream than the junction J requires the denervation of each branch 130.

15
20
25 [0070] In one approach for accessing the BVN, the patient's skin is penetrated with a surgical instrument which is then used to access the desired basivertebral nerves, i.e., percutaneously. In one embodiment, a transpedicular approach is used for penetrating the vertebral cortex to access the BVN 122. A passageway 140 is created between the transverse process 134 and spinous process 136 through the pedicle 138 into the cancellous bone region 124 of the vertebral body 126 to access a region at or near the base of

the nerve 122. It is appreciated that a postereolateral approach (not shown) may also be used for accessing the nerve.

[0071] FIGS. 4A-F illustrate a preferred method for accessing the BVN with the system 10 of the present invention. First, the straight stylet 80 is inserted in aperture 26 at the proximal end 32 of needle trocar 20. The straight stylet 80 is advanced down the central lumen 36 (see FIG. 2) of the trocar 20 until the proximal stop 82 abuts against handle 24 of the trocar 20, at which point the distal tip 84 of straight stylet protrudes out of the distal end 22 of the trocar 20. The tip 84 of the straight stylet 80 preferably comprises a sharp tip for piercing soft tissue and bone.

[0072] Referring now to FIG. 4A, the assembly (trocar 20 and straight stylus 80) is advanced through soft tissue to the surface of the bone. Once the proper alignment is determined, the assembly is advanced through the cortical shell of pedicle 138 and into the cancellous interior 124 of the bone.

[0073] After the proper depth is achieved, the straight stylet 80 is removed from the trocar 20, while the trocar 20 remains stationary within the vertebrae 120. The straightening stylet 40 is inserted into proximal aperture 52 (see FIG. 2) of the curved cannula 50 and advanced along the central lumen of the curved cannula 50 until the stop 42 of the stylet 40 abuts up to the proximal end of the curved cannula. This forces the distal tip of the straight stylet through the curved section 56 of the curved cannula 50 to straighten out the curve 56. It is contemplated that the straight stylet comprise a hard, non-compliant material and the distal end 56 of the curved cannula 50 a compliant, yet memory retaining material (e.g. Nitinol, formed PEEK, etc.) such that the curved 56 section yields to the rigidity of the straightening stylet 40 when installed, yet retains its original curved shape when the stylet 40 is removed.

[0074] As shown in FIG. 4B, once the straightening stylet 40 is secure and the curved cannula 50 is straight, they are inserted into the needle trocar 20 and secured. Proper alignment (e.g. prevent rotation, orient curve direction during deployment) is maintained by aligning a flat on the upper portion 58 of the curved cannula 50 to an alignment pin secured perpendicularly into the needle

trocac 20 handle 24. Once the curved cannula 50 is secure, the straightening stylet 40 is removed, while the curved cannula 50 remains stationary within the trocac 20.

[0075] Referring to FIG. 4C, the curved stylet 60 is then straightened out by sliding the small tube 68 proximally to distally on its shaft towards the distal tip 64 or from the distal tip 64 proximally on its shaft towards the proximal end 62. Once the curved distal tip 66 is straightened out and fully retracted inside the small tube 68, the curved stylet 60 is inserted into the proximal aperture 52 of the curved cannula 50, which still resides inside the needle trocac 20. As the curved stylet 60 is advanced into the curved cannula 50, the small tube 68 is met by a stop 55 (see FIG. 4C). As the curved stylet 60 continues to advance the small tube 68 is held inside the handle of the curved cannula 50. This allows the curve of the stylet 60 to be exposed inside the curved cannula 50. To create the maximum force the curve of the two parts (50 & 60) must be aligned. To ensure alignment the cap on the curved stylet 60 has an alignment pin 70 which engages with alignment notch 52 on the proximal end of the curved cannula 50.

[0076] Once the stylet 60 is fully seated and aligned with the curved cannula 50 the tip of the curved stylet 60 will protrude from the tip of the curved cannula 50 by about 1/16 to 3/16 inches. This protrusion will help to drive the curve in the direction of its orientation during deployment.

[0077] Referring now to FIG. 4D, with the curved stylet 60 and the curved cannula 50 engaged, the locking nut 58 at the top of the curved cannula 50 is rotated counter clockwise to allow the cannula 50 and stylet 60 to be advanced with relation to the needle trocac 20 such that the proximal end 52 about against 58, advancing the curved cannula 50 and stylet 60 beyond the distal opening of trocac 20 to generate a curved path in the cancellous bone region 124. As the curved cannula 50 and stylet 60 are advanced they will preferably curve at a radius of 0.4 to 1.0 inches through cancellous bone and arc to an angle between 5 and 110 degrees. Once the curved cannula 50 and stylet 60 are deployed to the intended angle, the locking nut at the top of the

curved cannula 50 is engaged with the needle trocar 20 to stop any additional advancement of the curved stylet cannula assembly.

5 **[0078]** Referring to FIGS. 7A-7B illustrate the tip of the curved stylet 60, which has been formed with two angles. To help the curve deployment in the proper direction the curve 66 of the curved stylet 60 is shaped in a predetermined orientation. The angle on the inside of the curve 72 is less than the angle on the outside of the curve 74. This disparity in angle helps the stylet cannula assembly 50 & 60 curve in the bone as bone pushes against outside curve face 74 ensuring the curve radius is maintained during deployment.

10 **[0079]** Referring now to FIG. 4E, the curved stylet 60 is then removed and replaced by the channeling stylet 90. The tip 94 of the channeling stylet 90 is advanced beyond the end 54 of the curved cannula 50 towards the intended target treatment zone.

15 **[0080]** Referring now to FIG. 4F, once the channeling stylet 90 reaches the target treatment zone, it is removed creating a working channel 146. Channel 140 will generally have a first section 142 that crosses the cortical bone of the pedicle 138, followed by a curved path 144. These sections are occupied by curved cannula 50 such that a treatment device fed through the cannula 50 will have to follow the curve of the cannula 50 and not veer off in another direction. The channel may further comprise the linear extension 146 in the cancellous bone 124 to further advance the treatment device toward the treatment site T.

20 **[0081]** With the trocar 20 and curved cannula 50 still in place, a treatment device (e.g. treatment probe 100 shown in FIG. 2, with an active element 102 on the distal end 104 of elongate flexible catheter 110 is delivered to the target treatment location T to perform a localized treatment.

25 **[0082]** In a preferred embodiment, the active element 102 is delivered to the treatment site and activated to delivery therapeutic treatment energy. The treatment probe may comprise an RF delivery probe having bipolar electrodes 106 and 108 that deliver a therapeutic level of heating to stimulate or ablate the nerve 122.

30

[0083] It is appreciated that any number of treatment modalities may be delivered to the treatment site for therapeutic treatment. For example, treatment may be affected by monopolar or tripolar RF, ultrasound, radiation, steam, microwave, laser, or other heating means. Additionally, the treatment device may comprise a fluid delivery catheter that deposits an agent, e.g. bone cement, or other therapeutic agent, to the treatment site T. Alternatively, cryogenic cooling may be delivered for localized treatment of the BVN. Furthermore, treatment may be affected by any mechanical destruction and or removal means capable of severing or denervating the BVN. For example, a cutting blade, bur or mechanically actuated cutter typically used in the art of orthoscopic surgery may be used to affect denervation of the BVN.

[0084] In addition to or separate from treating the BVN, a sensor may be delivered to the region to preoperatively or postoperatively measure nerve conduction at the treatment region. In this configuration, the sensor may be delivered on a distal tip of a flexible probe that may or may not have treatment elements as well.

[0085] The goal of the treatment may be ablation, or necrosis of the target nerve or tissue, or some lesser degree of treatment to denervate the BVN. For example, the treatment energy or frequency may be just sufficient to stimulate the nerve to block the nerve from transmitting signal (e.g. signals indicating pain).

[0086] Once the treatment is complete, the probe 100 is withdrawn. The curved cannula 50 is then withdrawn into the needle trocar 20. The needle trocar 20 with the curved cannula 50 is then removed and the access site is closed as prescribed by the physician.

[0087] In the above system 10, the design of the curves 56 and 66 of the curved cannula 50 and curved stylet 60 is such that the flexible element (e.g. carrying the treatment device) can navigate through the angular range of deployment of the Nitinol tube of the curved cannula 50. The curved nitinol tube 50 allows the flexible element to navigate through a curve within bone without veering off towards an unintended direction. Cancellous bone density

varies from person to person. Therefore, creating a curved channel within varying density cancellous bone 124 will generally not predictably or accurately support and contain the treatment device as it tries to navigate the curved channel.

5 **[0088]** With the system 10 of the present invention, the treatment device 100 is deployed into the bone through the curved Nitinol tube of the curved cannula 50, which supports the element as it traverses through the curve. When it
10 departs from the tube, it will do so in a linear direction along path 146 towards the target zone. This allows the user to predictably and accurately deploy the treatment device towards the target zone T regardless of the density of the cancellous bone.

[0089] In some embodiments, a radius of curvature that is smaller than that which can be achieved with a large diameter Nitinol tube may be advantageous. To achieve this, the curved tube of the curved cannula 50 may
15 take one of several forms. In one embodiment, the tube 50 is formed from a rigid polymer that can be heat set in a particular curve. If the polymer was unable to hold the desired curve, an additional stylet (e.g. curved stylet 60) of Nitinol, or other appropriate material, may also be used in conjunction with the polymer tube to achieve the desired curve. This proposed combination of
20 material may encompass and number or variety of materials in multiple different diameters to achieve the desired curve. These combinations only need to ensure that the final outside element (e.g. trocar 20) be “disengageable” from the internal elements and have an inner diameter sufficient to allow the desired treatment device 100 to pass to the treatment
25 region T.

[0090] In an alternative embodiment, of the curved cannula 50 may comprise a Nitinol tube having a pattern of reliefs or cuts (not shown) in the wall of the tube (particularly on the outer radius of the bend). The pattern of cuts or reliefs would allow the tube to bend into a radius tighter than a solid tube could
30 without compromising the integrity of the tubing wall.

[0091] FIG. 5 illustrates a second embodiment of the system or kit 200 of the

present invention that may be used to reduce the number of steps required for the procedure. The second embodiment includes a needle trocar 20, straightening stylet 40, used with the needle trocar 20 and the curved cannula 50 to create the initial path through the soft tissue and cortical shell to allow access to the cancellous bone, curved stylet 60 used in conjunction with the curved cannula 50 to create the curved path within the bone/tissue, and channeling stylet 90 used to create a working channel for the probe beyond the end of the curved path created by the curved stylet.

[0092] In one method according to the present invention, the straightening stylet 40 is inserted into the curved cannula 50 and secured. In this embodiment, the straightening stylet 40 has a sharp tip 46 designed to penetrate bone. Once the straightening stylet 40 is secure and the curved cannula 50 is straight, they are inserted into the needle trocar 20 and secured. In this embodiment, the curved cannula 50 and straightening stylet 40 are inserted into the shaft 28 of the trocar 20 only as far as to have sharp tip 46 of the straightening stylet 40 protrude from the distal end 22 of the trocar 20. Proper alignment is maintained by aligning a flat on the upper portion of the curved cannula 50 with a pin secured perpendicularly into the needle trocar 20 handle.

[0093] Referring now to FIG. 6, once the curved cannula 50 is secure, the assembly (trocar 20, curved cannula 50, and straightening stylet 40) is advanced through soft tissue to the surface of the bone. After finding the proper alignment at the pedicle 138 of vertebrae 120, the assembly (trocar 20, curved cannula 50, and straightening stylet 40) is advanced through the cortical shell 128 and into the cancellous interior 124 of the bone.

[0094] After the proper depth is achieved, the straightening stylet 40 is removed. The curved stylet 60 is then straightened out by sliding the small tube 68 on its shaft towards the distal tip 64. The curved distal tip 66 is straightened out and fully retracted inside the small tube 68, and then the curved stylet 60 is inserted into the curved cannula 50 which still resides inside the needle trocar 20. Once the curved stylet 60 is inserted into the curved

cannula 50, the small tube 68 is met by a stop 55 (see FIG. 4C). As the curved stylet 60 continues to advance, the small tube 68 is held inside the handle of the curved cannula 50. This allows the curve of the stylet 60 to be exposed inside the curved cannula 50.

5 **[0095]** To create the maximum force, it is preferred that the curves of the two parts (50 & 60) are aligned. To ensure alignment the cap on the curved stylet 60 has an alignment pin, which engages with a notch on the top of the curved cannula 50.

[0096] When the stylet 60 is fully seated and aligned with the curved cannula 10 50, the tip of the curved stylet 60 will protrude from the tip of the curved cannula 50 by about 1/16 to 3/16 inches. This protrusion will help to drive the curved cannula 50 in the direction of its orientation during deployment. Once the curved stylet 60 and the curved cannula 50 are engaged, the lock nut at the top of the curved cannula 50 is rotated counter clockwise to allow the 15 cannula 50 and stylet 60 to be advanced with relation to the needle trocar 20 (as shown in FIG. 4D). As the curved cannula and stylet are advanced they generate a curved path toward the treatment location T. Once the curved cannula 50 and stylet 60 are deployed to the intended angle, the lock nut at the top of the curved cannula 50 is engaged with the needle trocar 20 to stop 20 any additional advancement of the curved stylet cannula assembly.

[0097] The curved stylet 60 is then removed and replaced by the channeling stylet 90. The channeling stylet 90 is advanced beyond the end of the curved cannula 50 (see FIG. 4E) towards the intended target treatment zone creating a working channel for the active element to be inserted. Once the channeling 25 stylet 80 reached the target treatment zone it is removed and replaced by the treatment device 100, which is delivered to the treatment site T and activated.

[0098] Once the treatment is complete, the treatment device 100 is withdrawn. The curved cannula 50 is then withdrawn into the needle trocar 20. The 30 needle trocar 20 with the curved cannula 50 is then removed and the access site is closed as prescribed by the physician.

[0099] FIGS.7A and 7B illustrate detail views of a Nitinol wire for the curved stylet 60 (proximal end not shown). The wire comprises a shaft 78 having constant diameter D and a length L_s that may vary according to the application and desired depth to the treatment location. The wire has a preformed distal tip that is curved to have a radius r that redirects the distal tip 64 at an angle Θ with the shaft. As shown in FIG. 7A, angle Θ is shown to be approximately 110° . However, it is appreciated that the preformed tip may have an angle ranging from a few degrees (slight deflection off axis), to up to 180° (e.g. directing back toward the proximal end).

5
10 **[00100]** As shown in FIG. 7B detailing the distal tip 64, the tip may have a distal extension L_T that extends away from the shaft 78. To promote channeling along a path that follows radius r , the distal tip 64 is configured with dual-plane bevels 74 and 72. Plane 74 is offset at angle β , and plane 72 is offset at angle α . This configuration of the leading- allows for the stylet and/or curved
15 cannula to travel through bone in a path correlating to the specified curve in the stylet and/or cannula.

[00101] In the example illustrated in FIGS. 7A and 7B, the curved stylet 60 has a shaft length L_s of approximately 3.6 in., diameter D of approximately 0.040 in., and a distal tip length L_T of 0.125 in., radius r of 0.40 in., and angle $\beta = 35^\circ$
20 and angle $\alpha = 31^\circ$. It should be noted that the above dimensions are for illustration only, and may vary depending on the anatomy an tissue type.

[00102] It is appreciated that all the above embodiments may be provided as a kit of instruments to treat different regions of the body. For example, the location, orientation and angle of the treatment device with respect to the
25 trocar 20 may be varied by providing a set of instruments at varying increments. This may be achieved by varying the curvature (56, 66) in the curved cannula 50 and curved stylet 60. The curvature may be varied by varying the radius of curvature r , the insertion depth (shaft length L_s and tip length L_T , and/or the final exit angle Θ with respect to the trocar 20 central
30 bore. Thus, the physician may select a different kit for treating a lumber spine segment as opposed to a cervical spine segment, as the anatomy will dictate

the path that needs to be channeled.

5 [00103] Thus, when treating different spine segments, a set out of the kit may be selected to match the vertebra (or other region being treated). For example, delivering the treatment device at or near the BVN junction for a lumbar vertebra may have a different angle than for a cervical vertebra, and may vary from patient to patient. The set may be selected from the kit intra-operatively, or from a pre-surgery diagnostic evaluation (e.g. radiographic imaging of the target region).

[00104] Tube in Windowed Tube

10 [00105] FIGS. 8-18B illustrate a system 201 for generating a curved path in bone according to the present invention. FIG. 8 shows a perspective view of system 201 in a configuration ready for deployment within a patient's body. System 201 comprises an introducer/ trocar 210 having a proximal end housing 202 coupled to an elongate delivery tube 204. The distal end tip 208
15 has a sharpened and/or beveled tip to facilitate entry into and delivery through at least a portion of a bony mass such as the vertebral body.

[00106] The proximal end of the assembly (drive nut 270), may comprise a hard, rigid material to allow the trocar 210 to be tapped into place with a mallet or the like.

20 [00107] The tube body 204 comprises a laterally positioned radial opening or window 212 disposed just proximal or at the distal tip 208. The window 212 provides radial access from the central channel 218 of tube 204 so that an instrument or probe (e.g. probe 250 distal end) may be delivered at an angle (e.g. non-axial) with respect to the tube axis or central channel 218.

25 [00108] FIG. 9 illustrates an exploded view of system 201 prior to delivery within a patient. While it is preferred that the trocar 210 is introduced to a location near the target treatment site as a whole assembly shown in FIG. 8, it is also appreciated that the trocar may be introduced to the location by itself, with the additional components being positioned once the trocar 210 is in place. In
30 such a configuration, a stylet (not shown) may be positioned down the central channel 218 of the trocar 204 so as to block the aperture 212 from bone

fragments or other tissue matter entering in channel 218. The stylet may have a hard, widened proximal end to allow the trocar 210 to be tapped into place.

[00109] The proximal end 206 of trocar housing 202 comprises a centrally-located, counter-bore or recess 216 that is in communication with trocar channel 218. Trocar recess 216 allows placement and reciprocation of curveable cannula 230 within the trocar recess 216 and trocar central channel 218. The curveable cannula 230 may be held in place at a specified location within the trocar recess 216 via a stop nut 240 that is threaded about proximal body 246 of the curveable cannula 230. The curveable cannula 230 also comprises a central recess 268 within proximal body 246 that is centrally aligned with cannula channel 245. Central recess 268 and cannula channel 245 are configured to receive and allow reciprocation of probe 250, which is threaded into drive nut 270.

[00110] FIGS. 10A-10E schematically illustrate the system 201 in various stages of deployment in accordance with the present invention. FIGS. 11, 13, 15 and 16 illustrate section views of the proximal end of system 201 through the various stages embodied in FIGS 10A-E. Correspondingly, FIGS. 12, 14, illustrate close-up views of the distal end of system 201 through various the stages embodied in FIGS 10A-E.

[00111] FIG. 11 illustrates a sectional view of the proximal end of system 201 in an un-deployed state prior to or during insertion of the trocar 210 to the desired treatment location in the patient. For delivery into a vertebral body 120 (e.g. to access the BVN), the trocar 210 may be delivered through pedicle 138 via channel 140 (as shown in FIG. 3). Channel 140 may be a pre-drilled hole, or may be generated by insertion of the sharpened tip 208 into the bone. To facilitate insertion, the proximal surface 292 of cap 290 of the drive nut 270 may comprise a rigid material (e.g. stainless steel or the like) so that a mallet or similar device may strike surface 292 to tap the trocar body 204 into place.

[00112] During insertion of the trocar 210, the stop nut 240 is threaded distally along external threads 248 of the proximal body 246 of the curveable cannula 230 to restrict motion of the cannula 230 distally down trocar recess 216. This

restrained motion keeps the distal end 232 of the cannula 230 from prematurely deploying while the trocar 210 is being delivered.

[00113] As shown in FIG. 12, the distal tip 233 of the curveable cannula 230 comprises a series of tubular mating links 234 each having a central bore to provide a continuous cannula channel 245 along with cannula tube 244. Cannula channel 245 extends from central cannula recess 268 of the proximal body 246 to the distal link 232 at tip 233. Distal link 232 comprises a beveled tip 233 to facilitate the curveable cannula 230 generating a path through bone as detailed below. Distal link 232 may also comprise a hard material, e.g. stainless steel or the like to provide a rigid leading edge for the curveable cannula 230.

[00114] The mating links 234 are held together with a cord 242 that runs from the proximal body 246 of the curveable cannula 230, and terminates at an aperture 236 in the distal link 232. The distal end of cord 242 terminates at a ball 238 that is disposed in a counter-bore, countersink, or like retaining surface of the aperture 236 to retain the cord within the distal link 232.

[00115] Referring now to FIG. 10B, once the trocar 210 is in place, stop nut 240 is threaded proximally along external threads 248 of the proximal end 246 of the curveable cannula 230 to allow motion of the cannula 230 distally downward in recess 214.

[00116] The proximal body 246 of curveable cannula 230 may then be deployed downward within trocar recess 216, as shown in section view in FIG. 13. As there may be resistance from the bony mass of the vertebral body (or other bony mass), the cannula 230 may be tapped downward by striking the proximal surface of cap 290 (e.g. with a mallet or the like) while holding the trocar at housing 202. The motion of proximal body 246 pushes tube 244 distally within channel 218 of the trocar body 204. This forces the leading edge 232 and trailing mating links 234 out of the radial window 212 in tube 204, as shown in FIG. 14. The distal end of opening or window 212 comprises a ramp 209 to facilitate the leading edge 232 out the window 212 at the proper angle with respect to the trocar tube 204 central axis, and without catching or

getting stuck at the distal end of the trocar.

[00117] In addition to the ramp 209, the curved path of the distal tip 233 is facilitated by tension provided by cord 242, which forces the mating links 232, 234 to arch upon the applied tension. The cord 242 is coupled to male-threaded dial 212 (see FIG. 8) to act as a pull cord to apply said tension. The dial 212 may be turned clockwise or counterclockwise within internal - threaded arm 214 to increase or relieve the tension on the cord 242, thereby providing steering of the distal tip 233 while the curved cannula 230 is advanced down trocar body 204 and out window 212 (e.g. increased tension provides a sharper radius, decreased tension provides a more relaxed or no radius.)

[00118] Alternatively, cord 242 may comprise a memory material such as a Nitinol wire that fastens the tube 244 and links 232, 234 in a preformed curved-shape. The cord 246 in this configuration stretches to allow the curveable cannula 230 to be delivered into and stowed in a linear form within channel 218, and retracts when not restrained in channel 218 to drive a curved path when exiting window 212.

[00119] As shown in FIGS. 13 and 14, the curveable cannula 230 is fully deployed, with the proximal end 246 disposed at the bottom of recess 216, and the distal tip 233 in a deployed orientation forming a curved path (along with trailing links 234) through the bone at the treatment site. In this configuration, the probe 250 is restrained from axial motion (in the distal direction) with respect to the curved cannula 230, because it is threaded inside drive nut 270, which is restrained from distal motion by stop 258 in the proximal end 246.

[00120] As shown in FIG. 15, the drive nut 270 may be raised (proximally advanced out of cavity 268) with respect to the curveable cannula 230 and probe proximal body 254 by rotating the drive nut. The proximal body 254 of the probe 250 comprises a male thread 256 that mates with the female internal threads 262 in a distal recess of the drive nut 270. The thread pattern 256/262 may preferably be opposite of the thread pattern between the stop

nut 240 and proximal end 246 of the curveable cannula 230 (e.g. right-handed thread vs. left-handed thread), so that rotation of the drive nut 270 does not result in rotation of the curveable cannula 230.

5 **[00121]** Furthermore, the proximal end 254 of the probe 250 comprises a plurality of vertical grooves 264, at least one of which interfaces with key 266 of the curveable cannula 230. This interface only allows axial motion of the proximal body 264 with the curveable cannula 230, and restricts rotation of the proximal body 264 with the curveable cannula 230. Thus, rotation of the drive nut 270 only results in proximal translation of the drive nut 270. As seen in
10 FIG. 15, the probe proximal body 254 is now free to move downward in cavity 268.

[00122] Referring now to FIGS. 16 and 17, the system 201 is shown in a fully deployed state, with the probe 250 distal shaft advanced beyond distal end 233 of the curveable cannula central channel 245. This is achieved by
15 advancing the proximal body 254 within the cavity 268 of the curveable cannula 230. The proximal body 254 and drive nut 270 are advanced as a unit within cavity 268, preferably by tapping the cap 290, thereby providing an impact force to advance the probe tip 274 out of the cannula 230 and through tissue/bone to reach the desired treatment or diagnostic location within the
20 body.

[00123] In an alternative embodiment, a channeling stylet (such as stylet 90 shown in kit 10 of FIG. 1) may also be used to create a working channel beyond the end of the curved path created by the curveable cannula 230 prior to deploying a probe for treatment or diagnostic device.

25 **[00124]** Once the distal tip 274 of the probe 250 is positioned at the desired location, treatment of the target tissue may be performed. As shown in FIG. 17, probe distal end 274 may comprise a first electrode 274 configured to deliver a therapeutic amount of RF energy to the target location. In the configuration shown in FIG. 17, the probe preferably comprises a bipolar probe with return electrode 276, however it is appreciated that the probe 250
30 may comprise any treatment instrument described herein.

[00125] Cap 290 may further be configured to include (e.g. a self contained unit) a power source (e.g. battery) and receptacles (not shown) to couple to the probe 250, thereby supplying the energy to deliver a therapeutic level of energy to the tissue. In this configuration, the cap 290 may have sufficient
5 power to deliver one or more metered doses of energy specifically measured to denervate the BVN of a vertebral body in accordance with the present invention.

[00126] The cap 290 is preferably threaded (or otherwise releasable coupled) into drive nut 270 to be interchangeable depending on the application or step
10 the procedure of the present invention. For example, a cap 290 having a reinforced/hardened surface 292 used for driving the system 201 into the bone may be replaced by another cap having couplings (not shown) for probe 250, an internal power supply (not shown), or couplings for an external power supply/controller (not shown) for delivering energy for treatment and/or
15 diagnosis of a region of tissue. For embodiments wherein a fluid and/or agent is delivered to the target tissue, the cap 290 may be configured to facilitate delivery of the fluid through a probe having one or more fluid delivery channels.

[00127] FIGS. 18A and 18B are side views of the distal end of the system 201
20 with the curveable cannula 230 in a stowed and deployed position respectively. The distal link 232 and trailing links 234 are configured to have mating/interlocking surfaces that allow the distal end of the cannula to curve in one direction. The more distal link of a mating pair will have an extension 235 that mates with a correspond depression 237 in the link proximal to it. This
25 allows the links to rotate with respect to each other to create a curved distal end as shown in FIG. 18B.

[00128] FIGS. 19A and 19B illustrate an alternative system 300 for generating a curved channel through bone. System 300 comprises a tubular trocar body
30 302, the proximal end (not shown) of which may comprise a portion or all of any of the previously described proximal ends for devices 10, 200, or 201 disclosed herein. The distal tip 334 comprises a leading edge surface for

advancing through bone, and a radial or lateral window 304 allowing access to the central channel of the trocar body 302. The window 304 is positioned a short distance proximal to the distal tip 334.

[00129] A curveable cannula 322 is positioned in the trocar 302, the curveable
5 cannula 322 having a distal end 324 coupled via linkage 326 to a pivotable
arm 310. The proximal end (not shown) of the curveable cannula may
comprise a portion or all of any of the previously described proximal ends for
devices 10, 200, or 201 disclosed herein. The pivotable arm 310 has a first
10 end pivotable coupled at joint 314 at a location at or near the distal tip 334 of
the trocar 302. In a stowed configuration (illustrated in FIG. 19A), the
pivotable arm is configured to lay axially in the trocar 302 within slot 306 that
runs from pivot 314 proximally to the radial opening or window 304. The
proximal (when stowed) end 312 of the arm 310 is coupled to the linkage 326.

[00130] As shown in FIG. 19B, the cannula 322 may be advanced laterally
15 outward from window 304 by simply advancing the cannula 322 distally down
the trocar 302. The pivotable arm 310 constrains the motion of the curveable
end 320 of the cannula to a curved path of specified radius (determined by the
length of arm 310. Once the pivotable arm has reached full rotation (shown
approximately 90 degrees in FIG. 19B, however such angle may be specified
20 to be any desired amount), the cannula end 320 has created a curved path
outward from the trocar toward the desired treatment site. A probe, stylet or
similar device (such as curved stylet 60, channeling stylet 90, or probe 100 of
FIG. 1) may be positioned at the opening of the distal end 320 to facilitate
generating the curved bore without allowing tissue or bone to enter the
25 cannula. The probe, treatment/diagnostic device may then be routed through
the cannula end 320 to a region of tissue/bone that is off-axis from the trocar
body 302.

[00131] It is appreciated that the above systems 201, 300 may be provided as a
30 kit of instruments to treat different regions of the body. For example, the
location, orientation and angle of the treatment device with respect to the
trocar may be varied by providing a set of instruments at varying increments.

This may be achieved by varying the curvature in the curveable cannula (230, 320). The curvature may be varied by varying the radius of curvature, the insertion depth (shaft length and tip length), and/or the final exit angle with respect to the trocar central bore. Thus, the physician may select a different kit for treating a lumbar spine segment as opposed to a cervical spine segment, as the anatomy will dictate the path that needs to be channeled.

[00132] It is appreciated that each of the instruments in the systems 10, 200, 201, and 300 detailed above may have any length, shape, or diameter desired or required to provide access to the treatment/diagnostic region (e.g. intraosseous nerve trunk) thereby facilitating effective treatment/diagnostic of the target region. For example, the size of the intraosseous nerve to be treated, the size of the passageway in the bone (e.g. pedicle 138) for accessing the intraosseous nerve, and the location of the bone, and thus the intraosseous nerve, are factors that that may assist in determining the desired size and shape of the individual instruments.

[00133] The systems 10, 200, 201 and 300 described above may be used with a number of different treatment modalities for therapeutic treatment of the target region. For example, in one embodiment, it is desirable to operate the treatment devices or probes in systems 100, 200, 20 and 300 in a manner that ablates the tissue of the target region (e.g. BVN) to produce heat as described in U.S. Patent No. 6,699,242, herein incorporated by reference in its entirety.

[00134] In another embodiment, the treatment device is configured to deliver therapeutic treatment that is targeted to block nerve conduction without ablating the nerve, i.e. thermal treatment is delivered to the nerve (e.g. via thermal therapy, agent or the like) that results in denervation of the BVN without necrosis of tissue. This may be achieved via delivery of a lesser amount of energy or agent to the tissue site (either in the form of less exposure time, concentration, intensity, etc.) than is required for ablation, but an amount sufficient to achieve some amount of temporary or permanent denervation.

[00135] It is further envisioned that the probed described herein may comprise

non-therapy devices, such as diagnostic devices (e.g. ultrasound, cameras, or the like) to diagnose a region of tissue independent of or in connection with treatment of the region of tissue.

5 [00136] It is also appreciated that individual elements of any of the systems 10
200, 201, and 300 detailed above may be used interchangeably where
applicable. For example, the curved stylet 60 shown in systems 10 and 200
may be temporarily implemented in place of the probe of systems 201 and 300
to provide additional curving bias to the curveable cannula (230, 320) while the
10 cannula is being driven into the bone. Furthermore, the channeling stylet 90
may be used to further generate a channel beyond the curved path provided
by the curveable cannula (230, 320)

[00137] As can be seen, therefore, the present invention includes the following
inventive embodiments among others:

15 [00138] 1. A system for channeling a path into bone, comprising: a trocar
having a proximal end, distal end and a central channel; wherein the central
channel is disposed along a central axis of the trocar and extends from the
proximal end toward the distal end; wherein the trocar comprises a radial
opening at or near the distal end of the trocar, the radial opening being in
communication with the central channel; and a curveable cannula sized to be
20 received in said central channel and delivered from the proximal end toward
said radial opening; the curveable cannula comprising a curveable distal end
configured to be extended laterally outward from the radial opening in a curved
path extending away from the trocar; wherein the curveable cannula
comprises a central passageway having a diameter configured allow a probe
25 to be delivered through the central passageway to a location beyond the
curved path.

[00139] 2. A system according to embodiment 1, wherein the trocar further
comprises a sharp distal tip configured to pierce through bone to generate a
linear path through bone.

30 [00140] 3. A system according to embodiment 2, wherein the curveable
cannula comprises a sharpened distal tip configured to pierce through bone to

generate a curved path extending from a linear path generated by the trocar.

5 [00141] 4. A system according to embodiment 1, wherein the distal end of the curveable cannula is deformable so as to be delivered in a straight configuration through the trocar and deployed in a curved configuration outward from the radial opening at an angle with respect to the central axis.

[00142] 5. A system according to embodiment 4, further comprising: a pull cord coupled to the distal tip of the curveable cannula, the pull cord extending to the proximal end of the trocar; wherein the pull cord is configured to apply a tensile force to the distal end of the curveable cannula to bias the curveable
10 cannula into a curved configuration.

[00143] 6. A system according to embodiment 5, wherein the tensile force applied to the distal tip of the curveable cannula may be controlled from the proximal end of the trocar to steer the curveable cannula along a desired path.

15 [00144] 7. A system according to embodiment 4, wherein a distal end of the curveable cannula comprises a plurality of mating links, the links configured to articulate into a curved shape.

[00145] 8. A system according to embodiment 4, wherein the central channel of the trocar terminates at a ramp leading to the radial window, said ramp facilitating deployment of said curveable cannula outward from said window.

20 [00146] 9. A system according to embodiment 1, wherein: the curveable cannula comprises a proximal end comprising a proximal body wherein the proximal end of the trocar comprises a housing: said housing having a proximal recess configured to allow reciprocation of the proximal body of the curveable cannula; wherein the proximal recess is in communication with the
25 central channel.

[00147] 10. A system according to embodiment 9, wherein a proximal body of the curveable cannula is configured to be releasably restrained with respect to translation within the trocar housing.

30 [00148] 11. A system according to embodiment 10, further comprising a probe sized to fit within the central channel of the cannula; the probe comprising a proximal end configured to be releasably restrained with respect to translation

within the cannula proximal body.

5 [00149] 12. A system according to embodiment 11, further comprising a drive nut coupled to the curveable cannula; wherein the drive nut comprises a hardened proximal surface suitable for applying an impact force to advance one or more of the trocar, curveable cannula, or probe through bone.

[00150] 13. A system according to embodiment 12, wherein the drive nut comprises a threaded distal recess configured to house the proximal end of the probe.

10 [00151] 14. A system according to embodiment 12, wherein the proximal surface of the drive nut comprises an interchangeable cap; said interchangeable cap configured to provide access to the probe for providing a therapeutic energy.

15 [00152] 15. A method for channeling a path into bone to a treatment location in the body of a patient, comprising: inserting a trocar into a region of bone near the treatment location; the trocar having a proximal end, distal end and a central channel disposed therebetween; wherein the trocar comprises a radial opening at or near the distal end of the trocar, the radial opening being in communication with the central channel; delivering a curveable cannula through said central channel and to said radial opening; and deploying the curveable cannula laterally outward from the radial opening in a curved path extending away from the trocar.

[00153] 16. A method according to embodiment 15, further comprising: delivering a treatment device through a central passageway in the curveable cannula to a treatment location beyond the curved path.

25 [00154] 17. A method according to embodiment 16, further comprising: delivering a therapeutic amount of thermal energy to the treatment location.

30 [00155] 18. A method according to embodiment 17, wherein inserting a trocar into a region of bone comprises: deploying the trocar through a cortical bone region and into a cancellous bone region of a vertebral body; wherein the curved path is generated though at least a portion of the cancellous bone region of the vertebral body.

[00156] 19. A method according to embodiment 16, further comprising:
steering the curveable cannula via a pull cord coupled to the distal tip of the
curveable cannula to bias the curveable cannula in the curved path.

5 **[00157]** 20. A method according to embodiment 18, wherein the treatment
location comprises a BVN associated with the vertebral body, the method
further comprising: delivering the thermal energy to the treatment location to
denervate at least a portion of the BVN.

10 **[00158]** 21. A spine therapy system, comprising: a trocar having a proximal
end, distal end and a central channel; wherein the central channel is disposed
along a central axis of the trocar and extends from the proximal end toward
the distal end; wherein the trocar comprises a radial opening at or near the
distal end of the trocar, the radial opening being in communication with the
central channel; wherein the trocar is configured to be deployed through a
15 cortical bone region and into a cancellous bone region of a vertebral body; a
curveable cannula sized to be received in said central channel and delivered
from the proximal end toward said radial opening; the curveable cannula
comprising a central passageway and curveable distal end configured to be
extended laterally outward from the radial opening in a curved path extending
20 away from the trocar; wherein the curved path is generated though at least a
portion of the cancellous bone region of the vertebral body; and a treatment
probe configured to be delivered through the central passageway to a location
beyond the curved path.

25 **[00159]** 22. A system according to embodiment 21, wherein the trocar further
comprises a sharp distal tip configured to pierce through bone to generate a
linear path through bone.

[00160] 23. A system according to embodiment 22, wherein the curveable
cannula comprises a sharpened distal tip configured to pierce through bone to
generate a curved path extending from a linear path generated by the trocar.

30 **[00161]** 24. A system according to embodiment 21, wherein the distal end of
the curveable cannula is deformable so as to be delivered in a straight
configuration through the trocar and deployed in a curved configuration

outward from the radial opening at an angle with respect to the central axis.

5 [00162] 25. A system according to embodiment 24, further comprising: a pull cord coupled to the distal tip of the curveable cannula, the pull cord extending to the proximal end of the trocar; wherein the pull cord is configured to apply a tensile force to the distal end of the curveable cannula to bias the curveable cannula into a curved configuration.

[00163] 26. A system according to embodiment 24, wherein a distal end of the curveable cannula comprises a plurality of mating links, the links configured to articulate into a curved shape.

10 [00164] 27. A system according to embodiment 21, wherein: the curveable cannula comprises a proximal end comprising a proximal body wherein the proximal end of the trocar comprises a housing: said housing having a proximal recess configured to allow reciprocation of the proximal body of the curveable cannula; and wherein the proximal recess is in communication with
15 the central channel.

[00165] 28. A system according to embodiment 27, wherein a proximal body of the curveable cannula is configured to be releasably restrained with respect to translation within the trocar housing.

20 [00166] 29. A system according to embodiment 28, wherein the probe comprises a proximal end configured to be releasably restrained with respect to translation within the cannula proximal body.

[00167] 30. A system according to embodiment 29, further comprising: a drive nut coupled to the curveable cannula; wherein the drive nut comprises a hardened proximal surface suitable for applying an impact force to advance
25 one or more of the trocar, curveable cannula, or probe through bone; wherein the drive nut comprises a threaded distal recess configured to house the proximal end of the probe; wherein the probe comprises mating threads with the distal recess so as to allow controlled translation of the probe with respect to the drive nut.

30 [00168] 31. A system according to embodiment 30, wherein the proximal surface of the drive nut comprises an interchangeable cap; said

interchangeable cap configured to provide access to the probe for providing a therapeutic energy.

[00169] Although the description above contains many details, these should not be construed as limiting the scope of the invention but as merely providing
5 illustrations of some of the presently preferred embodiments of this invention. Therefore, it will be appreciated that the scope of the present invention fully encompasses other embodiments which may become obvious to those skilled in the art, and that the scope of the present invention is accordingly to be limited by nothing other than the appended claims, in which reference to an
10 element in the singular is not intended to mean "one and only one" unless explicitly so stated, but rather "one or more." All structural, chemical, and functional equivalents to the elements of the above-described preferred embodiment that are known to those of ordinary skill in the art are expressly incorporated herein by reference and are intended to be encompassed by the
15 present claims. Moreover, it is not necessary for a device or method to address each and every problem sought to be solved by the present invention, for it to be encompassed by the present claims. Furthermore, no element, component, or method step in the present disclosure is intended to be dedicated to the public regardless of whether the element, component, or
20 method step is explicitly recited in the claims. No claim element herein is to be construed under the provisions of 35 U.S.C. 112, sixth paragraph, unless the element is expressly recited using the phrase "means for."

CLAIMS

What is claimed is:

1. A system for channeling a path into bone, comprising:
5 a trocar having a proximal end, distal end and a central channel;
wherein the central channel is disposed along a central axis of the trocar and extends from the proximal end toward the distal end;
wherein the trocar comprises a radial opening at or near the distal end of the trocar, the radial opening being in communication with the central channel; and
10 a curveable cannula sized to be received in said central channel and delivered from the proximal end toward said radial opening;
the curveable cannula comprising a curveable distal end configured to be extended laterally outward from the radial opening in a curved path extending away from the trocar;
15 wherein the curveable cannula comprises a central passageway having a diameter configured allow a probe to be delivered through the central passageway to a location beyond the curved path.
2. A system as recited in claim 1, wherein the trocar further comprises a
20 sharp distal tip configured to pierce through bone to generate a linear path through bone.
3. A system as recited in claim 2, wherein the curveable cannula
comprises a sharpened distal tip configured to pierce through bone to generate a
25 curved path extending from a linear path generated by the trocar.
4. A system as recited in claim 1, wherein the distal end of the curveable
cannula is deformable so as to be delivered in a straight configuration through the
trocar and deployed in a curved configuration outward from the radial opening at an
30 angle with respect to the central axis.

5. A system as recited in claim 4, further comprising:
a pull cord coupled to the distal tip of the curveable cannula, the pull cord
extending to the proximal end of the trocar;

5 wherein the pull cord is configured to apply a tensile force to the distal end of
the curveable cannula to bias the curveable cannula into a curved configuration.

6. A system as recited in claim 5, wherein the tensile force applied to the
distal tip of the curveable cannula may be controlled from the proximal end of the
10 trocar to steer the curveable cannula along a desired path.

7. A system as recited in claim 4, wherein a distal end of the curveable
cannula comprises a plurality of mating links, the links configured to articulate into a
curved shape.

15

8. A system as recited in claim 4, wherein the central channel of the trocar
terminates at a ramp leading to the radial window, said ramp facilitating deployment
of said curveable cannula outward from said window.

20

9. A system as recited in claim 1, wherein:
the curveable cannula comprises a proximal end comprising a proximal body
wherein the proximal end of the trocar comprises a housing:
said housing having a proximal recess configured to allow reciprocation of the
proximal body of the curveable cannula;

25

wherein the proximal recess is in communication with the central channel.

10. A system as recited in claim 9, wherein a proximal body of the
curveable cannula is configured to be releasably restrained with respect to translation
within the trocar housing.

11. A system as recited in claim 10, further comprising a probe sized to fit within the central channel of the cannula;

the probe comprising a proximal end configured to be releasably restrained with respect to translation within the cannula proximal body.

5

12. A system as recited in claim 11, further comprising a drive nut coupled to the curveable cannula;

wherein the drive nut comprises a hardened proximal surface suitable for applying an impact force to advance one or more of the trocar, curveable cannula, or probe through bone.

10

13. A system as recited in claim 12, wherein the drive nut comprises a threaded distal recess configured to house the proximal end of the probe.

15

14. A system as recited in claim 12, wherein the proximal surface of the drive nut comprises an interchangeable cap;

said interchangeable cap configured to provide access to the probe for providing a therapeutic energy.

20

15. A method for channeling a path into bone to a treatment location in the body of a patient, comprising:

inserting a trocar into a region of bone near the treatment location;

the trocar having a proximal end, distal end and a central channel disposed therebetween;

25

wherein the trocar comprises a radial opening at or near the distal end of the trocar, the radial opening being in communication with the central channel;

delivering a curveable cannula through said central channel and to said radial opening; and

30

deploying the curveable cannula laterally outward from the radial opening in a curved path extending away from the trocar.

16. A method as recited in claim 15, further comprising:
delivering a treatment device through a central passageway in the curveable cannula to a treatment location beyond the curved path.

5 17. A method as recited in claim 16, further comprising:
delivering a therapeutic amount of thermal energy to the treatment location.

18. A method as recited in claim 17, wherein inserting a trocar into a region
of bone comprises:
10 deploying the trocar through a cortical bone region and into a cancellous bone
region of a vertebral body;
wherein the curved path is generated though at least a portion of the
cancellous bone region of the vertebral body.

15 19. A method as recited in claim 16, further comprising:
steering the curveable cannula via a pull cord coupled to the distal tip of the
curveable cannula to bias the curveable cannula in the curved path.

20 20. A method as recited in claim 18, wherein the treatment location
comprises a BVN associated with the vertebral body, the method further comprising:
delivering the thermal energy to the treatment location to denervate at least a
portion of the BVN.

21. A spine therapy system, comprising:
25 a trocar having a proximal end, distal end and a central channel;
wherein the central channel is disposed along a central axis of the trocar and
extends from the proximal end toward the distal end;
wherein the trocar comprises a radial opening at or near the distal end of the
trocar, the radial opening being in communication with the central channel;
30 wherein the trocar is configured to be deployed through a cortical bone region
and into a cancellous bone region of a vertebral body;

a curveable cannula sized to be received in said central channel and delivered from the proximal end toward said radial opening;

the curveable cannula comprising a central passageway and curveable distal end configured to be extended laterally outward from the radial opening in a curved path extending away from the trocar;

wherein the curved path is generated though at least a portion of the cancellous bone region of the vertebral body; and

a treatment probe configured to be delivered through the central passageway to a location beyond the curved path.

10

22. A system as recited in claim 21, wherein the trocar further comprises a sharp distal tip configured to pierce through bone to generate a linear path through bone.

15

23. A system as recited in claim 22, wherein the curveable cannula comprises a sharpened distal tip configured to pierce through bone to generate a curved path extending from a linear path generated by the trocar.

20

24. A system as recited in claim 21, wherein the distal end of the curveable cannula is deformable so as to be delivered in a straight configuration through the trocar and deployed in a curved configuration outward from the radial opening at an angle with respect to the central axis.

25

25. A system as recited in claim 24, further comprising:

a pull cord coupled to the distal tip of the curveable cannula, the pull cord extending to the proximal end of the trocar;

wherein the pull cord is configured to apply a tensile force to the distal end of the curveable cannula to bias the curveable cannula into a curved configuration.

30

26. A system as recited in claim 24, wherein a distal end of the curveable cannula comprises a plurality of mating links, the links configured to articulate into a

curved shape.

27. A system as recited in claim 21, wherein:
the curveable cannula comprises a proximal end comprising a proximal body
5 wherein the proximal end of the trocar comprises a housing:
said housing having a proximal recess configured to allow reciprocation of the
proximal body of the curveable cannula;
wherein the proximal recess is in communication with the central channel.

10 28. A system as recited in claim 27, wherein a proximal body of the
curveable cannula is configured to be releasably restrained with respect to translation
within the trocar housing.

15 29. A system as recited in claim 28, wherein the probe comprises a
proximal end configured to be releasably restrained with respect to translation within
the cannula proximal body.

30. A system as recited in claim 29, further comprising:
a drive nut coupled to the curveable cannula;
20 wherein the drive nut comprises a hardened proximal surface suitable for
applying an impact force to advance one or more of the trocar, curveable cannula, or
probe through bone;
wherein the drive nut comprises a threaded distal recess configured to house
the proximal end of the probe; and
25 wherein the probe comprises mating threads with the distal recess so as to
allow controlled translation of the probe with respect to the drive nut.

31. A system as recited in claim 30, wherein the proximal surface of the
drive nut comprises an interchangeable cap;
30 said interchangeable cap configured to provide access to the probe for
providing a therapeutic energy.

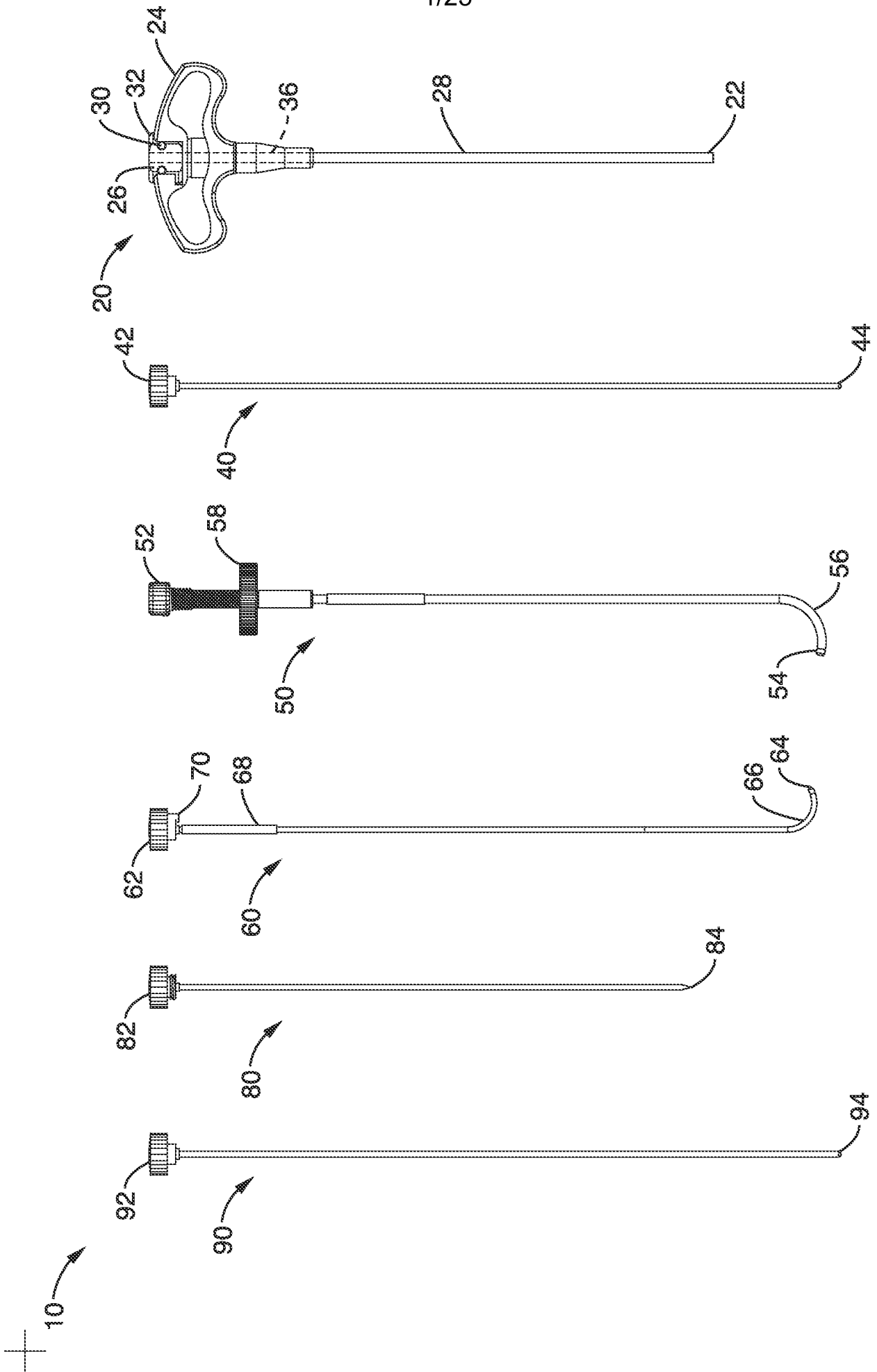

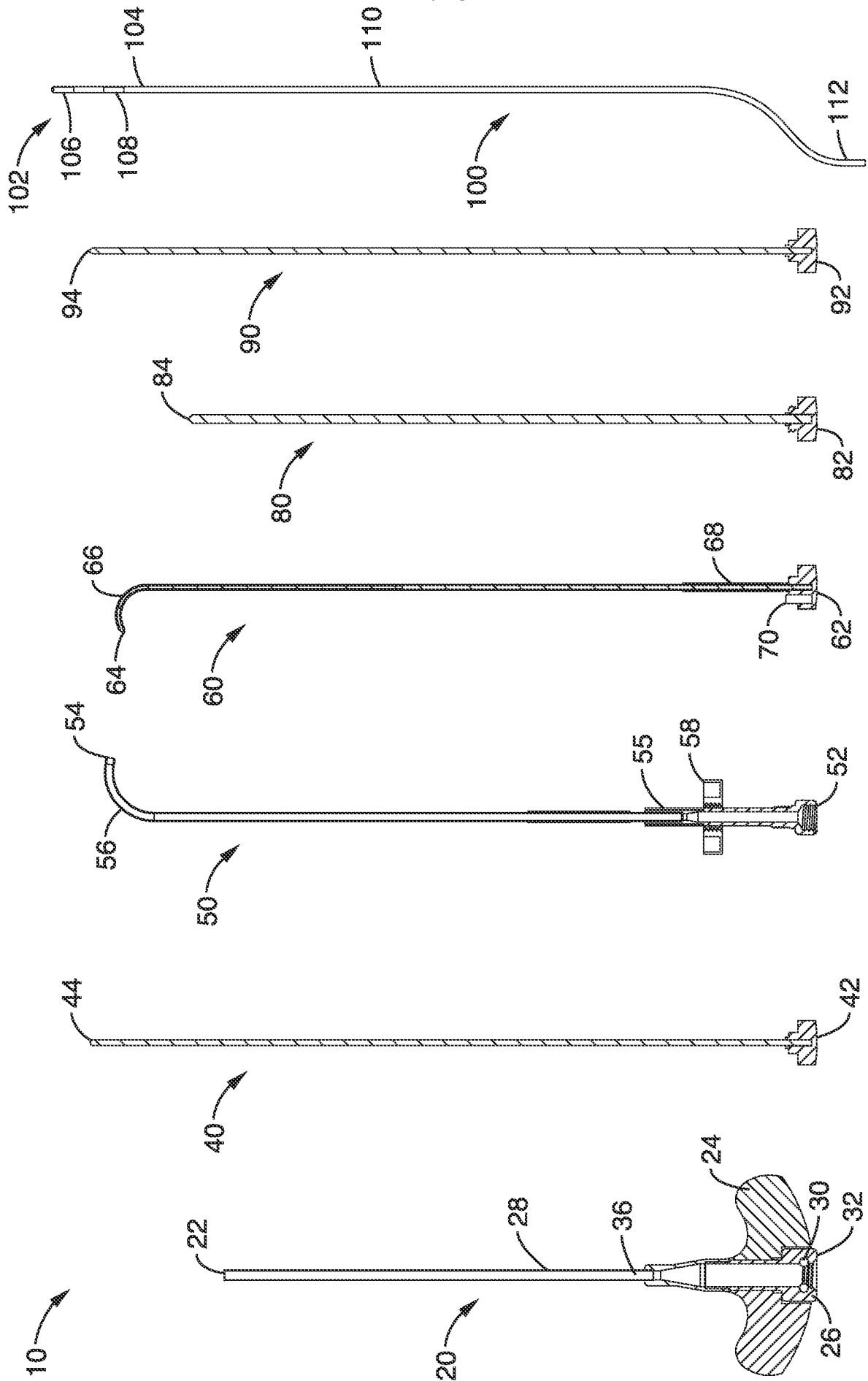

FIG. 2

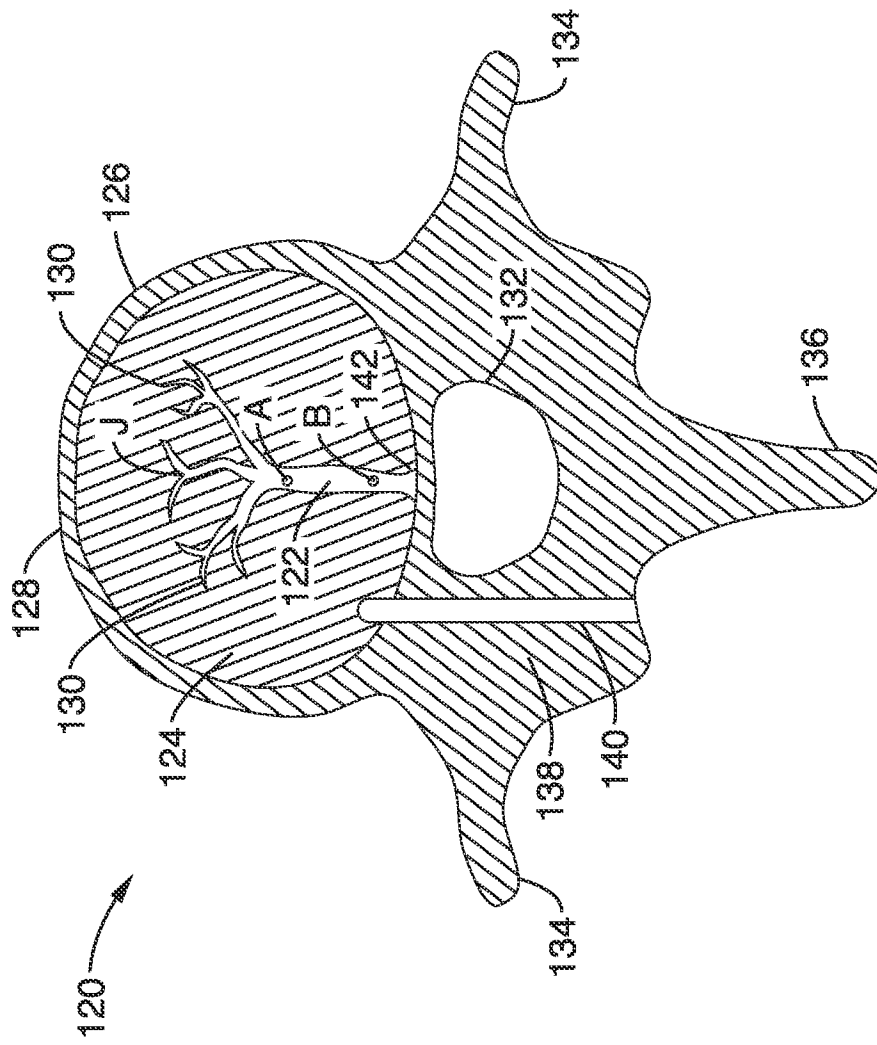
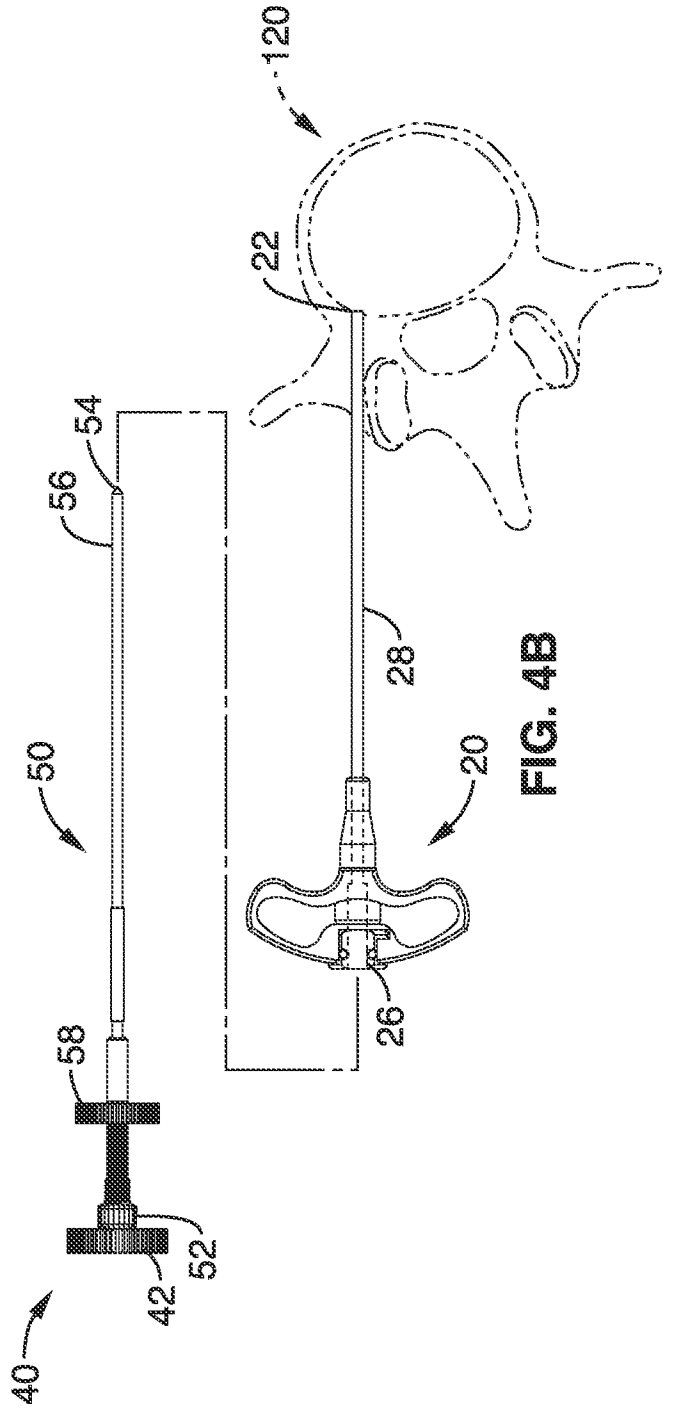
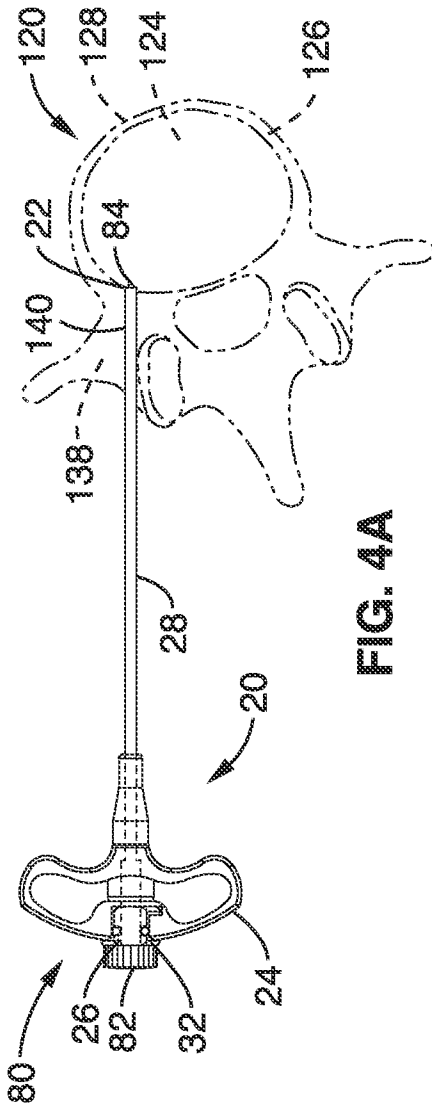

FIG. 3





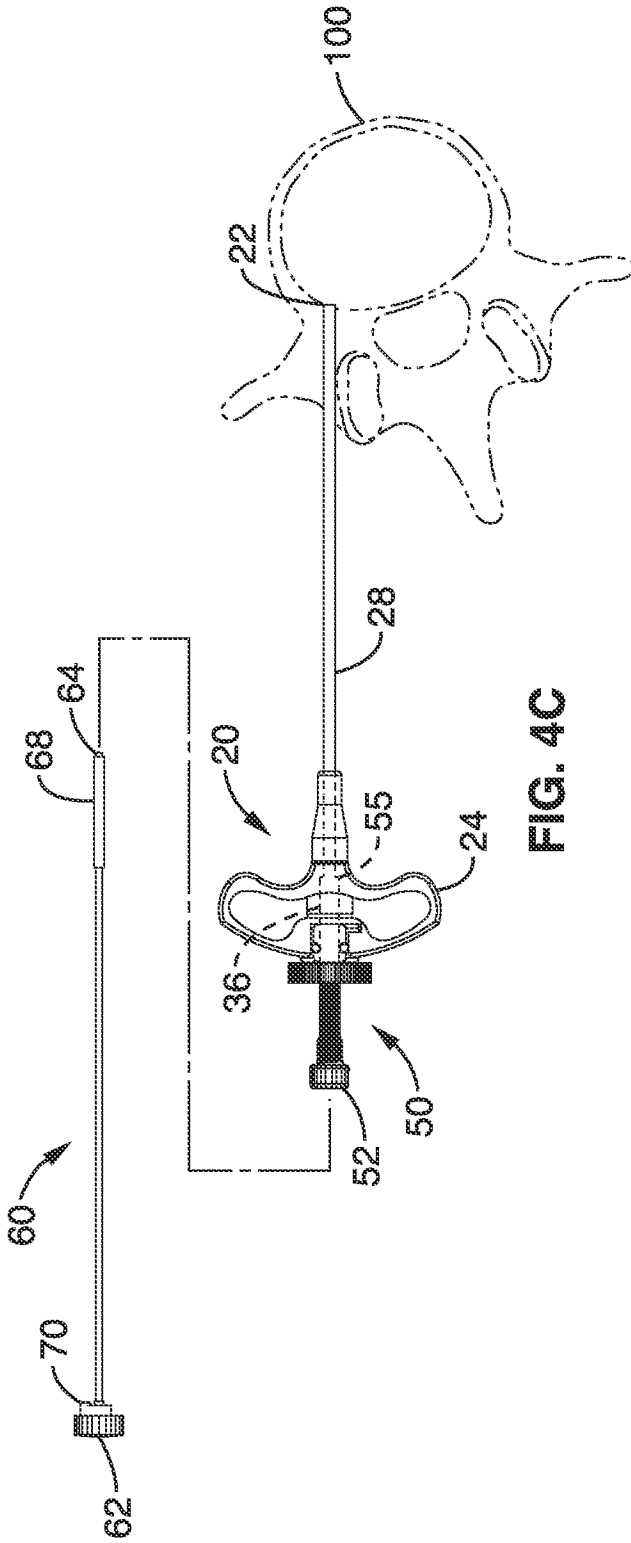

FIG. 4C

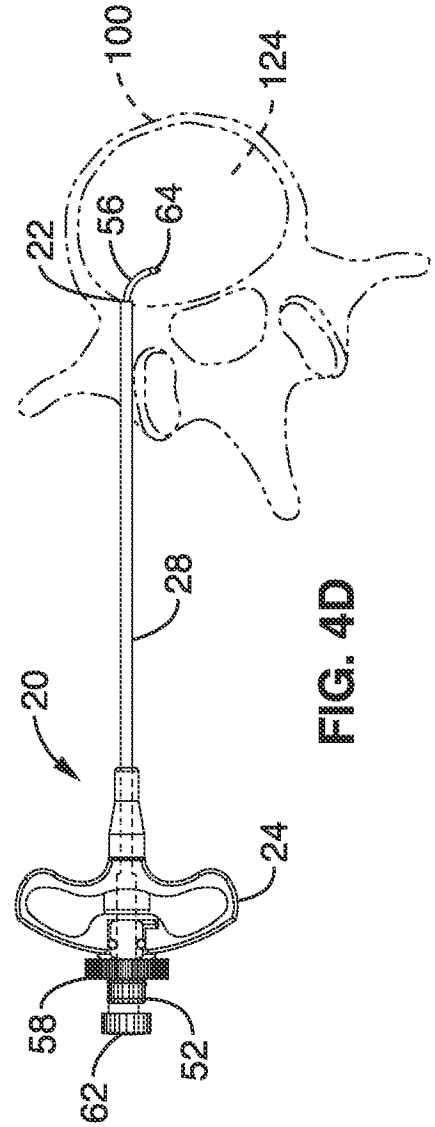

FIG. 4D



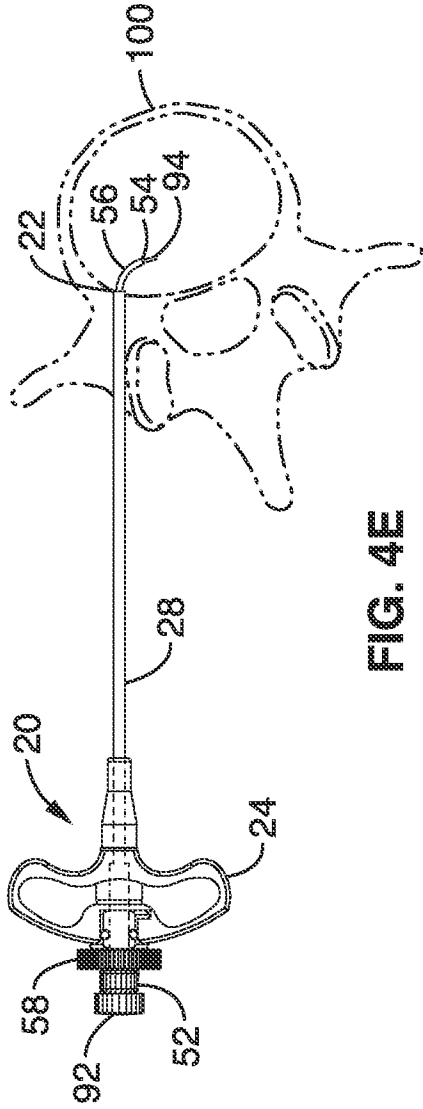

FIG. 4E

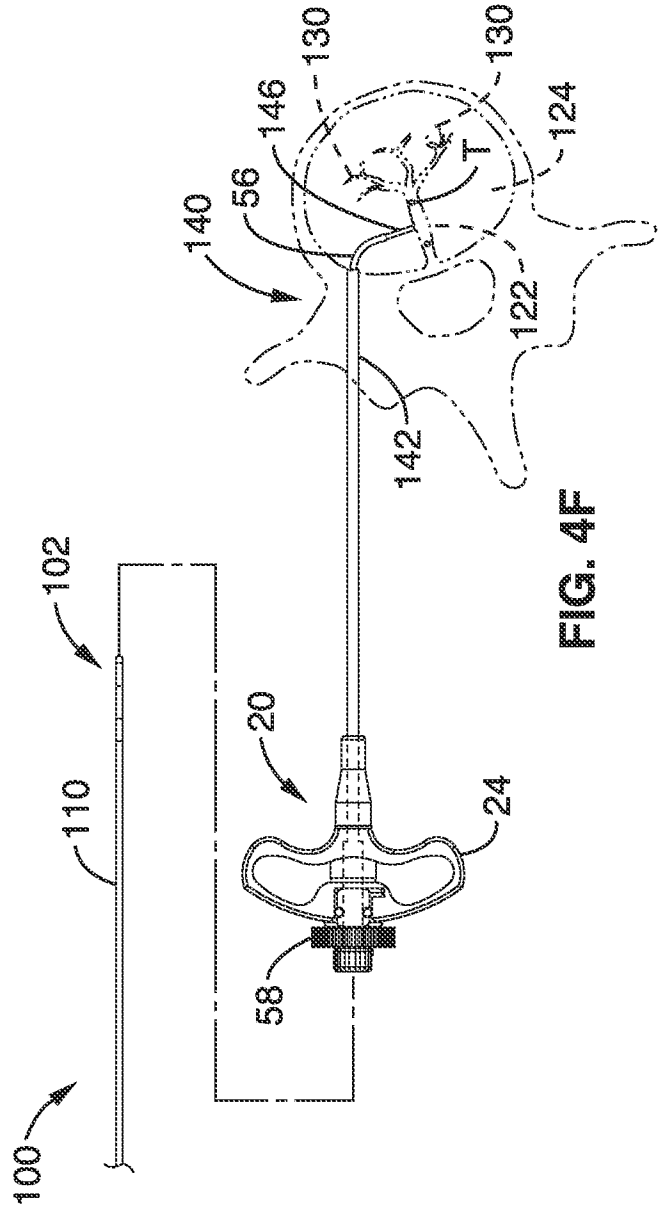

FIG. 4F

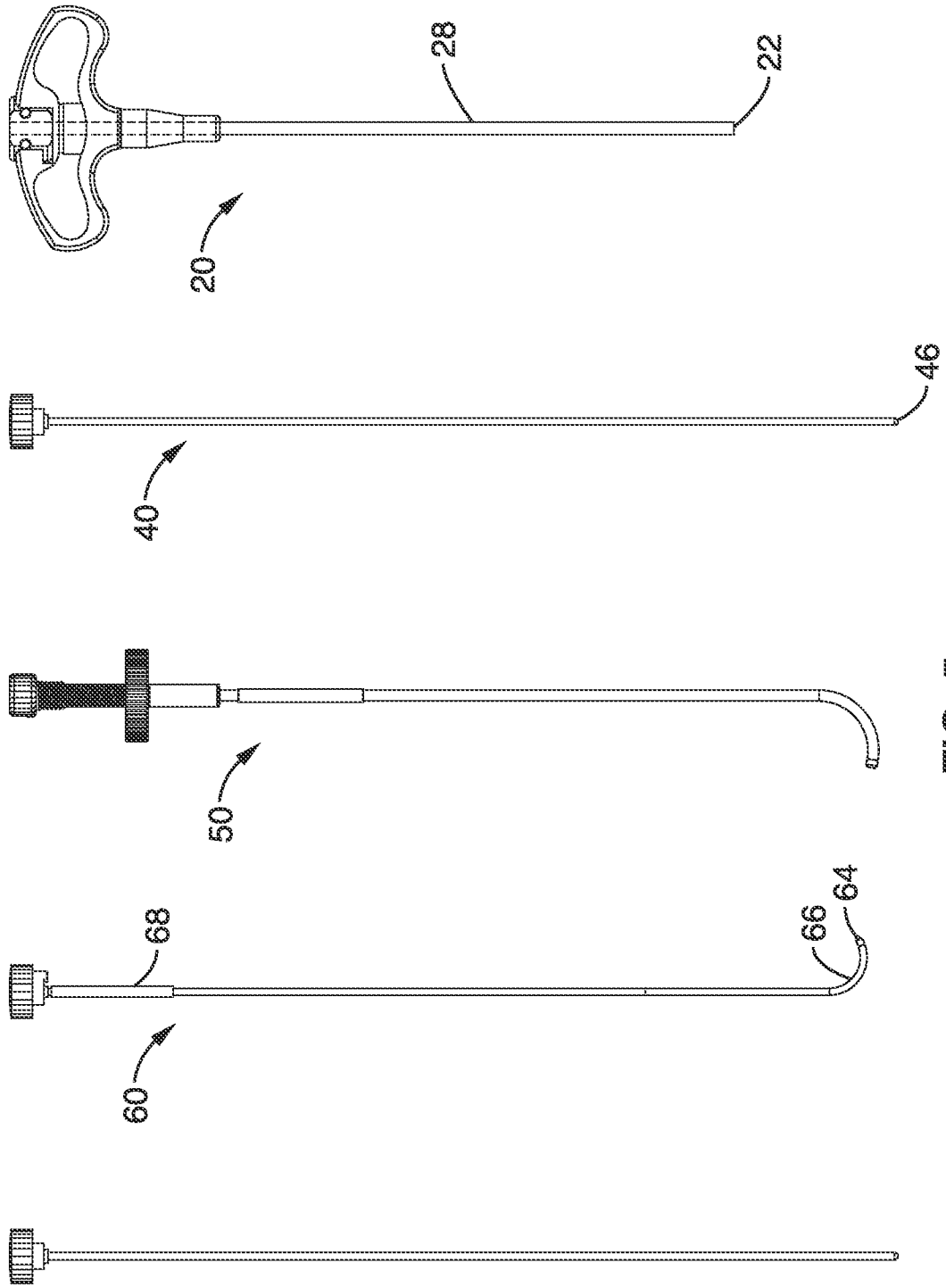

FIG. 5



200

90

60

68

50

40

46

22

28

20

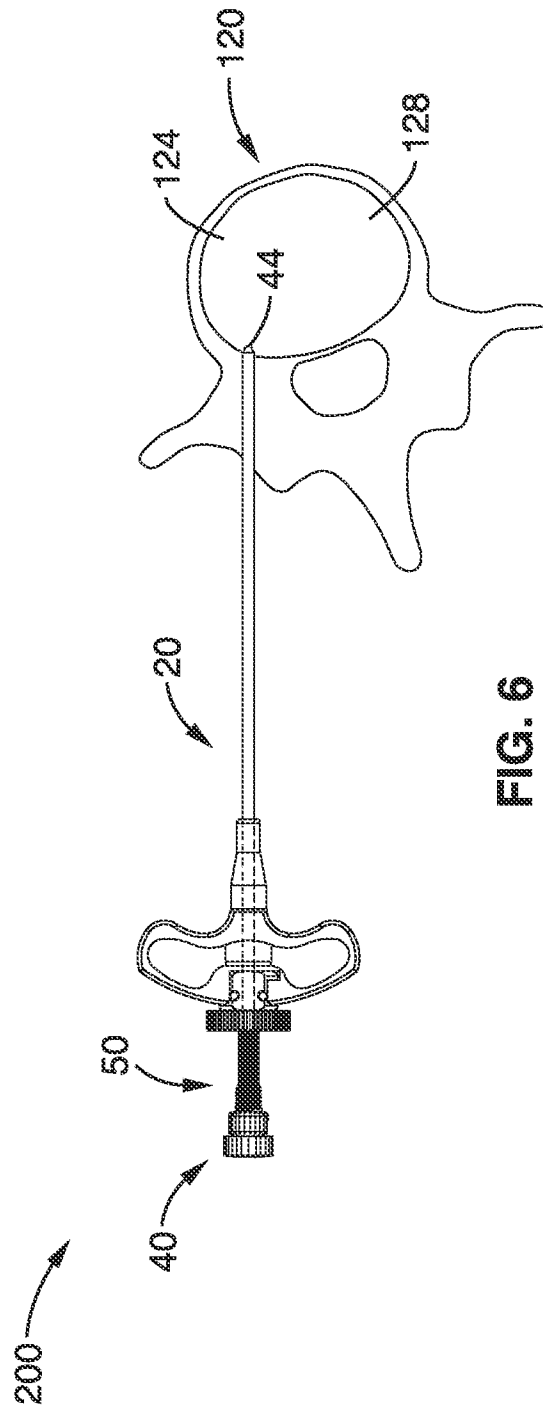

FIG. 6



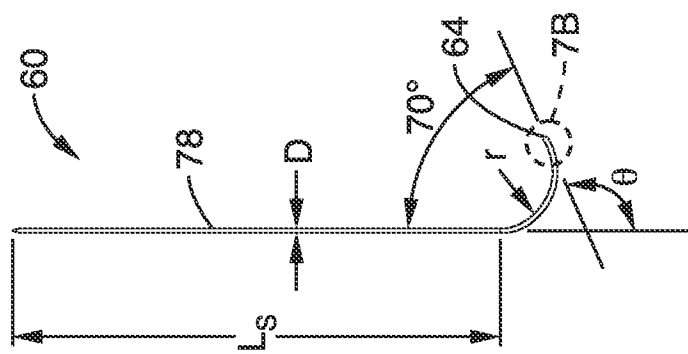

FIG. 7A

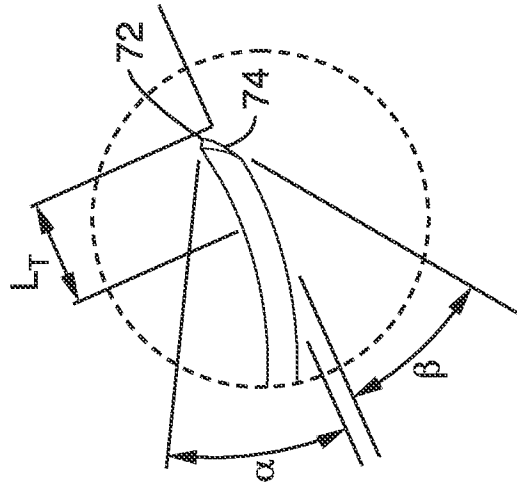

FIG. 7B



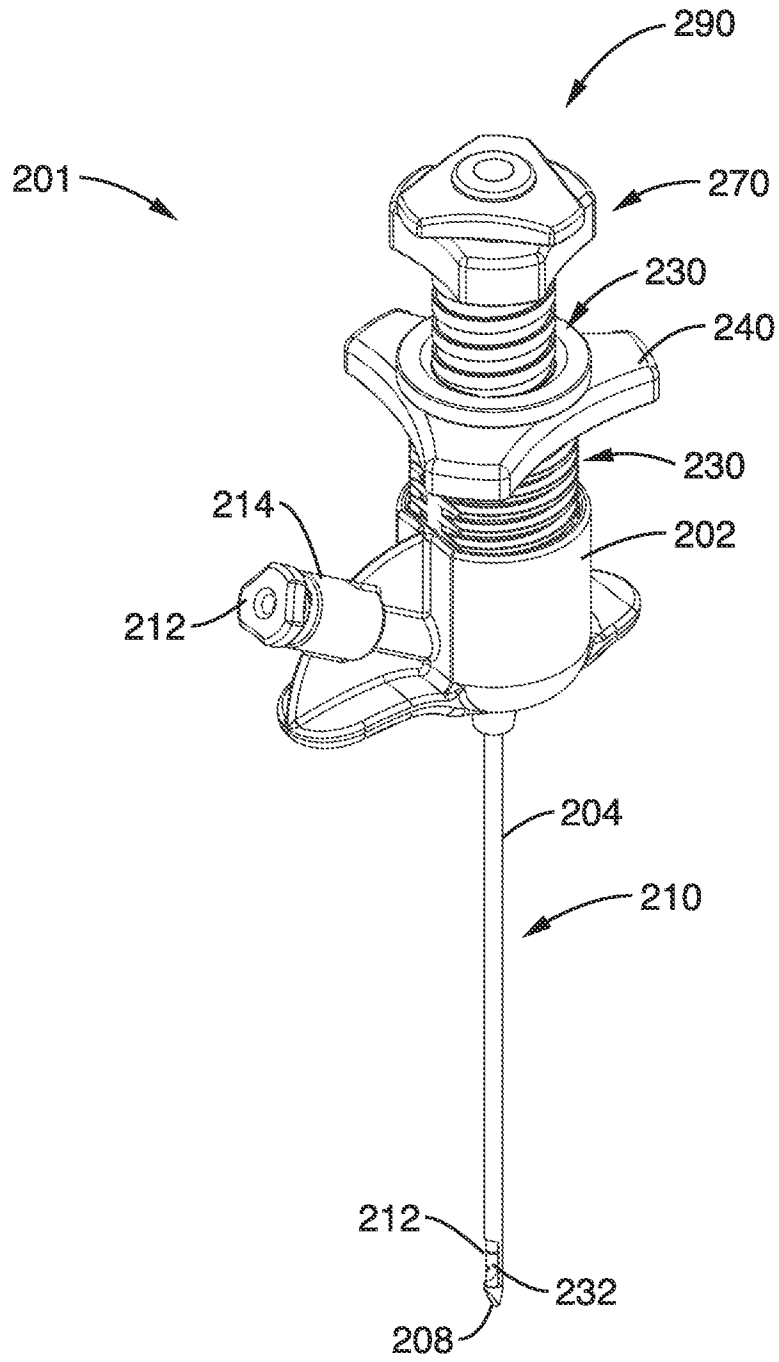

FIG. 8

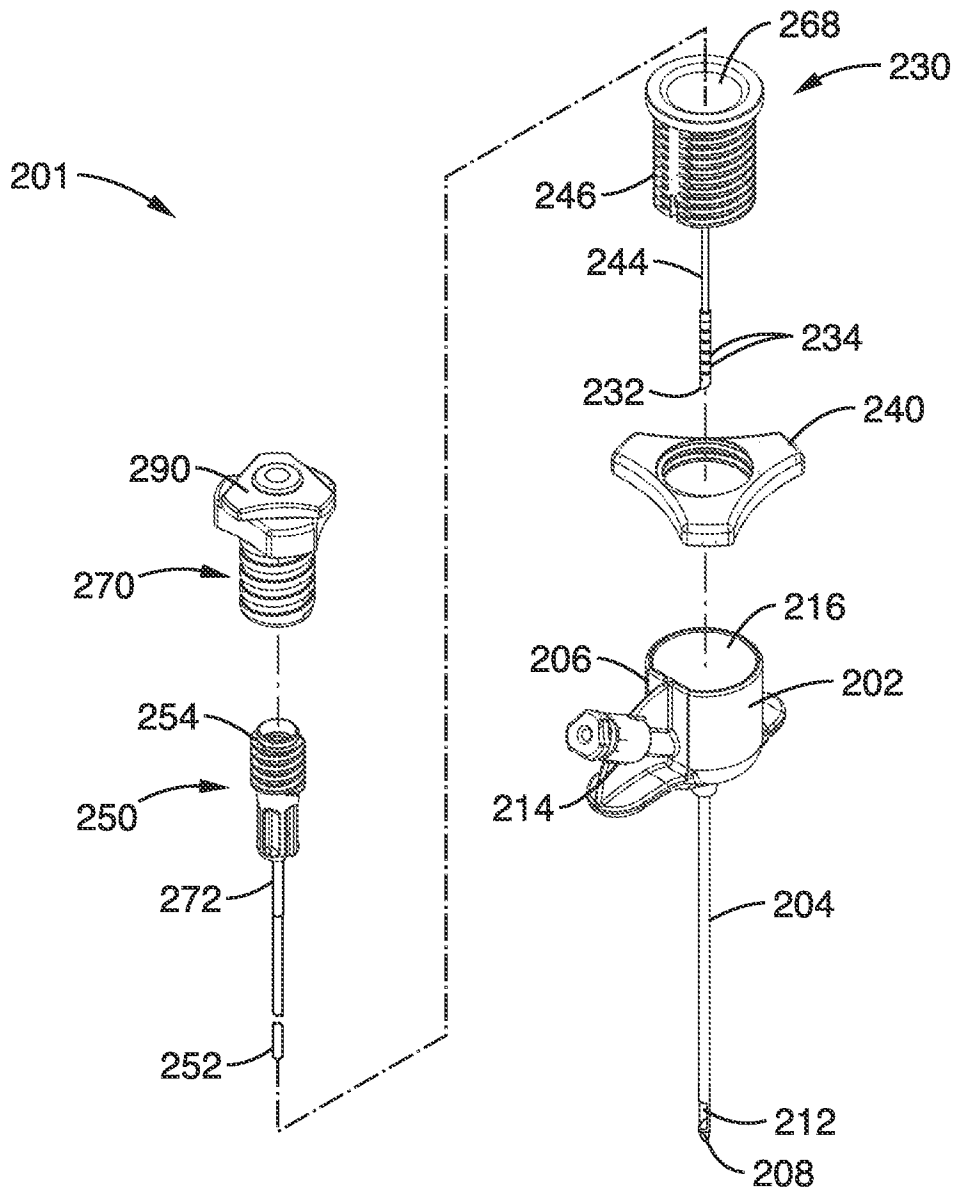
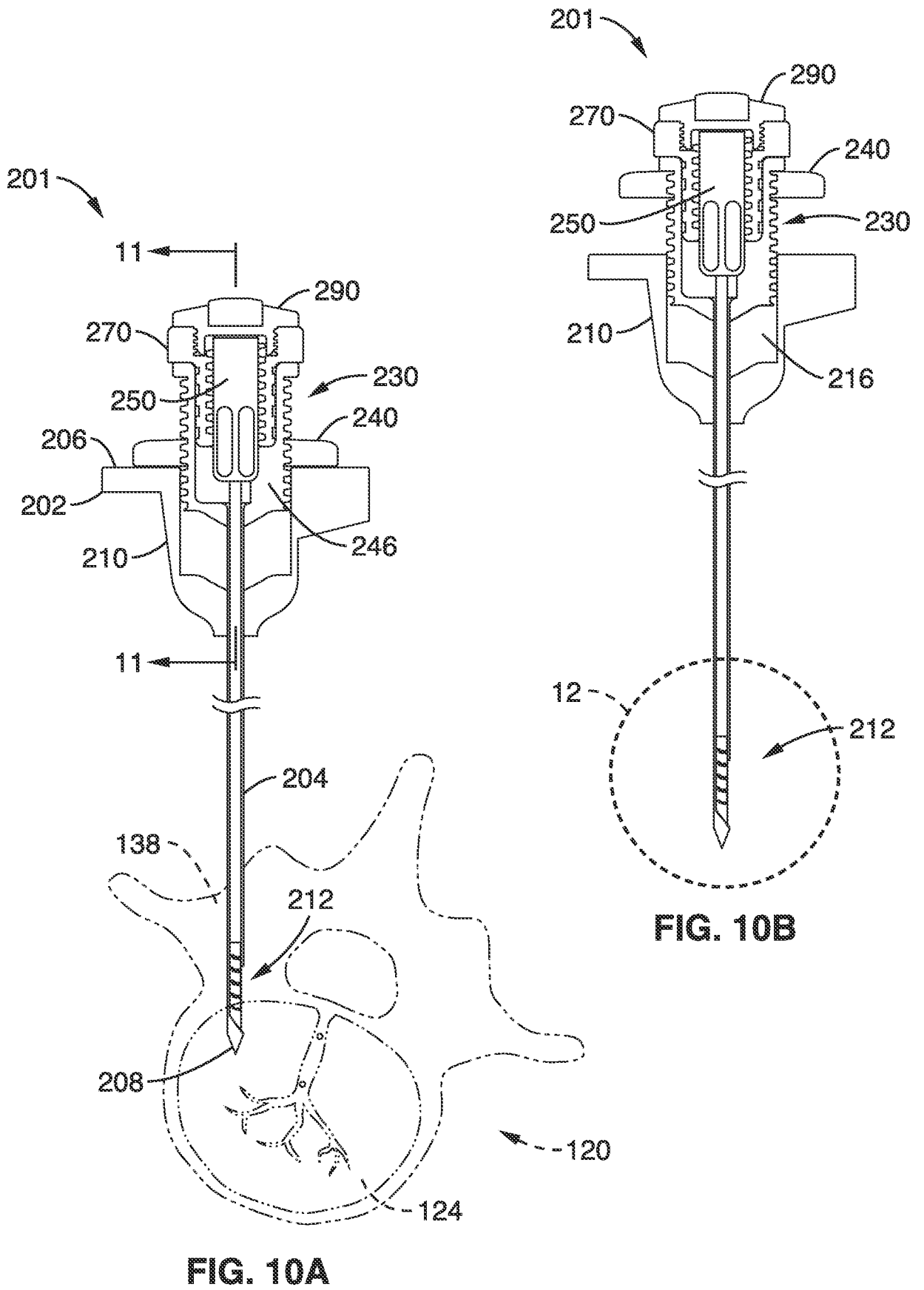

FIG. 9





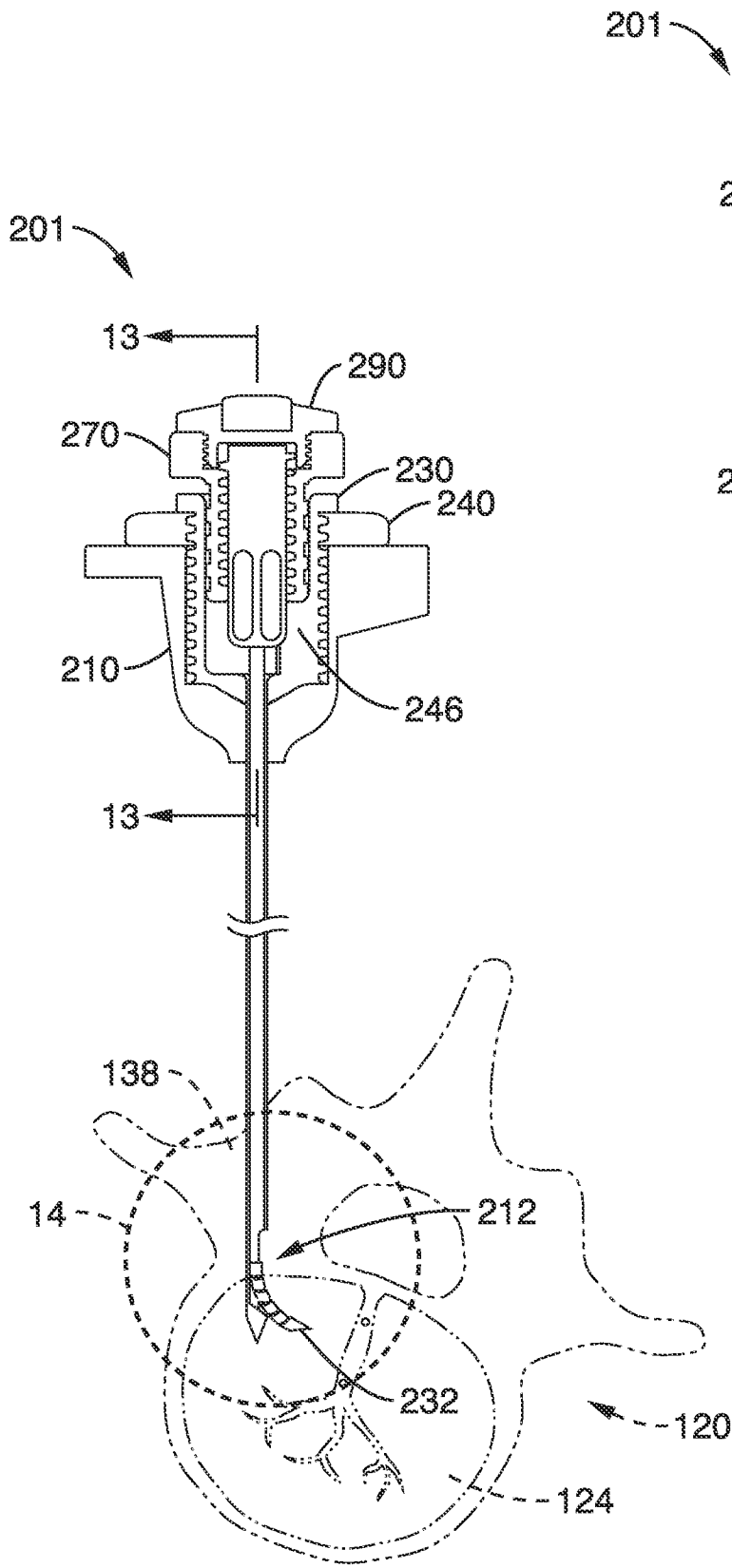

FIG. 10C

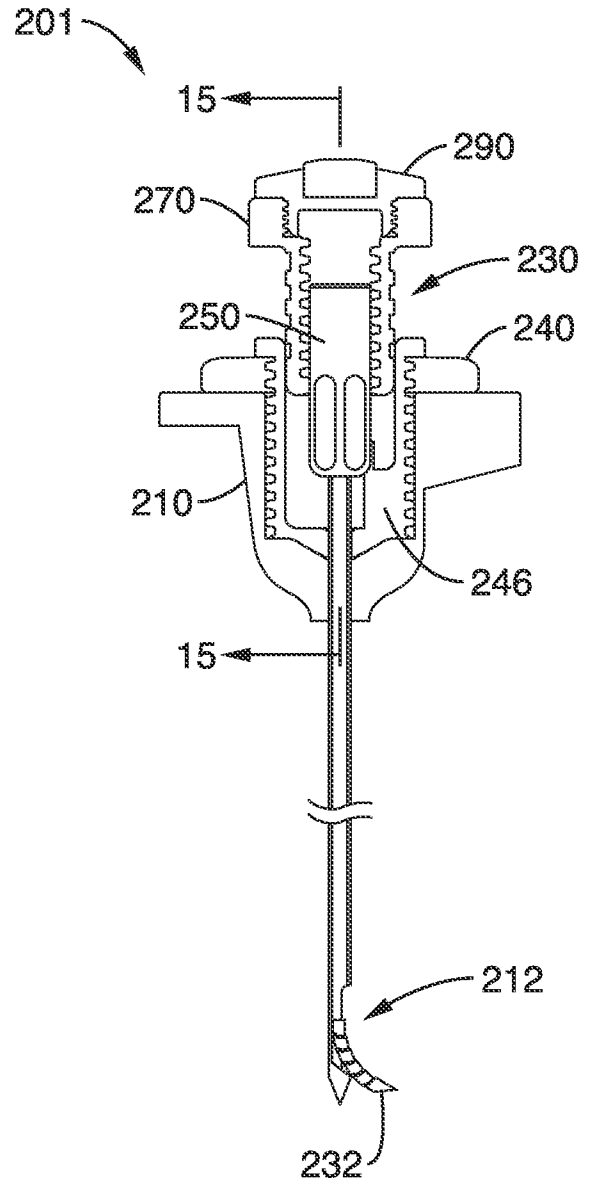

FIG. 10D



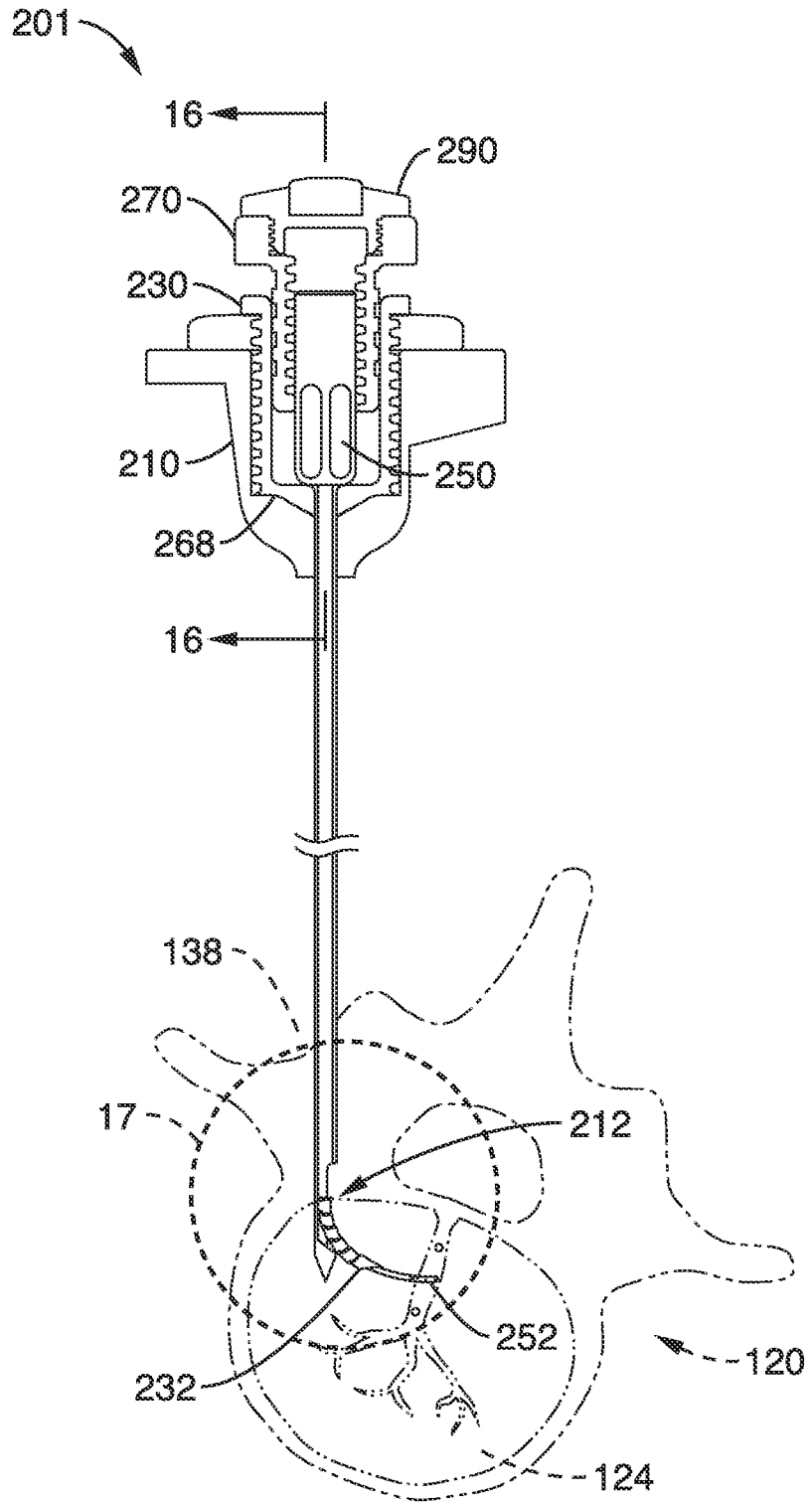

FIG. 10E

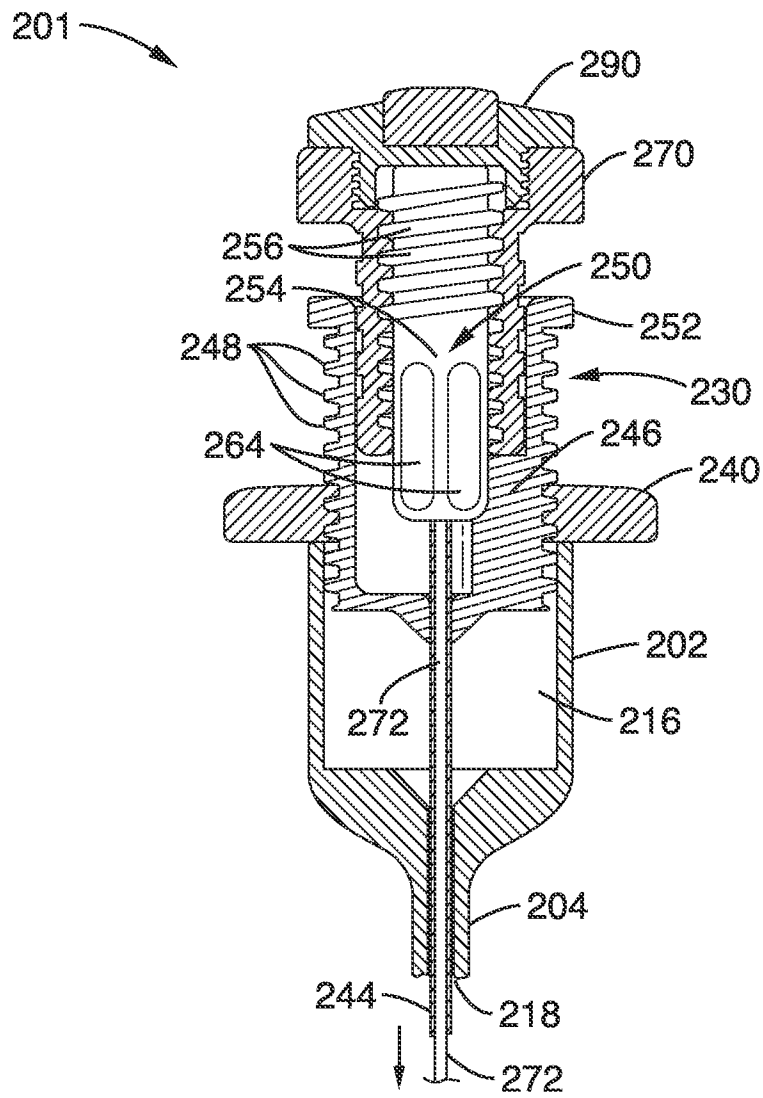

FIG. 11



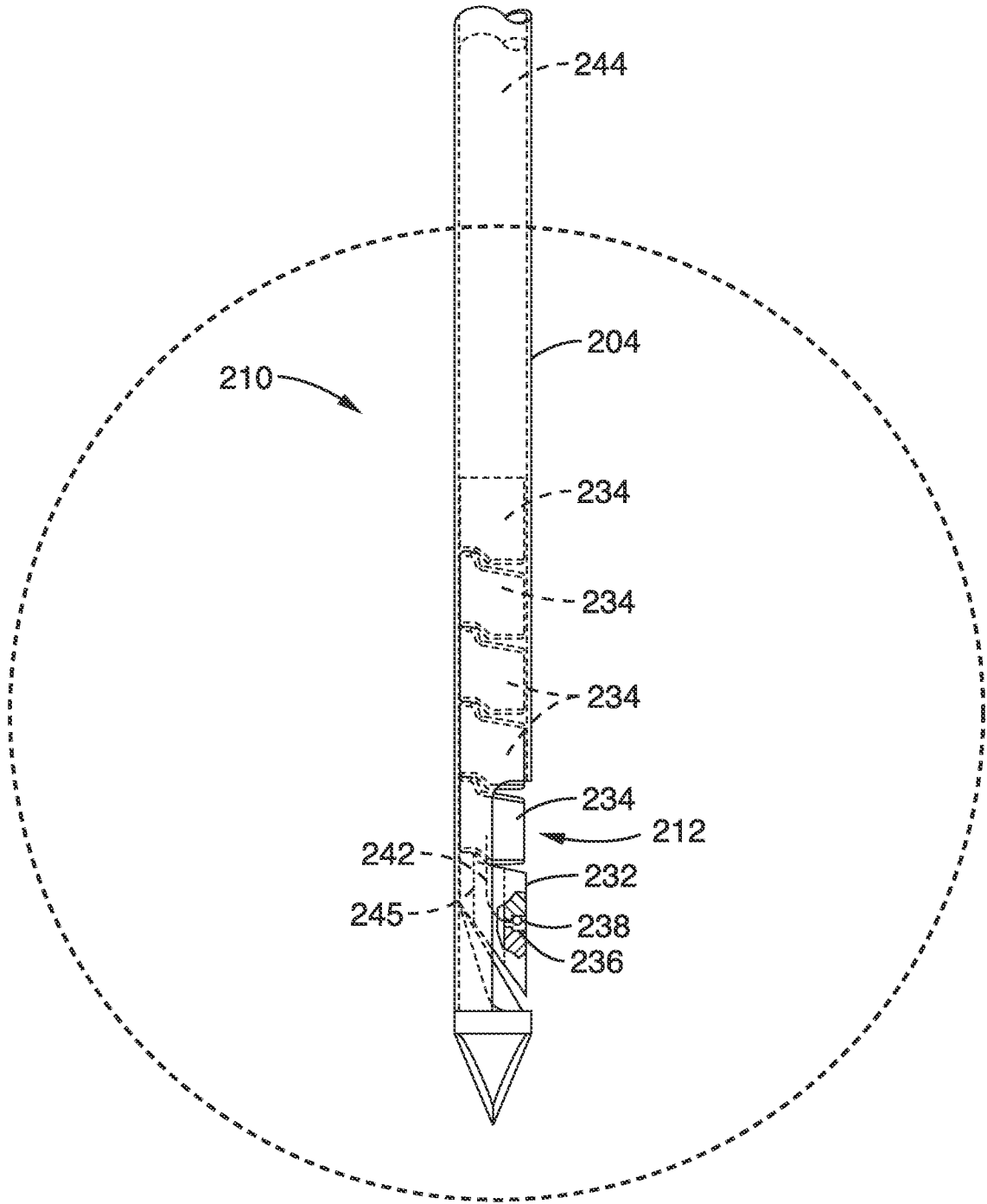

FIG. 12

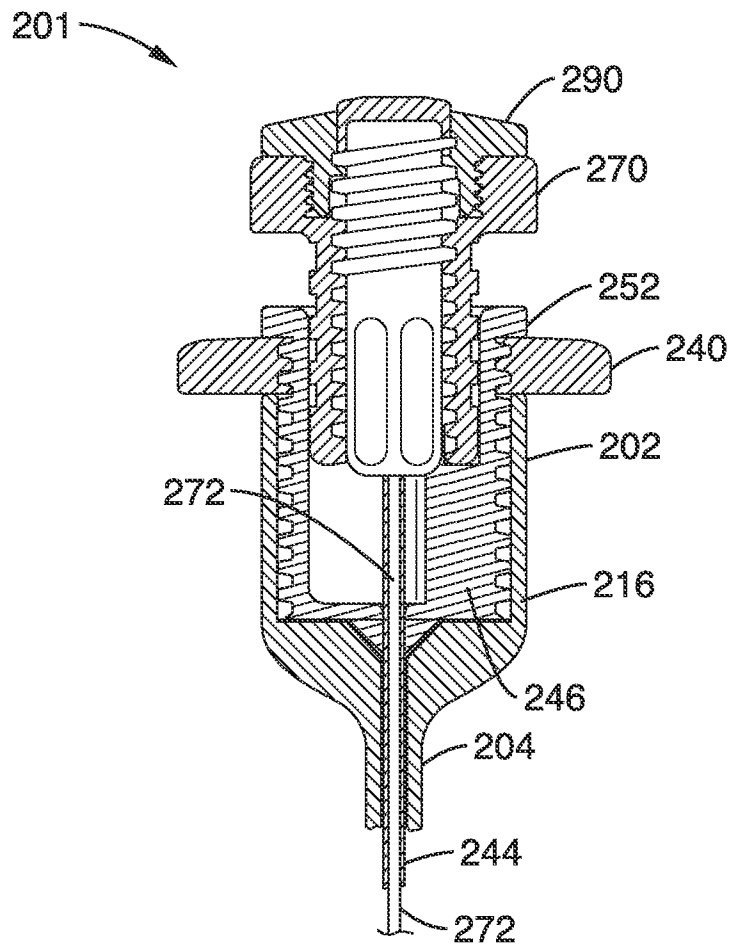

FIG. 13



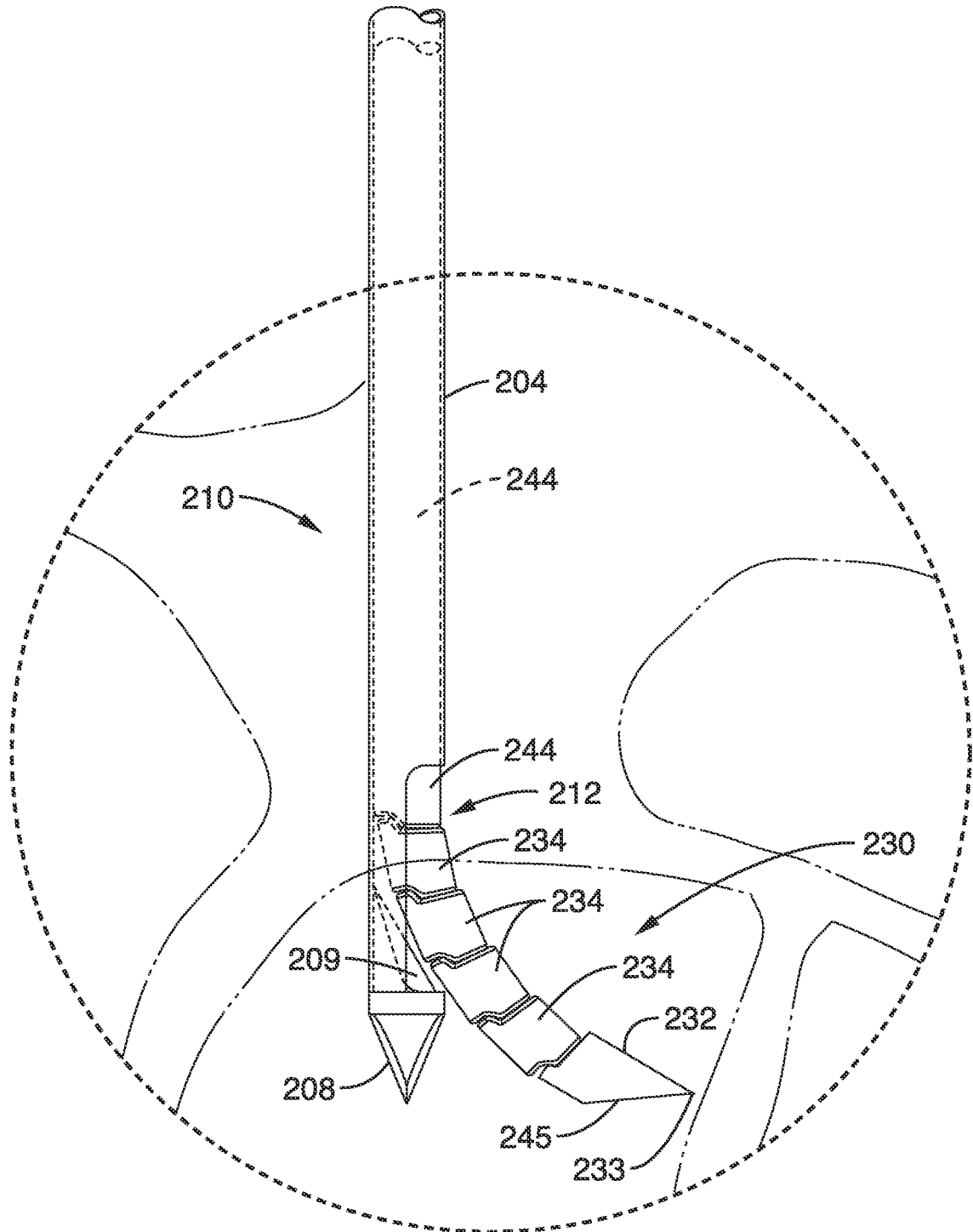

FIG. 14



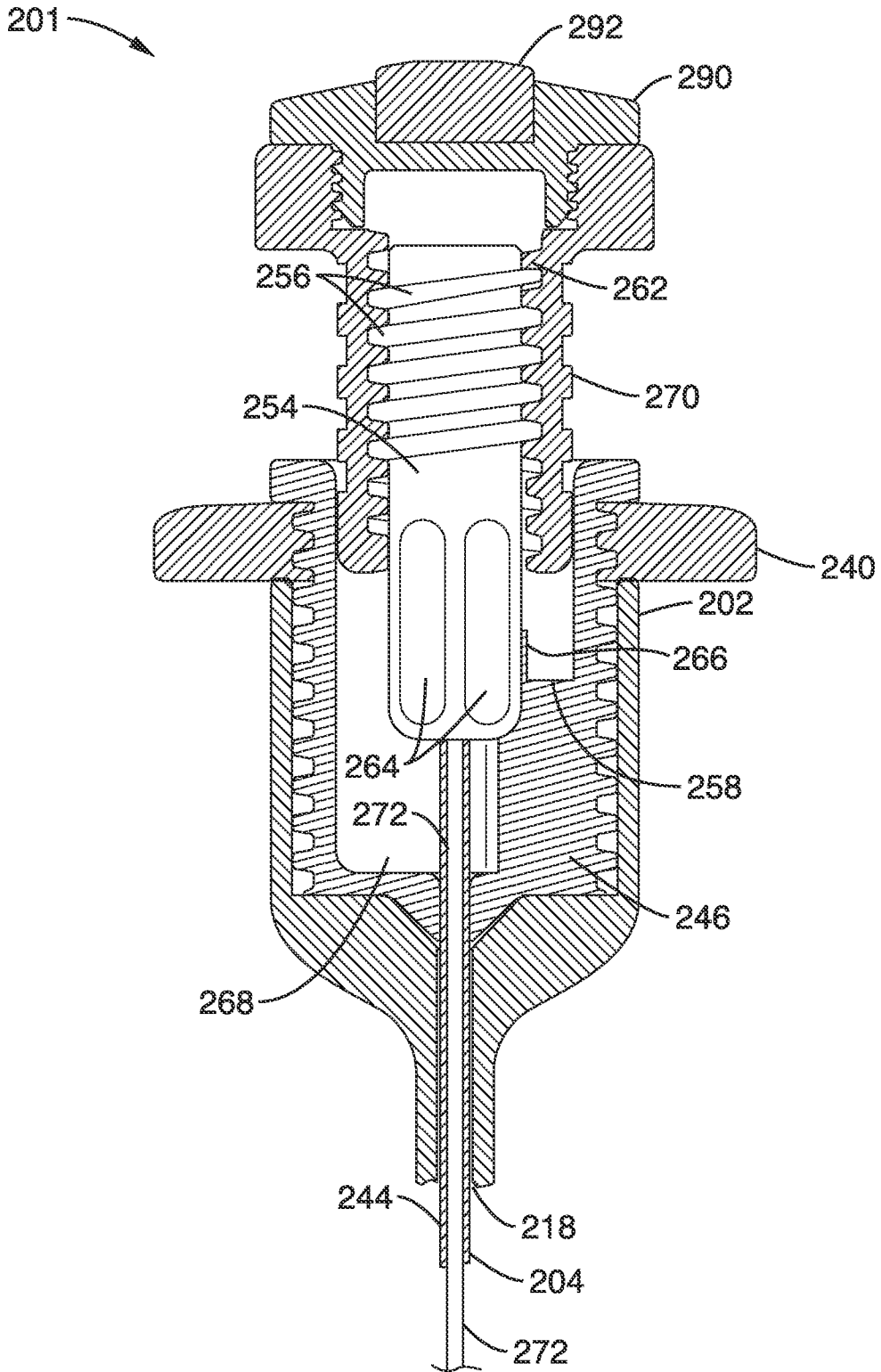

FIG. 15



201 →

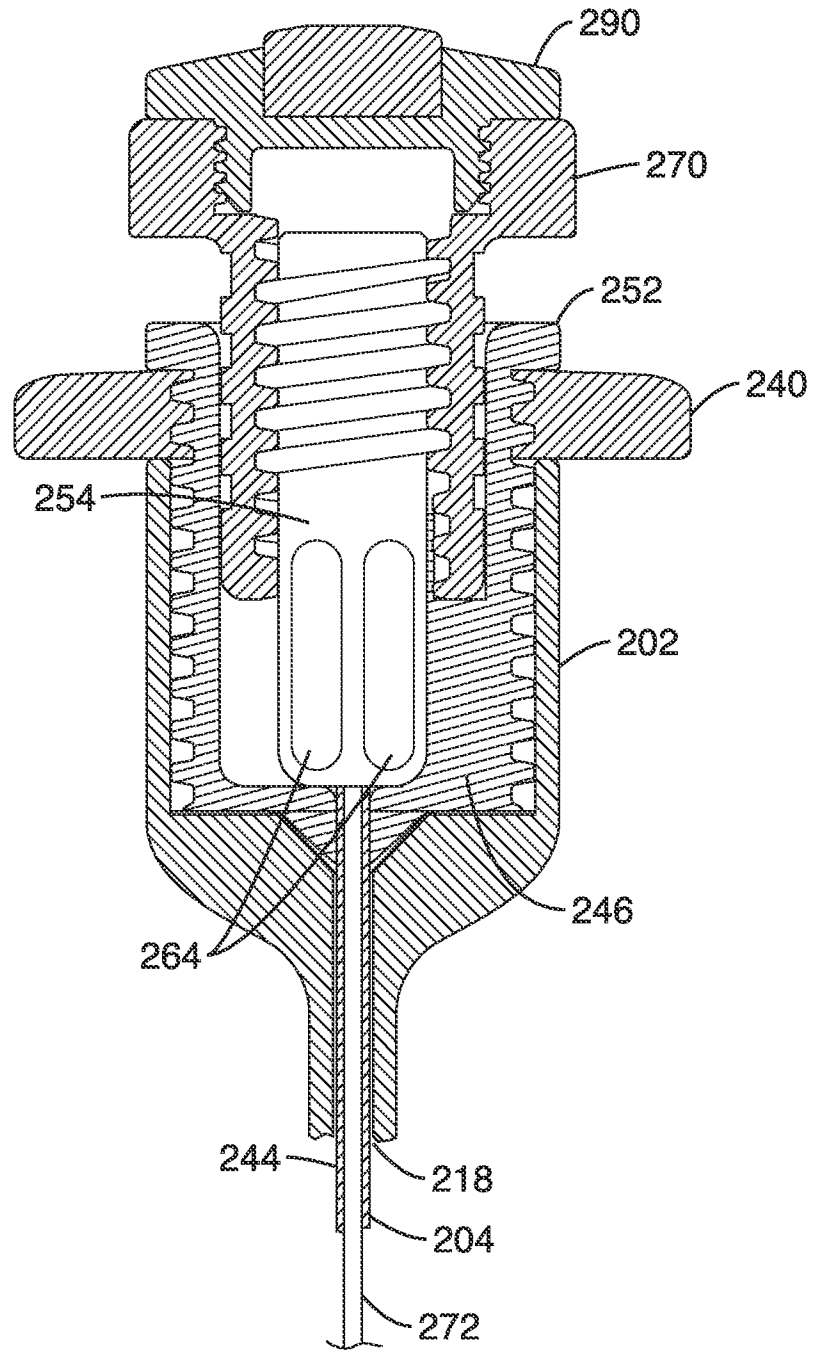

FIG. 16



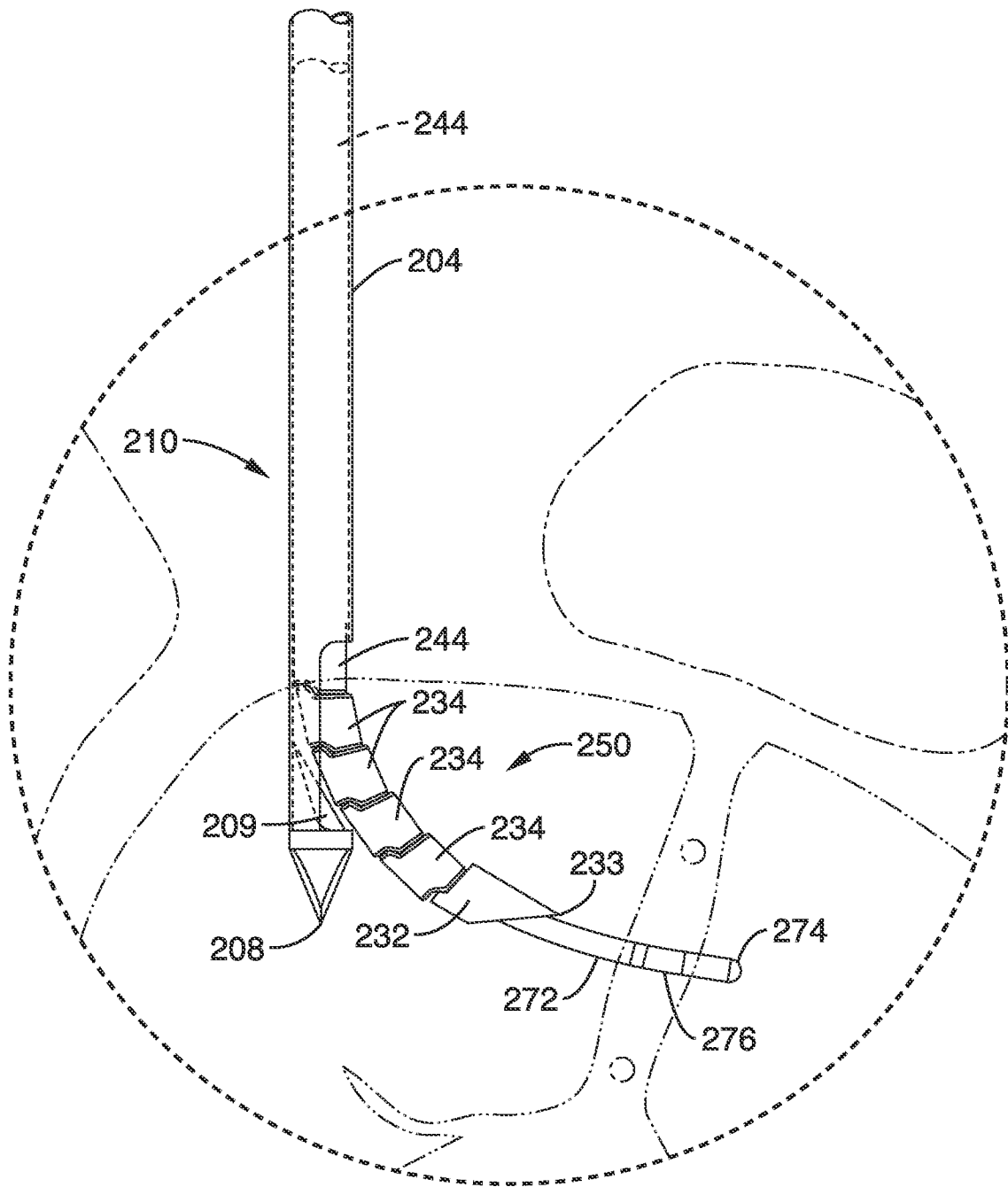

FIG. 17



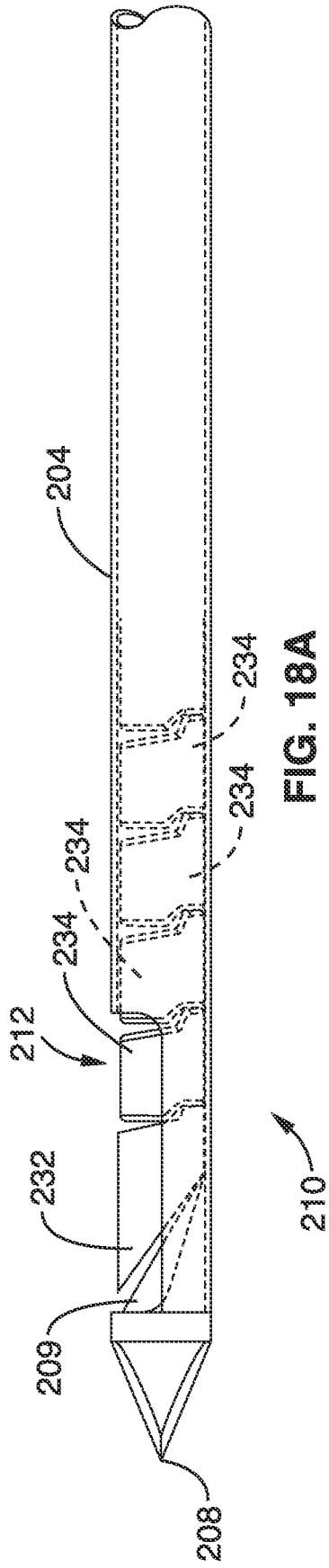

FIG. 18A

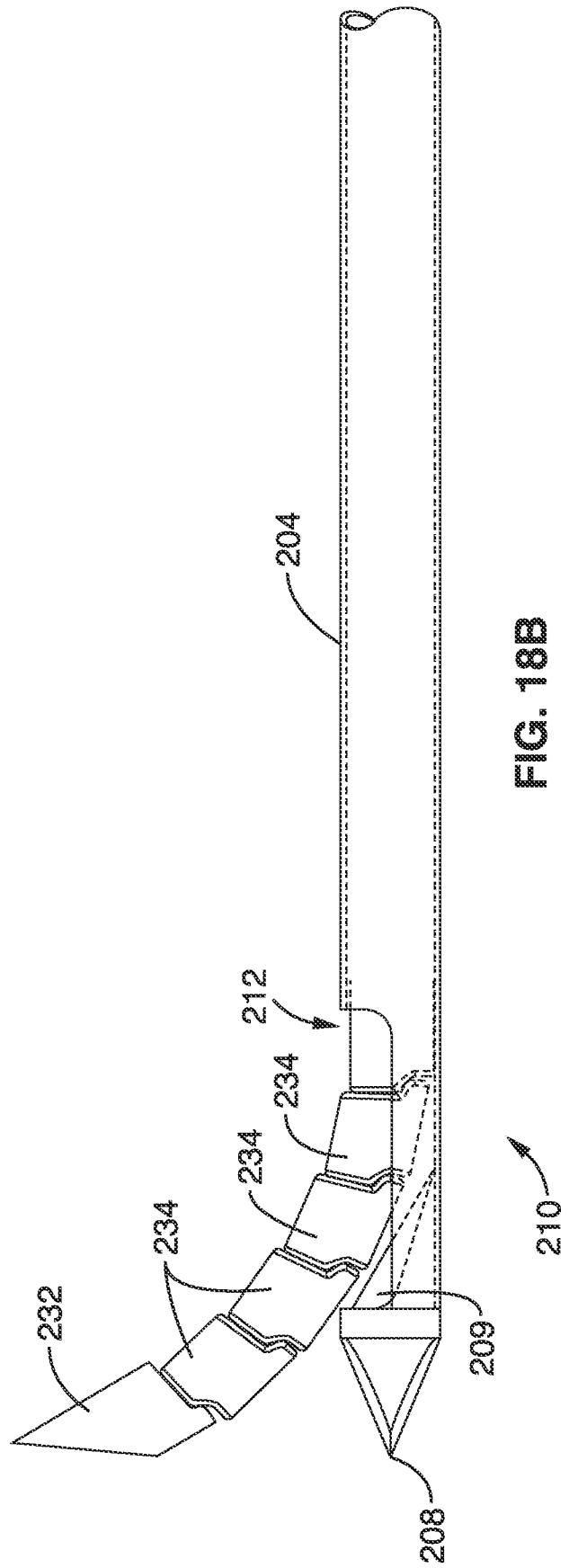

FIG. 18B



