

(19) World Intellectual Property Organization  
International Bureau



(43) International Publication Date  
30 May 2003 (30.05.2003)

PCT

(10) International Publication Number  
WO 03/043539 A1

(51) International Patent Classification<sup>7</sup>: A61F 2/06

(21) International Application Number: PCT/US02/30695

(22) International Filing Date:  
26 September 2002 (26.09.2002)

(25) Filing Language: English

(26) Publication Language: English

(30) Priority Data:  
09/978,988 16 October 2001 (16.10.2001) US

(71) Applicant: SCIMED LIFE SYSTEMS, INC. [US/US];  
One Scimed Place, Maple Grove, MN 55311-1566 (US).

(81) Designated States (*national*): AE, AG, AL, AM, AT, AU, AZ, BA, BB, BG, BR, BY, BZ, CA, CH, CN, CO, CR, CU, CZ, DE, DK, DM, DZ, EC, EE, ES, FI, GB, GD, GE, GH, GM, HR, HU, ID, IL, IN, IS, JP, KE, KG, KP, KR, KZ, LC, LK, LR, LS, LT, LU, LV, MA, MD, MG, MK, MN, MW, MX, MZ, NO, NZ, OM, PH, PL, PT, RO, RU, SD, SE, SG, SI, SK, SL, TJ, TM, TN, TR, TT, TZ, UA, UG, UZ, VC, VN, YU, ZA, ZM, ZW.

(84) Designated States (*regional*): ARIPO patent (GH, GM, KE, LS, MW, MZ, SD, SL, SZ, TZ, UG, ZM, ZW), Eurasian patent (AM, AZ, BY, KG, KZ, MD, RU, TJ, TM), European patent (AT, BE, BG, CH, CY, CZ, DE, DK, EE, ES, FI, FR, GB, GR, IE, IT, LU, MC, NL, PT, SE, SK, TR), OAPI patent (BF, BJ, CF, CG, CI, CM, GA, GN, GQ, GW, ML, MR, NE, SN, TD, TG).

(72) Inventor: SHERRY, John, E.; 130 Birds Hill Avenue, Needham, MA 02492 (US).

Published:  
— with international search report

(74) Agents: BUDZYN, Ludomir, A. et al.; Hoffmann & Baron, LLP, 6900 Jericho Turnpike, Syosset, NY 11791 (US).

For two-letter codes and other abbreviations, refer to the "Guidance Notes on Codes and Abbreviations" appearing at the beginning of each regular issue of the PCT Gazette.

(54) Title: TUBULAR PROSTHESIS FOR EXTERNAL AGENT DELIVERY

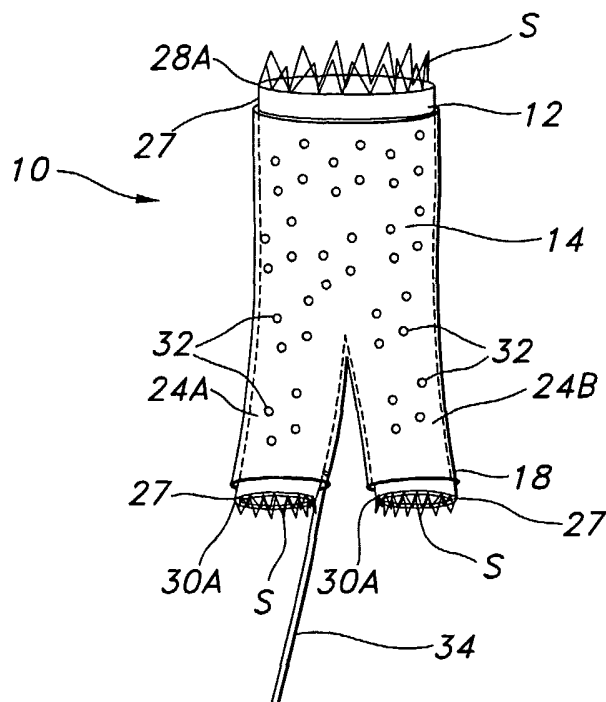

(57) Abstract: A tubular prosthesis, which may be an endovascular prosthesis, is provided which includes a tubular member (12, 12A) (stent or stent/graft combination) and an outer covering (14) having portions sealed to the tubular member. The tubular member is impervious to a pre-determined fluid, particularly an occluding fluid, while the outer cover is pervious to the pre-determined fluid. In one aspect of the present invention, the implantation of the prosthesis allows for occluding fluid to weep from the prosthesis and into a sac of an aneurysm to cause occlusion thereof without introducing the occluding fluid into the blood stream. In this manner, a Type II failure of the prosthesis may be avoided. In other aspects of the invention, therapeutic agents may be delivered and/or a seal may be formed about the prosthesis to prevent a Type I failure.

WO 03/043539 A1

**TUBULAR PROSTHESIS FOR EXTERNAL AGENT DELIVERY****FIELD OF THE INVENTION:**

[0001] This invention relates to tubular prostheses, including, but not limited to, endovascular grafts and stent/grafts, for maintaining patency of blood vessels and treating aortic artery aneurysms, and tubular conduits for maintaining patency in other bodily passageways.

**BACKGROUND OF THE PRIOR ART:**

[0002] It is known in the prior art to use endovascular prostheses to treat aortic artery aneurysms ("AAA"). Such treatment includes implanting a stent, or stent/graft, within the diseased vessel to by-pass the anomaly. An aneurysm is a sac formed by the dilation of the wall of the artery, which may be congenital, but usually is caused by disease and, occasionally, by trauma. With reference to Figure 1, sac 1 of aneurysm A is defined by dilated portions 2 of aortic artery AA. With the collection of blood and other embolic material in the sac 1, and being subjected to hemodynamic pressure, the aneurysm A may rupture, if untreated, causing internal bleeding.

[0003] Techniques had been developed in the prior art where diseased portions of a blood vessel, such as with an aneurysm, were ablated and replaced with a prosthetic member, such as that shown in U.S. Patent No. 4,938,740 to Melbin. This technique, however, required open surgery. As an improvement over this technique, endovascular emplacement techniques have been developed to implant grafts and stent/grafts into a vessel from a remote puncture site, thereby obviating the need for open surgery. For example, as shown in Figure

1, an endovascular prosthesis 3 (stent or stent/graft) is positioned to by-pass the aneurysm A with ends 4, 5 of the prosthesis being in contiguous contact with healthy portions of the aortic artery AA, the prosthesis 3 having been introduced endovascularly (e.g. with a catheter). Accordingly, if the aneurysm A was to rupture, blood flow through the aortic artery AA would be uninterrupted, and internal bleeding generally avoided.

**[0004]** Although considerable success has been enjoyed with stent and stent/graft performance, failures have been noted and predominantly classified in four classes: Types I-IV. Type I failures relate to leaks (referred to as endoleaks) between the vascular prosthesis and the vessel wall. For example, with reference to Figure 1, a Type I failure would be blood weeping about the end 4 of the prosthesis 3 into the sac 1.

**[0005]** A Type II failure involves blood flowing into the aneurysm sac through collateral arteries. Again, with reference to Figure 1, the sac 1 may be in fluid communication with blood vessels BV, other than the aortic artery AA. Typically, lumbar arteries are in fluid communication (directly or indirectly) with an aneurysm sac. Because blood flow out of the sac 1 is prevented, hemodynamic pressure away from the sac 1 is not present. However, because of hemodynamic pressure within blood vessels in communication with the sac 1, blood flow, nevertheless, is directed into the sac 1 (as shown by arrows). A technique has been developed in the prior art which calls for embolizing the blood vessels BV, such as with embolus coils, thereby isolating the sac 1 from collateral blood flow. However, an additional procedure would be required for embolization.

**[0006]** A Type III failure is a mechanical failure, wherein a hole may be ripped into the prosthesis (e.g., excessive wear at a metal/non-metal (fabric or polymer) interface) or

poor integrity exists at a connection, or connections, between modular components of a prosthesis, (e.g., extensions may be connected to the prosthesis to obtain improved securement in one or both of the iliac arteries.) For example, as shown in Figure 1, a hole 6 may be torn into the prosthesis 2, or poor sealing is obtained at the connection between the prosthesis 3 and an extension 7.

[0007] A Type IV failure relates to excessive prosthesis porosity, wherein blood seeps through the prosthesis regardless of the integrity of sealing and mechanical connections.

[0008] As can be readily appreciated, even with the successful implantation of an endovascular prosthesis, failures may occur thereafter. It has been found that Type II failures are most prevalent, and may effect up to 30% of all implanted prostheses. Accordingly, there is a clear need for an endovascular prosthesis which can reduce the likelihood, and ideally eliminate, Type II failures.

#### **SUMMARY OF THE INVENTION:**

[0009] To overcome deficiencies in the prior art, a tubular prosthesis is provided that includes a tubular member, which is impervious to a pre-determined fluid, and an outer covering, which is pervious to the pre-determined fluid. Accordingly, in one aspect of the invention, the prosthesis may be an endovascular prosthesis, and a fluid, which is effective for occluding the sac of an aneurysm, may be introduced by the prosthesis into a space between the tubular member and the outer covering. The fluid will transmit through the outer covering and weep into the sac to cause at least partial occlusion thereof without the occluding fluid being introduced into the blood stream. In this manner, collateral blood flow may be prevented from flowing into the aneurysm sac and collecting therein.

[0010] A fluid conduit, preferably a microcatheter, is connected to the endovascular prosthesis so as to be in fluid communication with the space defined between the tubular member and the outer covering. It is preferred that the fluid conduit be connected to the prosthesis prior to introduction into the body, with such connection continuing through deployment of the prosthesis and engagement with the vessel. Prior to withdrawal of the deployment device used to implant the prosthesis (e.g. an introducer catheter), occluding fluid is injected through the fluid conduit and between the tubular member and the outer cover with an effective amount of fluid being introduced to achieve at least partial occlusion of the aneurysm sac. With the outer cover being pervious to the fluid, the fluid transmits therethrough. Upon the effective dose having been injected into the space, the fluid conduit is caused to detach from the prosthesis, and withdrawn with any deployment device, such as a guidewire.

[0011] The tubular member may be of any endovascular prosthetic construction known in the prior art, including graft and stent/graft configurations (including single layer and multi-layer grafts and stent/grafts). The tubular member may be a textile graft, a polymeric graft, or a combination thereof. In addition, the tubular member may have a stent reinforcement (single stent or multiple stents), such stent being self-expanding or expandable by a distensible member, such as a balloon.

[0012] The outer covering may be formed of a textile, a polymeric film, or a combination thereof. In addition, the outer covering may be made pervious to the occluding fluid through inherent porosity of the constituent material of the outer covering (e.g., porosity of expanded polytetrafluoroethylene (ePTFE)), and/or, more preferably, through cut apertures physically defined in the outer covering. To attempt to achieve even distribution of the

occluding fluid, it is desired to make the outer covering increasingly pervious to the fluid at locations further from the fluid conduit.

[0013] The occluding fluid is preferably a liquid embolic, which may be an alginate, an hyleronic acid, and/or a cyanoacrylate, or an admixture thereof. Alternatively, a sclerosing agent may be used, as well as cross-linking polymers (polyurethanes, silicones), thrombin, and autologous clot(s). The occluding fluid may be in a liquid state or a gel, and may be formed with solids in a suspension of either state (liquid or gel).

[0014] In another aspect of the invention, therapeutic agents, with or without the occluding fluid, may be transmitted via the subject invention.

[0015] The tubular prosthesis may be used as an endovascular prosthesis, as well as, in other applications to maintain patency of a bodily passageway, such as the esophagus, trachea, colon, biliary tract, urinary tract, prostate, and brain.

[0016] These and other features of the invention would be better understood through a study of the following detailed description and accompanying drawings.

#### **BRIEF DESCRIPTION OF DRAWINGS**

[0017] Figure 1 is a schematic of an aortic artery aneurysm with an endovascular prosthesis by-passing thereby;

[0018] Figure 2 shows a first embodiment of a tubular prosthesis of the subject invention;

[0019] Figure 3 shows a tubular member for use with the first embodiment of the subject invention;

[0020] Figure 4 shows a second embodiment of a tubular prosthesis of the subject invention;

[0021] Figure 5 shows a bifurcated Y-shaped tubular member for use with the second embodiment of the subject invention; and

[0022] Figures 6A and 6B are schematics depicting the connections of a fluid conduit to the prosthesis.

#### **DETAILED DESCRIPTION OF THE INVENTION**

[0023] With reference to Figures 2 and 4, first and second embodiments of a prosthesis 10 are respectively depicted therein. Reference will be made herein to the prosthesis being endovascular, although as pointed out above, the prosthesis may be used in other applications. In each embodiment, the endovascular prosthesis 10 includes a tubular member 12, 12a and an outer covering 14. The tubular member 12, 12a is impervious to the transmission therethrough of a pre-determined fluid, particularly an occluding fluid, while the outer covering 14 is pervious to the transmission therethrough of the pre-determined fluid. Accordingly, the prosthesis 10 can be utilized to at least partially occlude the sac of an aneurysm, as described below. The endovascular prosthesis 10 may take any shape or form as required, although commonly, the prosthesis 10 will have a cylindrical shape (as shown in Figure 2), or a bifurcated Y-shape (as shown in Figure 4). Although only these two shapes are shown, other shapes are possible.

[0024] The tubular member 12, 12a may be of any endovascular prosthetic construction known in the prior art, including graft and stent/graft configurations. With reference to Figure 3, in the first embodiment, the tubular member 12 has a cylindrical shape with a tubular wall 16 having an outer surface 18 and an inner surface 20 defining a single lumen 22. The tubular member 12 need not be formed as a right cylinder, and may be irregularly formed (e.g. bent; eccentric). In a second embodiment, as shown in Figure 5, the tubular member 12a has a bifurcated Y-shape with a first tubular portion 16a, defining a lumen 22a, from which extend branches 24a, 24b, each defining a lumen 26 in fluid communication with the lumen 22a. As is readily apparent, the tubular member 12, 12a defines the general shape of the endovascular prosthesis 10, and thus, the tubular member 12, 12a is formed to any desired shape of the endovascular prosthesis 10.

[0025] The tubular member 12, 12a may be a textile graft, a polymeric graft, or a combination thereof (including single layer and multi-layer configurations). In addition, the tubular member 12, 12a may have a stent reinforcement, such stent being self-expanding or expandable by a distensible member, such as a balloon (stents S are shown in Figure 5) (a single stent or multiple stents may be used). Graft and stent/graft designs are well known in the art, and any design compatible with the invention may be used. The tubular member 12, 12a is shown in each embodiment as a unitary member, regardless of shape. As an alternative, the tubular member 12, 12a may be formed from modular components and/or have the shape as shown, but connected to extensions as known in the prior art (e.g. the extension 7 shown in Figure 1).

[0026] The outer covering 14 is disposed on, and preferably sealed to, portions of the outer surface of the tubular member 12, 12a. In a preferred embodiment, as shown in Figures



2 and 4, the outer covering 14 is generally coextensive with the tubular member 12, 12a. The outer covering 27 is sealed to the tubular member 14 using any technique known to those skilled in the art, including, but not limited to, fusing and bonding. Sealed portions 27 of the outer covering 14 are preferably spaced-apart so that unsealed portions of the outer covering 14 are bounded by the sealed portions 27. In this manner, entrapped space between the tubular member 12, 12a and the outer covering 14 which is at least partially bounded by the sealed portions 27 of the outer covering 14 defines a pocket 15 for receiving occluding fluid. Optionally, the outer covering 14 can be sealed at multiple locations to define multiple pockets 15. Because of the impervious nature of the tubular member 12, 12a and the sealed portions 27, the fluid can only escape from the pocket 15 via transmission through the outer covering 14. As shown in Figure 2, it is preferred to seal the outer covering 14 at portions in proximity to the ends 28 and 30 of the tubular member 12. With respect to the tubular member 12a, as shown in Figure 4, it is preferred that the outer covering 14 have sealed portions 27 in proximity to all ends 28a and 30a. Accordingly, the pocket 15 is generally coextensive with the tubular member 12, 12a.

[0027] As a variation, the outer covering 14 may be formed as a patch which covers only a portion of the tubular member 12, 12a, as shown in dashed lines in Figure 2.

Although not shown, the outer covering 14 may form an annular band about the tubular member 12, 12a. Furthermore, multiple outer coverings 14 may be used as patches to form a discontinuous or regular pattern.

[0028] The outer covering 14 may be formed of a textile, a polymeric film, or a combination thereof. The critical aspect of the outer covering 14 is for it to be pervious to the occluding fluid. The outer covering 14 may be made pervious through inherent porosity of

the constituent material of the outer covering, for example due to the porosity of expanded polytetrafluoroethylene (ePTFE). In addition, in a preferred manner of achieving the pervious nature of the outer covering 14, cut apertures 32 may be physically defined in the outer covering 14, as shown in Figure 4. It is also possible to combine these two approaches.

[0029] In a preferred embodiment, a fluid conduit 34, preferably a microcatheter, is connected to the endovascular prosthesis 10 so as to convey the occluding fluid thereto. With reference to Figures 6a and 6b, the fluid conduit 34 may be in direct fluid communication with the pocket 15, with an end 36 of the fluid conduit 34 being located therein. As can be appreciated, to achieve this result, the fluid conduit 34 must breach the sealed portions 27. This can be readily done during manufacturing by causing the sealed portions 27 to be formed about the fluid conduit 34. However, upon removal of the fluid conduit 34, an open passage will be defined through the sealed portions 27. Thus, it is preferred to only use the technique where inherent viscosity of the occluding fluid will prevent leakage of the occluding fluid through the open passage.

[0030] As a preferred alternative, a valve 38 (preferably one-way) is disposed in communication with the pocket 15, so that the fluid conduit 34 is in indirect communication with the pocket 15 via the valve 38. The construction of the valve 38 and the fluid conduit 34 may be the same as that used with silicone balloon distension, (e.g., the system sold under the trademark "APOLLO" by Target Therapeutics of Fremont, California).

[0031] In a preferred embodiment, the fluid conduit 34 is connected to the endovascular prosthesis 10 prior to insertion into the human body. After deployment of the endovascular prosthesis 10, using any technique and device known, the fluid conduit 34

preferably remains connected to the prosthesis 10. It is envisioned that a Strecker pull-string type deployment device or a pull-back sheath deployment device would operate well with the subject invention. An effective amount of occluding fluid is conveyed through the fluid conduit 34 into the pocket 15 to at least partially occlude the sac of the aneurysm being treated. With the effective dose having been conveyed, the fluid conduit 34 is caused to be detached, preferably with a sufficiently strong pull of the fluid conduit 34. With the aforementioned prior art silicone balloon distension systems, minimum threshold forces have been developed to achieve such detachment and it is contemplated herein to use similar methodology to require minimum threshold forces for detachment. Once detached, the fluid conduit 34 is removed with any other deployment devices, such as an introducer catheter.

**[0032]** The occluding fluid is preferably a liquid embolic, which may be an alginate, an hyleronic acid, and/or a cyanoacrylate, or an admixture thereof. Alternatively, a sclerosing agent may be used, as well as cross-linking polymers (polyurethanes, silicones), thrombin and autologous clot(s). The occluding fluid may be in a liquid state or gel, and may be formed with solids in a suspension of either state (liquid or gel).

**[0033]** With the occluding fluid being disposed within the pocket 15, the fluid may transmit through the outer covering 14 to at least partially occlude the sac of the aneurysm being treated without the fluid being introduced into the blood stream.

**[0034]** In another aspect of the invention, therapeutic agents, with or without the occluding fluid, may be transmitted via the subject invention in the same manner described with respect to the occluding fluid, including: anti-thrombogenic agents (such as heparin, heparin derivatives, urokinase, and PPACK (dextrophenylalanine proline arginine

chloromethylketone); anti-proliferative agents (such as enoxaprin, angiopeptin, or monoclonal antibodies capable of blocking smooth muscle cell proliferation, hirudin, and acetylsalicylic acid); anti-inflammatory agents (such as dexamethasone, prednisolone, corticosterone, budesonide, estrogen, sulfasalazine, and mesalamine); antineoplastic/antiproliferative/anti-miotoxic agents (such as paclitaxel, 5-fluorouracil, cisplatin, vinblastine, vincristine, epothilones, endostatin, angiostatin and thymidine kinase inhibitors); anesthetic agents (such as lidocaine, bupivacaine, and ropivacaine); anti-coagulants (such as D-Phe-Pro-Arg chloromethyl keton, an RGD peptide-containing compound, heparin, antithrombin compounds, platelet receptor antagonists, anti-thrombin antibodies, anti-platelet receptor antibodies, aspirin, prostaglandin inhibitors, platelet inhibitors and tick antiplatelet peptides); vascular cell growth promoters (such as growth factor inhibitors, growth factor receptor antagonists, transcriptional activators, and translational promoters); vascular cell growth inhibitors (such as growth factor inhibitors, growth factor receptor antagonists, transcriptional repressors, translational repressors, replication inhibitors, inhibitory antibodies, antibodies directed against growth factors, bifunctional molecules consisting of a growth factor and a cytotoxin, bifunctional molecules consisting of an antibody and a cytotoxin); cholesterol-lowering agents; vasodilating agents; and agents which interfere with endogenous vasoactive mechanisms.

**[0035]** In a further aspect of the subject invention, the occluding fluid may be introduced via the endovascular prosthesis 10 between the blood vessel wall and the endovascular prosthesis 10 so as to at least partially seal against endoleaks about the prosthesis 10 (i.e., Type I failure). (With other applications of the subject invention, the occluding fluid is disposed between the wall of the bodily passageway and the prosthesis 10.) The occluding fluid may create a blood-vessel seal (in whole or in part) with or without

occluding the sac of the aneurysm. Preferably, a ring-shaped pocket 15 may be provided in proximity to an end of endovascular prosthesis 10 through which the occluding fluid may be delivered to form the seal; as such, an annular seal may be desirably defined about the prosthesis 10 in proximity to an end so as to restrict endoleaks. The ability to seal against endoleaks is particularly desirable where a blood vessel has an irregularly formed blood vessel.

**[0036]** In a further enhancement of the invention, it is preferred that the outer covering 14 be increasingly pervious to the occluding fluid and/or therapeutic agents at further distances from the fluid conduit 34. For example, with reference to Figure 4, the cut apertures 32 are formed increasingly larger further from the fluid conduit 35 (i.e., as approaching the end 28A) and/or an increasingly greater number of cut apertures 32 is provided further from the fluid conduit 34 (i.e., the density of cut apertures 32 increases with distance from the fluid conduit 34) to provide less resistance to the distribution of the occluding fluid and/or therapeutics being conveyed via the fluid conduit 34. Likewise, the cut apertures 32 are formed increasingly larger and/or greater in number as located further down the branch portion 24b, to which the fluid conduit 34 is not attached. As an alternative, or as an additional option, the porosity of the constituent material may be gradually increased at further locations from the source of the occluding fluid and/or therapeutic agents to also provide less fluid resistance.

**[0037]** Various changes and modifications can be made to the present invention. It is intended that all such changes and modifications come within the scope of the invention as set forth in the following claims.

**WHAT IS CLAIMED IS:**

1. A tubular prosthesis comprising:  
a tubular member having a wall with an inner surface and an outer surface, said wall being impervious to transmission therethrough of a pre-determined fluid; and  
an outer covering having portions sealed to said outer surface of said tubular member, said outer cover being pervious to transmission therethrough of said pre-determined fluid.
2. As prosthesis as in claim 1, wherein said tubular member is formed of a polymeric material.
3. A prosthesis as in claim 1, wherein said tubular member is formed of a textile material.
4. A prosthesis as in claim 1, wherein said tubular member includes a polymeric material and a textile material.
5. A prosthesis as in claim 1, wherein said outer covering is generally coextensive with said tubular member.
6. A prosthesis as in claim 1, wherein said tubular member has a first opening, said outer covering being sealed to said tubular member in proximity to said first opening.
7. A prosthesis as in claim 1, wherein said tubular member is cylindrical.

8. A prosthesis as in claim 1, wherein said tubular member is generally Y-shaped with a single lumen being in fluid communication with two minor lumens.
9. A prosthesis as in claim 1, wherein said outer covering is a porous material.
10. A prosthesis as in claim 1, wherein cut apertures are formed in said outer covering.
11. A prosthesis as in claim 10, wherein said cut apertures are each generally equal in size.
12. A prosthesis as in claim 10, wherein said cut apertures are of various sizes.
13. A prosthesis is as in claim 10, wherein said cut apertures are unevenly dispersed.
14. A prosthesis as in claim 1, further comprising a fluid conduit having an end communicating with space defined between said tubular member and said outer cover, said fluid conduit formed to convey said pre-determined fluid to said space.
15. A prosthesis as in claim 14, wherein said end of said fluid conduit directly communicates with said space with said end being located in said space.
16. A prosthesis as in claim 14, wherein said end indirectly communicates with said space via a valve.

17. A prosthesis as in claim 14, wherein said outer covering is increasingly pervious to transmission therethrough of said pre-determined fluid at locations increasingly further from said end of said fluid conduit.
18. A prosthesis as in claim 17, wherein cut apertures are formed in said outer covering, said cut apertures being increasingly larger as located increasingly further located from said end of said fluid conduit.
19. A prosthesis as in claim 17, wherein cut apertures are formed in said outer covering, the density of said cut apertures increasing with distance from said end of said fluid conduit.
20. A prosthesis as in claim 17, wherein said outer covering is increasingly porous at locations increasingly further from said end of said fluid conduit.
21. A prosthesis as in claim 1, wherein said pre-determined fluid is an occluding fluid.
22. A prosthesis as in claim 21, wherein said occluding fluid is an embolic liquid selected from the group consisting of alginates, hyleronic acid, cyanoacrylates, and admixtures thereof.
23. A prosthesis as in claim 21, wherein said occluding fluid is selected from the group consisting of sclerosing agents, polyurethanes, silicones, and admixtures thereof.
24. A prosthesis as in claim 21, wherein said occluding fluid includes thrombin.



25. A prosthesis as in claim 21, wherein said occluding fluid includes an autologous clot.
26. A prosthesis as in claim 1, wherein said tubular member is a graft.
27. A prosthesis as in claim 1, wherein said tubular member is a stent/graft combination.
28. A prosthesis as in claim 27, wherein said stent is expandable.
29. A prosthesis as in claim 28, wherein said stent is self-expanding.
30. A prosthesis as in claim 1, wherein said sealed portions of said outer covering at least partially bound a pocket for receiving said pre-determined fluid.
31. A prosthesis as in claim 30, wherein said pocket is generally coextensive with said tubular member.
32. A prosthesis as in claim 1, wherein said pre-determined fluid is a therapeutic agent.
33. A prosthesis as in claim 1, wherein the prosthesis is an endovascular prosthesis.

34. A method of occluding a sac of an aneurysm, the method comprising the steps of:  
implanting endovascularly an endovascular prosthesis which by-passes the aneurysm, said endovascular prosthesis including a tubular member having a wall, said wall being impervious to transmission therethrough of an occluding fluid, and an outer covering having portions sealed to said tubular member, said outer covering being pervious to transmission therethrough of said occluding fluid; and  
conveying a dose of occluding fluid into a pocket at least partially defined between said tubular member and said outer covering, said dose being an effective amount to at least partially occlude the sac of the aneurysm, whereby said occluding fluid transmits through said outer covering to at least partially occlude the sac of the aneurysm.
35. A method as in claim 34 further comprising the step of placing a fluid conduit into fluid communication with said pocket.
36. A method as in claim 35, wherein the step of conveying a dose of occluding fluid includes conveying said occluding fluid via said fluid conduit.
37. A method as in claim 35, wherein the step of placing a fluid conduit is performed before the step of implanting endovascularly.
38. A method as in claim 37, further comprising the step of detaching said fluid conduit from said endovascular prosthesis after the step of conveying a dose of occluding fluid.

39. A method as in claim 34, wherein said occluding fluid is an embolic liquid selected from the group consisting of alginates, hyleronic acid, cyanoacrylates, and admixtures thereof.
40. A method as in claim 34, wherein said occluding fluid is selected from the group consisting of sclerosing agents, polyurethanes, silicones, and admixtures thereof.
41. A method as in claim 34, wherein said occluding fluid includes thrombin.
42. A method as in claim 34, wherein said occluding fluid includes an autologous clot.
43. A method of forming an endovascular prosthesis, the method comprising the steps of:  
providing a tubular member which includes a wall, said wall being impervious to transmission therethrough of a pre-determined fluid; and  
sealing portions of an outer covering to said tubular member, said outer covering being pervious to transmission therethrough of said pre-determined fluid.
44. A method as in claim 43, further comprising the step of placing a fluid conduit in direct fluid communication with a pocket at least partially defined between said tubular member and said outer covering.
45. A method as in claim 43, further comprising the step of placing a fluid conduit in indirect fluid communication with a pocket at least partially defined between said tubular member and said outer covering.

46. A method as in claim 45, wherein the step of placing a fluid conduit includes mounting a valve in fluid communication with said pocket, and connecting said fluid conduit to said valve.
47. A method as in claim 43, further comprising the step of making said outer covering be pervious to transmission therethrough of said pre-determined fluid.
48. A method as in claim 47, wherein the step of making includes cutting apertures in said outer covering.
49. A method as in claim 47, wherein the step of making includes forming said outer covering with porosity.
50. A method as in claim 43, wherein the step of sealing includes fusing portions of said outer covering to said tubular member.
51. A method as in claim 43, wherein the step of sealing includes bonding portions of said outer covering to said tubular member.
52. A method of administering a therapeutic agent, the method comprising the steps of:  
implanting a tubular prosthesis, said prosthesis including a tubular member having a wall, said wall being impervious to transmission therethrough of a pre-determined therapeutic agent, and an outer covering having portions sealed to said tubular member, said outer covering being pervious to transmission therethrough of said pre-determined therapeutic agent; and

conveying a dose of said pre-determined therapeutic agent into a pocket at least partially defined between said tubular member and said outer covering.

53. A method as in claim 52, further comprising the step of placing a fluid conduit into fluid communication with said pocket.

54. A method as in claim 53, wherein the step of conveying a dose of pre-determined therapeutic agent includes conveying said pre-determined therapeutic agent via said fluid conduit.

55. A method as in claim 53, wherein the step of placing a fluid conduit is performed before the step of implanting endovascularly.

56. A method as in claim 55, further comprising the step of detaching said fluid conduit from said prosthesis after the step of conveying a dose of pre-determined therapeutic agent.

57. A method of at least partially forming a seal between a tubular prosthesis and a bodily passageway, the method comprising the steps of:

implanting a tubular prosthesis into a bodily passageway, said prosthesis including a tubular member having a wall, said wall being impervious to transmission therethrough of an occluding fluid, and an outer covering having portions sealed to said tubular member, said outer covering being pervious to transmission therethrough of said occluding fluid; and

conveying a dose of occluding fluid into a pocket at least partially defined between said tubular member and said outer covering, said dose being an effective amount to at least

partially occlude an area about said tubular member so as to at least partially form a seal between said prosthesis and portions of the bodily passageway.

58. A method as in claim 57, wherein said occluding fluid is an embolic liquid selected from the group consisting of algenates, hyleronic acid, cyanoacrylates, and admixtures thereof.

59. A method as in claim 57, wherein said occluding fluid is selected from the group consisting of sclerosing agents, polyurethanes, silicones, and admixtures thereof.

60. A method as in claim 57, wherein said occluding fluid includes thrombin.

61. A method as in claim 57, wherein said occluding fluid includes an autologous clot.

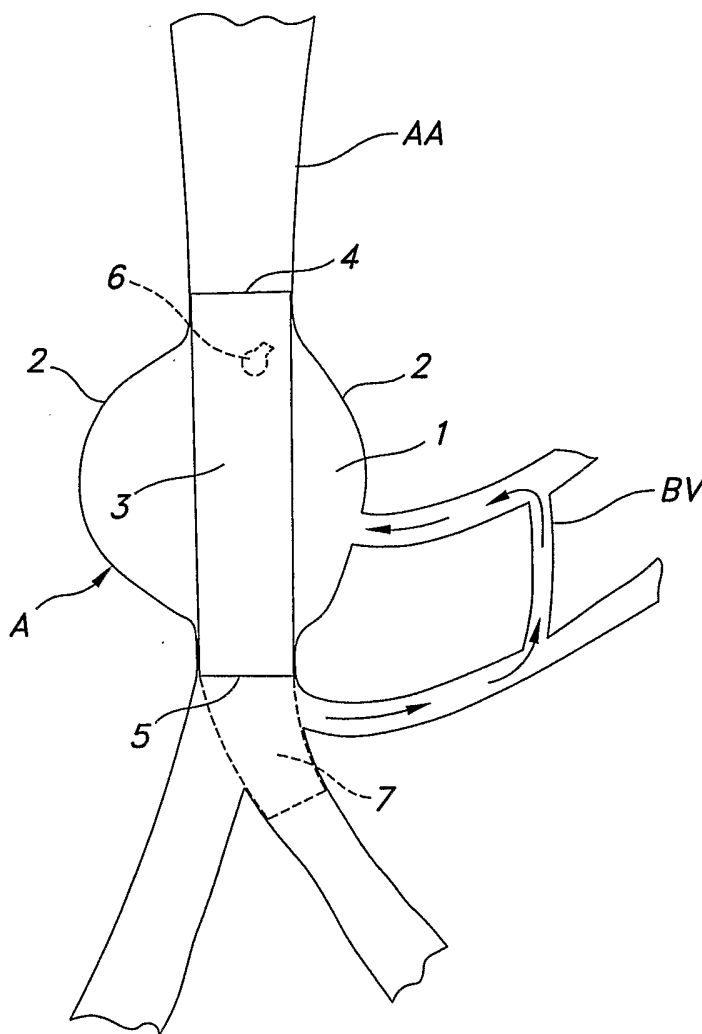

**FIG. 1**  
(PRIOR ART)

2/3

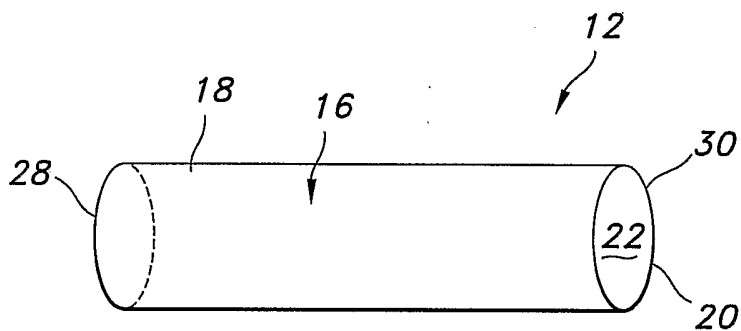

FIG. 3

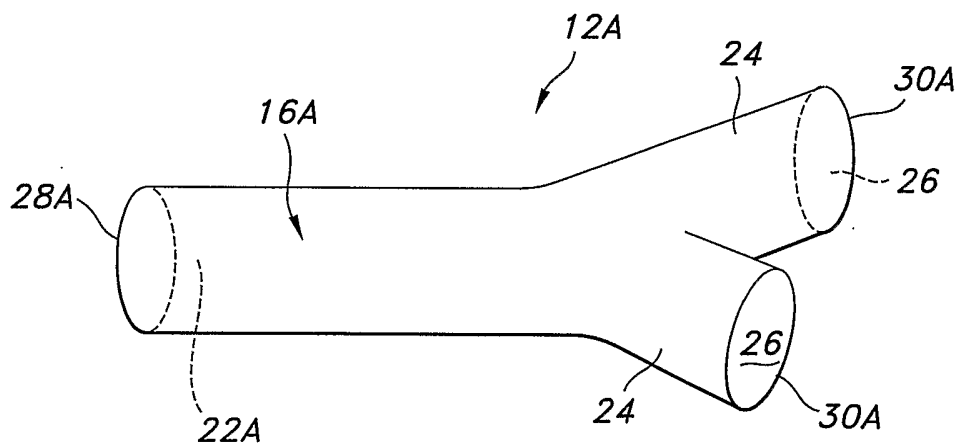

FIG. 5

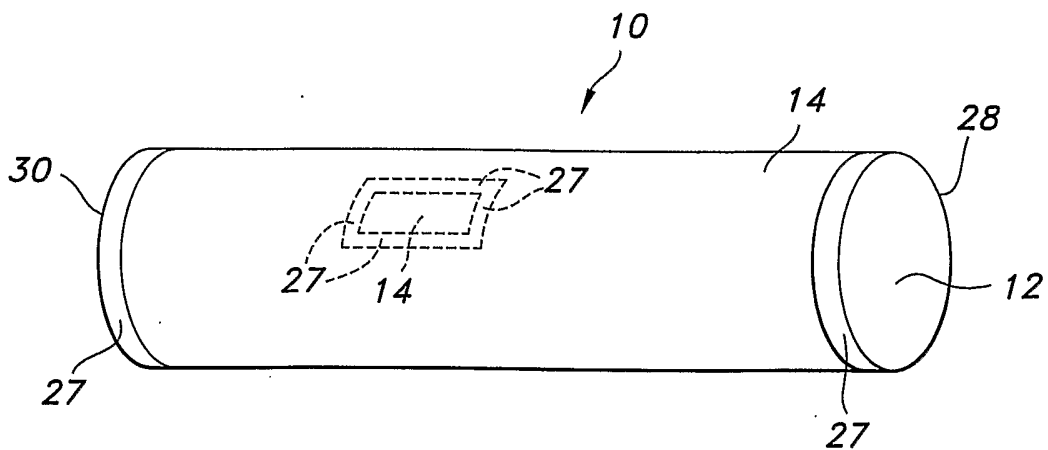

FIG. 2





3/3

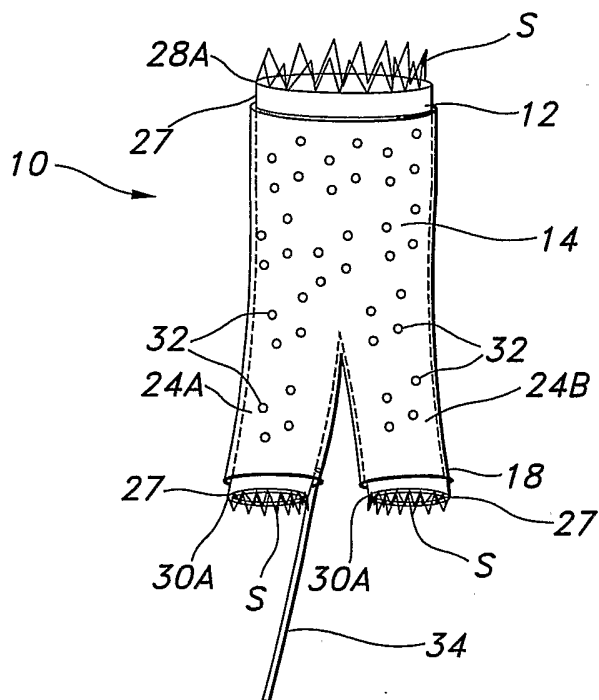

FIG. 4

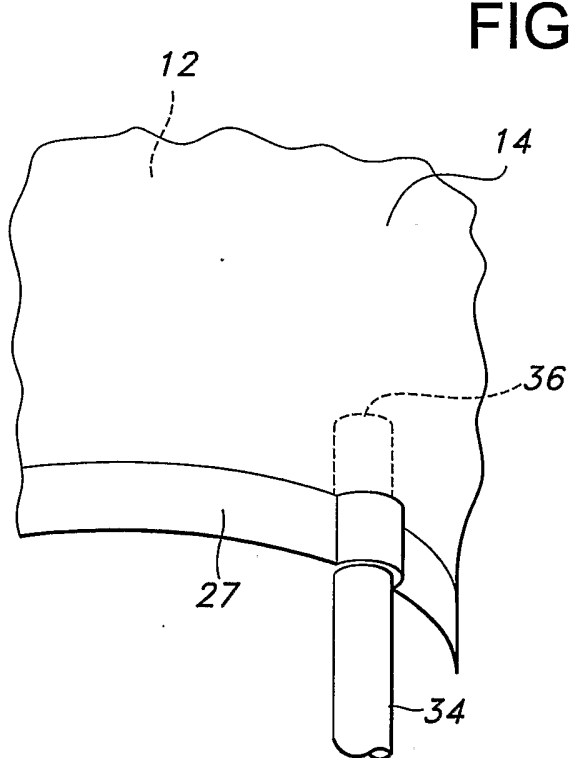

FIG. 6A

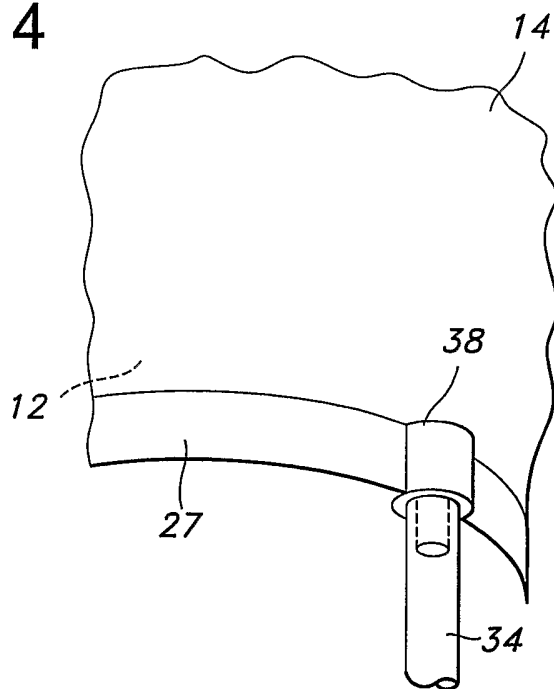

FIG. 6B

INTERNATIONAL SEARCH REPORT

In tional Application No  
PCT/US 02/30695

<b>A. CLASSIFICATION OF SUBJECT MATTER</b> IPC 7 A61F2/06		
According to International Patent Classification (IPC) or to both national classification and IPC		
<b>B. FIELDS SEARCHED</b>		
Minimum documentation searched (classification system followed by classification symbols) IPC 7 A61F A61B A61L		
Documentation searched other than minimum documentation to the extent that such documents are included in the fields searched		
Electronic data base consulted during the international search (name of data base and, where practical, search terms used) EPO-Internal		
<b>C. DOCUMENTS CONSIDERED TO BE RELEVANT</b>		
Category °	Citation of document, with indication, where appropriate, of the relevant passages	Relevant to claim No.
X  A	WO 98 11847 A (WHAYNE JAMES G ;FLEISCHMAN SID D (US); HOUSER RUSSELL A (US)) 26 March 1998 (1998-03-26)  page 15, line 1, paragraph 3 - line 4, paragraph 3 page 10, paragraph 3 page 15, line 1, paragraph 4 - line 3, paragraph 4 figures 16,23  --- -/--	1,2, 5-13, 27-33, 43,47-51 3,4,14, 21,26, 34,44, 45,52
<input checked="" type="checkbox"/> Further documents are listed in the continuation of box C.		
<input checked="" type="checkbox"/> Patent family members are listed in annex.		
° Special categories of cited documents :		
*A* document defining the general state of the art which is not considered to be of particular relevance *E* earlier document but published on or after the international filing date *L* document which may throw doubts on priority claim(s) or which is cited to establish the publication date of another citation or other special reason (as specified) *O* document referring to an oral disclosure, use, exhibition or other means *P* document published prior to the international filing date but later than the priority date claimed		
*T* later document published after the international filing date or priority date and not in conflict with the application but cited to understand the principle or theory underlying the invention *X* document of particular relevance; the claimed invention cannot be considered novel or cannot be considered to involve an inventive step when the document is taken alone *Y* document of particular relevance; the claimed invention cannot be considered to involve an inventive step when the document is combined with one or more other such documents, such combination being obvious to a person skilled in the art. *&* document member of the same patent family		
Date of the actual completion of the international search  13 January 2003		Date of mailing of the international search report  20/01/2003
Name and mailing address of the ISA European Patent Office, P.B. 5818 Patentlaan 2 NL - 2280 HV Rijswijk Tel. (+31-70) 340-2040, Tx. 31 651 epo nl, Fax: (+31-70) 340-3016		Authorized officer  Amaro, H

## INTERNATIONAL SEARCH REPORT

International Application No  
PCT/US 02/30695

## C.(Continuation) DOCUMENTS CONSIDERED TO BE RELEVANT

Category *	Citation of document, with indication, where appropriate, of the relevant passages	Relevant to claim No.
A	US 5 951 599 A (MCCRORY JENNIFER J) 14 September 1999 (1999-09-14)  figures 2B,3B-3D column 4, line 19 - line 33 column 5, line 36 - line 65 ---	1,2,5-7, 9-13,33, 43,47-49
A	US 6 096 070 A (BATES BRIAN L ET AL) 1 August 2000 (2000-08-01) column 7, line 29 - line 47 column 10, line 28 - line 34 column 10, line 65 -column 11, line 11 figures 1,2 ---	1,2,5,6
A	US 2001/027338 A1 (GREENBERG ROY K) 4 October 2001 (2001-10-04) page 3, paragraph 3 figure 6 -----	57

## INTERNATIONAL SEARCH REPORT

 International Application No  
 PCT/US 02/30695

Patent document cited in search report		Publication date	Patent family member(s)	Publication date
WO 9811847	A	26-03-1998	AU 4489197	A 14-04-1998
			EP 1011524	A1 28-06-2000
			WO 9811847	A1 26-03-1998
			US 6293955	B1 25-09-2001
			US 6149681	A 21-11-2000
US 5951599	A	14-09-1999	AU 8290498	A 08-02-1999
			EP 0994674	A1 26-04-2000
			JP 2001509412	T 24-07-2001
			WO 9902092	A1 21-01-1999
US 6096070	A	01-08-2000	US 5609629	A 11-03-1997
			AU 716005	B2 17-02-2000
			AU 5588896	A 19-12-1996
			CA 2178541	A1 08-12-1996
			WO 9817331	A1 30-04-1998
			US 5824049	A 20-10-1998
			US 5873904	A 23-02-1999
			DE 69623855	D1 31-10-2002
			DK 747069	T3 09-12-2002
			EP 0747069	A2 11-12-1996
			JP 9099056	A 15-04-1997
US 2001027338	A1	04-10-2001	AU 4539401	A 17-09-2001
			EP 1259192	A2 27-11-2002
			WO 0166038	A2 13-09-2001