



(11) **EP 2 050 684 A2**

(12) **EUROPEAN PATENT APPLICATION**

(43) Date of publication:
22.04.2009 Bulletin 2009/17

(51) Int Cl.:
B65D 33/25 (2006.01)

(21) Application number: **08105561.8**

(22) Date of filing: **13.10.2008**

(84) Designated Contracting States:
AT BE BG CH CY CZ DE DK EE ES FI FR GB GR HR HU IE IS IT LI LT LU LV MC MT NL NO PL PT RO SE SI SK TR
Designated Extension States:
AL BA MK RS

(71) Applicant: **Lock & Lock Co., Ltd.**
Asan, Chungnam (KR)

(72) Inventor: **Kim, Chang Ho**
Seoul (KR)

(30) Priority: **19.10.2007 KR 20070105598**

(74) Representative: **Capasso, Olga et al**
De Simone & Partners S.p.A.
Via Vincenzo Bellini, 20
00198 Roma (IT)

(54) **Slider end stop for reclosable plastic bag, and reclosable plastic bag having the same**

(57) The present invention provides a reclosable plastic bag (10) including: a first film (12) and a second film (14) of which both sides and lower sides adhere to each other and the combined upper side is open; a zipper (20) including a first zipper (20a) and a second zipper (20b) that are provided on the insides of the upper sides of the first film and second film and engaged with each other; a slider (30a) engaging the first zipper with the second zipper, sliding on the zipper; and end stops (40a, 40b) of which both ends are formed in flange shapes and that each have a through-hole at the center to prevent the slider from separating from the ends of the zipper by being fitted in insertion holes formed through the first film and the second film. Furthermore, the present invention relates to a slider end stop for a reclosable plastic bag.

[FIG. 1]

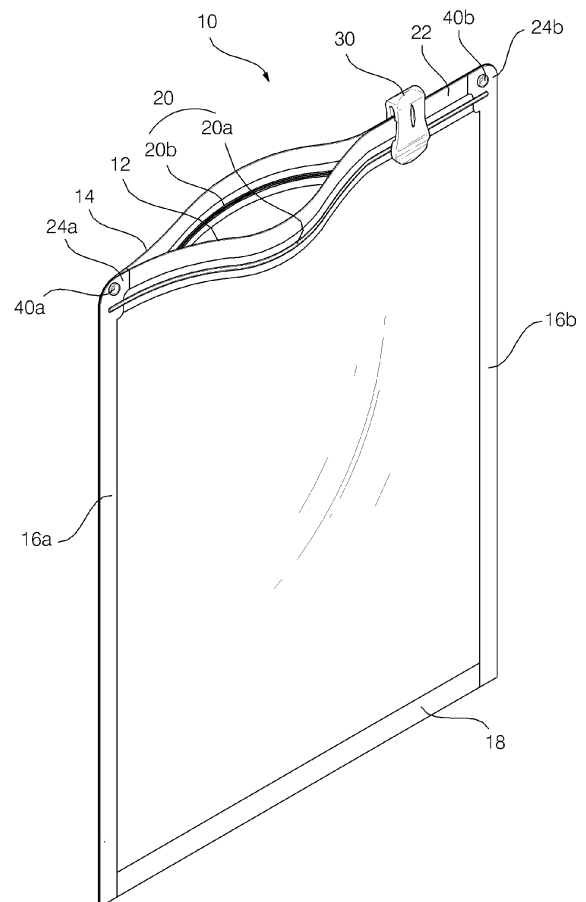

Description

BACKGROUND OF THE INVENTION

1. Technical Field

[0001] The present invention relates to a slider end stop for a reclosable plastic bag and a reclosable plastic bag having the same. More particularly, the present invention relates to a slider end stop for a reclosable plastic bag, which has a through-hole at the center and attached, such as rivet connection.

2. Related Art

[0002] Plastic bags have been widely used in houses and commerce. In particular, plastic bags are frequently used for food storage or packing. Some of the plastic bags have zippers or fasteners at the upper portions to be repeatedly opened and closed. The zippers and fasteners close the upper portion of the plastic bags by engaging two sides. Currently, various types of zippers or fasteners have been proposed.

[0003] Even though engagement of the zipper or fastener can be performed by human hands, this becomes inconvenient to the user. In order to make it easier for a user, a plastic bag having a slider pressing the zipper or fastener in the engagement direction has been proposed. Further, end stops that restrict side movement of the slider are provided to prevent the slider from separating from the ends of the zipper or fastener.

[0004] The configuration of an end stop in the related art is as follow.

[0005] U.S Patent No. 5067208 (published on November 26, 1991) discloses a configuration that prevents a slider from separating by having an end clamp formed of a strap member covering a zipper. A rivet-shaped member is provided to a side of the strap of the end clamp and an opening is formed at the other end, such that a rivet-shaped member is connected to the opening with the strap folded, in which the end clamp is attached to the plastic bag. However, this configuration has a problem in that the configuration of the end clamp is complicated. Further, the end clamp is exposed to the outside at the upper portion of the plastic bag, thereby negating the aesthetic appearance. Meanwhile, there is a problem in that the configuration of the slider disclosed in the above Patent is complicated.

[0006] In another prior art, an end stop formed by deforming a part of the upper portion of a plastic bag using ultrasonic wave or heat and a method of manufacturing the same are disclosed in Korean Patent Publication No. 10-2004-0031660 (published on April 13, 2004, same as U.S Patent Publication No. 2004/0066985). A large number of technologies that form an end stop using heat have been disclosed, other than the above Patent Publication. However, according to the configuration of the end stop, since the upper portion of a plastic bag is de-

formed, the aesthetic appearance is detracted. Further, because a heating process is required, manufacturing is inconvenient.

[0007] Further, end stoppers in the related art are limited in that their only function is to prevent the sliders from separating and they do not have other functions. Meanwhile, there is a problem in that the configurations of the sliders in the related art are complicated and manufacturing the sliders is difficult.

SUMMARY OF THE INVENTION

[0008] Accordingly, it is an object of the present invention to provide an end stop having flange-shaped end stop that prevents a slider, which engages a zipper, from separating from ends of the zipper by being inserted in an insertion hole formed through a first film and a second film of a plastic bag, and a through-hole at the center, and a reclosable plastic bag having the end stop.

[0009] The reclosable plastic bag includes: a first film and a second film of which both sides and lower sides adhere to each other and the combined upper side is open; a zipper including a first zipper and a second zipper that are provided on the insides of the upper sides of the first film and second film and engaged with each other; a slider engaging the first zipper with the second zipper, sliding on the zipper; and end stops of which both ends are formed in flange shapes and that each have a through-hole at the center to prevent the slider from separating from the ends of the zipper by being fitted in insertion holes formed through the first film and the second film.

[0010] The end stop has a body having the through hole and a flange protruding outside from an end of the body, and is fitted in the insertion hole by inserting the body into the insertion hole and then deforming the other end of the body, such as rivet connection.

[0011] Preferably, the insertion hole may be formed at end stop fitting portions of the first film and second film adhering to each other.

[0012] Further, the slider has a first side wall and a second side wall of which ends are connected to be open at a side, and a first curved portion and a second curved portion corresponding to the protruding zipper are respectively formed on the insides of the first side wall and the second side wall.

[0013] Preferably, a first locking protrusion and a second locking protrusion are formed under the first curved portion and the second curved portion of the first side wall and the second side wall of the slider to prevent the slider to separating upward from the zipper.

[0014] Preferably, at least any one of the first side wall and the second side wall of the slider has an end stop fitting hole where the end stop is fitted.

[0015] Preferably, at least any one of the first side wall and the second side wall of the slider has an operation protrusion on the outside.

[0016] Meanwhile, the reclosable plastic bag may fur-

ther include a vacuum valve to vacuum the inside of the plastic bag.

[0017] Preferably, the vacuum valve includes: a lower body including a fusion plate attached to the inside of any one of the first film and the second film and a circular protrusion protruding up from the fusion plate and exposed outside of the film; a rubber packing disposed inside the lower body and functions as a valve; and an upper body including a rim fitted on the outside of the circular protrusion, a cover having a cap fitted on the inner circumference of the circular protrusion, and a connecting strap connecting the rim with the cover.

[0018] According to the invention, a slider end stop that can be simply achieved is provided. The end stop has an advantage of connecting a rope because it has a through-hole at the center. Further, according to the invention, a slider that can be simply manufactured and has durability, and is detachable for reuse, if needed. Therefore, the invention improves ease of manufacturing and convenience of use.

BRIEF DESCRIPTION OF THE DRAWINGS

[0019]

FIG. 1 is a perspective view of a reclosable plastic bag having end stops according to a preferred embodiment of the invention;

FIG. 2 is a perspective view illustrating attaching end stop members to the reclosable plastic bag according to a preferred embodiment of the invention;

FIG. 3 is a cross-sectional view of the end stop members that are attached to the reclosable plastic bag according to a preferred embodiment of the invention;

FIG. 4 is a view illustrating forming an end stop by attaching the end stop member to the reclosable plastic bag according to a preferred embodiment of the invention;

FIG. 5 is a perspective view of the slider for a reclosable plastic bag according to a preferred embodiment of the invention;

FIG. 6 is a side view of the slider for a reclosable plastic bag according to a preferred embodiment of the invention.;

FIG. 7 is a perspective view illustrating the slider stopped by an end stop, in the reclosable plastic bag according to a preferred embodiment of the invention;

FIG. 8 is a view showing an example of attaching a rope to the end stops of the reclosable plastic bag according to a preferred embodiment of the invention;

FIG. 9 is a perspective view of a reclosable plastic bag equipped with a vacuum valve according to a preferred embodiment of the invention;

FIG. 10 is an exploded perspective view of the vacuum valve; and

FIG. 11 is an assembly view of the vacuum valve.

DESCRIPTION OF THE PREFERRED EMBODIMENTS

[0020] Preferred embodiments of the invention are described hereafter in detail with reference to the accompanying drawings. Giving reference numerals to components in each figure, it should be understood first that the same components are referred by the same reference numerals even if they are shown in different figures. Describing the invention herein, when it is considered that detailed description about related known configurations or functions makes the aspects of the invention unclear, the detailed description may be omitted. Further, preferred embodiments of the invention are described hereafter, but it will be apparent to those skilled in the art that various modifications and changes may be made thereto without departing from the scope and spirit of the invention.

[0021] FIG. 1 is a perspective view of a reclosable plastic bag having end stops according to a preferred embodiment of the invention.

[0022] A plastic bag according to the invention includes a first film 12 and a second film 14 that are formed of plastic and adhered to each other with the combined upper side open, a zipper 20 including a first zipper 20a and a second zipper 20b and the open portion of the first film 12 and the second film 14, a slider 30 closing the zipper 20, and end stops 40a, 40b preventing the slider 30 from separating from the ends of the zipper 20.

[0023] The first film 12 and the second film 14 adhere to each other at the left and right sides by side adhering portions 16a, 16b, and the lower sides adhere to each other by lower adhering portions 18, thereby forming a bag. The first film 12 and the second film 14 may be formed of polypropylene, polyethylene, polystyrene, polycarbonate, polyester, polyacetal, or a combination including one or two or more of them.

[0024] The first zipper 20a and the second zipper 20b are provided on the inside of the upper sides of the first film 12 and the second film 14. Each of the first zipper 20a and the second zipper 20b has projections and grooves (not shown), such that the projections and the grooves are correspondingly engaged. The upper side of a plastic bag 10 can be closed by engaging the first zipper 20a with the second zipper 20b. The first zipper 20a and the second zipper 20b are attached slightly lower than the upper end of the first film 12 and the second film 14, such that a small extension 22 remains above the zipper 20.

[0025] The slider 30 is disposed to cover the extension 22 of the plastic bag 10 and the front and rear sides of the zipper 20. The slider 30 may be formed in a U-shape with a side open and inserted from the above of the plastic bag 10. The slider 30 can move, such that first zipper 20a and the second zipper 20b are engaged by moving the slider 30 on the zipper 20 while pressing the front and rear sides of the slider with a hand.

[0026] The end stops 40a, 40b are provided to both ends of the extension 22. The end stops 40a, 40b are attached to both ends of the extension 22, such as rivet. In order to ensure the attachment of the end stops 40a, 40b to both ends of the extension 22, it is preferable that the side adhering portions 16a, 16b extend to the extension 22 to form end stop joints 24a, 24b.

[0027] FIG. 2 is a perspective view illustrating attaching end stop members to the reclosable plastic bag according to a preferred embodiment of the invention, FIG. 3 is a cross-sectional view of the end stop members that are attached to the reclosable plastic bag according to a preferred embodiment of the invention, and FIG. 4 is a view illustrating forming an end stop by attaching the end stop member to the reclosable plastic bag according to a preferred embodiment of the invention.

[0028] Forming the end stops 40a, 40b to the plastic bag 10 is described in detail with reference to FIGS. 2 to 4.

[0029] The members for the end stops 40a, 40b each have a hollow pipe-shaped body 44 and a flange 46 radially protruding from the upper side of the body 44. The members for the end stops 40a, 40b may be formed of the same material as the material of the first film 12 and the second film 14.

[0030] Referring to FIG. 2, insertion holes 42a where the members for the end stops 40a, 40b are formed through the upper portion of the ends of the zipper 20.

[0031] Referring to FIG. 4, the member for the end stop 40a is fitted in the insertion hole 42a by inserting the member for the end stop 40a into the insertion hole 42a and then pressing the lower side of the body 44 with a second anvil 48b while supporting the upper side of the flange with a first anvil 48a, thereby forming the end stop 40a. This process is similar to fitting a rivet into plates overlapping.

[0032] As a result, both ends, which are exposed to the outside, of each of the end stops 40a, 40b fitted in the insertion holes 42a are formed in circular flange shapes, which can be considered to be connected with the hollow bodies 44.

[0033] The slider 30 that is suitable to the end stops 40a, 40b of the plastic bag 10 according to a preferred embodiment of the invention is described next.

[0034] FIG. 5 is a perspective view of the slider for a reclosable plastic bag according to a preferred embodiment of the invention and FIG. 6 is a side view of the slider for a reclosable plastic bag according to a preferred embodiment of the invention.

[0035] The slider 30 is formed in a U-shape with a first side wall 32a and a second side wall 32b of which ends are connected. The following description is provided on the assumption that the connection of the first side wall 32a and the second side wall 32b of the slider is the upper side and the open side is the lower side.

[0036] A first end stop locking groove 34a is formed on the inside of the first side wall 32a and a first curved portion 38a corresponding to the first zipper 20a protruding outside is formed under the first end stop locking

groove 34a. Further, a first locking protrusion 36a is formed under the first curved portion 38a on the first side wall 32a to prevent the slider 30 from separating upward from the zipper 20. Similarly, a second end stop locking groove 34b, a second curved portion 38b, and a second locking protrusion 36b are formed on the second side wall 32b. It is preferable that the pairs of the first and second end stop locking grooves 34a, 34b are formed at left and right sides on the first side wall 32a and the second side wall 32b, respectively. The first and second end stop locking grooves 34a, 34b may be preferably formed in semicircular shapes, corresponding to the end stops 40a, 40b.

[0037] The slider 30 is attached on the upper side of the plastic bag 10 such that the zipper 20 is disposed between the first curved portion 38a and the second curved portion 38b. Therefore, the slider cannot be easily separated from the zipper 20. Further, the locking protrusions 36a, 36b provided at the lower side on the insides of the slider 30 additionally prevent the slider 30 from separating from the zipper 20.

[0038] On the other hand, first and second operation protrusions 39a, 39b protrude from the outsides of the first side wall 32a and the second side wall 32b to allow a user to easily move the slider to the left and right.

[0039] FIG. 7 is a perspective view illustrating the slider stopped by an end stop, in the reclosable plastic bag according to a preferred embodiment of the invention.

[0040] Even though the slider 30 moves to an end of the zipper 20 along the outsides of the zipper 20, it is stopped by the end stop 40a and cannot be separated from the zipper 20. In particular, when the slider 30 has the end stop locking groove 34a, the end stop 40a is locked into the end stop locking groove 34a of the slider 30, thereby ensuring the slider 30 stops.

[0041] FIG. 8 is a view showing an example of attaching a rope to the end stops of the reclosable plastic bag according to a preferred embodiment of the invention.

[0042] As described above, according to the invention, the end stops 40a, 40b preferably have through-holes and are attached to the upper side of the plastic bag, such rivet connection.

[0043] Therefore, a rope 49 can be inserted in the through-holes in the end stops 40a, 40b. Accordingly, the user can easily carry or hang the plastic bag 10 by connecting the rope 49 to the plastic bag 10.

[0044] Another preferred embodiment of the invention is provided hereafter.

[0045] The use of vacuum packing bags has rapidly increased in recent years to effectively store food.

[0046] FIG. 9 is a perspective view of a reclosable plastic bag equipped with a vacuum valve, FIG. 10 is an exploded perspective view of the vacuum valve, and FIG. 11 is an assembly view of the vacuum valve.

[0047] The vacuum valve 50 is equipped to any one of the first film 12 and the second film 20 of a plastic bag 10, and functions as a one-way valve.

[0048] Referring to FIGS. 10 and 11, the vacuum valve

includes a lower body 52, a rubber packing 60, and an upper body 66.

[0049] The lower body 50 includes a fusion plate 54 and a circular protrusion 56 protruding up from the fusion plate 54 adheres to the inside of the film (12 or 14) of the plastic bag 10 and the circular protrusion 56 protrudes outside from the inside of the film (12 or 14).

[0050] The rubber packing 60 includes a contact plate 60, a conical protrusion 64, and a connecting bar 64. The rubber packing 60 is combined with the lower body 50.

[0051] The upper body 99 includes a doughnut-shaped rim 68, a cover 72, and a connecting strap 74 connecting the rim 68 with the cover 72. The rim 68 is fitted on the outer circumference of the circular protrusion 56. It is preferable that the rim 68 is force-fitted to the circular protrusion 56 to prevent the rim 68 from separating after being fitted. The cover 72 has a circular cap 70 that protrudes to ensure sealing the vacuum valve 50 by being attaching to the inner circumference of the circular protrusion 56. Further, the cover 72 has a protruding handle 73.

[0052] According to this configuration, the lower body 52 is attached to the inside of the film (12 or 14) and then the upper body 66 can be easily combined with the lower body 52 from the outside of the film (12 or 14).

[0053] Although the preferred embodiments of the invention have been disclosed for illustrative purposes of spirit of the invention, those skilled in the art will appreciate that various modifications, additions and substitutions are possible, without departing from the scope and spirit of the invention. Therefore, it should be understood that the above embodiments and the accompanying drawings are not limitative, but illustrative for spirit of the invention, and the spirit of the invention is not limited to the embodiments and accompanying drawings. The scope of the invention should be construed by the appended claims and all spirits within equivalences of the claims are intended to be embraced by the claims.

Claims

1. A reclosable plastic bag comprising:

a first film and a second film of which both sides and lower sides adhere to each other and the combined upper side is open;

a zipper including a first zipper and a second zipper that are provided on the insides of the upper sides of the first film and second film and engaged with each other;

a slider engaging the first zipper with the second zipper, sliding on the zipper; and

end stops of which both ends are formed in flange shapes and that each have a through-hole at the center to prevent the slider from separating from the ends of the zipper by being fitted in insertion holes formed through the first film

and the second film.

2. The reclosable plastic bag of claim 1, wherein the end stop has a body having the through hole and a flange protruding outside from an end of the body, and is fitted in the insertion hole by inserting the body into the insertion hole and then deforming the other end of the body, such as rivet connection.

3. The reclosable plastic bag of claim 1 or 2, wherein the insertion hole is formed at end stop fitting portions of the first film and second film adhering to each other.

4. The reclosable plastic bag of claim 3, wherein the end stop fitting portion is positioned at the upper side of the zipper.

5. The reclosable plastic bag of claim 1 or 2, wherein the slider has a first side wall and a second side wall of which ends are connected to be open at a side, and a first curved portion and a second curved portion corresponding to the protruding zipper are respectively formed on the insides of the first side wall and the second side wall.

6. The reclosable plastic bag of claim 5, wherein a first locking protrusion and a second locking protrusion are formed under the first curved portion and the second curved portion of the first side wall and the second side wall to prevent the slider to separating upward from the zipper.

7. The reclosable plastic bag of claim 5, wherein at least any one of the first side wall and the second side wall has an end stop fitting hole where the end stop is fitted.

8. The reclosable plastic bag of claim 5, wherein at least any one of the first side wall and the second side wall has an operation protrusion on the outside.

9. The reclosable plastic bag of claim 1 or 2, further comprising a vacuum valve to vacuum the inside of the plastic bag.

10. The reclosable plastic bag of claim 9, wherein the vacuum valve includes:

a lower body including a fusion plate attached to the inside of any one of the first film and the second film and a circular protrusion protruding up from the fusion plate and exposed outside of the film;

a rubber packing disposed inside the lower body and functions as a valve; and

an upper body including a rim fitted on the outside of the circular protrusion, a cover having a

cap fitted on the inner circumference of the circular protrusion, and a connecting strap connecting the rim with the cover.

11. The end stop preventing the slider, which engages the zipper of the reclosable plastic bag, from separating from a side, wherein the end stop has a body having flange-shaped both ends and a through-hole at the center and is fitted in an insertion hole through a first film and a second film of the plastic bag. 5
10
12. The end stop of the reclosable plastic bag, which has a flange at an end of the body and is fitted in the insertion hole by inserting the body into the insertion hole and then deforming an end of the body, such as rivet connection, to form another flange. 15

20

25

30

35

40

45

50

55

[FIG. 1]

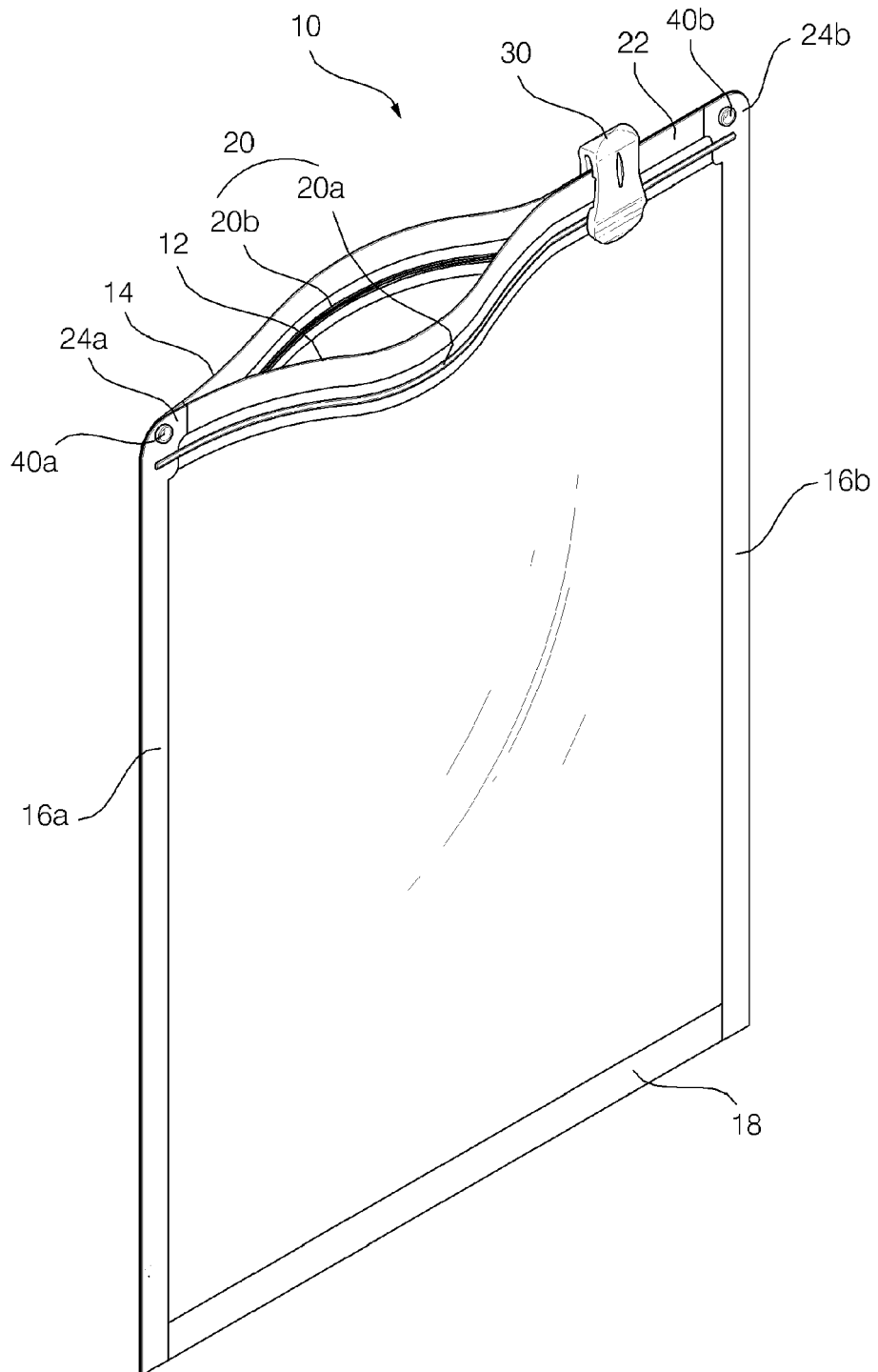

[FIG. 2]

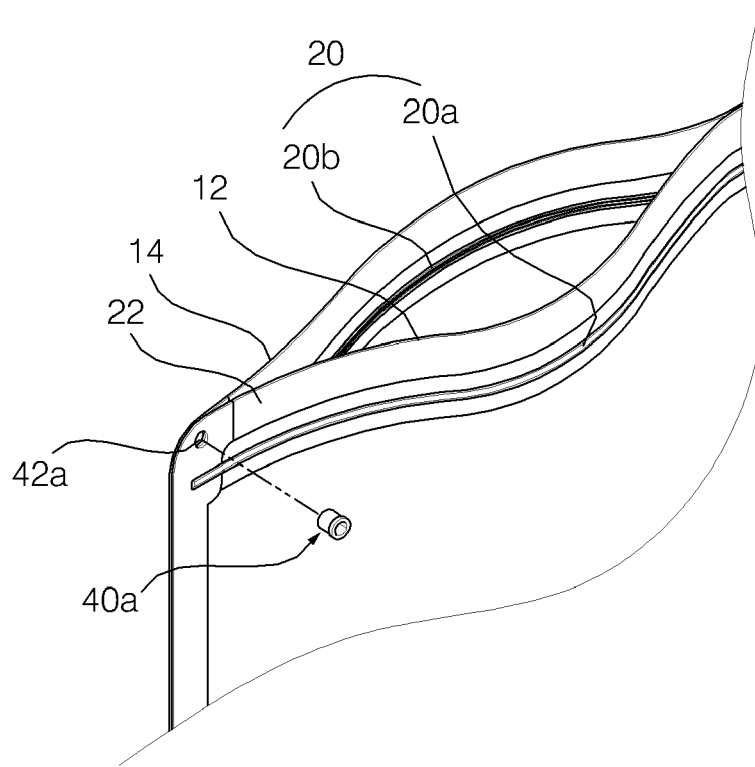

[FIG. 3]

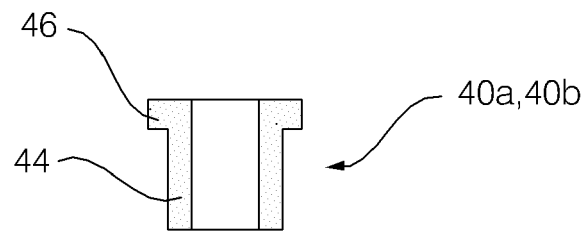

[FIG. 4]

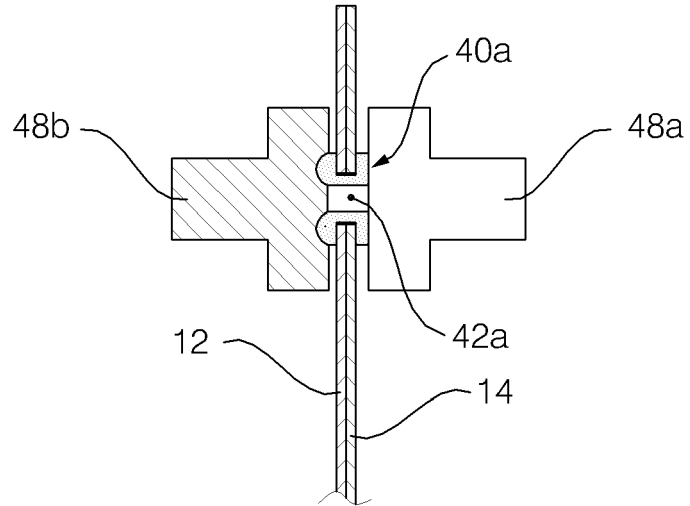

[FIG. 5]

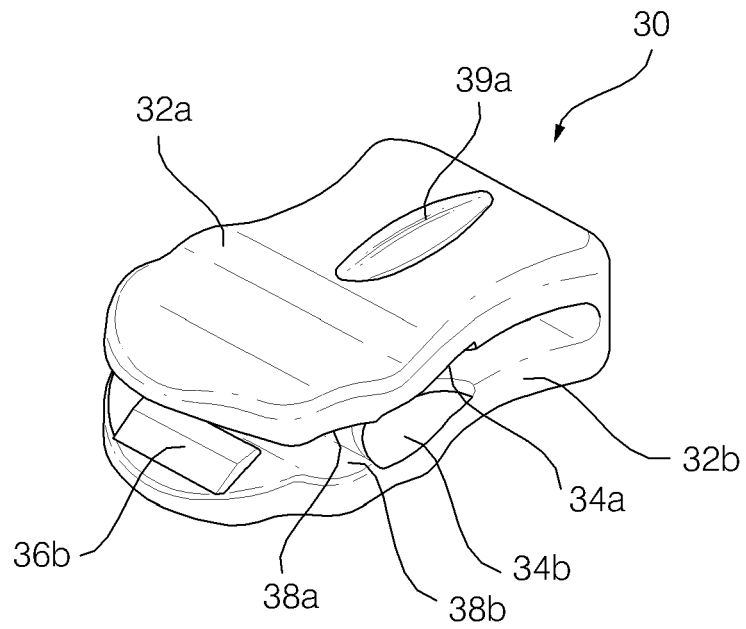

[FIG. 6]

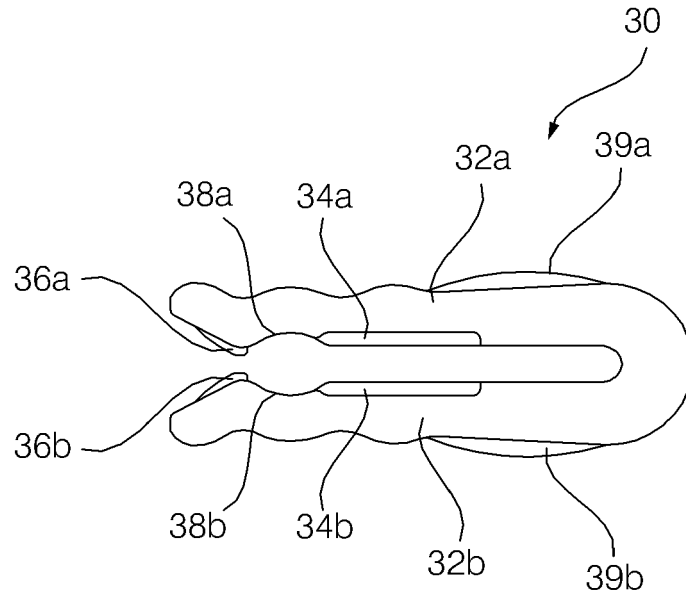

[FIG. 7]

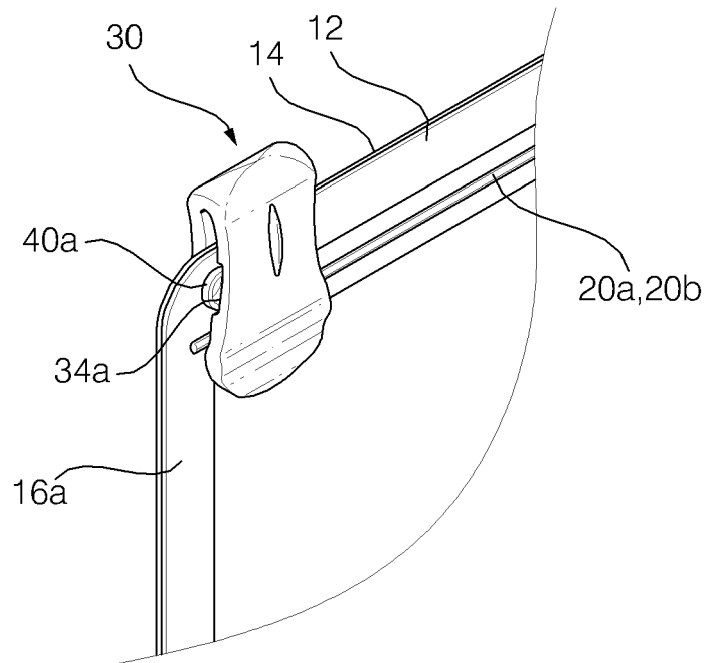

[FIG. 9]

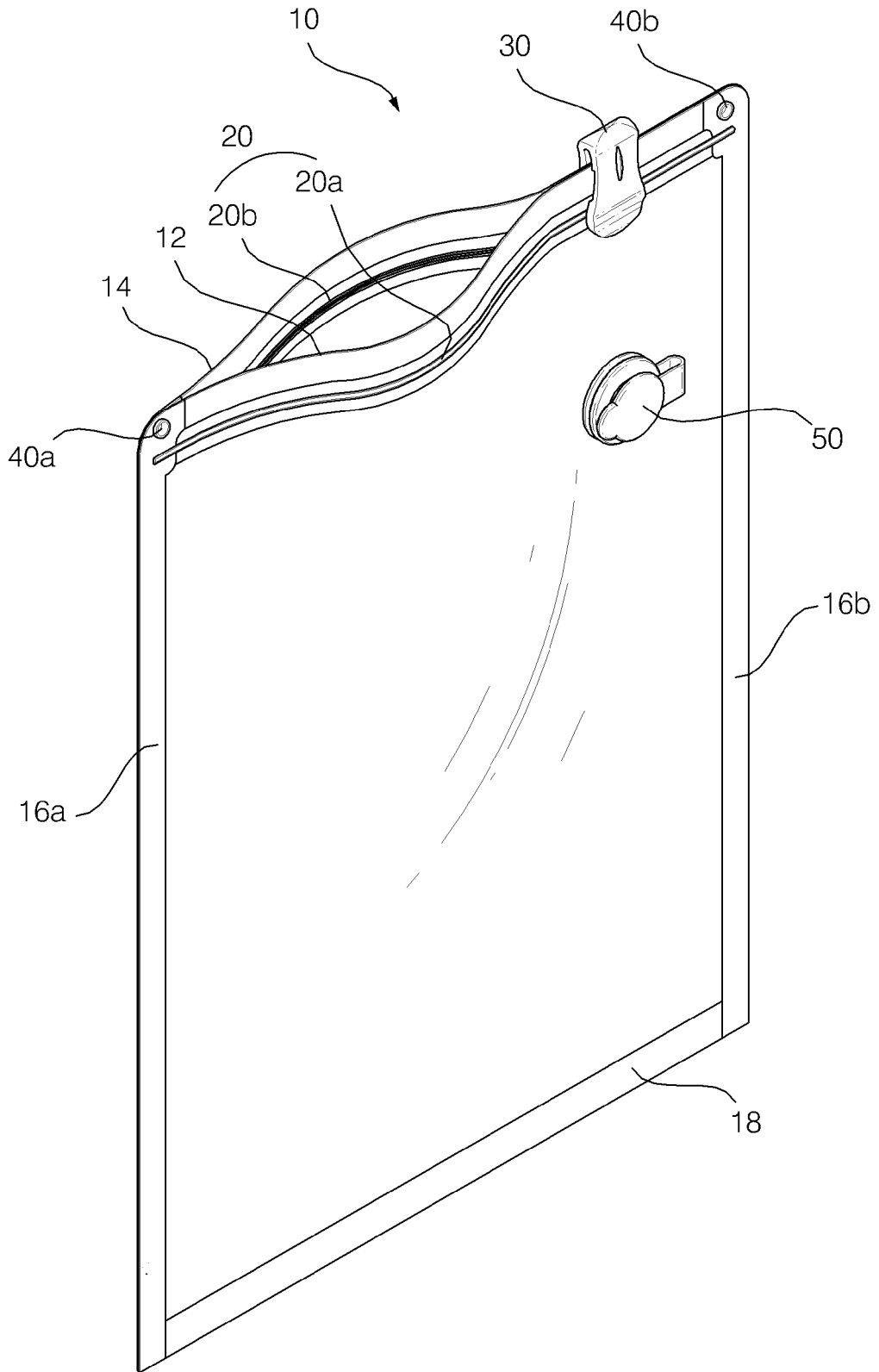

[FIG. 10]

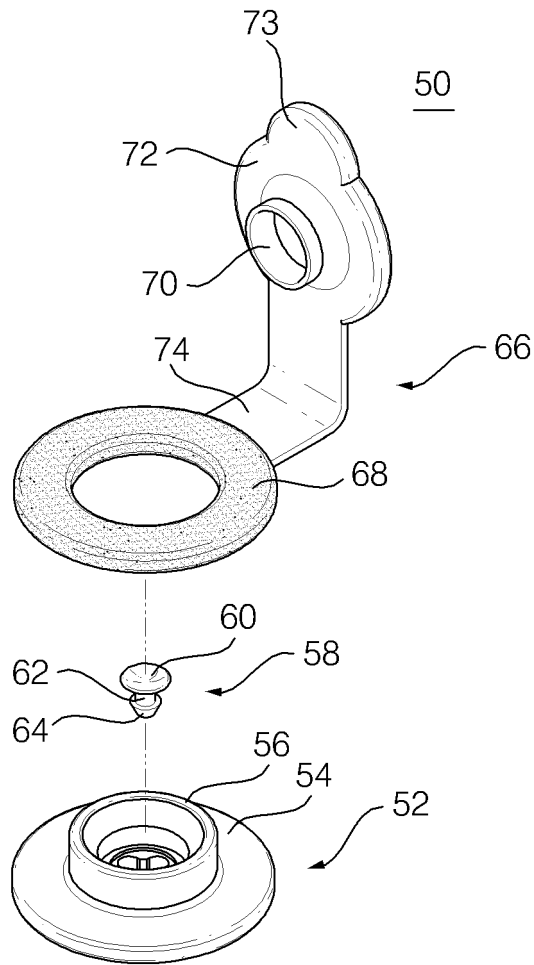

[FIG. 11]

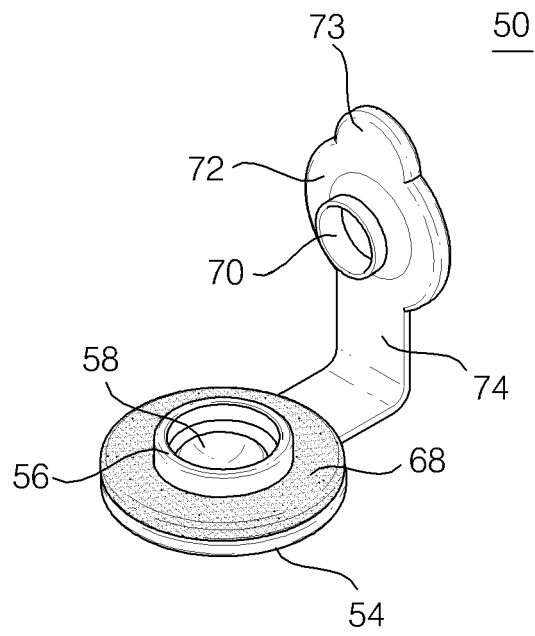

REFERENCES CITED IN THE DESCRIPTION

This list of references cited by the applicant is for the reader's convenience only. It does not form part of the European patent document. Even though great care has been taken in compiling the references, errors or omissions cannot be excluded and the EPO disclaims all liability in this regard.

Patent documents cited in the description

- US 5067208 A [0005]
- KR 1020040031660 [0006]
- US 20040066985 A [0006]