

(12) PATENT
(19) AUSTRALIAN PATENT OFFICE

(11) Application No. AU 199875441 B2
(10) Patent No. 746584

(54) Title
A method for electronically beam forming acoustical signals and acoustical sensor apparatus

(51)⁶ International Patent Classification(s)
H04R 003/00 H04R 025/00

(21) Application No: 199875441 (22) Application Date: 1998 .06 .08

(87) WIPO No: W099/09786

(30) Priority Data

(31) Number	(32) Date	(33) Country
97114413	1997 .08 .20	EP

(43) Publication Date : 1999 .03 .08
(43) Publication Journal Date : 1999 .05 .06
(44) Accepted Journal Date : 2002 .05 .02

(71) Applicant(s)
Phonak AG

(72) Inventor(s)
Joseph Maisano; Werner Hottinger

(74) Agent/Attorney
GRIFFITH HACK,GPO Box 1285K,MELBOURNE VIC 3001

(56) Related Art
EP 0652686
J.E. GREEBERG,P.M. ZUREK:"EVALUATION." JNL. VOL.91 NO.3 1992

OPI DATE 08/03/99 APPLN. ID 75441/98
 AOJP DATE 06/05/99 PCT NUMBER PCT/IB98/00889



AU9875441

INTE

<p>(51) International Patent Classification ⁶ : H04R 3/00, 25/00</p>	<p>A1</p>	<p>(11) International Publication Number: WO 99/09786 (43) International Publication Date: 25 February 1999 (25.02.99)</p>
<p>(21) International Application Number: PCT/IB98/00889 (22) International Filing Date: 8 June 1998 (08.06.98) (30) Priority Data: 97114413.4 20 August 1997 (20.08.97) EP (34) Countries for which the regional or international application was filed: CH et al. (71) Applicant (for all designated States except US): PHONAK AG [CH/CH]; Laubisrütistrasse 28, CH-8712 Stäfa (CH). (72) Inventors; and (75) Inventors/Applicants (for US only): MAISANO, Joseph [IT/CH]; Rue Grise Pierre 3, CH-2000 Neuchâtel (CH). HOTTINGER, Werner [CH/CH]; Chemin Trois Portes 65, CH-2003 Neuchâtel (CH). (74) Agent: TROESCH SCHEIDEGGER WERNER AG; Siewerdstrasse 95, CH-8050 Zürich (CH).</p>	<p>(81) Designated States: AL, AM, AT, AU, AZ, BA, BB, BG, BR, BY, CA, CH, CN, CU, CZ, DE, DK, EE, ES, FI, GB, GE, GH, GM, GW, HU, ID, IL, IS, JP, KE, KG, KP, KR, KZ, LC, LK, LR, LS, LT, LU, LV, MD, MG, MK, MN, MW, MX, NO, NZ, PL, PT, RO, RU, SD, SE, SG, SI, SK, SL, TJ, TM, TR, TT, UA, UG, US, UZ, VN, YU, ZW, ARIPO patent (GH, GM, KE, LS, MW, SD, SZ, UG, ZW), Eurasian patent (AM, AZ, BY, KG, KZ, MD, RU, TJ, TM), European patent (AT, BE, CH, CY, DE, DK, ES, FI, FR, GB, GR, IE, IT, LU, MC, NL, PT, SE), OAPI patent (BF, BJ, CF, CG, CI, CM, GA, GN, ML, MR, NE, SN, TD, TG).</p> <p>Published With international search report.</p>	

(54) Title: A METHOD FOR ELECTRONICALLY BEAM FORMING ACOUSTICAL SIGNALS AND ACOUSTICAL SENSOR APPARATUS

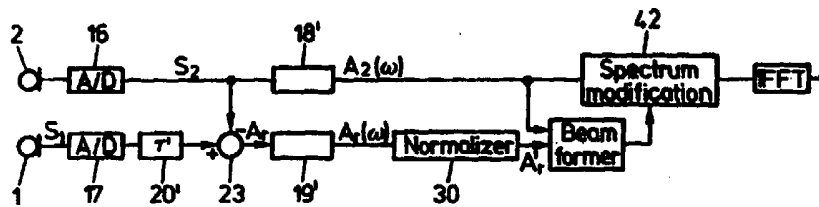

(57) Abstract

A predetermined characteristic of amplification in dependency of the direction (θ) from which acoustical signals are received at two spaced-apart acoustical/electrical transducers (1, 2) is formed in that repetitively a mutual delay signal (A_{10}) is determined from the output signals of the transducers and according to the reception delay at the transducers, one (S_1) of the output signals is filtered, thereby the filtering transfer characteristic is controlled in dependency of the mutual delay signal (A_{12}). The output signal of the filtering (14) is exploited as electrical reception signal (S_2).

- 1 -

A method for electronically beam forming acoustical signals and acoustical sensor apparatus

The present invention is generically directed on a technique for so-called "beam forming" on acoustical signals.

5 The use of directional acoustical/electrical transducers and especially of such microphones is one of the most efficient ways for improving signal to noise ratio in audio systems. It is known to realise directional microphones by using an array of microphone cells and time delaying and superimposing the
10 output signals of such cells following up the known "delay and sum" technique.

With two omnidirectional microphone cells this known principle is shown in fig. 1. Two omnidirectional microphones, 1 and 2, are provided with a mutual distance p . The output signal of one
15 of the microphones according to signal A_1 is time delayed by the time amount τ , the time delayed signal according to A_1' is superimposed at a superimposing unit 3 to the undelayed output signal A_2 of microphone 2. At the output of the superimposing unit 3 there results the output signal A_r with an amplification
20 versus impinging angle θ characteristic, as shown in fig. 2 for one frequency ω considered. Thereby, it is customary to select as delay time τ as the quotient of distance p and velocity of sound c . With this arrangement there results, as shown in fig. 2, a first order cardoid characteristic. It may be shown that
25 the amplitude of the resulting signal A_r is proportional to the sine of the signal frequency ω and to the distance p . The maximum gain in target direction (180°) occurs at the frequency $f_r = c/(4p)$. For a distance p of 12 mm, f_r becomes approx. 7 kHz.

- 2 -

By staggering more than one of the fig. 1 double-cell arrangements and superimposing the resulting signals A_i of the more than one double-cell arrangements, higher order cardoid characteristics may be realised.

5 In fig. 3 a known arrangement to realise second order cardoid characteristics according to fig. 4 is shown. Thereby, a narrower beam can be achieved. The higher the order of the directional microphone arrangement, the higher becomes the directivity index and the gain at f_r , but the higher will also be the
10 roll-off for low and high frequencies and the number of unwanted side-lobes. With respect to the definition of the directivity index please refer to speech communication 20 (1996), 229 - 240, "Microphone array systems for hands-free telecommunications", Garry W. Elko.

15 In fig. 5 there is shown the gain versus frequency characteristic of the first and second cardoid characteristics for an impinging angle $\theta = 180^\circ$. Therefrom, high and low frequency roll-offs are clearly evident.

Such techniques for beam forming are well-known and have been
20 realised using analogue signal processing, as e.g. shown in the US-A-2 237 298, US-A-4 544 927, US-A-4 703 506, US-A-5 506 908 or using digital signal processing, both in time or in frequency domain, as shown in the EP-A-0 381 498 (time domain) or in the US-A-5 581 620 (frequency domain).

25 Beam formings realised with any of these principles has the following drawbacks:

- a) The resulting signal is dampened at low frequencies, which results in a bad signal to noise ratio.

- 3 -

- b) The directivity index is very sensitive to matching of the individual microphone cells, especially at low frequencies.
- c) The distance p between the microphone cells should be large (> 12 mm) for audio range.
- 5 d) The frequency band with a high gain in target direction is rather small, as may clearly be seen from fig. 5.
- e) The directivity largely depends upon the number of microphone cells and thus on the complexity of the overall arrangement.
- 10 f) As one aims for a high directivity by increasing the number of cells, more unwanted side-lobes are introduced.

Several techniques have been proposed to overcome some of these drawbacks:

15 In the WO 95/20305 (E. Lindemann) an adaptive noise reduction system for use in binaural hearing aid is proposed. It detects the power of the received signals to separate the desired from unwanted signals.

20 There is proposed a "broad side" microphone-cell array, i.e. target direction is perpendicular to the axis from one microphone to the other, in contrary to the arrangement according e.g. to Fig. 1 and the principles of the present invention, which is "in line".

The disclosed apparatus is bulky ($>> 5$ cm), so that it may not be implemented for one ear hearing aid.

- 25 Two equal beam lobes are generated in target and in opposing directions.

- 4 -

In such a hearing aid a connection between the left and right ear system must be present, making the apparatus for hearing aid unhandy. Furthermore, as described by the same author in "Two microphone non-linear frequency domain beam former for hearing aid noise reduction" 1995, IEEE ASSP Workshop on Applications of Signal Processing to Audio and Acoustics, October 15 - 18, Mohonk, New Paltz, New York, such beam forming is efficient only up to about 2 kHz and leads to distortions of the desired signals.

10 The US-A-4 653 102 proposes the use of two directional microphones aimed in target direction and of a third microphone aimed in opposite direction. The signal of the third microphone supposedly only containing noise is used to shape the response of the two primary microphones. This technique obviously has
15 the drawback within reverberating rooms, where the desired signal is reflected on walls, floor, ceiling and furniture and is therefore considered as noise by the system. This technique is further unhandy as making use of at least three microphones.

Attention is further drawn to US-A 5 400 409 and 5 539 859.

20 As an example of known beam-forming techniques, the US-5 539 859 proposes a technique wherein reception characteristic is logged in on that direction wherefrom the highest energy impinges on a pair of microphones and considered in the sound environment. Principally, all sound impinging from directions
25 other than from highest energy direction is considered as noise and its reception is cancelled.

Thereby, an analogue to digital conversion and subsequent time to frequency domain conversion is performed on the output signals of two microphones. Exploiting the knowledge of the fixed

- 5 -

mutual distance between the two microphones, wherefrom phase difference of the impinging signal spectra is dependent, there is determined the mutual phasing and thus impinging direction of highest energy sound signals, i.e. direction of highest energy sound source within the acoustical surrounding. Signals
5 impinging from that direction are amplified by means of in-phase shifting and adding similarly to an auto correlation technique, whereby signals from other impinging angles are cancelled as noise.

10 By such a technique the energy distribution in the sound environment traps the selectivity of reception, and it is not possible to freely select or preselect a maximum reception characteristic, e.g. in direction wherefrom sound is desired to be selectively received, irrespective of its relative energy. One
15 field whereat such selectivity irrespective of energy distribution within the sound surrounding would clearly be advantageous is hearing aid technique.

It is an object of the present invention to provide a method for electronically forming a predetermined characteristic of
20 amplification in dependency of direction from which acoustical signals are received at at least two spaced apart acoustical/electrical transducers and a respective acoustical sensor apparatus, with which only a small number of microphones or microphone cells has to be used and which is thus enabling small
25 and compact directional transducer or microphone realisation. Thereby, the preferred apparatus according to the present invention is a hearing aid apparatus, and especially a one ear hearing aid apparatus.

It is a further object to provide such method and apparatus with good frequency response in the audio band, i.e. between approx. 0,1 and 10 kHz.

5 Still a further object of the present invention is to provide such method and apparatus which allow high signal to noise ratio realisation without unwanted side-lobes and with easily variable beam form, e.g. for acoustical zooming.

10 These and other objects are realised by the inventive method, which comprises the steps of repetitively determining from signals dependent from the acoustical signals a respective mutual delay signal according to reception delay at the at least two transducers; subjecting a signal dependent from the output signal of at least one of the at least two transducers to filtering with a filtering transfer characteristic; and of controlling the filtering transfer characteristic in dependency of the mutual delay signal; further exploiting a signal dependent from the output signal of the filtering as electrical reception signal.

15
20
25

According to a first aspect of the present invention, there is provided a method for electronically forming a predetermined characteristic of amplification in dependency of direction from which acoustical signals are received at at least two spaced apart acoustical/electrical transducers, comprising, at least within a predetermined frequency band, the steps of:

20
25

- repetitively determining from signals dependent from said acoustical signals a respective mutual delay signal according to reception delay at said at least two transducers;



- subjecting a signal dependent from the output signal of at least one of said at least two transducers to filtering with a filtering transfer characteristic;
- 5 - controlling said filtering transfer characteristic in dependency of said mutual delay signal;
- exploiting a signal dependent from the output signal of said filtering as electrical reception signal.

10

According to a second aspect of the present invention, there is provided an acoustical sensor apparatus comprising:

- 15 - at least two acoustical/electrical transducers at a predetermined mutual distance;
- a time delay detection unit which at least two inputs and an output, the inputs thereof being respectively
- 20 operationally connected to the outputs of said at least two transducers, said time delay detection unit generating an output signal in dependency of the time delay of acoustical signals impinging on said at least two transducers;
- 25 - a weighting unit with a predetermined weighting characteristic and with an input and with an output, the input thereof being operationally connected to the output of said time delay detection unit;
- 30 - a filter unit with a controllable transfer characteristic and with at least one input, a characteristic control input and an output, the input thereof being operationally connected to the output of at least one of said at least two transducers, the
- 35 control input thereof being operationally connected to the output of said weighting unit, the filter unit



- generating an output signal in dependency of its input signal and said characteristic controlled by the signal applied at said control input, being dependent from said output signal of said delay detection unit converted by
5 said weighting characteristic of said weighting unit.

Other objects, advantages and specific embodiments of the present invention shall be exemplified with the help of further figures. The figures show:

Fig. 1: A functional block diagram of a two-cell directional microphone arrangement according to the prior art principle of "delay and sum";

Fig. 2: the first order cardioid amplification characteristic of prior art arrangement according to fig. 1;

Fig. 3: departing from the prior art arrangement of fig. 1 a further arrangement following up the technique of

2
3
4
5
6
7
8
9



"delay and sum" for realising second order characteristic;

- Fig. 4: the second order amplification characteristic as realised by the prior art arrangement according to fig. 3;
- 5 Fig. 5: in dependency of frequency the amplification characteristic of the arrangement according to fig. 1 or 3 at maximum amplification impinging angle of acoustical signals;
- Fig. 6: a simplified functional block diagram of an inventive apparatus operating according to the inventive method
10 and further showing the sequence of process signals;
- Fig. 7: in a representation according to fig. 6 a first preferred realisation form of an inventive apparatus operating according to the inventive method;
- 15 Fig. 8: in an inventive apparatus operating according to the inventive method according to fig. 6 a further preferred form of realisation of a time delay detection unit;
- Fig. 9: a polar diagram of signals as realised by the embodiment of fig. 8 for explaining operation of a comparator unit as provided in the fig. 8 embodiment;
20
- Fig. 10: the course of comparison results in dependency of impinging angle of an acoustical signal and as realised by the embodiment according to fig. 8;

- Fig. 11: a preferred form of realising superimposing result signal dependency from impinging angle of an acoustical signal at an embodiment according to fig. 8;
- 5 Fig. 12: in a representation according to fig. 10 the course of comparison results as realised with a preferred embodiment resulting in the fig. 11 dependency;
- 10 Fig. 13: in polar diagrammatic representation the dependency of superimposing result signals from impinging angle of acoustical signals and from frequency as realised by the embodiment according to fig. 8;
- Fig. 14: a preferred realisation form of the fig. 8 embodiment, additionally counteracting frequency dependency as shown in fig. 13;
- 15 Fig. 15: in a representation according to fig. 13 the dependency of the superimposing result signal with normalisation as realised by the embodiment of fig. 14 with a first preferred normalisation frequency function;
- 20 Fig. 16: a representation according to fig. 15, realised with a second preferred normalisation frequency function at the embodiment of fig. 14;
- Fig. 17: a first (rigid line) and second (dashed line) preferred realisation form of amplitude filter characteristic at the embodiment of fig. 6 or 7;
- 25 Fig. 18a: the effect of the amplitude filter amplitude versus amplitude transfer characteristic according to fig. 17 (rigid line) on the output signal of the delay detec-

- 10 -

tion unit as provided in the embodiment of fig. 6 or 7;

5 Fig. 18b: the representation of the output signal of a time delay detection unit passed through the amplitude filter with a transfer characteristic according to fig. 17 (rigid line) and as realisable by the embodiment of fig. 6 or 7;

10 Fig. 19: the spectrum of an acoustical signal converted into electrical and input to a controllable frequency filter as provided by the present invention according to fig. 6;

15 Fig. 20: the electrical reception result signal realised by amplitude filter characteristic according to fig. 17 (rigid line) and reception signal as exemplified in fig. 19 at the inventive embodiment according to fig. 6;

20 Fig. 21: the resulting dependency of amplification from impinging angle of an acoustical signal as realised by the fig. 17 amplitude filter characteristic (rigid and dashed lines);

25 Fig. 22: the amplification versus impinging angle characteristic as realised by the fig. 6 or fig. 8, 14 embodiments of the invention, making use of an amplitude filter characteristic with a maximum to minimum spectral amplitude transfer behaviour;

Fig. 23: in a simplified signal/functional block diagram a further preferred embodiment of the invention;

Fig. 24: in a signal flow, functional block representation, a further mode of realisation of the time delay detection unit as shown in fig. 6 and

5 Fig. 25: in a signal flow, functional block representation, a further mode of realisation of the time delay detection unit following the technique as shown in fig. 8 or fig. 14.

In fig. 6 there is shown in form of a functional block diagram, together with principle signal processing diagrams, the principle of the inventive method and apparatus.
10

At least two acoustical/electrical transducers 1 and 2, as especially of microphones or microphone cells, are provided with a predetermined mutual distance p along axis a . Acoustical signals IN are received by the transducers 1 and 2 as they impinge
15 from different spatial directions θ . The acoustical signals IN have frequency spectra which vary in time. Output signals of transducer 1, $S_1(t, \omega)$ and of transducer 2, $S_2(t, \omega)$, are formed as electrical signals at the output of the transducers 1 and 2. Due to the mutual distance p of the two transducers 1 and 2 -
20 which is preferably smaller than 5 cm, preferably between 0,5 and 1,5 cm, especially for the inventive sensor being a one ear hearing aid apparatus - and as shown with the two respective pointer diagrams below the functional block diagram of fig. 6, the acoustical signals IN impinge on the transducers 1 and 2
25 with a time delay dt , which may be expressed by the phase difference $\Delta\varphi_\omega$ at each spectral frequency ω according to

$$(1) \quad \Delta\varphi_\omega = \omega \cdot dt_\omega, \text{ where}$$

$$(2) \quad dt_{\omega} = \frac{P}{c} \cos \theta_{\omega}.$$

If the source of acoustical signal IN is a point source, then the time delay dt_{ω} becomes equal for all spectral components at the different ω . The output signals S_1 and S_2 of the transducers 1 and 2 are operationally connected to the respective inputs of a time delay detection unit 10, which generates an output signal A_{10} according to the spectral distribution of time delays dt_{ω} , which are, as was explained, a function of the impinging angle θ at which the respective frequency components

impinge on the transducers 1 and 2 and thus in fact of θ_{ω} . Purely as example a possible spectrum of output signal A_{10} is also shown in fig. 6. This spectrum varies in time according to the time variation of impinging acoustical signal IN. The output signal A_{10} of time delay detection unit 10 is input to a weighting unit 12. As the spectrum of dt_{ω} with respective spectral amplitudes of A_{10} is input to the weighting unit 12 with the preselected weighting transfer characteristic W , there results at a certain moment in time, as an output signal A_{12} , a spectral signal $W(\omega)$, as also shown as an example in fig. 6. A_{12} results from respectively weighting the spectral amplitudes of A_{10} according to the characteristic W . As A_{10} indicates according to dt_{ω} from which direction θ_{ω} each frequency component of the acoustical signal IN impinges, its specific weighting by means of function W is nothing else than predetermining which impinging directions θ_{ω} shall be amplified or attenuated. Thus, the weighting unit 12 determines with its characteristic W the beam shape.

The output signal A_{12} is applied to a filter unit 14 with a controllable transfer filter characteristic. There, each spec-



tral line of the time varying spectrum of the output signal $S_1(t, \omega)$ is amplified or attenuated according to the controlling spectrum $W_\omega \cdot A_{10\omega}$. Thus, unit 14 is a filter unit for input signal S_1 at which the transfer characteristic is varied, as
5 controlled by A_{12} . In dependency of the kind of filter unit 14 the weighting unit 12, generally spoken, calculates adjustment of filter characteristic determining coefficients as a function of A_{10} .

Thus, along the channels 10 and 12 there is predetermined by
10 the weighing transfer function W which spatial directions θ shall be "aimed" at. At the filter unit 14 this beam shaping information is applied to the electrical analogon S_1 of the acoustical signal IN , thus resulting in an output signal $S_r(t, \omega)$ representing the shaped reception signal.

By adjusting the weighting transfer function W by applying a
15 control signal C_w to a control input C_{12} , the beam form can be adjusted and thus acoustical zooming is realised.

As shown in dashed line, it may be advantageous to subject both
20 transducer output signals to a controlled filtering at unit 14.

In fig. 7 there is shown a first preferred form of realisation
of the inventive principle according to fig. 6. Thereby, the
output signals S_1 and S_2 are first converted from analogue to
digital form in respective analogue/digital converters 16 and
17. The digital output signals of the respective converters 16
25 and 17 are input to respective complex time domain/frequency
domain converters 18 and 19.

The output spectra $S_1(t, \omega)$ and $S_2(t, \omega)$ of converters 18, 19 are
input to the spectral time delay detection unit 10'. Unit 10'



computes according to formula (1) the phase difference spectrum $\Delta\varphi_{\omega}$ divided by the respective frequency ω to result in an output signal spectrum A_{10}' according to the time delay dt_{ω} as was explained in connection with fig. 6. The output signal of the time delay detection unit 10', A_{10}' , is further treated, as was explained in connection with fig. 6, by the weighting filter unit 12 and the controllable filter unit 14. In the following table there is exemplified how the unit 10' operates. Out of the spectral phase distribution φ_{1n} of signal S_1 and φ_{2n} of signal S_2 , the time delay dt_{ω} is calculated for each spectral line within an interesting spectral band.

	ω_1	ω_2	ω_3			ω_n
S1 (ω)	A_{11}	A_{12}	A_{13}			A_{1n}
	φ_{11}	φ_{12}	φ_{13}			φ_{1n}
S2 (ω)	A_{21}	A_{22}	A_{23}			A_{2n}
	φ_{21}	φ_{22}	φ_{23}			φ_{2n}

$dt_{\omega n}$	$\varphi_{11} - \varphi_{21} / \omega_1$	$\varphi_{12} - \varphi_{22} / \omega_2$	$\varphi_{13} - \varphi_{23} / \omega_3$			$\varphi_{1n} - \varphi_{2n} / \omega_n$
-----------------	--	--	--	--	--	--

So as to extract the phase information φ out of the two signals S_1 and S_2 , the time domain to frequency domain conversion units 18 and 19 perform complex (real and imaginary) operation.

A second preferred realisation form of the present invention, and especially as concerns realisation of the time delay detection unit 10, shall be explained with the help of fig. 8 and 9.

The output signal of one of the transducers, as shown e.g. of transducer 1, $S_1(t, \omega)$ is fed to a time delay unit 20, wherein, in a first form of this realisation, signal S_1 is time delayed by a predetermined frequency independent time delay τ .



- 15 -

Looking back on fig. 1, signal S_1 accords thus with signal A_1 .

The output signal of time delay unit 20 thus accords with signal A_1' of fig. 1.

The time delay signal according to A_1' is superimposed to the
5 output signal $S_2(t, \omega)$ from transducer 2 at a superimposing unit
23 according to unit 3 of fig. 1, thus resulting in an output
signal according to $A_r(t, \omega)$ of fig. 1. As is known, and as was
explained in connection with fig. 1, the output signal $A_r(t, \omega)$
10 depends from the impinging acoustical signal direction θ ac-
cording to the first order cardoid beam of fig. 2, which card-
oid function nevertheless varies with frequency ω . The output
signal A_r of superimposing unit 23 and e.g. the output signal
 $S_2(t, \omega)$ from transducer 2 are input to a ratio unit 25, as a
comparator unit.

15 For understanding the functioning of ratio unit 25, attention
is drawn to fig. 9. In fig. 9 the cardoid attenuation charac-
teristic of output signal A_r at a specific spectral frequency
 ω_1 is shown. At a specifically considered impinging angle θ_0 ,
the output signal A_r of superimposing unit 23 is $A_{r_0}(\omega_1)$ with an
20 amplitude value as indicated in fig. 9. Simultaneously, at that
frequency ω_1 considered and at that impinging angle θ_0 consid-
ered, the amplitude of signal S_2 is $A_{2_0}(\omega_1)$ as also shown in
fig. 9. It must be emphasised that as the amplitude A_{2_0} varies,
the amplitude of A_{r_0} varies proportionally. Thus, the ratio of
25 A_{r_0} to A_{2_0} according to fig. 9 is indicative of the impinging
angle θ_0 . In the division unit 25 of fig. 8 there is formed for
each spectral component amplitude the ratio of A_r to A_r , where-
from there results a signal spectrum at the output of division
unit 25 with a ratio spectrum. The spectrum of A_{1_0} according to

fig. 6 thus becomes the spectrum of an amplitude ratio which nevertheless is indicative of the impinging angle θ , at which each frequency component of the spectrum of the acoustical signal impinges with respect to the axis a of the two transducers (see fig. 6). In fig. 8 the dotted line block indicates the delay detection unit 10 according to fig. 6. Further signal processing is performed as was explained by means of fig. 6, i.e. via weighing unit 12 and controllable filter unit 14.

In this embodiment it is possible to perform a time domain to frequency domain conversion at the output side of comparator unit 12.

Thus, the output ratio signal of unit 25 is a measure for the time delay dt_0 and is input to the weighting unit 12.

In fig. 10 there is shown the course of the ratio A_r to A_0 as a function of θ at a specific frequency ω_1 .

This amplitude ratio is shown for τ at unit 20 of fig. 8 being selected to be

$$\tau = p/c,$$

wherein p is the distance of the transducers 1 and 2 and c is the velocity of sound.

When selecting τ to be p/c and as may be seen from the cardoid beam function of fig. 2 signal attenuation or dampening for θ near 0° becomes very high.

Thus, in this area of impinging angle θ any kind of noise in A_r according to S_2 of fig. 8 would falsify comparison result



formed at unit 25. This problem can be eliminated by choosing a delay τ which is different, thereby preferably larger than p/c .

In fig. 11 the resulting cardoid diagram is shown for $\tau = 1.2 p/c$, whereas fig. 12 shows in analogy to fig. 10 the course of the amplitude of A_1 divided by the amplitude A_2 .

Further, it must be noted that the cardoid function as shown in the figures 2, 9 and 11 is only valid for one specific frequency considered. In fact, considering different frequencies, the cardoid function varies as shown in fig. 13, wherein the amplitude A_1 of the output signal of superimposing unit 23 according to fig. 8 is shown for $p = 12$ mm, a delay τ of 42 microseconds and for frequencies of 0.5, 1, 2, 4 and 7.2 kHz. From this polar diagram the frequency dependency of the cardoid amplification function is clearly evident. Although such dependency may be neglected in a first approximation, in a preferred form of realising the inventive method principally as shown in fig. 8, such dependency is taken into account. Thus, a preferred realisation form of the fig. 8 technique is shown in fig. 14. Here, the same reference numbers are used as in the figures 7 or 8. The outputs of the transducers 1 and 2 are converted into digital form by respective analogue to digital converters 16, 17 and the resulting digital signal of transducer 1 is time delayed by a time delay τ' , which is larger than p/c . The output signal S_2 of transducer 2 is further converted into frequency domain by a linear (not complex) time to frequency domain conversion unit 18', whereas the output signal A_1 of superimposing unit 23 is converted to frequency domain at a linear time to frequency domain conversion unit 19'. The frequency dependent polar diagram according to fig. 13 is taken into account by a normaliser unit 30 which is in fact a filter. In a

first embodiment the transfer characteristic of the filter is selected proportional to $1/\omega$. This results in a frequency dependency of the pole diagram as is shown in fig. 15 for the same distance and frequency values as shown in fig. 13.

5 As may be seen, a good matching is achieved for small angles θ and frequencies up to about 4 kHz. At 4 kHz the deviation is about 10 %, at $\theta = 0^\circ$.

A further, even improved normalisation function or filter characteristic at unit 30 of fig. 14 is achieved when the filter
10 characteristic is selected as a function $1/\sin(\omega)$. The result is shown in fig. 16. The characteristics match well from 0.5 to 4 kHz. A further advantage of this normalisation technique is improved sensitivity in backwards direction. This improved sensitivity may be exploited for adaptive beam forming, that is
15 for selectively eliminating noise sources from the rear side.

It is evident for the skilled artisan, that such normalisation may be performed also in signal path 1 to 23 and/or 2 to 23.

In this embodiment of fig. 14 it is highly advantageous that only one-dimensional TFC's 18', 19' have to be used and not
20 complex TFC's as in the embodiment of fig. 7.

Fig. 24 shows in block diagram form, that the signal A_0 (dt_0) may also be generated as the output signal of a comparator unit
60 to which on one hand the output signal of an omnidirectional transducer 61, having equal amplification of its acousti-
25 cal/electrical reception characteristic substantially irrespec-

tive of the impinging angle θ and the output signal of a directional transducer 62 with selected, beam shaped reception characteristic are led to.



- 19 -

According to fig. 25 time delaying τ may also be performed by one of the transducers itself.

Thereby, in the embodiment of fig. 25 as well as of fig. 8 τ may be selected to be zero.

5 With the help of fig. 23 a further preferred embodiment, especially of realising the time delay detection unit 10 of fig. 6 shall be explained. The output signals of the transducers 1 and 2 are first converted by respective analogue to digital converters 16 and 17 and then by respective time domain to frequency domain converters 18, 19 finally into frequency domain.
 10 One signal, as an example S_2 , of the converted output signals of the transducers, which, after time to frequency domain conversion may be represented as a spectrum of $S_{2\omega}$ pointers, is converted to its conjugate complex pointers at a conversion
 15 unit 50. At the output of this unit 50, the conjugate complex pointers $S_{2\omega}^*$ are generated. This spectrum S_2^* and the pointer spectrum S_1 are multiplied to form the scalar product spectrum S_3 in a multiplication unit 52. As may be shown, the pointers $S_{3\omega}$ of spectrum S_3 have a phase angle with respect to the real
 20 axis, which is $\Delta\varphi_\omega$.

Thus, the imaginary part of the pointers $S_{3\omega}$ of S_3 become

$$(3) \quad \text{Im} (S_{3\omega}) = |S_{3\omega}| \sin (\Delta\varphi_\omega)$$

with

$$(4) \quad \Delta\varphi_\omega = \omega \cdot (p/c) \cdot \cos(\theta_\omega)$$

According to fig. 23, a conversion unit 53 forms the imaginary part of the pointers $S_{3\omega}$ and a further unit 54 forms the amplitudes $|S_{3\omega}|$ of these pointers.

For small values of $\Delta\phi_\omega$ the sinus in (3) may be approximated by $\Delta\phi_\omega$ itself, so that there results from (3)

$$(3)' \operatorname{Im} (S_{3\omega}) = |S_{1\omega} \cdot S_{2\omega}^*| \omega(p/c) \cdot \cos(\theta_\omega)$$

Thus, and as performed by unit 55, dividing the imaginary parts $\operatorname{Im} (S_{3\omega})$ of the pointers $S_{3\omega}$ of spectrum S_3 by the respective values of the scalar product according to $|S_{3\omega}|$, there results an output signal which accords with $\Delta\phi_\omega$. As was already explained with the help of fig. 7, $\Delta\phi_\omega$ is further divided in unit 56 by the respective pointer frequency ω . The resulting signal is $A_{1\omega}$ according to fig. 6 or $A_{1\omega}'$ according to fig. 7.

All the units 50, 52, 53, 54, 55 and 56 are preferably realised in one calculator unit.

Let's turn back to the generic block diagram of fig. 6 having described different possibilities of realising the delay detector unit 10.

By means of the figs 17 to 22 we will further explain with a specific example the effect of amplitude filter unit 12 and of controllable filter unit 14.

In fig. 17 there are shown examples of two weighing signal characteristics of unit 12. According characteristic I each dt_ω spectral line amplitude of signal $A_{1\omega}$ (see fig. 6) is attenuated to zero, if such amplitude is below or above predetermined

values $dt_{\min, \omega}$, $dt_{\max, \omega}$ and is set to be "one" if such spectral component amplitude is between these two values.

Such selection of weighting function W results in an output signal spectrum A_{12} , as shown in the figures 18a and 18b.

5 The figures 18a and 18b are self-explanatory for the skilled artisan.

Fig. 19 shows a spectrum example of signal S_1 . At the controllable filter unit 14 all spectral lines of S_1 (Fig. b) are amplified by the value 1 according to A_{12} , or are nullified according to zero values of A_{12} . This results, according to fig. 10
15
20, in a spectrum S_r as an output signal spectrum of controllable filter unit 14 of fig. 6. If the weighting function I of fig. 17 is applied to the technique according to fig. 7 there results a beam form as shown in fig. 21 in strong lines. If an amplitude filter characteristic is applied as shown by II in fig. 17, there results the characteristic as shown in fig. 21 in dashed line.

25
30
35
40
45
50
55
60
65
70
75
80
85
90
95
100
105
110
115
120
125
130
135
140
145
150
155
160
165
170
175
180
185
190
195
200
205
210
215
220
225
230
235
240
245
250
255
260
265
270
275
280
285
290
295
300
305
310
315
320
325
330
335
340
345
350
355
360
365
370
375
380
385
390
395
400
405
410
415
420
425
430
435
440
445
450
455
460
465
470
475
480
485
490
495
500
505
510
515
520
525
530
535
540
545
550
555
560
565
570
575
580
585
590
595
600
605
610
615
620
625
630
635
640
645
650
655
660
665
670
675
680
685
690
695
700
705
710
715
720
725
730
735
740
745
750
755
760
765
770
775
780
785
790
795
800
805
810
815
820
825
830
835
840
845
850
855
860
865
870
875
880
885
890
895
900
905
910
915
920
925
930
935
940
945
950
955
960
965
970
975
980
985
990
995
1000
1005
1010
1015
1020
1025
1030
1035
1040
1045
1050
1055
1060
1065
1070
1075
1080
1085
1090
1095
1100
1105
1110
1115
1120
1125
1130
1135
1140
1145
1150
1155
1160
1165
1170
1175
1180
1185
1190
1195
1200
1205
1210
1215
1220
1225
1230
1235
1240
1245
1250
1255
1260
1265
1270
1275
1280
1285
1290
1295
1300
1305
1310
1315
1320
1325
1330
1335
1340
1345
1350
1355
1360
1365
1370
1375
1380
1385
1390
1395
1400
1405
1410
1415
1420
1425
1430
1435
1440
1445
1450
1455
1460
1465
1470
1475
1480
1485
1490
1495
1500
1505
1510
1515
1520
1525
1530
1535
1540
1545
1550
1555
1560
1565
1570
1575
1580
1585
1590
1595
1600
1605
1610
1615
1620
1625
1630
1635
1640
1645
1650
1655
1660
1665
1670
1675
1680
1685
1690
1695
1700
1705
1710
1715
1720
1725
1730
1735
1740
1745
1750
1755
1760
1765
1770
1775
1780
1785
1790
1795
1800
1805
1810
1815
1820
1825
1830
1835
1840
1845
1850
1855
1860
1865
1870
1875
1880
1885
1890
1895
1900
1905
1910
1915
1920
1925
1930
1935
1940
1945
1950
1955
1960
1965
1970
1975
1980
1985
1990
1995
2000
2005
2010
2015
2020
2025
2030
2035
2040
2045
2050
2055
2060
2065
2070
2075
2080
2085
2090
2095
2100
2105
2110
2115
2120
2125
2130
2135
2140
2145
2150
2155
2160
2165
2170
2175
2180
2185
2190
2195
2200
2205
2210
2215
2220
2225
2230
2235
2240
2245
2250
2255
2260
2265
2270
2275
2280
2285
2290
2295
2300
2305
2310
2315
2320
2325
2330
2335
2340
2345
2350
2355
2360
2365
2370
2375
2380
2385
2390
2395
2400
2405
2410
2415
2420
2425
2430
2435
2440
2445
2450
2455
2460
2465
2470
2475
2480
2485
2490
2495
2500
2505
2510
2515
2520
2525
2530
2535
2540
2545
2550
2555
2560
2565
2570
2575
2580
2585
2590
2595
2600
2605
2610
2615
2620
2625
2630
2635
2640
2645
2650
2655
2660
2665
2670
2675
2680
2685
2690
2695
2700
2705
2710
2715
2720
2725
2730
2735
2740
2745
2750
2755
2760
2765
2770
2775
2780
2785
2790
2795
2800
2805
2810
2815
2820
2825
2830
2835
2840
2845
2850
2855
2860
2865
2870
2875
2880
2885
2890
2895
2900
2905
2910
2915
2920
2925
2930
2935
2940
2945
2950
2955
2960
2965
2970
2975
2980
2985
2990
2995
3000
3005
3010
3015
3020
3025
3030
3035
3040
3045
3050
3055
3060
3065
3070
3075
3080
3085
3090
3095
3100
3105
3110
3115
3120
3125
3130
3135
3140
3145
3150
3155
3160
3165
3170
3175
3180
3185
3190
3195
3200
3205
3210
3215
3220
3225
3230
3235
3240
3245
3250
3255
3260
3265
3270
3275
3280
3285
3290
3295
3300
3305
3310
3315
3320
3325
3330
3335
3340
3345
3350
3355
3360
3365
3370
3375
3380
3385
3390
3395
3400
3405
3410
3415
3420
3425
3430
3435
3440
3445
3450
3455
3460
3465
3470
3475
3480
3485
3490
3495
3500
3505
3510
3515
3520
3525
3530
3535
3540
3545
3550
3555
3560
3565
3570
3575
3580
3585
3590
3595
3600
3605
3610
3615
3620
3625
3630
3635
3640
3645
3650
3655
3660
3665
3670
3675
3680
3685
3690
3695
3700
3705
3710
3715
3720
3725
3730
3735
3740
3745
3750
3755
3760
3765
3770
3775
3780
3785
3790
3795
3800
3805
3810
3815
3820
3825
3830
3835
3840
3845
3850
3855
3860
3865
3870
3875
3880
3885
3890
3895
3900
3905
3910
3915
3920
3925
3930
3935
3940
3945
3950
3955
3960
3965
3970
3975
3980
3985
3990
3995
4000
4005
4010
4015
4020
4025
4030
4035
4040
4045
4050
4055
4060
4065
4070
4075
4080
4085
4090
4095
4100
4105
4110
4115
4120
4125
4130
4135
4140
4145
4150
4155
4160
4165
4170
4175
4180
4185
4190
4195
4200
4205
4210
4215
4220
4225
4230
4235
4240
4245
4250
4255
4260
4265
4270
4275
4280
4285
4290
4295
4300
4305
4310
4315
4320
4325
4330
4335
4340
4345
4350
4355
4360
4365
4370
4375
4380
4385
4390
4395
4400
4405
4410
4415
4420
4425
4430
4435
4440
4445
4450
4455
4460
4465
4470
4475
4480
4485
4490
4495
4500
4505
4510
4515
4520
4525
4530
4535
4540
4545
4550
4555
4560
4565
4570
4575
4580
4585
4590
4595
4600
4605
4610
4615
4620
4625
4630
4635
4640
4645
4650
4655
4660
4665
4670
4675
4680
4685
4690
4695
4700
4705
4710
4715
4720
4725
4730
4735
4740
4745
4750
4755
4760
4765
4770
4775
4780
4785
4790
4795
4800
4805
4810
4815
4820
4825
4830
4835
4840
4845
4850
4855
4860
4865
4870
4875
4880
4885
4890
4895
4900
4905
4910
4915
4920
4925
4930
4935
4940
4945
4950
4955
4960
4965
4970
4975
4980
4985
4990
4995
5000
5005
5010
5015
5020
5025
5030
5035
5040
5045
5050
5055
5060
5065
5070
5075
5080
5085
5090
5095
5100
5105
5110
5115
5120
5125
5130
5135
5140
5145
5150
5155
5160
5165
5170
5175
5180
5185
5190
5195
5200
5205
5210
5215
5220
5225
5230
5235
5240
5245
5250
5255
5260
5265
5270
5275
5280
5285
5290
5295
5300
5305
5310
5315
5320
5325
5330
5335
5340
5345
5350
5355
5360
5365
5370
5375
5380
5385
5390
5395
5400
5405
5410
5415
5420
5425
5430
5435
5440
5445
5450
5455
5460
5465
5470
5475
5480
5485
5490
5495
5500
5505
5510
5515
5520
5525
5530
5535
5540
5545
5550
5555
5560
5565
5570
5575
5580
5585
5590
5595
5600
5605
5610
5615
5620
5625
5630
5635
5640
5645
5650
5655
5660
5665
5670
5675
5680
5685
5690
5695
5700
5705
5710
5715
5720
5725
5730
5735
5740
5745
5750
5755
5760
5765
5770
5775
5780
5785
5790
5795
5800
5805
5810
5815
5820
5825
5830
5835
5840
5845
5850
5855
5860
5865
5870
5875
5880
5885
5890
5895
5900
5905
5910
5915
5920
5925
5930
5935
5940
5945
5950
5955
5960
5965
5970
5975
5980
5985
5990
5995
6000
6005
6010
6015
6020
6025
6030
6035
6040
6045
6050
6055
6060
6065
6070
6075
6080
6085
6090
6095
6100
6105
6110
6115
6120
6125
6130
6135
6140
6145
6150
6155
6160
6165
6170
6175
6180
6185
6190
6195
6200
6205
6210
6215
6220
6225
6230
6235
6240
6245
6250
6255
6260
6265
6270
6275
6280
6285
6290
6295
6300
6305
6310
6315
6320
6325
6330
6335
6340
6345
6350
6355
6360
6365
6370
6375
6380
6385
6390
6395
6400
6405
6410
6415
6420
6425
6430
6435
6440
6445
6450
6455
6460
6465
6470
6475
6480
6485
6490
6495
6500
6505
6510
6515
6520
6525
6530
6535
6540
6545
6550
6555
6560
6565
6570
6575
6580
6585
6590
6595
6600
6605
6610
6615
6620
6625
6630
6635
6640
6645
6650
6655
6660
6665
6670
6675
6680
6685
6690
6695
6700
6705
6710
6715
6720
6725
6730
6735
6740
6745
6750
6755
6760
6765
6770
6775
6780
6785
6790
6795
6800
6805
6810
6815
6820
6825
6830
6835
6840
6845
6850
6855
6860
6865
6870
6875
6880
6885
6890
6895
6900
6905
6910
6915
6920
6925
6930
6935
6940
6945
6950
6955
6960
6965
6970
6975
6980
6985
6990
6995
7000
7005
7010
7015
7020
7025
7030
7035
7040
7045
7050
7055
7060
7065
7070
7075
7080
7085
7090
7095
7100
7105
7110
7115
7120
7125
7130
7135
7140
7145
7150
7155
7160
7165
7170
7175
7180
7185
7190
7195
7200
7205
7210
7215
7220
7225
7230
7235
7240
7245
7250
7255
7260
7265
7270
7275
7280
7285
7290
7295
7300
7305
7310
7315
7320
7325
7330
7335
7340
7345
7350
7355
7360
7365
7370
7375
7380
7385
7390
7395
7400
7405
7410
7415
7420
7425
7430
7435
7440
7445
7450
7455
7460
7465
7470
7475
7480
7485
7490
7495
7500
7505
7510
7515
7520
7525
7530
7535
7540
7545
7550
7555
7560
7565
7570
7575
7580
7585
7590
7595
7600
7605
7610
7615
7620
7625
7630
7635
7640
7645
7650
7655
7660
7665
7670
7675
7680
7685
7690
7695
7700
7705
7710
7715
7720
7725
7730
7735
7740
7745
7750
7755
7760
7765
7770
7775
7780
7785
7790
7795
7800
7805
7810
7815
7820
7825
7830
7835
7840
7845
7850
7855
7860
7865
7870
7875
7880
7885
7890
7895
7900
7905
7910
7915
7920
7925
7930
7935
7940
7945
7950
7955
7960
7965
7970
7975
7980
7985
7990
7995
8000
8005
8010
8015
8020
8025
8030
8035
8040
8045
8050
8055
8060
8065
8070
8075
8080
8085
8090
8095
8100
8105
8110
8115
8120
8125
8130
8135
8140
8145
8150
8155
8160
8165
8170
8175
8180
8185
8190
8195
8200
8205
8210
8215
8220
8225
8230
8235
8240
8245
8250
8255
8260
8265
8270
8275
8280
8285
8290
8295
8300
8305
8310
8315
8320
8325
8330
8335
8340
8345
8350
8355
8360
8365
8370
8375
8380
8385
8390
8395
8400
8405
8410
8415
8420
8425
8430
8435
8440
8445
8450
8455
8460
8465
8470
8475
8480
8485
8490
8495
8500
8505
8510
8515
8520
8525
8530
8535
8540
8545
8550
8555
8560
8565
8570
8575
8580
8585
8590
8595
8600
8605
8610
8615
8620
8625
8630
8635
8640
8645
8650
8655
8660
8665
8670
8675
8680
8685
8690
8695
8700
8705
8710
8715
8720
8725
8730
8735
8740
8745
8750
8755
8760
8765
8770
8775
8780
8785
8790
8795
8800
8805
8810
8815
8820
8825
8830
8835
8840
8845
8850
8855
8860
8865
8870
8875
8880
8885
8890
8895
8900
8905
8910
8915
8920
8925
8930
8935
8940
8945
8950
8955
8960
8965
8970
8975
8980
8985
8990
8995
9000
9005
9010
9015
9020
9025
9030
9035
9040
9045
9050
9055
9060
9065
9070
9075
9080
9085
9090
9095
9100
9105
9110
9115
9120
9125
9130
9135
9140
9145
9150
9155
9160
9165
9170
9175
9180
9185
9190
9195
9200
9205
9210
9215
9220
9225
9230
9235
9240
9245
9250
9255
9260
9265
9270
9275
9280
9285
9290
9295
9300
9305
9310
9315
9320
9325
9330
9335
9340
9345
9350
9355
9360
9365
9370
9375
9380
9385
9390
9395
9400
9405
9410
9415
9420
9425
9430
9435
9440
9445
9450
9455
9460
9465
9470
9475
9480
9485
9490
9495
9500
9505
9510
9515
9520
9525
9530
9535
9540
9545
9550
9555
9560
9565
9570
9575
9580
9585
9590
9595
9600
9605
9610
9615
9620
9625
9630
9635
9640
9645
9650
9655
9660
9665
9670
9675
9680
9685
9690
9695
9700
9705
9710
9715
9720
9725
9730
9735
9740
9745
9750
9755
9760
9765
9770
9775
9780
9785
9790
9795
9800
9805
9810
9815
9820
9825
9830
9835
9840
9845
9850
9855
9860
9865
9870
9875
9880
9885
9890
9895
9900
9905
9910
9915
9920
9925
9930
9935
9940
9945
9950
9955
9960
9965
9970
9975
9980
9985
9990
9995
10000
10005
10010
10015
10020
10025
10030
10035
10040
10045
10050
10055
10060
10065
10070
10075
1

tional. Beam forming following the inventive principle can also be made by the combination of the functions of two or more microphones. As is perfectly clear to the skilled artisan also the delay detector can be realised in many other ways. Further, normalisation, which was explained with the help of normaliser unit 30 in fig. 14, may clearly be done by providing time domain to frequency domain conversion just after the analogue to digital converters 16 and 17 and providing frequency-specific arrays or tables of time delays τ_n .

10 It is to be understood that, if any prior art publication is referred to herein, such reference does not constitute an admission that the publication forms a part of the common general knowledge in the art, in Australia or in any other country.

For the purposes of this specification it will be clearly understood that the word "comprising" means "including but not limited to", and that the word "comprises" has a corresponding meaning.

5
10
15
20
25
30
35
40
45
50
55
60
65
70
75
80
85
90
95
100



THE CLAIMS DEFINING THE INVENTION ARE AS FOLLOWS:

1. A method for electronically forming a predetermined characteristic of amplification in dependency of direction from which acoustical signals are received at at least two spaced apart acoustical/electrical transducers, comprising, at least within a predetermined frequency band, the steps of:
- 5
- 10 - repetitively determining from signals dependent from said acoustical signals a respective mutual delay signal according to reception delay at said at least two transducers;
 - 15 - subjecting a signal dependent from the output signal of at least one of said at least two transducers to filtering with a filtering transfer characteristic;
 - controlling said filtering transfer characteristic in dependency of said mutual delay signal;
 - 20 - exploiting a signal dependent from the output signal of said filtering as electrical reception signal.
- 25 2. The method of claim 1, further comprising the step of determining said mutual delay signal as a spectral signal.
- 30 3. The method of claim 1 or 2, further comprising the step of performing said repetitive determining from said signals converted into frequency domain.



4. The method of one of claims 1 to 3, comprising the step of
subjecting said signal dependent from the output signal to
said filtering converted into frequency domain.

5. The method of claim 4, further comprising the step of re-
5 converting said signal exploited into time domain.

6. The method of one of claims 1 to 5, further comprising the
step of performing said determining by monitoring phase differ-
ence of spectral components of said signals and dividing said
phase difference monitored by the frequency of said respective
10 spectral components.

7. The method of one of claims 1 to 5, thereby performing
said determining by

- providing one of said at least two transducers with an at
least approximately omnidirectional acoustical to electrical
reception characteristic;
15

- providing one of said at least two transducers with a direc-
tional, beam-shaped acoustical to electrical reception char-
acteristic;

- comparing signals dependent from the output signals of said
at least two transducers and exploiting the result signal of
said comparing as said mutual delay signal.
20

8. The method of one claims 1 to 5, further comprising the
step of performing said determining by

- superimposing signals dependent from the output signals of
25 said at least two transducers and



- 25 -

- comparing the result signal of said superimposing and at least one of said dependent signals.

9. The method of claim 8, further comprising the step of delaying one of said dependent signals before said superimposing
5 by a predetermined or frequency dependent time amount.

10. The method of one of claims 1 to 5, further comprising the step of performing said determining by

- converting signals dependent from the output signals of said at least two transducers into frequency domain;

10 - forming the conjugate complex pointers of one of said signals converted;

- multiplying the pointers of the other of said signals converted with said conjugate complex pointers to get multiplication result pointers;

15 - forming the amplitudes of said multiplication result pointers;

- forming the imaginary pointers components of said multiplication result pointers;

20 - forming the ratio of said imaginary pointer components and said amplitudes multiplied by the respective frequency,

the result signal of said ratio forming being said respective control delay signal in spectral representation.

11. The method of claim 9, further comprising the step of performing said delaying with a time delay which is different
25 from, preferably larger than the quotient of the mutual dis-

tance of said at least two transducers and velocity of sound.

12. The method of one of claims 7 to 9 or 11, further
5 comprising the step of normalising at least one of the
comparing result signal, of the superimposing result
signal and of at least one of said dependent signals with
a frequency dependent normalising function.

10 13. The method of one of claims 7 to 9, 11 or 12,
further comprising the step of performing said comparing
by spectrally forming the ratio of amplitudes of the
superimposing result signal and of at least one of said
dependent signals.

15 14. The method of one of claim 1 to 13, further
comprising the step of controlling said transfer
characteristic by subjecting said delay spectral signal to
weighting and controlling said transfer characteristic by
20 the result of said weighting.

15 15. The method of claim 14, further comprising the
step of adjusting said predetermined characteristic of
amplification by adjusting a weighting characteristic for
said weighting.

16. An acoustical sensor apparatus comprising
- at least two acoustical/electrical transducers at a
30 predetermined mutual distance;
- a time delay detection unit with at least two inputs and
an output, the inputs thereof being respectively
operationally connected to the outputs of said at least
35 two transducers, said time delay detection unit
generating an output signal in dependency of the time
delay of acoustical signals impinging on said at least



two transducers;

- a weighting unit with predetermined weighting characteristic and with an input and with an output, the input thereof being operationally connected to the output of said time delay detection unit;
- a filter unit with a controllable transfer characteristic and with at least one input, a characteristic control input and an output, the input thereof being operationally connected to the output of at least one of said at least two transducers, the control input thereof being operationally connected to the output of said weighting unit, the filter unit generating an output signal in dependency of its input signal and said characteristic controlled by the signal applied at said control input, being dependent from said output signal of said delay detection unit converted by said weighting characteristic of said weighting unit.

17. The apparatus of claim 16, said control input of said filter unit receiving said output signal of said weighting unit in frequency domain.

18. The apparatus of one of claims 16 or 17, further comprising time domain to frequency converters interconnected between said at least two transducers and said time delay detection unit, said detection unit being a spectral time delay detection unit.

19. The apparatus of one of claims 16 to 18, wherein one of said at least two transducers is a transducer with at least approximately an omnidirectional acoustical/electrical reception characteristic on said time delay detection unit comprises a comparator unit, the inputs thereof being operationally connected to the outputs of said at least two transducers, the output of



said comparator unit being operationally connected to the input of said time delay detection unit.

5 20. The apparatus of one of claims 16 to 18, said time delay detection unit comprising a superimposing unit, the inputs thereof being operationally connected to the outputs of said at least two transducers, the output being operationally connected to the output of said time delay detection unit.

10 21. The apparatus of claim 20, wherein said time delay detection unit comprises a time delay unit with an input operationally connected to the output of one of said transducers and with an output operationally connected to one input of said superimposing unit, the second input of said superimposing unit being operationally connected to the output of the second of said at least two transducers.

15 22. The apparatus of claim 21, wherein the output of said superimposing unit being operationally connected to one input of a comparator unit, the second input thereof being operationally connected to said output of said second transducer;

20 23. the output of said comparator unit being the output of said spectral delay detector unit.

25 24. The apparatus of one of claims 21 or 22, wherein said time delay unit performs signal delaying by an amount which is different than given by the mutual distance of said transducers divided by velocity of sound, which is preferably larger.

30 25. The apparatus of one of the claims 16 to 23, wherein said time delay detection unit comprises a normalising filter unit with predetermined transfer characteristic, which is provided at its input and/or



output.

25. The apparatus of one of claims 20 to 24, wherein
said comparator unit is a ratio forming unit of amplitudes
5 of respective frequency components applied to its inputs.

26. The apparatus of claim 16, wherein said time
delay detection unit is a spectral time delay detection
unit and performs spectral phase difference measurement
10 and division of spectral phase difference by the
respective frequency.

27. The apparatus of claim 26, wherein said time
delay detection unit comprises a calculator unit with two
15 inputs operationally connected to the outputs of said at
least two transducers which

- forms the conjugate complex pointers of a signal at one
of its inputs;
- 20 - multiplies said conjugate complex pointers with the
respective pointers of the signal applied to its second
input;
- 25 - divides the imaginary part of multiplying result
pointers by the amplitude of said multiplying result
pointers;
- further divides the dividing result pointers by their
30 respective frequency and emits as an output signal at
its output the result pointers of said further dividing.

28. The apparatus of claim 16, further comprising a
time to frequency domain conversion unit interconnected
35 between at least one of said outputs of said at least two
acoustical/electrical transducers and said filter unit.



29. The apparatus of claim 20, further comprising a time to frequency domain conversion unit interconnected between the output of said superimposing unit and control input of said frequency filter unit.

5

30. The apparatus of one of claims 16 to 29, being a hearing aid apparatus, the mutual distance of said at least two transducers being 4 cm at most, preferably 0,5 cm to 1,5 cm.

10

31. The apparatus of one of claims 16 to 30, said weighting unit comprising a control input to adjust weighting characteristic of said weighting unit.

15

32. A method for electronically forming a predetermined characteristic of amplification, substantially as herein described with reference to the accompanying figures 6-25.

20

33. An acoustical sensor apparatus, substantially as herein described with reference to the accompanying figures 6-25.

25

Dated this 15th day of February 2002

PHONAK AG

By their Patent Attorneys

GRIFFITH HACK

Fellows Institute of Patent and

30

Trade Mark Attorneys of Australia



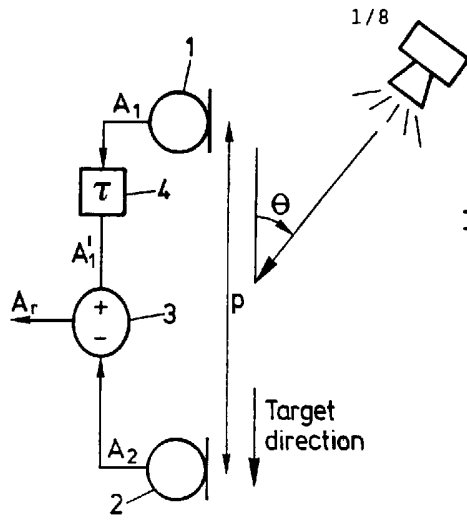

FIG.1

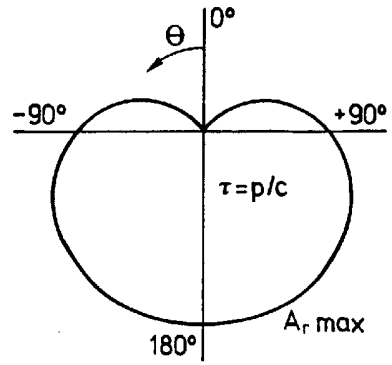

FIG.2

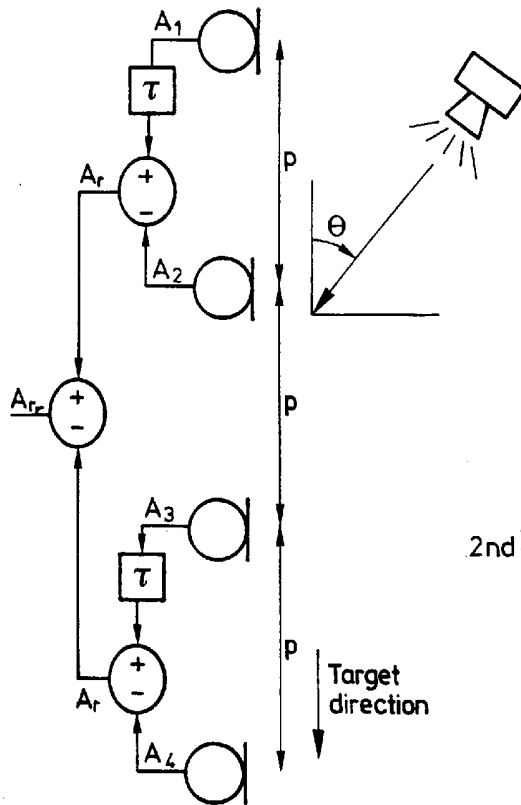

FIG.3

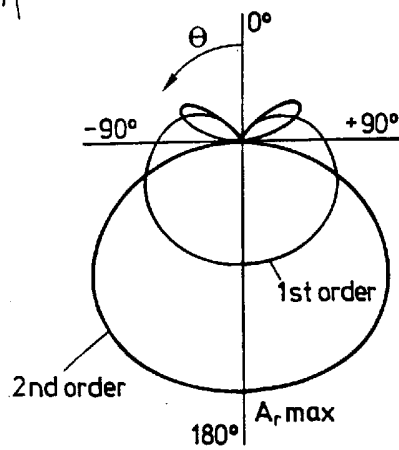
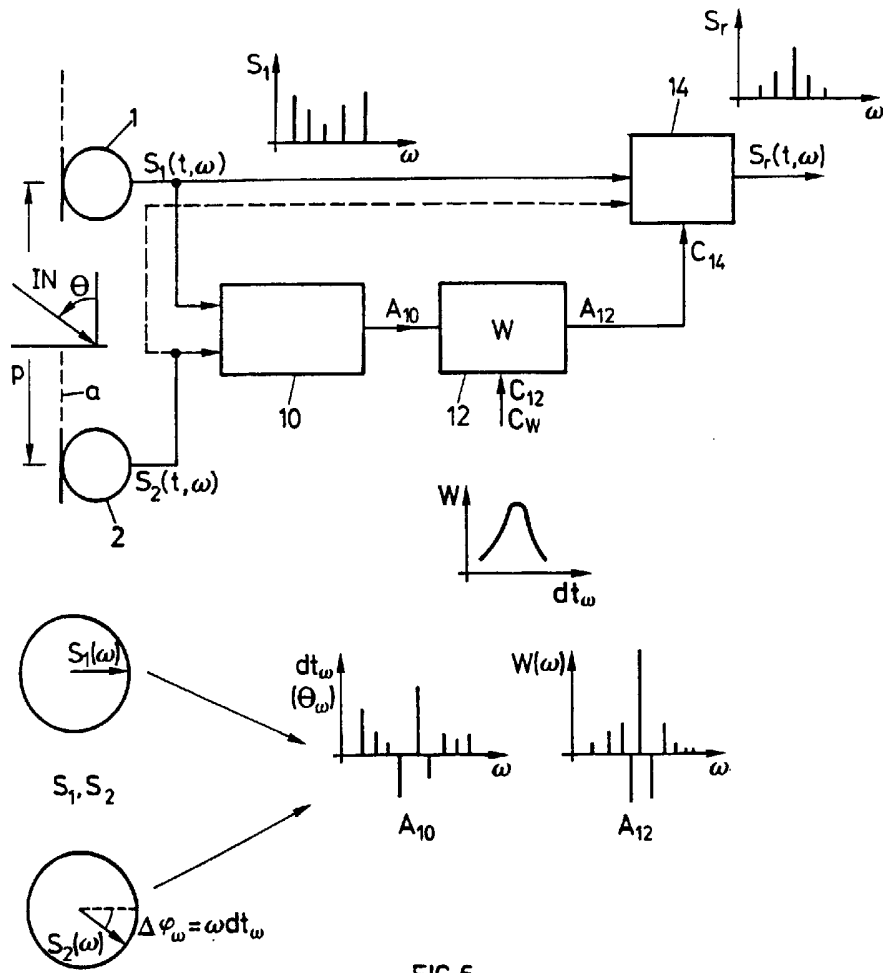
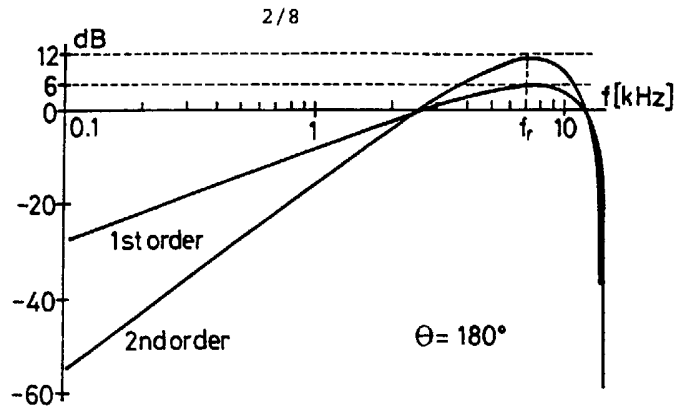

FIG.4



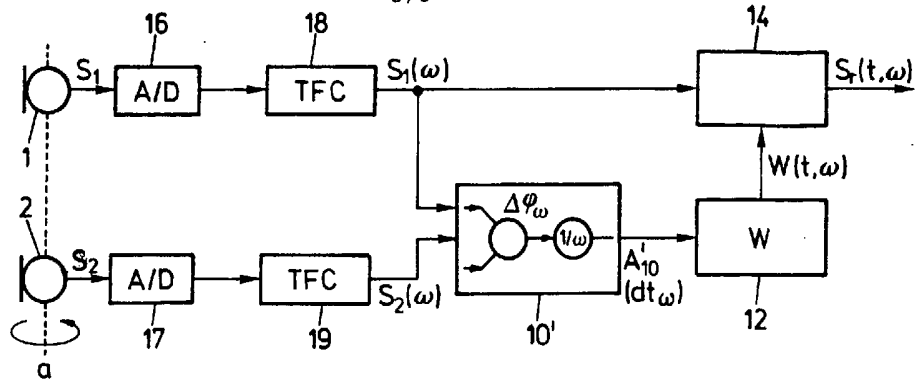

FIG.7

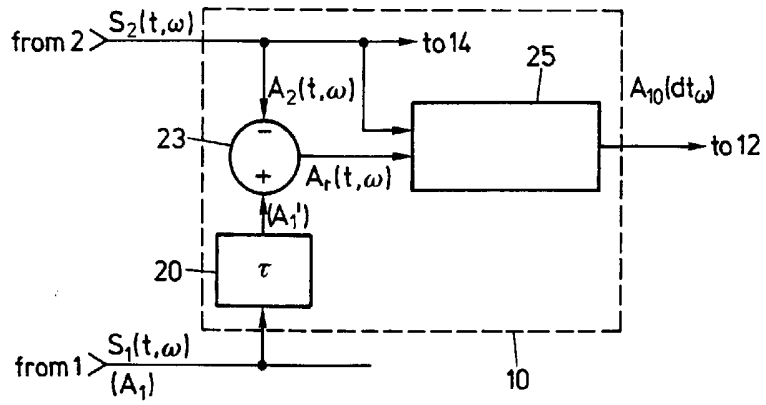

FIG.8

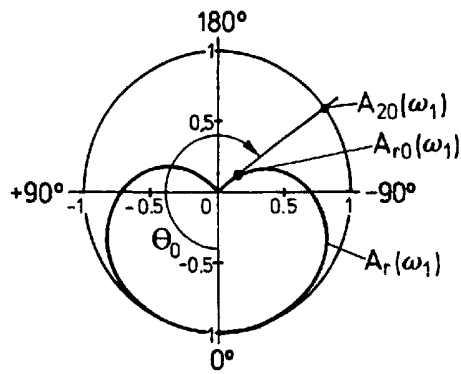

FIG.9

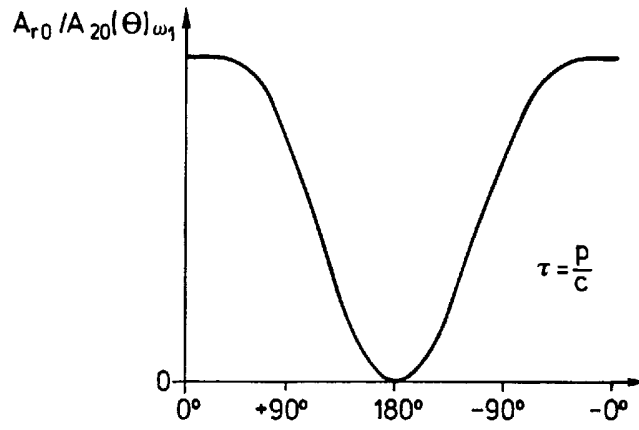

FIG. 10

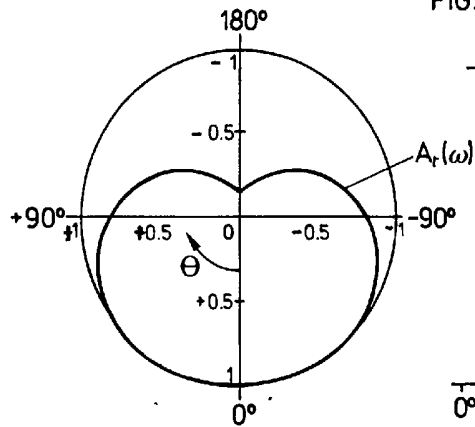

FIG. 11

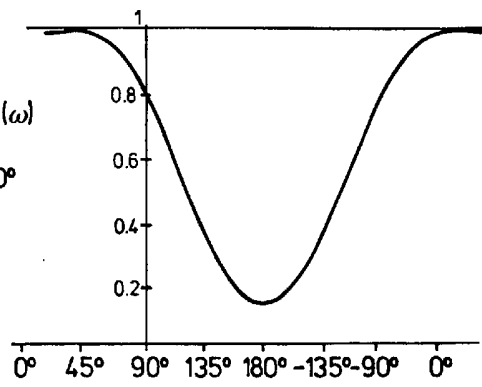

FIG. 12

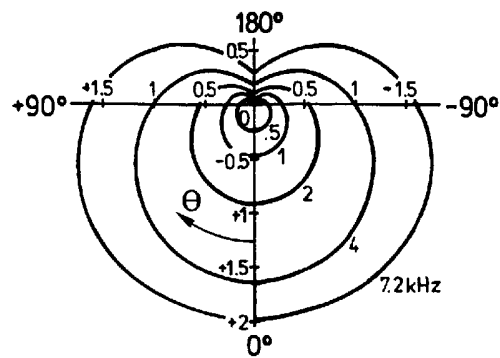

FIG. 13

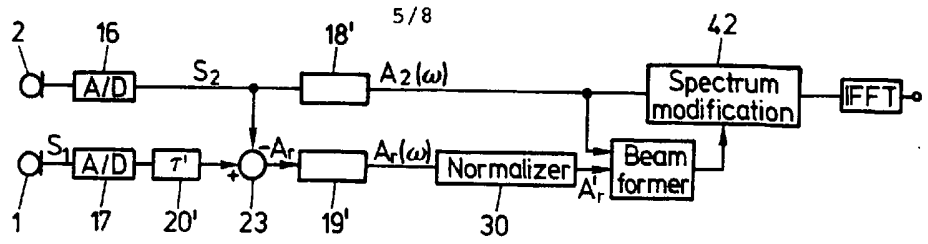

FIG. 14

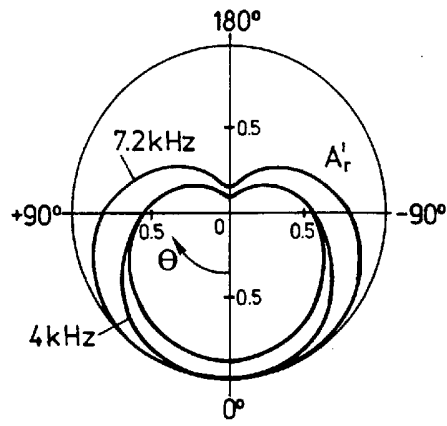

FIG. 15

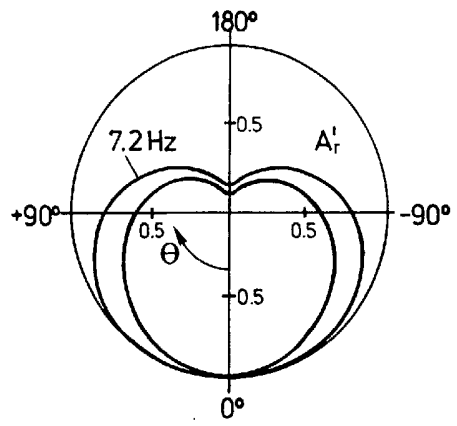

FIG. 16

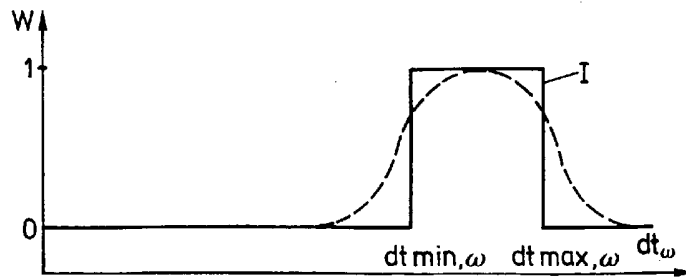
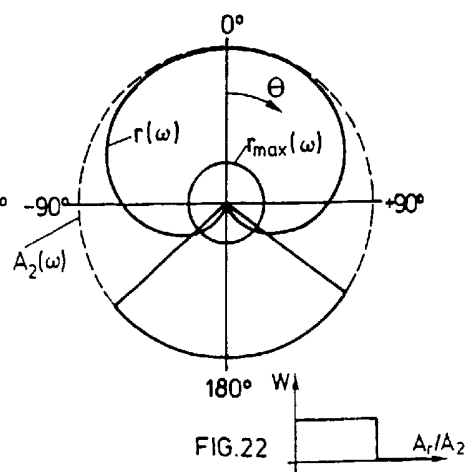
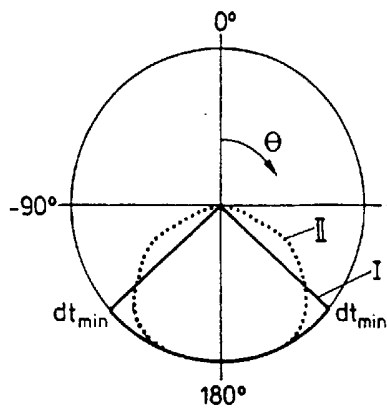
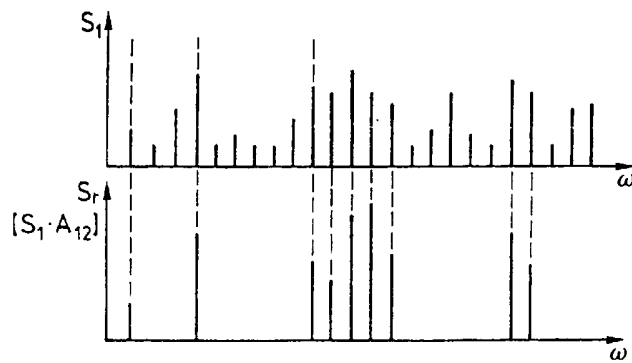
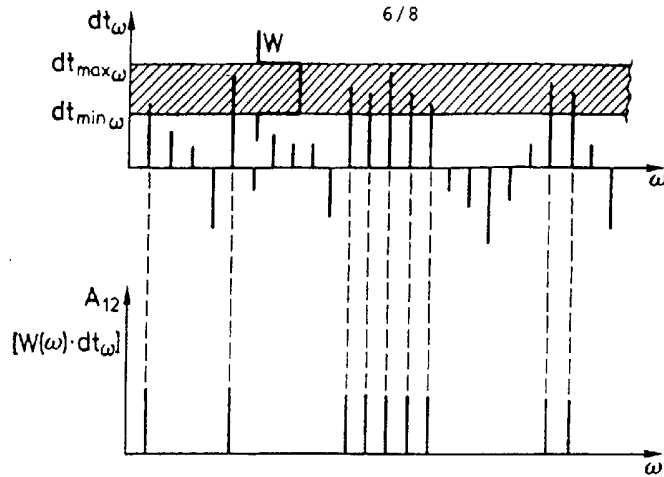

FIG. 17



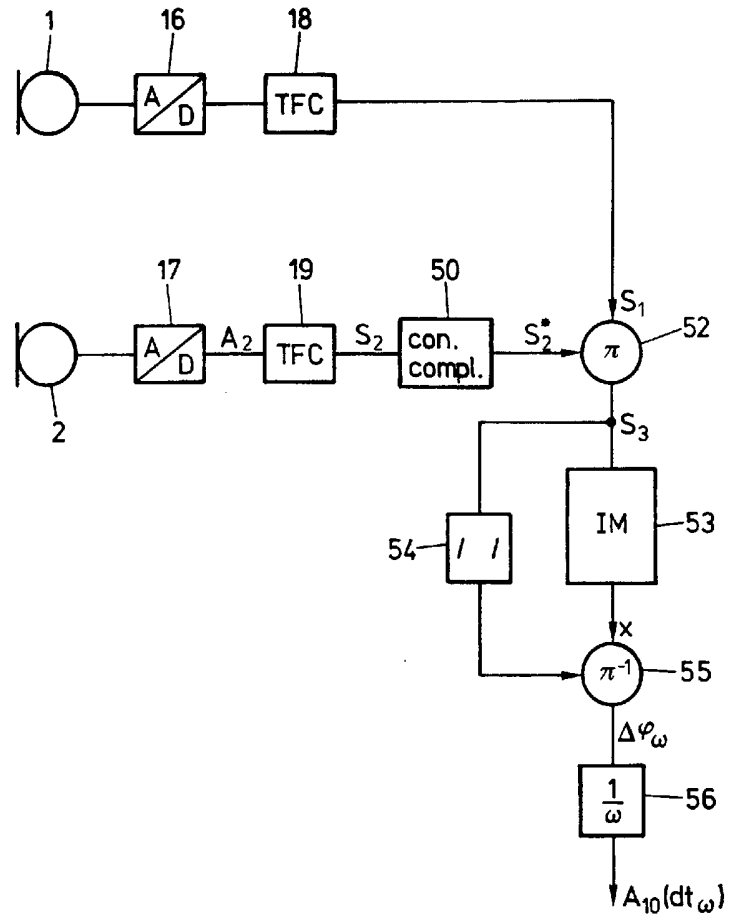

FIG. 23

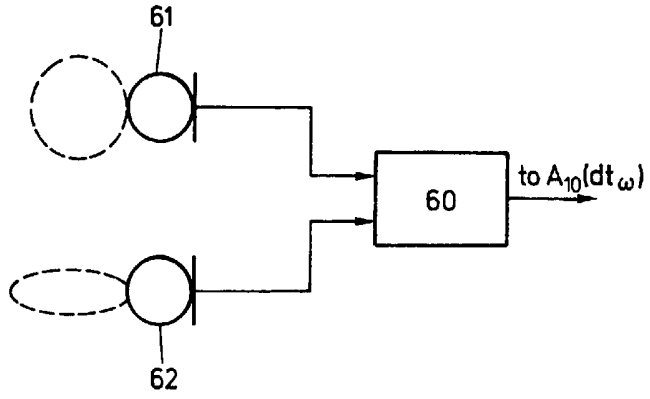

FIG. 24

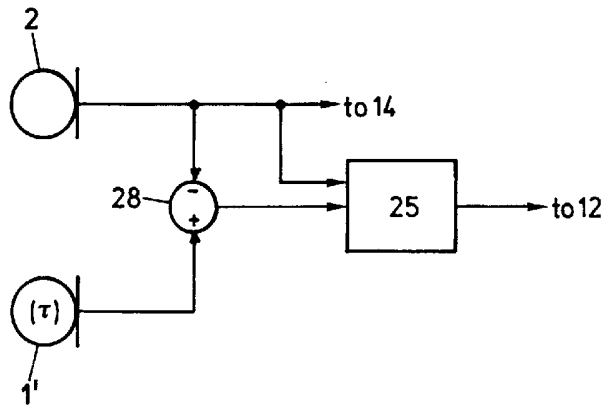

FIG. 25