

(51) International Patent Classification⁵ :
A61B 17/00

A1

(11) International Publication Number: WO 96/06565

(43) International Publication Date: 7 March 1996 (07.03.96)

(21) International Application Number: PCT/US94/09631

(22) International Filing Date: 29 August 1994 (29.08.94)

(71)(72) Applicant and Inventor: RUFF, Gregory, L. [US/US];
201 Longwood, Chapel Hill, NC 27514 (US).

(74) Agents: EVANS, Richard, W. et al.; Moore & Van Allen, Suite
800, 2200 W. Main Street, Durham, NC 27705 (US).

(81) Designated States: CA, GB, JP, European patent (AT, BE, CH,
DE, DK, ES, FR, GB, GR, IE, IT, LU, MC, NL, PT, SE).

Published

With international search report.

(54) Title: BARBED TISSUE CONNECTOR AND INSERTING DEVICE

(57) Abstract

A barbed tissue connector (2) and insertion device (80) are disclosed for use in closing a body wound. The connector (2) includes an elongated body (4) and a pointed end (9) to facilitate insertion of the connector into tissue. A plurality of closely spaced barbs (6) are disposed on the body from the pointed end of the connector (9) to a predetermined location on the body. The barbs (6) are yieldable toward the body to make it easier to insert the connector (2) in tissue, and the barbs (6) are generally rigid in an opposite direction to hold the connector (2) in the tissue. The connector (2) can be manually inserted into the tissue of a patient, or the connector (2) can be inserted by means of an inserting device (80). The inserting device comprises a tubular body (82) which is adapted to receive the connector (2) therein with the pointed leading end of the connector (9) protruding from an open leading end (84) of the tubular body (82). The inserting device (80) and the connector (2) contained therein are positioned in tissue such that at least one of the barbs (6) on the connector (2) is engaging tissue, and the device (80) is then retracted from the tissue, leaving the connector (2) in place.

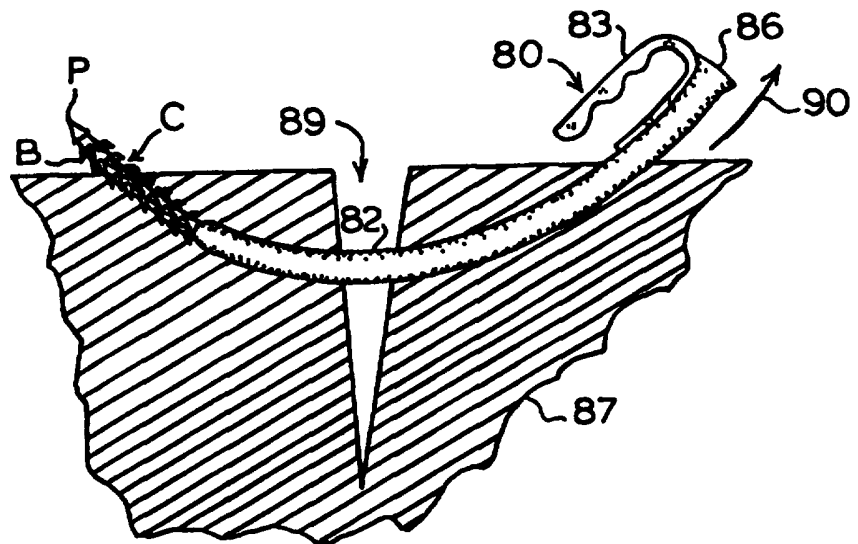

The inserting device (80) and the connector (2) contained therein are positioned in tissue such that at least one of the barbs (6) on the connector (2) is engaging tissue, and the device (80) is then retracted from the tissue, leaving the connector (2) in place.

FOR THE PURPOSES OF INFORMATION ONLY

Codes used to identify States party to the PCT on the front pages of pamphlets publishing international applications under the PCT.

AT	Austria	GB	United Kingdom	MR	Mauritania
AU	Australia	GE	Georgia	MW	Malawi
BB	Barbados	GN	Guinea	NE	Niger
BE	Belgium	GR	Greece	NL	Netherlands
BF	Burkina Faso	HU	Hungary	NO	Norway
BG	Bulgaria	IE	Ireland	NZ	New Zealand
BJ	Benin	IT	Italy	PL	Poland
BR	Brazil	JP	Japan	PT	Portugal
BY	Belarus	KE	Kenya	RO	Romania
CA	Canada	KG	Kyrgystan	RU	Russian Federation
CF	Central African Republic	KP	Democratic People's Republic of Korea	SD	Sudan
CG	Congo	KR	Republic of Korea	SE	Sweden
CH	Switzerland	KZ	Kazakhstan	SI	Slovenia
CI	Côte d'Ivoire	LI	Liechtenstein	SK	Slovakia
CM	Cameroon	LK	Sri Lanka	SN	Senegal
CN	China	LU	Luxembourg	TD	Chad
CS	Czechoslovakia	LV	Latvia	TG	Togo
CZ	Czech Republic	MC	Monaco	TJ	Tajikistan
DE	Germany	MD	Republic of Moldova	TT	Trinidad and Tobago
DK	Denmark	MG	Madagascar	UA	Ukraine
ES	Spain	ML	Mali	US	United States of America
FI	Finland	MN	Mongolia	UZ	Uzbekistan
FR	France			VN	Viet Nam
GA	Gabon				

Barbed Tissue Connector and Inserting Device

BACKGROUND OF THE INVENTION

1. Field of the Invention

This invention relates to a barbed tissue connector including an inserting device for the barbed tissue connector, and more particularly, to a barbed tissue connector and inserting device which can be used to quickly and effectively close a body wound.

2. Description of the Prior Art

Human wounds are typically repaired with a filament introduced into the tissue by a needle attached to one end. After piercing the opposing faces of the wound, the needle is removed, and the ends of the suture are tied together with at least three overhand knots. Such a technique requires considerable time and expertise on the part of the surgeon. There are also a number of other drawbacks to repairing a wound in this manner. For example, it is very difficult to use sutures to repair wounds where there is insufficient space to properly manipulate the suture, especially those wounds repaired using fiber optic visualization. The suture forms a loop as it is tied, and this loop constricts blood flow to the tissue in its confines, promoting necrosis of the wound margins. Further, if the needle's passage was noncircular, the tissue will be distorted as it is secured by the suture.

Alternatives to conventional sutures are known in the prior art. Staples, as shown, for example, in U.S. Pat. No. 4,994,073, to Green, are often used for approximating the superficial layer of the wound. Staples, however, are generally unsuitable for deeper layers of tissue.

The patent to Alcamo, U.S. Pat. No. 3,123,077, discloses a roughened suture which can be passed through tissue in one direction, but resists movement in the opposite direction. The Alcamo suture, however, still must be sewn, as by a conventional technique, and the trailing end must be secured with knots. Thus, although there is less slippage of the suture in the wound, most of the disadvantages of sutures noted above are also found in the Alcamo suture.

The patent to Tanner, U.S. Pat. No. 3,716,058, discloses a relatively rigid suture with one or more barbs on opposite ends of an arcuate body. The suture is inserted by means of a notched and slotted needle. One disadvantage of the Tanner suture is that the rigid barbs, which protrude from the needle as the suture is inserted, will lacerate tissue and prevent retrograde repositioning. Further, since the barbs are only placed at the ends of the suture, the forces applied to the tissue by the barbs will be limited to a relatively small area; this substantially increases the pressure on the blood vessels ensnared by a barb and severely restricts blood flow to the area.

It will be seen from the foregoing that there is a need for a tissue connector which can be placed more expeditiously than sutures, is self-retaining, obviates distortion of the tissue, can close tissue inaccessible to conventional procedures, and

which preserves blood flow by broadly distributing the retention force.

SUMMARY OF THE INVENTION

It is an object of the present invention to overcome the aforementioned problems in the prior art and to provide an improved tissue connector and inserting device for use with the tissue connector.

In accordance with the present invention there is provided a barbed tissue connector and an inserting device for use with the connector, the connector comprising: an elongated body having a point formed on one end, the body being formed of a material sufficiently hard for the point to pierce tissue and enable the connector to be inserted in tissue when a substantially axial force is applied to the body; and a plurality of barbs projecting from the body, the barbs being disposed around the periphery of the body along a length of the body which extends from adjacent the one end to a predetermined location on the body, the barbs being configured such that they are yieldable in a direction toward the body and are generally rigid in an opposite direction, and the barbs being sufficiently resilient to return to a predetermined position after deflection therefrom.

The inserting device for use with the barbed tissue connector, comprises: a tubular body having an interior of a size sufficient to receive a barbed tissue connector, the tubular body having a leading end having an opening therein and a trailing end having an opening therein, and the opening in the leading end being sufficiently large to permit the connector to be extracted therefrom.

In one embodiment of the present invention, the barbed tissue connector includes an elongated body and a plurality of barbs which are disposed in a helical pattern on the body and extend from a pointed end of the connector to a predetermined location on the body. Each barb includes a first side, which forms an obtuse angle with the body, and a second side which forms an acute angle with the body. The body is substantially rigid and sufficiently resilient to return to a predetermined position after deflection therefrom. When the connector is inserted in tissue to repair a wound, the pointed end pierces tissue and the barbs yield toward the body to facilitate entry of the connector.

In another embodiment of the present invention, the inserting device for the barbed tissue connector comprises a tubular body which is adapted to receive a barbed tissue connector therein with a pointed end of the connector protruding from an open leading end of the tubular body. The inserting device and the connector contained therein are positioned in tissue such that at least one of the barbs on the connector is engaging tissue, and the device is then retracted from the tissue, leaving the connector in place.

When the connector has been placed in a desired position in tissue, the barbs strongly resist movement away from this position. The connector can be inserted by gripping the connector in the hand and pushing the connector into the tissue, or the connector can be inserted by means of the inserting device which is withdrawn when the connector is in place.

A principal advantage of the barbed tissue connector of the present invention is that it permits a surgeon to rapidly and securely attach the edges of a wound in human tissue without the

necessity for threading and tying numerous individual stitches or for the use of a complicated or elaborate tool to insert the connector. The connector and inserting device are configured to minimize distortion and damage to tissue when inserted, and to minimize scarring or tissue necrosis across the wound. The connector is capable of insertion into the faces of a wound, can connect tissue at the bottom of a deep wound, and can be used to connect tissue which is inaccessible to a staple. Finally, the connector of the present invention can be used by a surgeon to quickly and accurately insert a connector, with or without the inserting device, who only has access to tissue from a small opening or from only one direction, as, for example, during an endoscopic procedure.

Other features and advantages will become apparent upon reference to the following description of the preferred embodiment when read in light of the attached drawings.

BRIEF DESCRIPTION OF THE DRAWINGS

Fig. 1 is a side view of one embodiment of a barbed tissue connector of the present invention, with a section of the connector broken away to more clearly show the arrangement of the barbs;

Fig. 2 is an end view of the connector shown in Fig. 1;

Fig. 3 is a side view of another embodiment of a connector of the present invention, with a section of the connector broken away;

Fig. 4 is a side view of another embodiment of a connector of the present invention;

Fig. 5 is a side view of another embodiment of a connector of the present invention;

Fig. 6 is a side view of another embodiment of a connector of the present invention;

Fig. 7 is a sectional view taken along the line 7-7 in Fig. 6;

Fig. 8 is a side view of another embodiment of a connector of the present invention;

Fig. 9 is a sectional view taken along the line 9-9 in Fig. 8;

Fig. 10 is a perspective view of an inserting device for use with a barbed tissue connector of the present invention; and

Fig. 11 is a view showing the inserting device and connector in a wound.

DESCRIPTION OF THE PREFERRED EMBODIMENTS

The present invention allows a surgeon to rapidly and securely attach the edges of a wound in human tissue without the necessity for threading and tying numerous individual stitches or for using a complicated or elaborate tool. As used herein, the term "wound" means an incision, laceration, cut, or other condition where suturing, stapling, or the use of another tissue connecting device might be required.

With reference to Figs. 1 and 2, there is shown a barbed tissue connector 2 constructed in accordance with the present invention. Connector 2 includes a body 4 which is generally circular in cross section and a plurality of closely-spaced barbs 6 which extend around the periphery of the body 4. A pointed end

9 is formed on the body 4 to facilitate penetration of the connector 2 into tissue. The body 4 preferably has sufficient dimensional stability to assume a substantially rigid configuration during use and is sufficiently resilient to return to a predetermined shape after deflection therefrom. In some applications, it may be desirable for the body 4 to be flexible and substantially nonresilient so that the shape of an inserted connector will be determined by surrounding tissue.

Barbs 6 serve to hold the connector in tissue and resist retraction of the connector from the tissue. The barbs 6 can be arranged in any suitable pattern, for example, in a helical pattern as shown in Fig. 1. In a helical pattern of barbs 6, it is preferable that the number of barbs occupying one revolution not be an integer, thereby avoiding parallel axial rows of barbs; such an arrangement provides a more uniform distribution of forces on the tissue and lessens the tendency of an inserted connector 2 to cut through tissue. If the number of barbs in one revolution is not an integer, the barbs in successive revolutions will be offset, as shown in Fig. 2, and the amount of offset will determine which barbs are in axial alignment. For example, if the barbs in successive revolutions are offset by $1/2$ barb, the barbs in every second revolution will be in axial alignment, and by extension, if the barbs in each successive revolution are offset by $1/x$ barb, the barbs in every x revolution will be in axial alignment.

As shown in Fig. 1, each barb 6 includes a first side 8 which forms an obtuse angle alpha with the body 4 and a second side 10 which forms an acute angle beta with the body 4. Each

barb 6 tapers to a point 7, and the amount of difference between the angle alpha of side 8 and angle beta of side 10 will control the amount of taper in the barb 6. A barb 6 which tapers from a broad base to a narrow tip can be effective in resisting retraction, yet will yield toward the body 4 during insertion to reduce the effort and tissue damage associated with insertion of the connector 2. The barbs 6 can be generally conical, as shown in Fig. 1, or the barbs 6 can be any other shape which will function in substantially the same manner as the conical barbs.

The configuration of barbs 6 and the surface area of the barbs can vary depending upon the tissue in which the connector 2 is used. The proportions of the barbs 6 can remain relatively constant while the overall length of the barbs and the spacing of the barbs are determined by the tissue being connected. For example, if the connector 2 is intended to be used to connect the edges of a wound in skin or tendon, each barb 6 can be made relatively short to facilitate entry into this rather firm tissue. If the connector 2 is intended for use in fatty tissue, which is relatively soft, the barbs can be made longer and spaced farther apart to increase the holding ability in the soft tissue.

As shown in Fig. 1, the barbs 6 on connector 2 have a uniform unidirectional configuration, that is, the barbs 6 are uniformly spaced on body 4 and all the sides 8 are oriented in the same direction, facing pointed end 9. Connector 2 can be inserted into tissue with the sides 8 of each barb 6 facing in the direction of motion. Connector 2 will prevent movement of tissue in the direction in which it was inserted. A pair of connectors 2 inserted adjacent to each other and in opposite

directions will prevent movement of tissue in either direction across a wound.

Connector 2 can be formed of a material sufficiently hard for point 9 to pierce tissue and enable the connector to be inserted in tissue when a substantially axial force is applied to body 4. Connector 2 is preferably composed of a bioabsorbable compound, such as a polyglycolic acid or polylactic acid polymer or copolymer. The use of a bioabsorbable material eliminates the necessity of removing the connector from the patient, which can be a painful and possibly dangerous process. Connector 2 can be formed, for example, by injection molding.

In one representative example of connector 2 for use in muscular tissue, the body 4 is formed from polyglycolic acid, has a length of 1 to 5 cm, and a diameter of about 1 mm. The diameter of a circle extending around points 7 of barbs 6 will be about 3 mm, and the barbs are spaced apart from each other on body 4 by a distance of 1 mm. Side 8 forms an angle of 135 degrees with the body 4 and side 10 forms an angle of 75 degrees with the body 4.

In Fig. 3, there is shown a second embodiment of the present invention in which barbs 16 are arranged in a uniform bidirectional configuration on a barbed tissue connector 12. Barbs 16 are constructed in the same manner as barbs 6 on connector 2. A first set of barbs 15 on connector 12 are arranged in a helical pattern and face a pointed end 20, and a second set of barbs 16 on connector 12 are arranged in a helical pattern and face a pointed end 21. Each of the pointed ends 20, 21 should be sufficiently hard and sharp to easily penetrate

tissue in which the connector is to be used. Connector 12 is particularly suitable for applications where the edges of a wound are prone to separate. Connector 12 can be used by inserting one of the ends, for example end 20, into a first side of a wound (not shown), spreading the wound slightly to expose the second side of the wound, inserting the end 21 of the connector 12 into the second side of the wound, and then pressing the edges of the wound together. The barbs 15 and 16 on the ends of the connector 12 will grasp the tissue on each side of the wound and prevent the edges of the wound from spreading.

With reference to Fig. 4, there is shown another embodiment of the present invention in which a barbed tissue connector 22 has a nonuniform bidirectional configuration. Connector 22 comprises a pointed end 23 and one or more barbs 26 facing a first direction which alternate with one or more barbs 27 facing a second direction. At each axial location, there can be a number, e.g. 4-9, of circumferentially-spaced barbs 26 or 27. To insert connector 22 into tissue, the surgeon would use an inserting device 80 as described below. The arrangement of barbs 26 and 27 on connector 22 prevent any localized movement of tissue relative to the connector in an axial direction.

With reference to Fig. 5, there is shown another embodiment of the present invention in which a barbed tissue connector 32 has a uniform bidirectional configuration. Connector 32 comprises a body 34 having pointed ends 33 and 35. A plurality of axially-spaced barbs 36 adjacent pointed end 33 face toward end 35, and a plurality of axially-spaced barbs 37 adjacent pointed end 35 face toward end 33. Barbs 36 and 37 can be

circumferentially-spaced around body 34 at each axial location, or the barbs 36 and 37 can be of the same construction and arranged in the same pattern as barbs 6 on connector 2. To insert a connector 32, the surgeon would use an inserting device 80 as described below. If the body 34 of the connector 32 is sufficiently rigid, the connector 32 would prevent tissue retained by the barbs 36 from moving toward end 35 and tissue retained by barbs 37 from moving toward end 33. It will be apparent that only one end of connector 32 needs to be pointed; two pointed ends are preferable, however, so that the surgeon does not have to take the time to insure that connector 32 is oriented in the inserting device 80 with a pointed end protruding from the inserting device.

With reference to Figs. 6 and 7, there is shown another embodiment of the present invention in which a barbed tissue connector 42 comprises a body 44 having a pointed end 45 for penetration into tissue. A head 47 is formed on an opposite end of body 44. A plurality of circumferentially-spaced barbs 46 are formed on body 44 at each of a number of axial locations. As shown in Fig. 7, three barbs 46 are formed at each axial location; however, more or less than three barbs 46 could be used for certain applications. Barbs 46 include a first side 48 formed at an obtuse angle to the body 44 and a second side 49 which projects from body 44 at an acute angle. The connector 42 can be forced into tissue by applying a force to the head 47. The connector 42 can be applied by hand, or it can be inserted using an inserting device 80 as described below.

The connector 42 can be formed entirely of a bioabsorbable material, or the head 47 and the body 44 can be composed of different materials. For example, the body 44 can be composed of a bioabsorbable material, and the head 47 can be composed of metal for superior strength and to facilitate insertion of the connector 42. Head 47 can be made flat, as shown in Fig. 6, or the head can be formed by a single ring of barbs (not shown) facing in a direction opposite to that of the barbs 46.

In use, a series of connectors 42 can be inserted into tissue, such as along the edges and in the field of a skin graft. After an adequate amount of time has passed for the wound to heal, the tissue beneath each head 47 could be depressed slightly to permit the head 47 to be cut from the body 44. The tissue would then rise up over the cut end of the body. Such a process would reduce scarring which could result from a long-term projection of the body 44 through tissue and would eliminate the necessity to remove connectors 42 from the patient.

With reference to Figs. 8 and 9, there is shown another embodiment of the present invention in which a barbed tissue connector 52 has a uniform unidirectional configuration. Connector 52 comprises a body 54 having a non-circular cross-sectional shape. Body 54 includes a plurality of barbs 56 which are generally triangular in cross section and are equally spaced around the periphery of the body at a series of axial locations. Each of the barbs 56 includes a first side 58 disposed at an obtuse angle to body 54 and a second side 60 disposed at an acute angle to the body. Body 54 includes a pointed end 53 to facilitate entry in tissue. Use of a non-circular

cross-sectional shape increases the surface area of the connector 52 and facilitates the formation of the multiple barbs on the connector. For example, barbs 56 can be formed on a piece of stock having a triangular cross section by removing material at successive axial locations from the three edges of the stock. It will be apparent that a similar process could be used to form barbs on stock of a different cross section (not shown), for example, a rectangular or hexagonal cross section.

In the use of the disclosed connectors, such as connectors 2 and 42, the surgeon can grip the connector in one hand and push the connector into the tissue. As an alternative to directly inserting the connectors into the tissue, the surgeon can use an inserting device 80 as shown in Figs. 10 and 11. The inserting device 80 comprises a circular tubular body 82. The tubular body 82 can be generally arcuate in an axial direction, and the body 82 is sufficiently long to contain at least a portion of a barbed tissue connector C. Device 80 has an inwardly tapered leading end 84 and an outwardly tapered, or flared, trailing end 86. A handle 83 is provided on body 82 adjacent trailing end 86 to enable the surgeon to manipulate the inserting device 80.

In order to facilitate entry of the connector C and the device 80 into tissue, a connector C is positioned in tubular body 82 with a pointed end P of the connector C extending from leading end 84. In a preferred embodiment, the interior diameter of the body 82 is made slightly smaller than the outside diameter of the connector C so that the barbs B of a connector C in the body 82 will press against the body 82; as a result, the

connector C will be retained in the body 82 during insertion in tissue with the point P properly positioned outside of the body 82. The connector can also be positioned in body 82 with a barb B outside of body 82 to insure that the connector C will not be pushed back in the body 82 during insertion. In one application of device 80, the surgeon inserts the body 82 having connector C therein into the patient's tissue 87 until the connector C reaches a desired position, for example, the position shown in Fig. 11. Device 80 is then withdrawn in the direction of arrow 90, and a barb, or barbs, B on the connector C penetrates and catches the tissue 87 to hold the connector C in the inserted position.

Use of the inserting device 80 is particularly recommended when the connector C includes multiple barbs facing more than one direction, such as connectors 22 and 32, or when the connector is too flexible for insertion without additional support.

While the present invention has been described with respect to certain preferred embodiments thereof, it is to be understood that numerous variations in the details of construction, the arrangement and combination of parts, and the type of materials used may be made without departing from the spirit and scope of the invention.

CLAIMS

What is claimed is:

1. A barbed tissue connector comprising:

an elongated body having a point formed on one end, said body being formed of a material sufficiently hard for said point to pierce tissue and enable said connector to be inserted in tissue when a substantially axial force is applied to said body; and

a plurality of barbs projecting from said body, said barbs being disposed around the periphery of said body along a length of the body which extends from adjacent said one end to a predetermined location on the body, said barbs being configured such that they are yieldable in a direction toward said body and are generally rigid in an opposite direction, and said barbs being sufficiently resilient to return to a predetermined position after deflection therefrom.

2. A barbed tissue connector, as defined in claim 1, wherein said body is formed of a bioabsorbable material.

3. A barbed tissue connector, as defined in claim 2, wherein said material is polyglycolic acid.

4. A barbed tissue connector, as defined in claim 1, wherein said body has sufficient dimensional stability to assume a substantially rigid configuration during use thereof.

5. A barbed tissue connector, as defined in claim 1, wherein said body is sufficiently resilient to return to a predetermined shape after deflection therefrom.

6. A barbed tissue connector, as defined in claim 1, wherein said body is flexible and substantially nonresilient whereby the

shape of an inserted connector will be determined by surrounding tissue.

7. A barbed tissue connector, as defined in claim 1, wherein barbs are formed in a helical pattern on said body.

8. A barbed tissue connector, as defined in claim 1, wherein successive revolutions of said barbs are offset in a circumferential direction by $1/x$ barb whereby said barbs on said body are in axial alignment every x revolutions.

9. A connector, as defined in claim 1, wherein said barbs are arranged in a uniform unidirectional configuration.

10. A barbed tissue connector comprising:

an elongated body having a point formed on one end, said body being formed of a bioabsorbable material and having sufficient dimensional stability to assume a substantially rigid configuration during use thereof, said body being sufficiently resilient to return to a predetermined shape after deflection therefrom;

a plurality of axially-spaced barbs on said body extending from adjacent said one end to a predetermined location on said body, said barbs being configured such that they are yieldable in a direction toward said body and are generally rigid in an opposite direction, and said barbs being sufficiently resilient to return to a predetermined shape after deflection therefrom.

11. A connector, as recited in claim 10, wherein each of said barbs has a first side which forms an obtuse angle with said body and second side which forms an acute angle with said body.

12. A connector, as recited in claim 11, wherein said barbs are uniformly axially spaced on said body, and said barbs face toward said one end.
13. A connector, as recited in claim 10, wherein a plurality of barbs are circumferentially spaced at each of a series of axial locations.
14. A connector, as recited in claim 10, wherein said body has a circular cross-section.
15. A connector, as recited in claim 10, wherein said body has a non-circular cross section.
16. A connector, as recited in claim 15, wherein said body has a generally triangular cross-section.
17. A connector, as recited in claim 10, wherein said connector includes a plurality of axially-spaced barbs extending from adjacent an opposite end to another predetermined location on said body.
18. A connector, as recited in claim 17, wherein said axially-spaced barbs extending from adjacent said one end face said one end, and said axially-spaced barbs extending from adjacent said opposite end face said opposite end.
19. A connector, as recited in claim 18, wherein said barbs extending from adjacent said one end are arranged in a helical pattern and said barbs extending from adjacent said opposite end are arranged in a helical pattern.
20. A connector, as recited in claim 17, wherein said axially-spaced barbs extending from adjacent said one end face said opposite end, and said axially-spaced barbs extending from adjacent said opposite end face said one end.

21. A connector, as recited in claim 10, wherein certain adjacent barbs face toward each other.
22. A connector, as defined in claim 10, wherein said body has a head formed thereon at an end opposite said one end.
23. A connector, as defined in claim 22, wherein said head is formed by one or more barbs.
24. A barbed tissue connector comprising:
an elongated body; and
a plurality of axially spaced barbs on said body, each of said barbs having a first side which forms an obtuse angle with said body and a second side which forms an acute angle with said body, certain of said barbs having first sides facing one end of said body and the remainder of said barbs having first sides facing an opposite end of said body, and said barbs being configured such that they are yieldable in a direction to move said second sides toward said body and are generally rigid in an opposite direction.
25. A connector, as recited in claim 24, wherein axially-spaced barbs extending from adjacent said one end face said one end, and axially-spaced barbs extending from adjacent said opposite end face said opposite end.
26. A connector, as recited in claim 24, wherein axially-spaced barbs extending from adjacent said one end face said opposite end, and axially-spaced barbs extending from adjacent said opposite end face said one end.
27. A connector, as recited in claim 24, wherein certain adjacent barbs face toward each other.

28. A connector, as defined in claim 24, wherein said barbs are arranged in a uniform bidirectional configuration.

29. A connector, as recited in claim 24, said barbs are arranged in a nonuniform bidirectional configuration.

30. A barbed tissue connector comprising:

an elongated body, said body being formed of a generally rigid bioabsorbable material and being sufficiently resilient to return to a predetermined shape after deflection therefrom, said body having a leading end which is of a shape to facilitate penetration into said tissue; and

a plurality of axially and circumferentially spaced barbs projecting from said body, said barbs being disposed around the periphery of said body from adjacent said leading end to a predetermined point on said body, each of said barbs having a first side which forms an obtuse angle with said body and a second side which forms an acute angle with said body, and said barbs being configured such that they are yieldable in a direction toward said body and are generally rigid in an opposite direction.

31. An inserting device for use with a barbed tissue connector, said connector comprising an elongated body and a plurality of axially spaced barbs projecting from said elongated body, said barbs being configured such that they are yieldable in the direction of said elongated body and are generally rigid in the opposite direction, said device comprising:

a tubular body having an interior of a size sufficient to receive a barbed tissue connector, said tubular body having a leading end having an opening therein and a trailing end having

an opening therein, and said opening in said leading end being sufficiently large to permit said connector to be extracted therefrom.

32. An inserting device, as recited in claim 31, wherein said tubular body is substantially rigid.

33. An inserting device, as recited in claim 31, wherein said leading end is tapered inwardly to facilitate the insertion of said device in tissue.

34. An inserting device, as recited in claim 31, wherein said trailing end is tapered outwardly to facilitate the insertion of said connector in said tubular body.

35. An inserting device, as recited in claim 31, wherein said tubular body has a generally circular cross section.

36. An inserting device, as recited in claim 35, wherein an inside diameter of said tubular body is slightly less than an outside diameter of said connector.

37. An inserting device, as recited in claim 31, wherein said tubular body is generally arcuate in an axial direction.

38. An inserting device, as recited in claim 31, wherein said device has a handle on said tubular body adjacent said trailing end.

39. A method of connecting tissue using a barbed tissue connector having an elongated body and a plurality of axially spaced barbs projecting from said elongated body, said elongated body having a pointed end, said barbs being configured such that they are yieldable in the direction of said elongated body and are generally rigid in the opposite direction, said method comprising the steps of:

positioning said connector in an inserting device having a tubular body such that said pointed end and at least one barb protrude from said tubular body;

inserting the device having the connector therein into tissue such that said one barb is engaging tissue; and

moving said device relative to said connector to extract the device from the tissue while leaving the connector in the tissue.

40. A method, as defined in claim 39, wherein said connector includes a first set of barbs facing said pointed end and a second set of barbs facing an opposite end of said connector.

41. A device for use in repairing a wound, said device comprising:

a tubular body having a leading end with an opening therein and a trailing end with an opening therein; and

a barbed tissue connector having an elongated body and a pointed end on said elongated body, said connector having a plurality of axially spaced barbs projecting from said elongated body, and said connector being positioned in said tubular body with said pointed end protruding from said opening in the leading end.

42. A device, as recited in claim 41, wherein at least one barb protrudes from said opening in the leading end.

43. A device, as recited in claim 42, wherein said tubular body is generally arcuate in an axial direction.

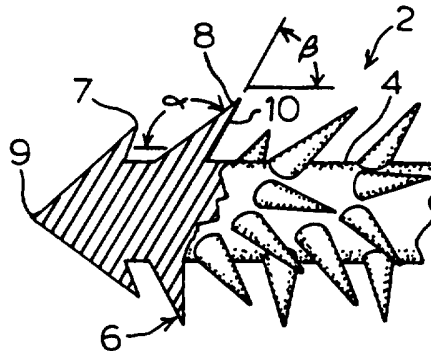

FIG. 1

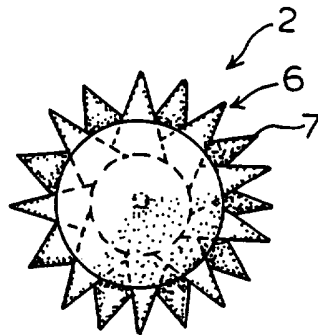

FIG. 2

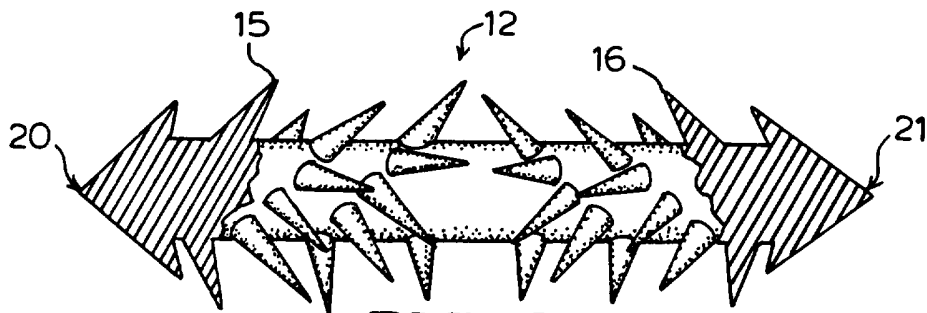

FIG. 3

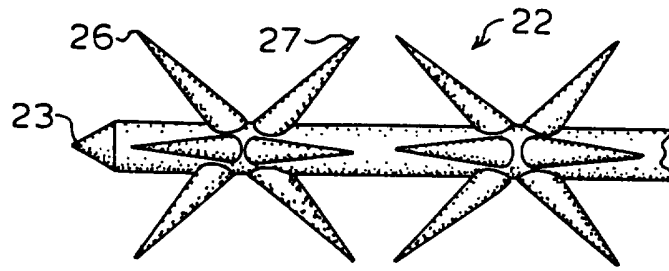

FIG. 4

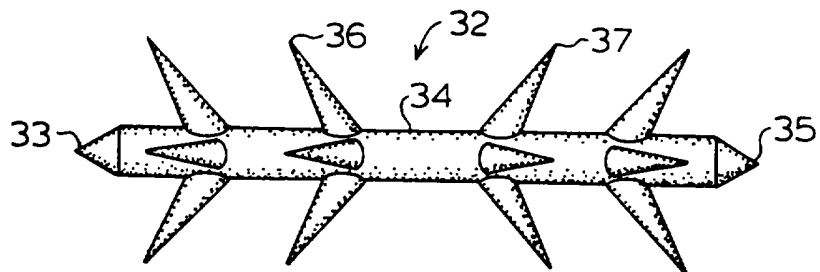

FIG. 5

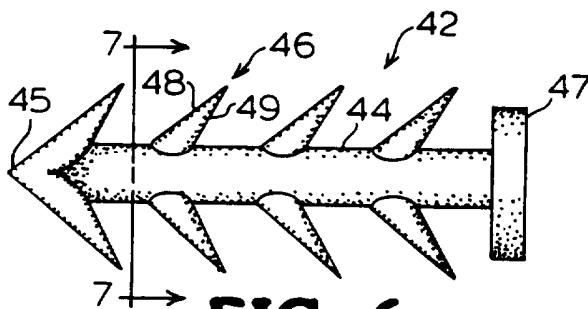

FIG. 6

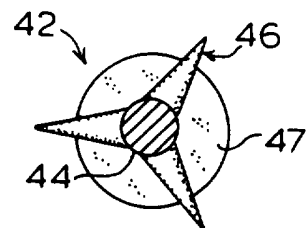

FIG. 7

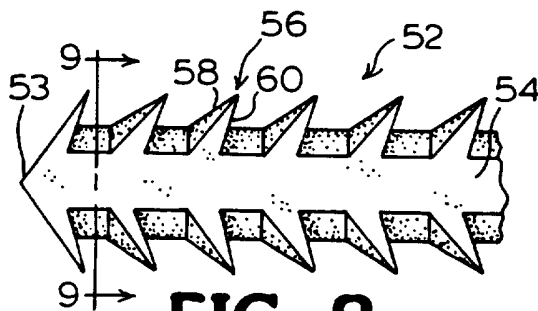

FIG. 8

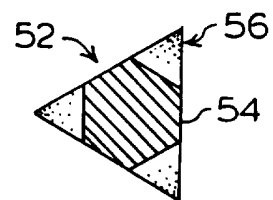

FIG. 9

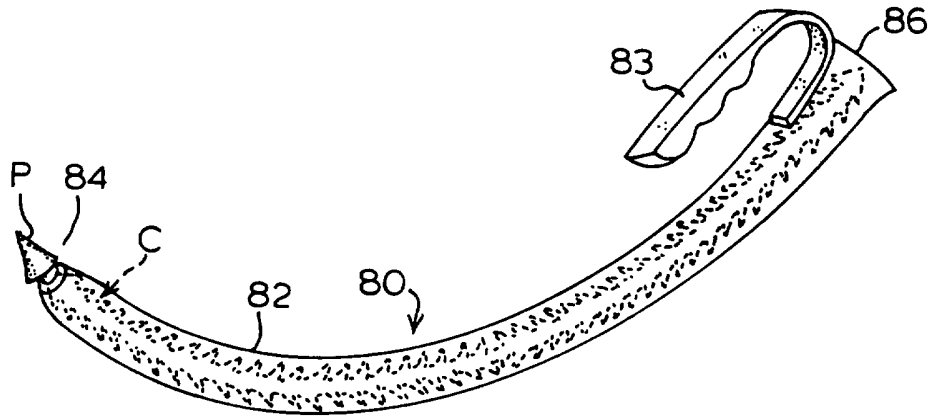

FIG. 10

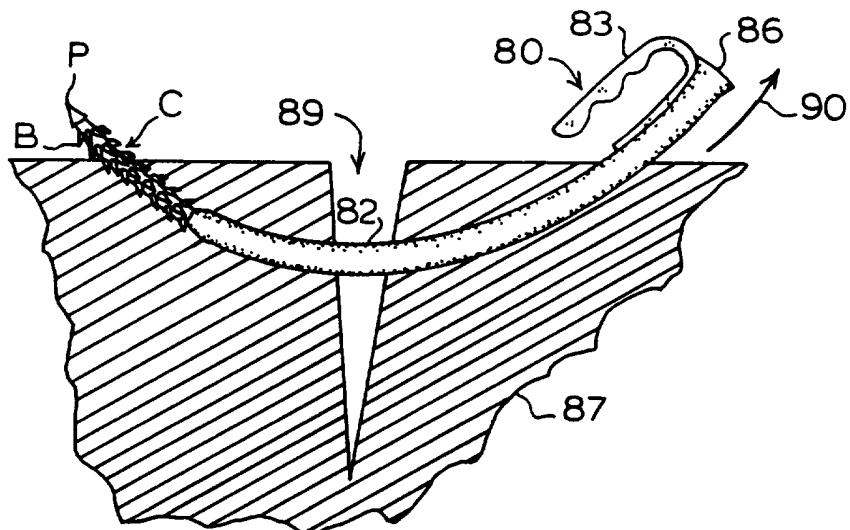

FIG. 11

INTERNATIONAL SEARCH REPORT

International application No.
PCT/US94/09631

A. CLASSIFICATION OF SUBJECT MATTER

IPC(5) :A61B 17/00
US CL :606/151

According to International Patent Classification (IPC) or to both national classification and IPC

B. FIELDS SEARCHED

Minimum documentation searched (classification system followed by classification symbols)

U.S. : 24/453, 455, 458; 411/456, 510, 913, 922; 604/413, 905; 606/117, 139, 144, 148, 151-154, 159, 213, 215, 216, 219,

Documentation searched other than minimum documentation to the extent that such documents are included in the fields searched
NONE

Electronic data base consulted during the international search (name of data base and, where practicable, search terms used)
NONE

C. DOCUMENTS CONSIDERED TO BE RELEVANT

Category*	Citation of document, with indication, where appropriate, of the relevant passages	Relevant to claim No.
Y	US, A, 3,494,006, (G. C. BRUMLIK), 10 February 1970. See entire document.	1-43
Y	US, A, 5,246,441, (ROSS ET AL.), 21 September 1993. See entire document.	2, 3, 10-24, 30
Y	US, A, 1,886,721, (J. R. O'BRIEN), 08 November 1932. See entire document.	8, 19, 29
Y	US, A, 5,207,694, (BROOME), 04 May 1993. See entire document.	31-43

Further documents are listed in the continuation of Box C. See patent family annex.

* Special categories of cited documents:	*T	later document published after the international filing date or priority date and not in conflict with the application but cited to understand the principle or theory underlying the invention
A document defining the general state of the art which is not considered to be part of particular relevance	*X*	document of particular relevance; the claimed invention cannot be considered novel or cannot be considered to involve an inventive step when the document is taken alone
E earlier document published on or after the international filing date	*Y*	document of particular relevance; the claimed invention cannot be considered to involve an inventive step when the document is combined with one or more other such documents, such combination being obvious to a person skilled in the art
L document which may throw doubts on priority claim(s) or which is cited to establish the publication date of another citation or other special reason (as specified)	*Z*	document member of the same patent family
O document referring to an oral disclosure, use, exhibition or other means		
P document published prior to the international filing date but later than the priority date claimed		

Date of the actual completion of the international search 10 NOVEMBER 1994	Date of mailing of the international search report 09 DEC 1994
Name and mailing address of the ISA/US Commissioner of Patents and Trademarks Box PCT Washington, D.C. 20231 Facsimile No. (703) 305-3230	Authorized officer <i>Peter Aschenbrenner</i> PETER ASCHENBRENNER Telephone No. (703) 308-3523