



- (51) International Patent Classification: *A21C 15/00* (2006.01) *A23G 3/28* (2006.01)
- (21) International Application Number: PCT/NL2016/050241
- (22) International Filing Date: 7 April 2016 (07.04.2016)
- (25) Filing Language: English
- (26) Publication Language: English
- (30) Priority Data:

2014589	7 April 2015 (07.04.2015)	NL
2014712	24 April 2015 (24.04.2015)	NL
2015427	11 September 2015 (11.09.2015)	NL
- (71) Applicant: **REYNARDS INTERNATIONAL HOLDING B.V.** [NL/NL]; Everdenberg 95, 4902 TT Oosterhout (NL).
- (72) Inventor: **VAN DER STRAATEN, Jan Cornelis**; Nieuw Wolfslaarlan 28, 4854 EA Bavel (NL).
- (74) Agent: **JACOBS, Bart**; Bezuidenhoutseweg 57, 2594 AC Den Haag (NL).
- (81) Designated States (*unless otherwise indicated, for every kind of national protection available*): AE, AG, AL, AM, AO, AT, AU, AZ, BA, BB, BG, BH, BN, BR, BW, BY, BZ, CA, CH, CL, CN, CO, CR, CU, CZ, DE, DK, DM, DO, DZ, EC, EE, EG, ES, FI, GB, GD, GE, GH, GM, GT, HN, HR, HU, ID, IL, IN, IR, IS, JP, KE, KG, KN, KP, KR, KZ, LA, LC, LK, LR, LS, LU, LY, MA, MD, ME, MG,

[Continued on next page]

(54) Title: PIPING BAG ASSEMBLY, CLOSING ASSEMBLY, PIPING BAG, AND METHOD

(57) Abstract: The present invention relates to a piping bag assembly. It further relates to a closing assembly to be used in such a piping bag assembly. In addition, it also relates to a piping bag manufactured using the piping bag assembly and a corresponding method of assembly. According to the invention, a piping bag assembly is provided that comprises a tapered bag, a nozzle, and a nozzle closing element allowing a closeable piping bag to be assembled by placing the nozzle and nozzle closing element, coupled to each other, through the bottom opening of the tapered bag via the top opening, and by subsequently fixing the nozzle near its mounting end in the tapered bag by pulling the nozzle closing element.

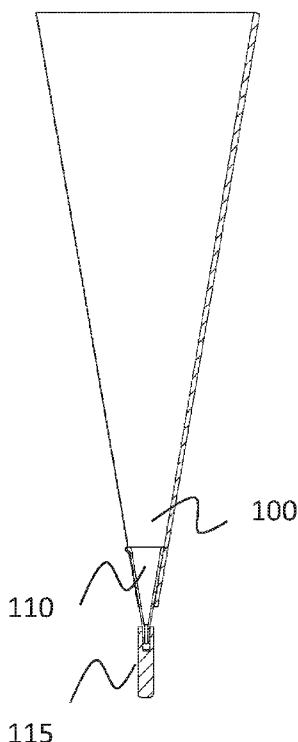

FIG. 4A



MK, MN, MW, MX, MY, MZ, NA, NG, NI, NO, NZ, OM, PA, PE, PG, PH, PL, PT, QA, RO, RS, RU, RW, SA, SC, SD, SE, SG, SK, SL, SM, ST, SV, SY, TH, TJ, TM, TN, TR, TT, TZ, UA, UG, US, UZ, VC, VN, ZA, ZM, ZW.

SI, SK, SM, TR), OAPI (BF, BJ, CF, CG, CI, CM, GA, GN, GQ, GW, KM, ML, MR, NE, SN, TD, TG).

Declarations under Rule 4.17:

- *as to the identity of the inventor (Rule 4.17(i))*
- *of inventorship (Rule 4.17(iv))*

Published:

- *without international search report and to be republished upon receipt of that report (Rule 48.2(g))*

(84) Designated States (*unless otherwise indicated, for every kind of regional protection available*): ARIPO (BW, GH, GM, KE, LR, LS, MW, MZ, NA, RW, SD, SL, ST, SZ, TZ, UG, ZM, ZW), Eurasian (AM, AZ, BY, KG, KZ, RU, TJ, TM), European (AL, AT, BE, BG, CH, CY, CZ, DE, DK, EE, ES, FI, FR, GB, GR, HR, HU, IE, IS, IT, LT, LU, LV, MC, MK, MT, NL, NO, PL, PT, RO, RS, SE,

Piping bag assembly, closing assembly, piping bag, and method

The present invention relates to a piping bag assembly. It further relates to a closing assembly to be used in such a piping bag assembly. In addition, it also relates to a piping bag manufactured using the piping bag assembly and a corresponding method of assembly.

Piping bags are well known in the art. For instance, WO 2007089138 A1 discloses a piping bag that can be used to dispense foodstuffs such as whipped cream. Such piping bag can for instance be used to decorate cakes. To that end, a user fills the piping bag with the foodstuffs to be dispensed. By squeezing the piping bag, a suitable amount of foodstuffs can be dispensed.

The known piping bag comprises an elongated tapered bag having a first opening for receiving foodstuffs and a second opening, smaller than the first opening, for dispensing the foodstuffs. A nozzle can be attached near the second opening. Such nozzle can define a particular opening or circumferential edge to achieve different shapes of the dispensed foodstuffs. To connect the nozzle to the piping bags, several techniques are known. For instance, US 3847523 A discloses a piping bag wherein a coupling element is placed through the first opening. The coupling element partially protrudes from the second opening, thereby revealing a screw thread onto which different nozzles can be mounted. A similar approach is disclosed in US 6,153, 238, wherein a decorator tip with releasable cap is arranged through the first opening of the bag. To allow proper arrangement of the decorator tip, it is provided with a shoulder. Near its second opening, the bag is provided with an inwardly oriented step that provides a support for the shoulder of the decorator tip.

In the abovementioned known piping bags, the nozzle is positioned by the user by inserting a hand through the first opening for grasping and pushing the nozzle.

The present invention relates in particular to applications in which only a very limited amount of foodstuffs is to be dispensed. For instance, chocolate can be dispensed to form letters or other decorations. For these kinds of applications, cornet-shaped bags are typically used. These bags are a particular kind of piping bags that are normally made from baking paper, which is folded into a cornet shape. After folding, the tip is cut at a desired height. By choosing the cutting line, the size of the dispensing opening can be defined.

The abovementioned cornet-shaped bags are, compared to regular piping bags, relatively small. Typically, a cornet-shaped bag has a length of about 5 to 25 centimeter with a dispensing opening in between 0.05 and 0.15 centimeter. This small size allows a user to use a pencil-type grip to hold the bag. Consequently, a user can accurately dispense very small amounts of foodstuff. Such accuracy cannot be achieved using the abovementioned regular piping bags, of which the size of the bag is too large to allow a pencil-type grip and of which the dispensing opening is too large to accurately dispense the foodstuffs.

A drawback of the cornet-shaped bags made from baking paper is that these bags require some skill to make. Moreover, once made and used, the bags have to be discarded as these bags cannot be properly closed for storage.

5 A further cornet-shaped bag is disclosed in EP 0287530A2. This bag comprises a tapered tubular skirt preferably made using a thermoforming technique. The bag can be closed by a cap. This cap has an annular groove in which hooked ends of segments of the apex part of the bag are snap-engaged.

10 A drawback of this cornet-shaped bag is that it relies on the use of relatively thick material for the bag to allow the cap to be placed. This reduces ease-of-use when dispensing fine traces of foodstuffs. Furthermore, after removing the cap in this known cornet-shaped bag it can no longer be reattached to the bag.

15 It is also not possible to combine the abovementioned cornet-shaped bag with the earlier mentioned piping bags in which the nozzle was inserted through the first opening. In these latter piping bags, the user has to insert his hand through the first opening to properly attach the nozzle. It should be apparent to the skilled person that the first opening in the abovementioned cornet-shaped bags is too small for this purpose.

It is therefore an object of the present invention to provide an alternative to the known cornet-shaped bags which provides an increased ease-of-use and provides the possibility to easily arrange a nozzle and to close this nozzle after use.

20 According to a first aspect of the present invention, this object is achieved with a piping bag assembly comprising an elongated tapered bag having a first opening for receiving foodstuffs and a second opening, smaller than the first opening, for dispensing the foodstuffs. The assembly further comprises an elongated tapered nozzle having a dispensing end and a mounting end, wherein a cross section of the nozzle near the mounting end is larger than the second opening. The assembly additionally comprises an elongated nozzle closing element that comprises a cavity for receiving the dispensing end of the nozzle for closing the nozzle, wherein the nozzle closing element can be or is coupled to the nozzle such that longitudinal axes of the nozzle and the nozzle closing element are substantially parallel to each other. The nozzle closing element fits entirely through the second opening along its longitudinal direction.

30 According to the present invention, the piping bag assembly can be assembled to form a closeable piping bag by placing the nozzle and nozzle closing element, coupled to each other, through the second opening via the first opening, and by subsequently fixing the nozzle near its mounting end in the tapered bag by pulling the nozzle closing element.

35 The tapered bag is obtained from a tubular foil made from at least one of the materials from the group consisting of thermoplastic materials, such as Polyethylene (PE), Polypropylene

(PP), Ethylene-vinyl acetate (EVA), Polyvinyl chloride (PVC), or Polyamide (PA), PP or PE based thermoplastic elastomers (TPE), and PP or PE based thermoplastic vulcanizates (TPV).

The tapered bag has a length in between 5 and 25 centimeter. This length allows a user to use the so-called pencil grip to dispense the foodstuffs. The tapered nozzle has a length in between 1 and 5 centimeter. The nozzle should not be too small as this would jeopardize a proper attachment in the piping bag. However, if the nozzle is too large, it becomes increasingly difficult to dispense the foodstuffs. This is mainly due to the fact that the nozzle is typically made of inelastic and/or hard material. The part of the piping bag of which the wall is adjacent to the nozzle cannot easily be emptied by means of squeezing.

The dispensing end of the nozzle has an opening in between 0.05 and 0.25 centimeter, more preferably in between 0.07 and 0.15 centimeter, and even more preferably in between 0.08 and 0.10 centimeter. Such openings allow the fabrication of highly detailed structures using the dispensed foodstuffs, such as writing letters using dispensed chocolate.

The nozzle closing element has a length in between 1.0 and 4.0 centimeter. The length of the nozzle closing element should be sufficient to enable a user to grip the nozzle closing element in order to attach the nozzle in the piping bag.

The applicant has found that mounting the nozzle in the small tapered bag is made more convenient if the nozzle closing element is coupled thereto. Without being bound by theory, a possible explanation could be that the center of mass of the nozzle – nozzle closing element combination is such that the combination falls down through the tapered bag in such a manner that the nozzle closing element protrudes through the second opening first. Without the nozzle closing element being coupled to the nozzle, there is an increased risk of the nozzle rotating inside the tapered bag while it is falling downward. Due to the fact that the nozzle has a diameter near its mounting end that is larger than the second opening, it will then not protrude through the second opening causing inconvenience for a user. Even if the nozzle were to protrude through the second opening, for instance because it did not rotate, a user would still have to grip the nozzle near its dispensing end to pull the nozzle in order to fix the nozzle tightly in the tapered bag. Such action is not desired during the preparation of foodstuffs, wherein hygiene is of utmost importance.

According to the present invention, the nozzle closing element allows for the nozzle to be closed, thereby making it possible to store a filled piping bag for later use. In addition, the nozzle closing element facilitates placing the nozzle in the piping bag.

At least one of the nozzle and the nozzle closing element can be made from flexible material allowing the nozzle and nozzle closing element to be coupled to each other by first arranging the dispensing end in the cavity and by subsequently rotating the nozzle and nozzle closing element relative to each other causing the deformation of at least one of the nozzle and nozzle closing element. Preferably, the amount of force required to separate the nozzle and nozzle

closing element increases due to the rotation. An example of such a coupling can be found in the field of medical devices, which example is commonly referred to as a slipping Luer taper connection, as for instance described in ISO-594. Alternatively, the nozzle and the nozzle closing element may comprise mutually corresponding screw threads. The present invention does not
5 exclude other coupling means for coupling the nozzle closing element and nozzle.

To facilitate the arrangement of the nozzle in the tapered bag, the nozzle may comprise a mounting rim near its mounting end, wherein the mounting rim preferably comprises a radially protruding circumferential edge. Moreover, a wall thickness of the nozzle may be enlarged near the mounting rim to provide additional rigidity and shape stability.

10 According to the invention, the tapered bag will deform plastically when the user pulls on the nozzle after having arranged it in the piping bag through the first opening. This deformation is made possible due to the fact that the tapered bag is made from tubular foil, which, when compared to the thermoformed bags, is relatively thin.

The use of relatively thin bags has the further advantage that handling of the bag is more
15 convenient for the user as such a bag offers more of a direct feel of the foodstuffs that are held in the bag.

A region of the tapered bag near its second opening may be complementary shaped to a region of the nozzle near its mounting end. For instance, the region of the tapered bag near its second opening and the region of the nozzle near its mounting end can both be cone shaped.
20 Furthermore, the region of the tapered bag near its second opening may taper according to a first tapering angle that is substantially equal to a tapering angle of the region of the nozzle near its mounting end. The first tapering angle may be within the range from 5 to 15 degrees, preferably within the range from 7.5 to 12.5 degrees, and more preferably within the range from 9 to 11 degrees.

25 The nozzle may comprise two tapered elements that are fixedly connected to each other along the longitudinal direction of the nozzle. Moreover, the first element may be tapered according to the first tapering angle, and a tapering angle of the second element may be smaller than the first tapering angle. The second element may comprise the dispensing end. The tapering angle of the second element may be within the range from 0.5 to 5 degrees, preferably within the
30 range from 1 to 3 degrees, and more preferably within the range from 1.5 to 2.5 degrees. Moreover, the first and second elements of the nozzle may be cone shaped. The first element should be attached to the tapered bag, whereas the second element should be or can be attached to the nozzle closing element. The second element may have a length equal to for instance 10 to 40 percent of the length of the nozzle. In an example, the length of the second element is in between 0.4 and 0.8
35 cm. This provides sufficient length to couple the nozzle closing element, whereas it also provides an alignment aid when dispensing the foodstuffs.

The cavity in the nozzle closing element may be tapered. A tapering angle of the cavity is preferably substantially equal to a tapering angle of the nozzle near its dispensing end, for instance substantially equal to a tapering angle of the second element of the nozzle. Moreover, the cavity and the nozzle near its dispensing end may be complementary shaped, preferably cone shaped.

5 The nozzle closing element may comprise two elements that are fixedly connected to each other along the longitudinal direction, wherein the cavity is accommodated in the first element, and wherein the second element is flattened along the longitudinal axis of the nozzle closing element. The flattening of the second element allows a user to more easily grip the nozzle closing element such that more force may be applied for attaching the nozzle in the tapered bag and for attaching
10 the nozzle closing element to the nozzle.

The nozzle closing element and the nozzle may be two separate elements that can be coupled to each other by arranging the dispensing end of the nozzle in the cavity of the nozzle closing element. Alternatively, the nozzle closing element and the nozzle may be fixedly connected to each other thereby forming a single element. This element may comprise a tearing line or
15 perforation line along which the nozzle closing element and nozzle can be separated. The cavity may be arranged in the nozzle closing element on a side opposite to the tearing or perforation line along the longitudinal direction of the nozzle closing element. Hence, when used for the first time, a user arranges the single element in the tapered bag, with the nozzle closing element facing the second opening. Prior to dispensing foodstuffs, the user may remove the nozzle closing element,
20 after which the dispensing end of the nozzle becomes accessible. The region of the dispensing end directly adjacent the opening is preferably not attached to the nozzle closing element when nozzle and nozzle closing element are still coupled to prevent deformation of this opening when the nozzle and nozzle closing element are separated from each other. The single element may be integrally manufactured. The nozzle and the nozzle closing element may have been formed by
25 injection molding.

The nozzle and/or nozzle closing element may be manufactured from at least one of the materials from the group consisting of thermoplastic materials, such as Polyethylene (PE), Polypropylene (PP), Polycarbonate, Ethylene-vinyl acetate (EVA), Polyvinyl chloride (PVC), Acrylate, Acrylonitrile butadiene styrene (ABS), Styrene-butadiene (SB), or Polyamide (PA), PP
30 or PE based thermoplastic elastomers (TPE), and PP or PE based thermoplastic vulcanizates (TPV).

The nozzle and nozzle closing element may have been formed by first forming the nozzle by injection molding using a first material having a first color and allowing the nozzle to at least partially solidify, and to subsequently form the nozzle closing element by injection molding using
35 a second material having a second color around the dispensing end of the nozzle. The first and second materials may be different and/or the first and second colors may be different. In this

process, materials should be combined that make no or little chemical bonds between nozzle and nozzle closing element. Examples of suitable materials have been described above.

Due to thermal shrinkage after manufacturing, the nozzle closing element will be tightly clamped on the nozzle to the extent that it is possible to pull the nozzle closing element while it is still coupled to the nozzle to properly fix the nozzle in the tapered bag. Due to the absence or small amount of chemical bonds between the nozzle and nozzle closing element, it is possible for a user to separate the nozzle closing element and the nozzle, for instance after fixing the nozzle in the tapered bag.

According to a second aspect, the present invention provides a closing assembly for closing a tapered bag, comprising the nozzle and the nozzle closing element as defined above.

According to a third aspect, the present invention provides a piping bag that comprises a tapered bag, a nozzle, and a nozzle closing element as defined above, wherein the nozzle is fixed in the tapered bag, and wherein the nozzle closing element closes the nozzle. Such piping bag may hold foodstuffs. Furthermore, such bag may be sealed near its first opening. This allows foodstuffs to be traded packaged in the piping bag according to the invention. For example, a piping bag may be sold that comprises chocolate. A user may heat the piping bag, for instance in a microwave oven, to heat the chocolate in order to reach a desired viscosity. After heating, the user may remove the nozzle closing element and dispense the chocolate.

According to a fourth aspect, the present invention provides a method for manufacturing a piping bag, comprising providing the assembly as defined above, coupling the nozzle and the nozzle closing element if provided as separate elements, placing the coupled nozzle and nozzle closing element through the second opening via the first opening, and fixing the nozzle near its mounting end in the tapered bag by pulling the nozzle closing element.

Next, the invention will be described in more detail referring to the appended drawings, wherein:

Figure 1 illustrates a cornet-shaped bag that is being used for dispensing foodstuffs, wherein the user employs the so-called pencil grip;

Figure 2 illustrates a tapered bag in accordance with the present invention;

Figures 3A-3C illustrate three different embodiments of closing assemblies in accordance with the present invention; and

Figures 4A-4C illustrate the tapered bag of figure 2 after the closing assemblies of figures 3A-3C, respectively, have been placed.

In figure 1 a pencil grip is used to hold and squeeze a cornet-shaped bag 1 to dispense foodstuffs 2. As can be seen, a user's hand 3 holds bag 1 similar to a pencil allowing foodstuffs 2 to be dispensed with high precision. It should be obvious to the skilled person that a pencil grip cannot be used, at least not as effectively, when bag 1 is too large. Hence, in the art a distinction is

made between regular larger-sized piping bags that are used to dispense foodstuffs more coarsely, and cornet-shaped smaller-sized piping bags that are used to dispense foodstuffs with higher precision using the pencil grip.

Figure 2 illustrates a tapered bag 100 that can be used in the piping bag assembly according to the present invention. Here, tapered bag 100 is shown in a condition of use wherein it has a conical shape with a first opening 101 on a top side, and a second opening 102 on a bottom side. As an example, bag 100 can be obtained from a tubular foil made from at least one of the materials from the group consisting of thermoplastic materials, such as Polyethylene (PE), Polypropylene (PP), Ethylene-vinyl acetate (EVA), Polyvinyl chloride (PVC), or Polyamide (PA), PP or PE based thermoplastic elastomers (TPE), and PP or PE based thermoplastic vulcanizates (TPV). The tubular foil is provided with a seam 103 to divide the tubular foil in tapered bags 100. Moreover, a tearing or perforation line may be formed in the tubular foil to allow the separation of bags thereby forming first opening 101. A similar tearing or perforation line may be formed near seam 103.

Typically, bags 100 are provided on a roll, as illustrated on the right in figure 2 (not to scale). As can be seen, bags are connected at seam 103 and at the tearing or perforation line for forming first opening 101. Second opening 102 is normally formed only after separating a bag 100 from the roll. This can for instance be realized by a user cutting through bag 100 using conventional means, such as scissors.

Tapered bag 100 may be characterized by a length, as indicated by arrow 104, and a tapering angle, as indicated by arrow 105. The tapering angle may be defined as the angle between an imaginary line 106, representing a central and/or axial line of tapered bag 100 that passes through second opening 102, and an edge of bag 100. For convenience, such angle is typically determined when bag 100 is in a state of use, for instance in a state wherein a nozzle protrudes through second opening 102. A typical length of bag 100 varies between 5 and 25 centimeter, whereas the tapering angle may be within the range from 5 to 15 degrees, preferably within the range from 7.5 to 12.5 degrees, and more preferably within the range from 9 to 11 degrees.

Figures 3A-3C illustrate three different embodiments of closing assemblies that can be used with bag 100 to form a piping bag in accordance with the present invention. Figure 3A illustrates a first embodiment of the closing assembly comprising a cone-shaped nozzle 110 and a nozzle closing element 115. Nozzle 110 comprises a first element 111 having a mounting rim 112 arranged near its top end, and a second element 113 having a dispensing end 114 at the bottom side.

Nozzle closing element 115 comprises a first part 116 that is provided with a cavity for receiving dispensing end 114, and a second part 117 that is flattened to facilitate the gripping of nozzle closing element 115.

Dispensing end 114 defines a dispensing opening that may have a diameter in between 0.05 and 0.25 centimeter, more preferably in between 0.07 and 0.15 centimeter, and even more preferably in between 0.08 and 0.10 centimeter. Second element 113 may be cone-shaped characterized by a tapering angle within the range from 0.5 to 5 degrees, preferably within the range from 1 to 3 degrees, and more preferably within the range from 1.5 to 2.5 degrees. Here, the tapering angle may be defined as the angle between a central and/or axial line through second element 113 and an edge thereof.

Dispensing end 114 may itself be cone shaped as illustrated in figure 3A. For instance, the length of dispensing end 114 may be in the range between 0.05 and 0.2 centimeter, and more preferably around 0.1 centimeter. Furthermore, the tapering angle of dispensing end 114 may lie in a range between 10 and 50 degrees, and more preferably between 25 and 35 degrees. Such angle allows a user to apply foodstuffs under an appropriate angle. Normally, a user will not apply foodstuffs in a manner perpendicular to the substrate, such as a cake. Moreover, by working under an angle, the user is able to better inspect his work and the user will less likely damage the substrate during application of the foodstuffs.

The wall thickness of dispensing end 114 near the actual dispensing opening is as small as possible, preferably below 0.02 centimeter. This allows the user to apply the foodstuffs more or less directly on the substrate. By using a scratching technique, very thin lines of foodstuffs can be applied.

The internal diameter of dispensing end 114 generally increases when moving away from the actual dispensing opening. This allows the user to cut off a part of dispensing end 114 to thereby achieve a larger opening. Such opening may be necessary when working with relatively thick foodstuffs, such as chocolate.

Cone-shaped nozzle 110, or part thereof such as dispensing end 114, and/or nozzle closing element 115 may be transparent. This allows a user to identify possible air bubbles in the foodstuffs. Additionally or alternatively, cone-shaped nozzle 110, or part thereof such as dispensing end 114, and/or nozzle closing element 115 may be colored. This allows for instance a user to identify a piece of dispensing end 114 that has been cut off or to identify nozzle closing element 115 when it has inadvertently fallen onto the substrate.

Cone-shaped nozzle 110 is generally flexible but it should be stiff enough to prevent it from being pushed through tapered bag 100. When a piece of foodstuff is blocking cone-shaped nozzle 110 and/or dispensing end 114 in particular, a user may operate on or remove the blocking foodstuff to clear the passage inside nozzle 110 and/or dispensing end 114. For instance, chocolate may sometimes comprise small grains of chocolate that have not been molten sufficiently. The user may then shape the cone between mounting rim 112 and dispensing end 114 to change the shape of such grains. The material used for the fabrication of tapered bag 100, cone-shaped nozzle 110,

and/or nozzle closing element 115 is preferably stable up to and above 100 degrees Centigrade. This ensures that the shape of these components is maintained even when working with hot foodstuffs.

5 Tapered nozzle 110 may have a length in between 1 and 5 centimeter, wherein the length is measured along a central axis of nozzle 110. Nozzle closing element may have a length in between 1.0 and 4.0 centimeter, wherein a larger part is flattened. The cavity in first part 116 also may have cone shape. Furthermore, the tapering angle of this cone shape is substantially equal to the tapering angle of second element 113. This allows a cone-to-cone attachment, wherein nozzle closing element 115 is placed with its cavity over dispensing end 114, and at least partially over
10 second element 113, and wherein nozzle closing element 115 and nozzle 110 are subsequently mutually rotated about their longitudinal axis.

Figure 4A illustrates how the closing assembly of figure 3A can be used in combination with bag 100 of figure 2 for forming a closeable piping bag. Prior to arranging nozzle 110 in bag 100 it is coupled to nozzle closing element 115. This closing assembly is then, in a coupled state,
15 inserted into first opening 101 of bag 100. It will then fall downward and will protrude partially through second opening 102. More in particular, the size of second opening 102 prohibits nozzle 110 to completely pass through second opening 102, unlike nozzle closing element 115. A user may then firmly pull on nozzle closing element 115 in a direction parallel to the longitudinal direction of nozzle 110 and away from bag 100. This will result in mounting rim 112 firmly
20 attaching itself in the walls of bag 100, as illustrated in figure 4A. A user may then fill bag 100 with foodstuffs through first opening 101, remove nozzle closing element 115, and start dispensing foodstuffs for instance by using the pencil grip illustrated in figure 1. After use, a user may close bag 100 by using nozzle closing element 115.

Figures 3B and 3C, and corresponding figures 4B and 4C, respectively, illustrate
25 alternatives to the closing assembly of figure 3A. For instance, the closing assembly illustrated in figures 3B and 4B comprises a nozzle 210 comprising a first element 211 with a mounting rim 212, and a second element 213. Nozzle closing element 215 comprises a first part 216 having a cavity, and a second part 217. Unlike the closing assembly of figure 3A, nozzle 210 and nozzle closing element 215 are not provided as two separate items, but as an integral part. A perforation or tearing
30 line, or other weakening structure, is provided near the dispensing end of second element 213. After the closing assembly is placed in bag 100, as illustrated in figure 4B, a user may, prior to use, remove nozzle closing element 215. This will open up the dispensing opening of second element 213. After use, a user may close bag 100 using nozzle closing element 215, wherein it is noted that the cavity is arranged in the bottom part of nozzle closing element 215, as illustrated in figure 4B.

35 The closing assembly illustrated in figures 3C and 4C show a further alternative to the closing assembly of figure 3A. This closing assembly comprises a nozzle 310 comprising a first

element 311 with a mounting rim 312, and a second element 313. Nozzle closing element 315 comprises a first part 316 having a cavity, and a second part 317. Unlike the closing assembly of figure 3A, nozzle 310 and nozzle closing element 315 are not provided as two separate items, but as a single part. In this case, nozzle closing element 315 is formed by injection around a part of
5 second element 313 in such manner that a user may still separate nozzle 310 and nozzle closing element 315 by applying sufficient force. This can be achieved by combining materials for the nozzle and nozzle closing element that make no or little chemical bonds between nozzle and nozzle closing element.

After the closing assembly is placed in bag 100, as illustrated in figure 4C, a user may,
10 prior to use, remove nozzle closing element 315. This will open up the dispensing opening of second element 313. After use, a user may close bag 100 using nozzle closing element 315.

In the description above, various embodiments have been described to illustrate the inventive concept of the present invention. However, a skilled person will readily understand that the present invention is not limited to these embodiments but that various modifications are
15 possible without departing from the scope of the invention that is defined by the appended claims.

CLAIMS

1. A piping bag assembly, comprising:

an elongated tapered bag having a first opening for receiving foodstuffs and a second
5 opening, smaller than said first opening, for dispensing said foodstuffs, said tapered bag being
obtained from a tubular foil made from at least one of the materials from the group consisting of
thermoplastic materials, such as Polyethylene (PE), Polypropylene (PP), Ethylene-vinyl acetate
(EVA), Polyvinyl chloride (PVC), or Polyamide (PA), PP or PE based thermoplastic elastomers
(TPE), and PP or PE based thermoplastic vulcanizates (TPV);

10 an elongated tapered nozzle having a dispensing end and a mounting end, wherein a cross
section of said nozzle near the mounting end is larger than the second opening; and

an elongated nozzle closing element that comprises a cavity for receiving the dispensing
end of the nozzle for closing said nozzle, wherein the nozzle closing element can be or is coupled
to said nozzle such that longitudinal axes of the nozzle and the nozzle closing element are
15 substantially parallel to each other;

wherein the nozzle closing element fits entirely through the second opening along its
longitudinal direction;

wherein the piping bag assembly can be assembled to form a closeable piping bag by
placing the nozzle and nozzle closing element, coupled to each other, through the second opening
20 via the first opening, and by subsequently fixing the nozzle near its mounting end in said tapered
bag by pulling said nozzle closing element;

wherein:

the tapered bag has a length in between 5 and 25 centimeter; and

the tapered nozzle has a length in between 1 and 5 centimeter; and

25 the dispensing end of the nozzle has an opening in between 0.05 and 0.25 centimeter,
more preferably in between 0.07 and 0.15 centimeter, and even more preferably in between 0.08
and 0.10 centimeter; and

the nozzle closing element has a length in between 1.0 and 4.0 centimeter.

30 2. The piping bag assembly according to claim 1, wherein at least one of the nozzle
and the nozzle closing element is made from flexible material allowing the nozzle and nozzle
closing element to be coupled to each other by first arranging the dispensing end in the cavity and
by subsequently rotating the nozzle and nozzle closing element relative to each other causing the
deformation of at least one of the nozzle and nozzle closing element; or

35 wherein the nozzle and the nozzle closing element may comprise mutually corresponding
screw threads.

3. The assembly according to claim 1 or 2, wherein a wall thickness of the dispensing end is below 0.02 centimeter.

5 4. The assembly according to claim 1, 2 or 3, wherein the nozzle comprises a mounting rim near its mounting end, said mounting rim preferably comprising a radially protruding circumferential edge.

10 5. The assembly according to claim 3, wherein a wall thickness of the nozzle is enlarged near the mounting rim.

6. The assembly according to claim 4 or 5, wherein said fixing the nozzle near its mounting end in said tapered bag comprises pulling on the nozzle closing element in a direction parallel to a longitudinal direction of the nozzle and away from the tapered bag to allow the mounting rim to firmly attach itself in a wall of the tapered bag.

7. The assembly according to any of the previous claims, wherein a region of the tapered bag near its second opening is complementary shaped to a region of the nozzle near its mounting end.

20

8. The assembly according to claim 7, wherein said region of the tapered bag near its second opening and said region of the nozzle near its mounting end are both cone shaped.

9. The assembly according to claim 7 or 8, wherein said region of the tapered bag near its second opening tapers according to a first tapering angle that is substantially equal to a tapering angle of said region of the nozzle near its mounting end.

25

10. The assembly according claim 9, wherein the first tapering angle is within the range from 5 to 15 degrees, preferably within the range from 7.5 to 12.5 degrees, and more preferably within the range from 9 to 11 degrees.

30

11. The assembly according to any of the previous claims, wherein the nozzle comprises two tapered elements that are fixedly connected to each other along the longitudinal direction of the nozzle, wherein the first element is tapered according to the first tapering angle, and wherein a tapering angle of the second element is smaller than the first tapering angle, said second element comprising said dispensing end.

35

12. The assembly according to claim 11, wherein the tapering angle of the second element is within the range from 0.5 to 5 degrees, preferably within the range from 1 to 3 degrees, and more preferably within the range from 1.5 to 2.5 degrees.

5

13. The assembly according to claim 11 or 12, wherein the first and second elements of the nozzle are cone shaped.

10

14. The assembly according to any of the previous claims, wherein the cavity is tapered and wherein a tapering angle of the cavity is substantially equal to a tapering angle of the nozzle near its dispensing end.

15

15. The assembly according to claim 14, wherein the cavity and the nozzle near its dispensing end are complementary shaped, preferably cone shaped.

20

16. The assembly according to any of the previous claims, wherein the nozzle closing element comprises two elements that are fixedly connected to each other along the longitudinal direction, wherein the cavity is accommodated in the first element, and wherein the second element is flattened along the longitudinal axis of the nozzle closing element.

25

17. The assembly according to any of the previous claims, wherein the nozzle closing element and the nozzle are two separate elements that can be coupled to each other by arranging the dispensing end of said nozzle in said cavity of said nozzle closing element.

30

18. The assembly according to any of the claims 1-16, wherein the nozzle closing element and the nozzle are fixedly connected to each other thereby forming a single element, said single element comprising a tearing line or perforation line along which the nozzle closing element and nozzle can be separated, wherein the cavity is arranged in said nozzle closing element on a side opposite to the tearing or perforation line along the longitudinal direction of said nozzle closing element.

35

19. The assembly according to claim 18, wherein said single element is integrally manufactured.

20. The assembly according to any of the previous claims, wherein the nozzle and the nozzle closing element have been formed by injection molding.

21. The assembly according to any of the previous claims, wherein the nozzle and/or nozzle closing element is made from at least one of the materials from the group consisting of thermoplastic materials, such as Polyethylene (PE), Polypropylene (PP), Polycarbonate, Ethylene-
5 vinyl acetate (EVA), Polyvinyl chloride (PVC), Acrylate, Acrylonitrile butadiene styrene (ABS), Styrene-butadiene (SB), or Polyamide (PA), PP or PE based thermoplastic elastomers (TPE), and PP or PE based thermoplastic vulcanizates (TPV).

22. The assembly according to claim 20 and 21, wherein the nozzle and nozzle closing
10 element have been formed by:

forming the nozzle by injection molding using a first material having a first color;

allowing the nozzle to at least partially solidify; and

forming the nozzle closing element by injection molding using a second material having a
second color around the dispensing end of the nozzle;

15 wherein the first and second materials are different and/or wherein the first and second colors are different.

23. A closing assembly for closing a tapered bag, comprising the nozzle and the
nozzle closing element as defined in any of the previous claims.

20

24. A piping bag, comprising a tapered bag, a nozzle, and a nozzle closing element as
defined in any of the previous claims, wherein the nozzle is fixed in the tapered bag, and wherein
the nozzle closing element closes the nozzle.

25. The piping bag according to claim 24, said bag holding foodstuffs, wherein the
tapered bag is sealed near its first opening.

25

26. A method for manufacturing a piping bag, comprising:

providing the assembly as defined in any of the claims 1-22;

30 coupling the nozzle and the nozzle closing element if provided as separate elements;

placing the coupled nozzle and nozzle closing element through the second opening via the
first opening;

fixing the nozzle near its mounting end in said tapered bag by pulling said nozzle closing
element.

35

1/6

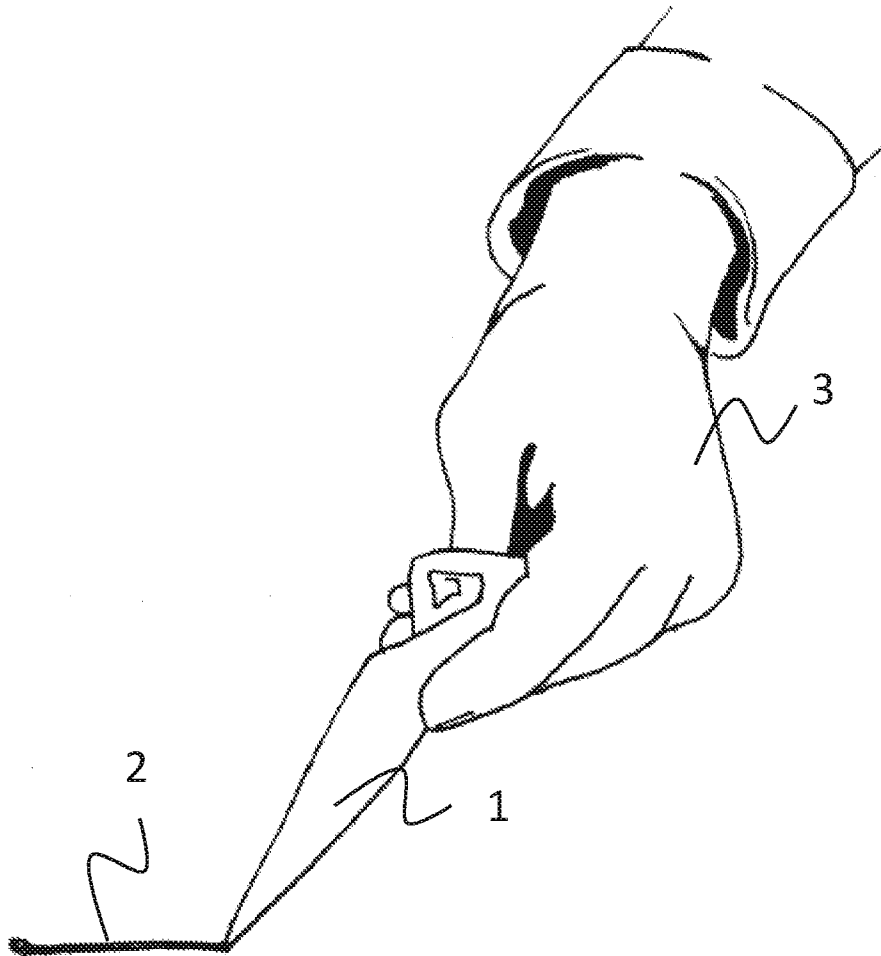

FIG. 1

2/6

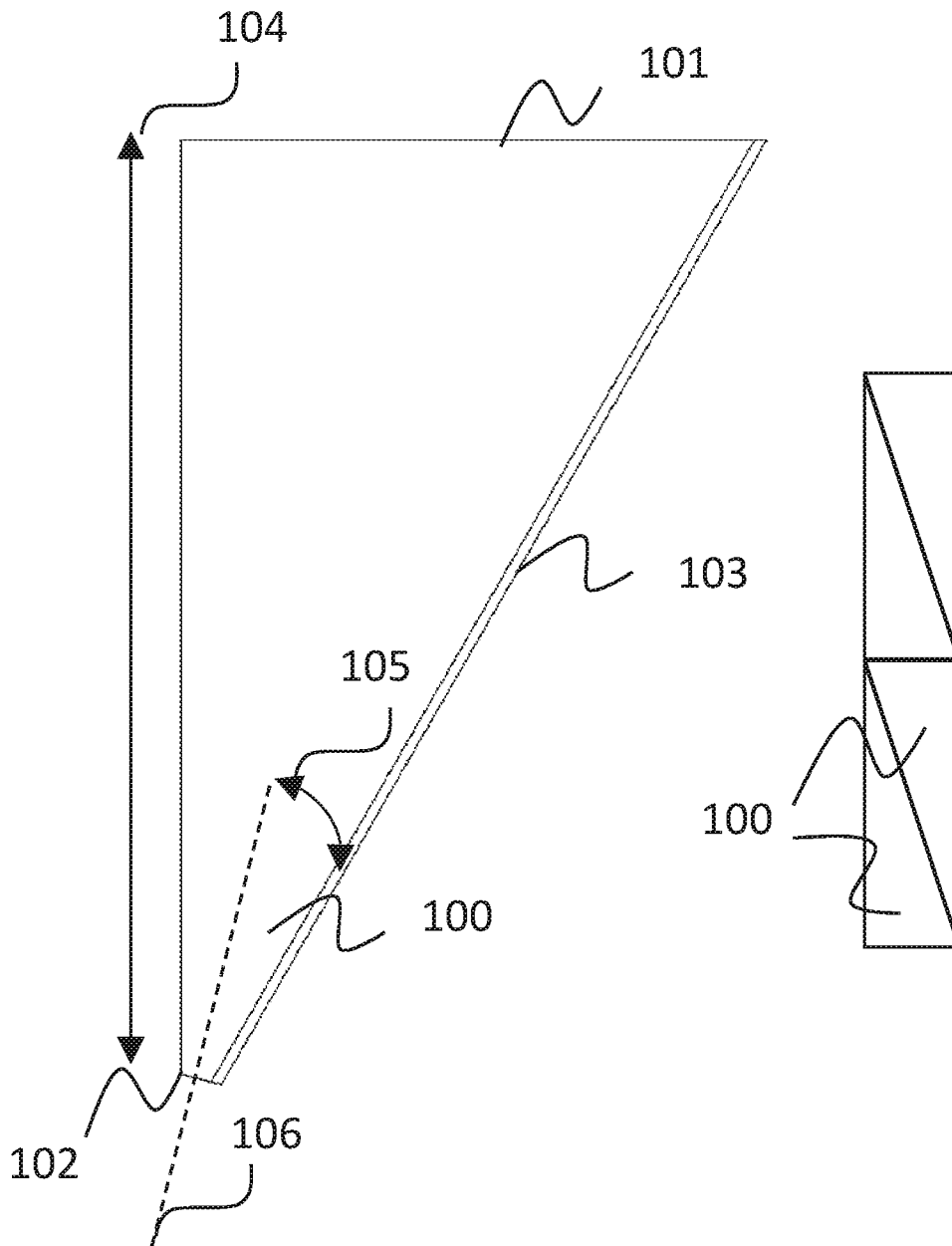

FIG. 2

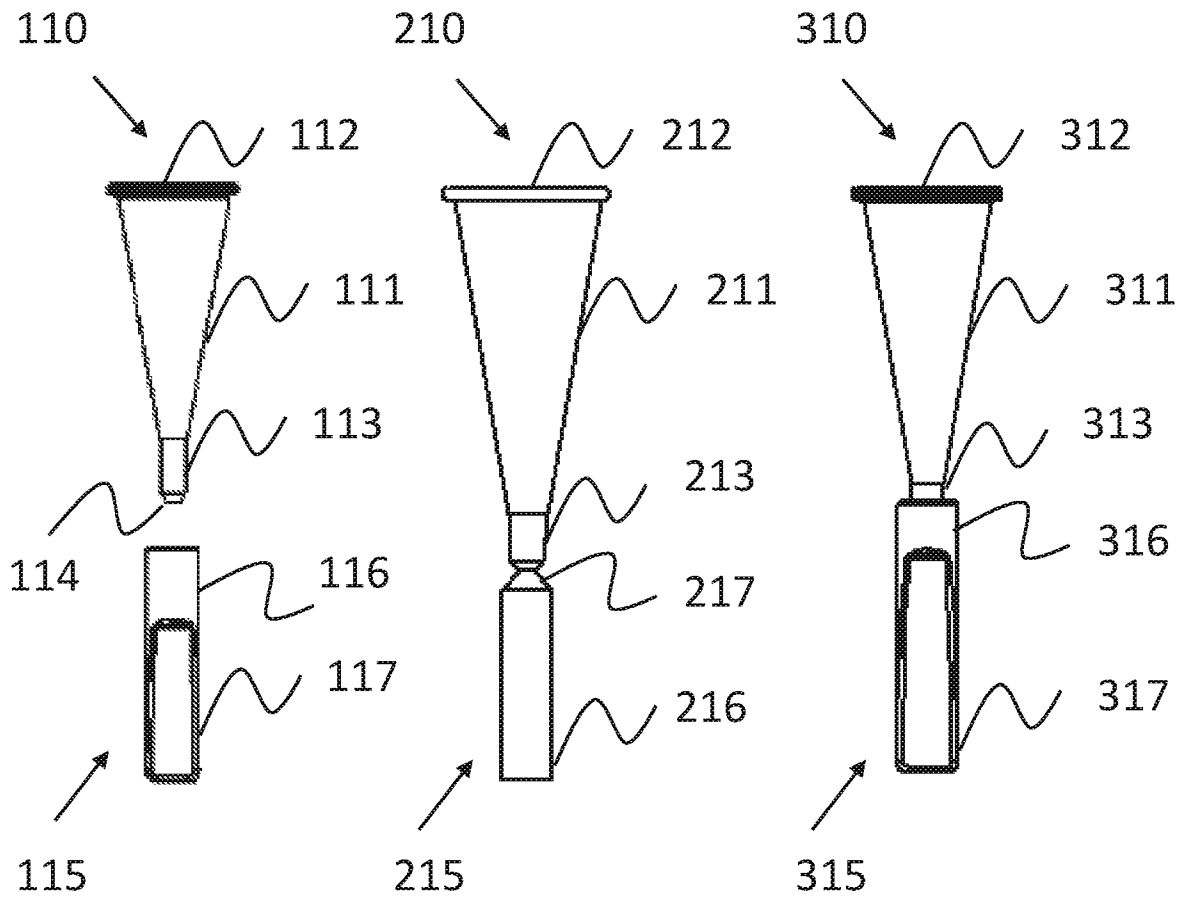

FIG. 3A

FIG. 3B

FIG. 3C

4/6

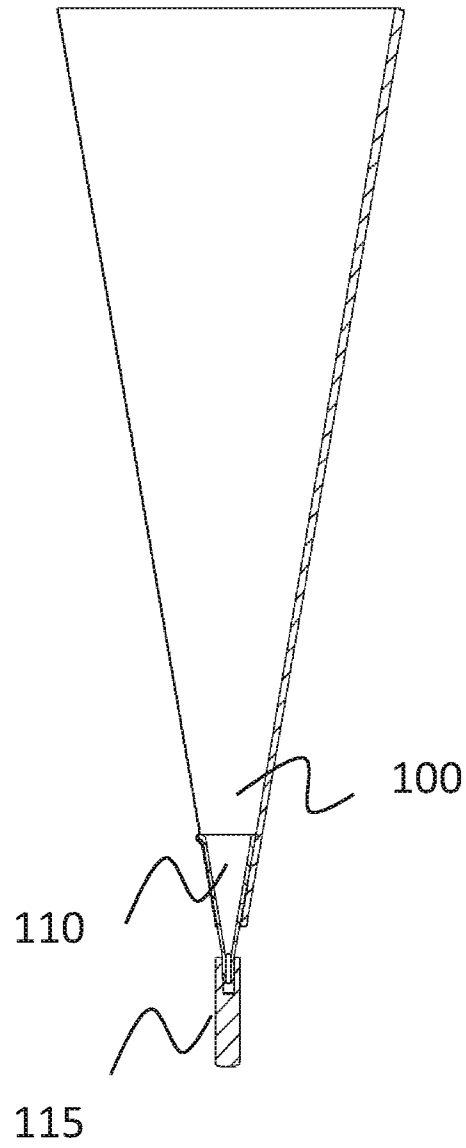

FIG. 4A

5/6

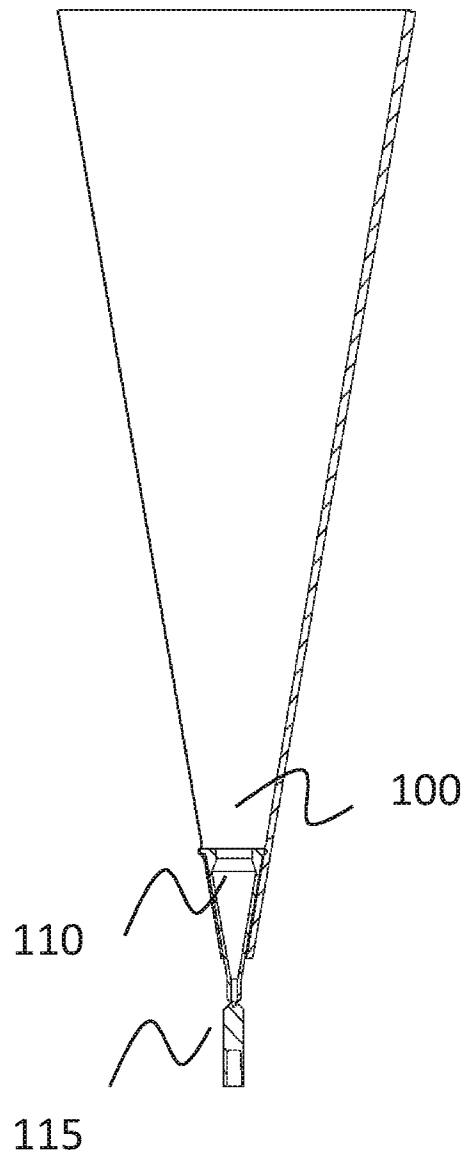

FIG. 4B

6/6

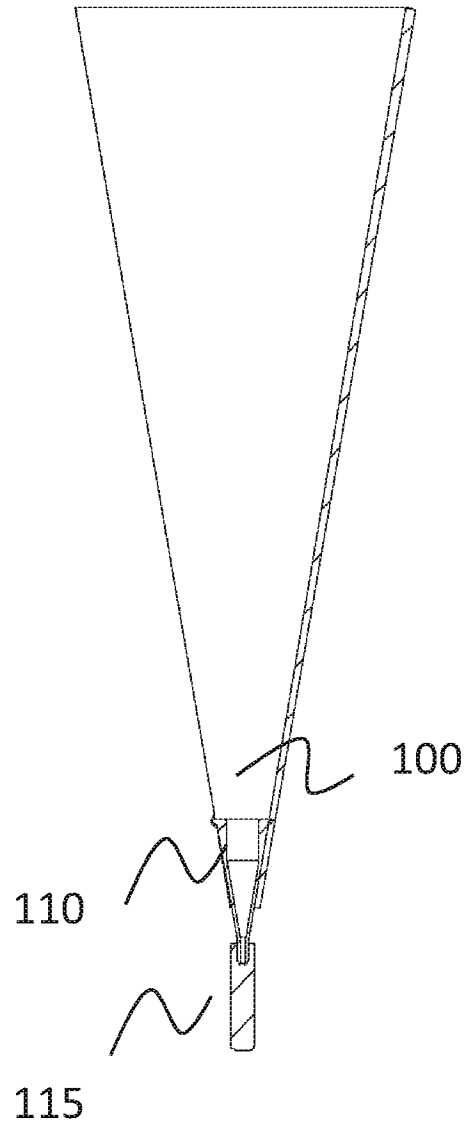

FIG. 4C