



Abstract

- 5 The innovation concerns components and their application in concrete components, in particular in shear stressed reinforced concrete components. Proposed are novel concrete components which, apart from the flexural reinforcement, also intend different types of shear reinforcements in the form of novel components which at least partially encircle the flexural reinforcement.

10

**Patent application****Inventor:**

5

Prof. Dr.-Ing. Gerd Günther  
Mittelweg 49  
D-63619 Bad Orb (DE)

10 **Asignee:**

Fachhochschule Gießen-Friedberg  
Wiesenstraße 14  
D-35390 Gießen (DE)

15

**REINFORCING ELEMENTS AND REINFORCED CONCRETE OR PRESTRESSED CONCRETE  
PARTS PRODUCED BY MEANS OF THE SAME**

20

The invention concerns a concrete reinforcement element according to the generic term used in Claim 1 as well as the reinforced concrete or pre-stressed concrete components made using this element according to the generic term used in Claim 30.

25

Shear stressed reinforced concrete or pre-stressed concrete components, such as a supported reinforced concrete ceiling, require shear reinforcement in the area of columns of the ceiling to ensure shear safety.

30

Known shear reinforcement includes the following: shear reinforcements made of concrete reinforcing steel with shear reinforcement elements in the form of S-hooks (although this is no longer allowed according to DIN 1045) or stirrups, dowel bars, double headed dowels, open web girder, Tobler Walm, "Geilinger Kragen", retaining plate mesh, "Riss Stern", etc.

35

Shear reinforcement with reinforcement elements in the form of S-hooks or stirrups has to be encircled with a usually available flexural longitudinal reinforcement, due to bad anchorage in order to prevent the shear reinforcement being ripped out. It must be noted that this only achieves a moderate increase in the shear force resistance. The fitting of

40

the concrete reinforcement elements is complicated and thus costly. In addition, conventional concrete reinforcement elements, such as stirrups are no longer considered fittable if exposed to high degrees of concrete reinforcement and a high proportion of shear reinforcement.

5

The alternative option is to use dowel bars, which are usually put on the lower formwork, so that – if available – the lower layer of reinforcement is encircled by a cross-section of the bar. For the load bearing capacity, however, an exact positioning and fixing of the bar is crucial, which cannot always be ensured on a construction site. The dowel bars are furthermore individually made and welded, which in proportion to the very high costs brings hardly any demonstrable improvement of the shear force resistance.

10

Joining elements or spacers for the upper and lower layers of reinforcement are known from DE-U1-71 18 881, DE-U1-298 14 923, DE-OS-2 111 243 or DE-OS-1 913 104. These elements, however, do not serve as concrete reinforcement elements; instead they fix only the reinforcement bars intended within the concrete component in a desired location or position before pouring in the concrete. This has no influence on the punching shear strength or even on the lateral load-bearing capability of the concrete ceiling.

15

Other known concrete reinforcement elements such as double headed dowels, Tobler Walm and "Geilinger Kragen" can improve the load-bearing capability or the punching shear strength of reinforced concrete or pre-stressed concrete components, in particular in the area of ceiling support. However, the lateral load-bearing capability of the concrete component is also hardly influenced through their use. Furthermore, these elements which mostly have to be produced individually on site, are characterised by a very expensive production. They are also very time-consuming both in mounting and in production, and so much time is often not available on a construction site.

20

The task of the invention is to overcome these and further disadvantages of the technical state of the art, by providing concrete reinforcement elements to be mounted in reinforced concrete or pre-stressed concrete components, which have a simple structure and are cheap to produce. Furthermore the invention aims to achieve a good anchorage of the concrete reinforcement elements between the reinforcement bars, while keeping the mounting quick and uncomplicated to execute. The concrete reinforcement elements have to improve the stability of the finished reinforced concrete or pre-stressed concrete component, in particular increasing significantly the lateral load-bearing capability of the

30

35

component. The reinforced concrete or pre-stressed concrete component also has to be cheap to produce and easy to handle.

The main characteristics of the invention are listed in the characterising part of Claims 1, 5 27, 28, 29 and 30. Arrangements are the subject of Claims 2 to 26 and 31 to 43.

A concrete reinforcement element in the form of a bi-dimensional component, which joins together, with a continuity of strength, the upper and lower layers of the reinforcement, located on the surface of the concrete component, with suitable upper and lower retaining 10 elements, forms the core of the invention. This significantly increases the shear force resistance of the reinforced concrete or pre-stressed concrete components.

The concrete reinforcement elements can be made as simple free-falling punched parts, to which further splays can be added if necessary. This enables a very cost-effective pro- 15 duction, which has a positive effect on the production costs for the concrete components.

The concrete reinforcement elements are easy to handle and quick to assemble. They simply have to be hooked in. No special knowledge or skills are required, as for example in the case of welding work. 20

The retaining elements can be realised as drilled holes, side recesses out of the bi-dimensional component and/or as splays, which encircle at least the innermost layers of each upper and lower layer of reinforcement in the case of there being more than one upper and more than one lower layer of reinforcement. 25

Surprisingly it was found that concrete reinforcement elements of this kind improve especially the shear force resistance, as well as the punching shear strength as compared to conventional structures, when they are mounted according to the invention interacting with the layers of reinforcement within a concrete component. 30

In addition to this surprising result, it was also found that a minimum thickness of the bi-dimensional components, of 1mm for example, was sufficient when using conventional structural steel, which has a very favourable effect on production costs.

Further traits, details and advantages of the invention arise from the text of the claims, as well as in the following description of execution examples by means of the illustrations. They show:

- 5 Fig. 1 a schematic side view of a concrete reinforcement element,
- Fig. 2 a schematic side view of another embodiment of a concrete reinforcement element,
- 10 Fig. 3 to 6 a schematic side view each of further embodiments of a concrete reinforcement element,
- Fig. 7 a schematic side view of a concrete reinforcement element with a securing means,
- 15 Fig. 8 a schematic side view of a concrete reinforcement element with a different embodiment for a securing means,
- Fig. 9 a schematic side view of a concrete reinforcement element with yet another embodiment for a securing means,
- 20 Fig. 10 to 15 a schematic side view each of further embodiments of a concrete reinforcement element,
- 25 Fig. 16 a schematic representation of a further embodiment of a concrete reinforcement element,
- Fig. 17 a schematic representation of a concrete reinforcement element with a indented bi-dimensional structure,
- 30 Fig. 18 two joined concrete reinforcement elements,
- Fig. 19 three joined concrete reinforcement elements,
- 35 Fig. 20 a different embodiment of two joined concrete reinforcement elements,
- Fig. 21 another different embodiment of two joined concrete reinforcement elements,
- 40 Fig. 22 a schematic sectional view of a concrete reinforcement element divided into two parts,
- Fig. 23 a schematic sectional view of a different embodiment of a concrete reinforcement element divided into two parts,
- 45 Fig. 24 yet another embodiment of a concrete reinforcement element divided into two parts,
- Fig. 25 a further variation of a concrete reinforcement element,
- 50

Fig. 26 a schematic representation of a reinforced concrete or pre-stressed concrete component,

5 The concrete reinforcement element which is generally called 10 in Fig. 1 is for use in the reinforced concrete or pre-stressed concrete component 1 (which is not represented here in any further detail). It has as its main part 12 a simple flat structure made of structural steel, which has a recess 30 each in its upper area 14 and its lower area 15. The recess is formed by a slot, which is open to the longitudinal edge 16 on the side of the bi-  
10 dimensional structure 12, which extends vertically from its longitudinal centre M.

Each recess 30 forms a retaining element 20 for the concrete reinforcement element S (which is also not shown here), in particular for a reinforcement bar of an upper and lower reinforcement layer Bo, Bu in the reinforced concrete or pre-stressed concrete component  
15 1 (see Fig. 26). These lie on each surface of the component (which is also not shown in any further detail here). They are formed by a least one inner layer Bo<sub>y</sub>, Bu<sub>y</sub> and at least one external layer Bo<sub>x</sub>, Bu<sub>x</sub>, which runs vertically to the inner layer.

During assembly, the bi-dimensional structure 12, with its side-opening recesses 30, is  
20 simply put on two reinforcement bars S of the inner layers Bo<sub>y</sub>, Bu<sub>y</sub>, lying directly on top of each other and running in the same direction. This means that each reinforcement bar is at least partially encircled. The clearance of the recesses 30 is calculated in such a manner that the bi-dimensional structure 12 with force transmission by friction sits tightly on the reinforcement bar S, so that it can not become loose while the concrete is poured  
25 in.

Hereby it is important that each concrete reinforcement element 10 always lies laterally to its bi-dimensional structure 12, and preferably vertically to the reinforcement bars S, extending, on the whole, over the thickness of the reinforced concrete or pre-stressed concrete component 1, namely to at least each upper and lower of the innermost of at least  
30 one inner layer Bo<sub>y</sub>, Bu<sub>y</sub> of the upper and lower reinforcement layers Bo, Bu. The latter are thereby bound together with a continuity of strength.

Comparative measurements have surprisingly shown that the concrete reinforcement  
35 element 10 according to the current invention significantly increases the punching shear strength as well as the shear force resistance of the reinforced concrete or pre-stressed concrete component 1 as compared to conventional constructions. It is sufficient here to

produce the bi-dimensional structure 12, using conventional structural steel, with a thickness of 1mm. This has a very favourable effect on material costs.

5 A further advantage of the concrete reinforcement element 10 is that due to its simple geometry it can be made, for example, as free falling punched parts, which further lowers production costs. They are quick and uncomplicated to mount and do not require any special knowledge or skills. This also leads to a considerable reduction in production costs for the reinforced concrete or pre-stressed concrete component 1.

10 In the embodiment of Fig. 2 the concrete reinforcement element 10 has as a retaining element 20 in the upper area 14 a slot 30, whereas a round or oval recess 30 is designated for the lower area 15.

15 The embodiment of Fig. 3 designates two slots 30 open on the side as retaining elements 20, which run diagonally to the top at an angle  $\alpha$  to the longitudinal centre M of the bi-dimensional structure 12. In contrast, the shape of Fig. 4 intends that the slots 30 run diagonally down at an angle  $\alpha$ . In both cases putting the concrete reinforcement element 10 on the reinforcement bars S is made easier, in particular within tight spaces.

20 The concrete reinforcement elements 10 represented in Fig. 5 has proven to have a particularly high increase in the lateral load-bearing capability of the reinforced concrete or pre-stressed concrete component 1. Here a total of four retaining elements 20 are designated for the upper and lower areas 14 and 15 of the bi-dimensional structure 12, namely two recesses 30 each, which are open to the longitudinal edge 16 and lie symmetrically to  
25 the longitudinal centre M.

Therefore, each concrete reinforcement element 10 covers in total four reinforcement bars S of the upper and lower reinforcement layers Bo, Bu, binding them together with continuing strength, which has a particularly positive effect on the lateral load-bearing capabilities of component 1. At the same time, each concrete reinforcement element 10 is  
30 firmly anchored between the reinforcement layers Bo, Bu. It can neither mistakenly fall out, nor can it slip when the concrete is poured in. The intervals and the positions of the reinforcement layers Bo, Bu are reliably secured at all times.

35 In order to further improve the fixing of the reinforcement bars S to the retaining elements 20 or in the recesses 30, the latter can have an extension 32 each up and down, so that

in the area of the longitudinal edges 16 of the concrete reinforcement element 10 notched edges 33 are formed for the reinforcement bars S.

5 The embodiment in Fig. 6 designates that the extensions 32 of the recess 30 in the upper area 14 of the bi-dimensional structure 12 lie across the longitudinal centre M, whereas the recess 30 in the lower area 15 is mainly L-shaped, namely with an upturned extension 32. Here one can see that the sub-area 31 of the recess 30, which is open to the longitudinal edge 16, has a lower clearance than the part of the recess 30 which lies in the longitudinal centre.

10

In order to further secure the reinforcement bars S of the upper and lower reinforcement layers Bo, Bu of the concrete reinforcement elements 10, the recesses 30 can be provided with a securing means 34. This can, for example, be a mainly U-shaped clip made of elastic material which can be reduced breadthwise by pressure on both of its outer  
15 legs, so that it can fit into the recess 30 (see Fig. 7). If the legs are released, they then lie within the walls of the slot 30 in the bi-dimensional structure 12, so that a reinforcement bar which lies in the recess 30 can not slip out sideways.

In the embodiment in Fig. 8 the securing means 34 consist of pins which are brought into  
20 the gable-end of the bi-dimensional structure 12 or onto the side mounted receptions 35. It is advantageous to use preferably brightly coloured indicatory agents, so that the insertion of a pin 34 can be easily marked and recognised on the construction site.

Alternatively a rotatable pin 34 or another rotatable bolting element, as well as a position-  
25 ing pin, can be arranged on the longitudinal edge 16 of the bi-dimensional structure 12, whereby the pin 34 is turned after the concrete reinforcement element S is brought in between the concrete reinforcement element 10 and the positioning pin. The indicatory agents 36 on the pin 34 would then show all in the same direction, or indicate the same inclination or position relative to the concrete reinforcement element 10, thus enabling a  
30 fast check of the secured condition even for a large number of concrete reinforcement elements.

Fig. 9 shows further advantageous embodiments for securing means 34, for example in the form of a simple elastic element, such as a strip or a simple wedge.

35

Another important embodiment of the concrete reinforcement element 10 according to this invention is shown in Fig. 10. The retaining element 20 is formed by an end-sided formed simple splay 40 in the upper area 14 of the bi-dimensional structure. Preferably this will encircle a reinforcement bar S of the outer layer Bo\_x of the upper reinforcement layer Bo (see Fig. 26, left element 10). The retaining element 20 in the lower area 15 of the bi-dimensional structure 12 is a L-shaped recess 30, which encircles a reinforcement bar S of the inner layer Bu\_y of the lower reinforcement layer Bu.

As shown by Fig. 11 to 13, the retaining elements 20 can be combined in almost any way in the form of recesses 30 and splays 40, whereby reinforcement bars S of the inner or outer layers Bo\_y, Bu\_y, Bo\_x, and Bu\_x can be grasped at the same time.

In Fig. 11a the splay 40 which is formed onto the upper area 14 is bent upwards, whereas the splay 40 in the lower area 15 points forward. The concrete reinforcement element 10 has thereby a mainly Z-shaped form in a cross-section– as can be seen in Fig. 11b, whereas the execution form of Fig. 12 and 12a has a U-profile in a cross-section.

According to Fig. 13a and 13b the splays 40 can be doubled or multiplied, whereby the concrete reinforcement element 10 can have an S-shape in the cross-section – as shown by Fig. 15b.

The embodiment of Fig. 16 is based on the construction form of Fig. 6, that means that in the upper and lower areas 14 and 15 of the bi-dimensional structure 12 a total of four recesses 30 are intended symmetrical to its longitudinal centre as retaining elements 20, which encircle the reinforcement bars with a continuity of form. The recesses 30 are not open to the longitudinal edges 16, that means that the reinforcement bars S are mainly introduced vertically into the bi-dimensional structure 12. Additional splays 40 encircle in each case the outer layer Bo\_x, Bu\_x of the upper and lower reinforcement layers Bo, Bu as additional retaining elements, so that the concrete reinforcement elements 10 are integrated in an optimal manner into the reinforced concrete or pre-stressed concrete component 1 for the purpose of increasing the lateral load-bearing capability. Furthermore, its ductility is also increased when there is strain on the shear force.

The same advantages are also found in yet another form of the concrete reinforcement element (Fig. 17). Here the bi-dimensional structure 12 is indented in the cross-section,

whereby the indentation 24, formed through simple and preferably right-angled splays, is realised between the upper and lower reinforcement layers (Bo, Bu).

5 If required, the concrete reinforcement elements 10 can encircle more than four reinforcement bars S. The bi-dimensional structure 12 must correspondingly be extended horizontally to its longitudinal centre M and the required number of retaining elements 20 must be added.

10 In the embodiment of Fig. 18 two concrete reinforcement elements 10 are arranged in longitudinal direction at least one reinforcement bar (S) next to each other in a V-shape, whereby the bi-dimensional structures in their upper areas 14 are joined to one another or are one piece.

15 The construction form of Fig. 19 provides for many concrete reinforcement elements 10 to be standing parallel one after the other. Each bi-dimensional structure 12 is bound in a T-shape with its upper area 14 to a flat bar 26, which protrudes over the breadth of the concrete reinforcement element 10 in order to at least partially hold or encircle an element S of the upper reinforcement layer.

20 The embodiment in Fig. 20 is made up of concrete reinforcement elements 10 and a flat bar 26, which together form a U-profile, whereby the latter also serves as a retaining element 20, in that it encircles at least one reinforcement bar S of the upper reinforcement layer Bo.

25 The recesses 30 in the upper area 14 of the bi-dimensional structure 12 can also be realised in a rectangular form – as shown by Fig. 21– and join two parallel concrete reinforcement elements 10, which are arranged next to each other, with a flexible spring clamp 28, whereby the clamp 28 with its legs (which are not described in any further detail) is set in the recesses 30, encircling also at least one reinforcement bar S of the upper  
30 reinforcement layer Bo.

Yet another important embodiment of the current invention can be seen in Fig. 22 to 24, when namely the bi-dimensional structure 12 of the concrete reinforcement element 10 is divided, vertically to its longitudinal centre M, into a lower half 50 and an upper half 60,  
35 whereby both halves 50 and 60 are joined to each other in a separable manner.

Thereby it is possible, for example, to prefabricate reinforced concrete or pre-stressed concrete components, for example ceiling elements in which the lower halves 50 of the concrete reinforcement elements 10 are built or poured into the lower half of the ceiling. Therefore, on the construction site, only the missing upper reinforcement layer Bo has to be added, whereby the upper halves 60 of the concrete reinforcement elements 10 are joined to the lower half 50 which is protruding from the prefabricated ceiling component. Afterwards, the ceiling can be completed by pouring in the concrete.

Ceiling elements which have been prefabricated in this way have the advantage of being much easier to handle and transport, as not only do they weigh less, but also the dimensions are smaller. Furthermore it also enables more flexible arrangement possibilities on the construction site. For example the thickness of the concrete ceiling can be individually designed, by using upper halves 60 with different lengths of the concrete reinforcement elements 10. Various retaining elements 20, in particular also splays 40, can be added to them in their final areas 14 and 15.

The halves 50 and 60 are preferably joined by means of the hook-shaped joining elements 52 and 62, which encircle one another with a continuity of strength and form. It is important here that the joint is constantly subjected to tension.

In the embodiment of Fig. 24 the lower half 50 of the concrete reinforcement element 10 is complemented by an upper half 60 made of coiled rods 66, whereby this is tilted in a Z-shape and can be put into an appropriate recess in the lower half 50.

Fig. 25 shows two views on the broad side of a further embodiment of the concrete reinforcement element 10 according to the current invention. This embodiment is characterised by the fact that the area between the broken lines compared to the areas above or below is shifted backwards or forwards from the image plane, going in or going out against the upper and lower area. This becomes visible when viewed on the narrow edge of both components. Alternatively, component 10 can also be realised in such a way, that, for example, only an upper part is shifted against a lower part of the component, for example, by tilting or stressing.

Herby, in both cases it is achieved that two such identical components 10, if they are pushed into each other with the edges 16, in which there are the openings of the side recesses 30, form a dovetail and a covered area comes into being, so that both compo-

nents 10 together form a recess 30, which secures an element S, which is threaded through it, of a reinforcement layer Bo or Bu from slipping upwards or downwards. The concrete reinforcement element 10 in the middle of Fig. 26 encircles per element S each of the outermost layers Bo\_x and Bu\_x of the upper and lower reinforcement layers Bo, Bu, while the concrete reinforcement element 10 represented on the right of Fig. 26 only joins elements S of the inner layers Bo\_y, Bu\_y of the upper and lower reinforcement layers Bo, Bu.

The number and embodiment of components 10 have to be calculated according to the type of concrete used and the desired load-bearing capability, in order to achieve the necessary punching shear strength, for example in the area of a column. In each case this results in a significant increase in the shear force resistance of the component 1.

The current invention is not limited to one of the aforementioned embodiments, but instead can be varied and altered in many different ways. The concrete reinforcement elements can, for example, be fabricated from other materials such as steel sheeting, plastic or composite material. One can also extend the concrete reinforcement elements 10 or their bi-dimensional structure 12 horizontally to their longitudinal centre M, in order to be able to encircle several reinforcement bars S of the upper and lower reinforcement layers Bo, Bu simultaneously. It is important here as well that the concrete reinforcement elements 10 are always simple, flat sheet metal components, if necessary tilted at the ends or in the middle, featuring retaining elements in the upper and lower areas which receive or encircle the reinforcement bars S of the upper and lower reinforcement layers Bo, Bu. Mounting is achieved without any complex welding or assembly work, whereby the upper and lower reinforcement layers Bo, Bu are pulled tight by the concrete reinforcement elements 10, joining them with a continuity of strength.

All of the traits and advantages in the claims, description and the illustrations, including constructive details, spatial arrangements and procedural steps can be essential to the current invention on their own or various different combinations.

### List of reference numerals

	$\alpha$	Angle
	Bo, Bu	Reinforcement layer
5	Bo_y, Bu_y	Inner layer
	Bo_x, Bu_x	Outer layer
	M	Longitudinal centre
	S	Concrete reinforcement element
10	1	Reinforced concrete or pre-stressed concrete component
	10	Concrete reinforcement element
	12	Main component
	14	Upper area
15	15	Lower area
	16	Longitudinal edge
	20	Retaining elements
	24	Indentation
	26	Flat bar
20	28	Clamp
	30	Recess
	31	Sub-area
	32	Extension
	33	Notched edge
25	34	Securing means
	35	Reception
	36	Marking
	40	Splay
	50	Lower half
30	52	Joining element
	60	Upper half
	62	Joining element
	66	Coiled rods

**Patent claims**

- 5 1. Concrete reinforcement element (10) for a reinforced concrete or pre-stressed concrete component (1), which features on the upper and lower surfaces of the component at least one reinforcement layer each (Bo, Bu), which is formed by at least one inner layer (Bo<sub>y</sub>, Bu<sub>y</sub>) and at least one outer layer (Bo<sub>x</sub>, Bu<sub>x</sub>), with a main component (12), which mainly covers the thickness of the reinforced concrete or pre-stressed concrete component (1) protruding at least above and below the innermost layer of at least one inner layer (Bo<sub>y</sub>, Bu<sub>y</sub>) of the upper and lower reinforcement layer (Bo, Bu), **whereby** the main component (12) is a bi-dimensional structure, featuring at least one retaining element (20) each in its upper area (14) and in its lower area (15), which is formed to encircle at least partially the circumference of a component of a concrete reinforcement element (S) of the upper and lower reinforcement layer (Bo, Bu).
- 10 2. Concrete reinforcement element according to Claim 1, **whereby** at least one retaining element (20) is a recess (30) formed within the bi-dimensional structure (12).
- 15 3. Concrete reinforcement element according to Claim 2, **whereby** the recess (30) is open to a longitudinal edge (16) of the bi-dimensional structure (12).
- 20 4. Concrete reinforcement element according to Claim 3, **whereby** the recess (30) runs vertically to the longitudinal centre (M) of the bi-dimensional structure (12).
- 25 5. Concrete reinforcement element according to Claim 3, **whereby** the recess (30) is at an angle ( $\alpha$ ) to the longitudinal centre (M) of the bi-dimensional structure (12).
- 30 6. Concrete reinforcement element according to one of the Claims 2 to 5, **whereby** the recess (30) lies approximately in the longitudinal centre (M) of the bi-dimensional structure (12) or extends this far.
- 35 7. Concrete reinforcement element according to one of the Claims 2 to 6, **whereby** at least two recesses (30) are formed within the bi-dimensional structure (12), which both lie symmetrically to its longitudinal centre (M).

8. Concrete reinforcement element according to one of the Claims 2 to 7, **whereby** the recess (30) is a slot.
- 5 9. Concrete reinforcement element according to one of the Claims 2 to 8, **whereby** the recess (30) along the longitudinal centre (M) features an extension (32) upwards and/or downwards.
- 10 10. Concrete reinforcement element according to one of the Claims 2 to 9, **whereby** the recess (30) features a securing means (34) in order to secure and/or fix the position of a, there to be inserted, concrete reinforcement element (S) of the upper and/or lower reinforcement layers (Bo, Bu).
- 15 11. Concrete reinforcement element according to Claim 10, **whereby** the securing means (34) can be inserted from the longitudinal edge (16) sideways into the recess (30).
- 20 12. Concrete reinforcement element according to Claim 10 or 11, **whereby** the securing means (34) is a wedge, an elastic clip or a pin inserted into a reception (35).
13. Concrete reinforcement element according to one of the Claims 10 to 12, **whereby** the securing means (34) carries a marking (36), in particular a coloured marking.
- 25 14. Concrete reinforcement element according to one of the Claims 1 to 13, **whereby** the bi-dimensional structure (12) is made of structural steel.
15. Concrete reinforcement element according to one of the Claims 1 to 14, **whereby** the bi-dimensional structure (12) features a thickness of at least 1 mm.
- 30 16. Concrete reinforcement element according to one of the Claims 1 to 15, **whereby** at least one retaining element (20) is a single or double splay (40) formed at the end side of the bi-dimensional structure (12).
- 35 17. Concrete reinforcement element according to one of the Claims 1 to 16, **whereby** the bi-dimensional structure (12) is indented in the cross-section.

18. Concrete reinforcement element according to Claim 17, **whereby** the indentation (24) is formed between the upper and the lower reinforcement layer (Bo, Bu).
- 5 19. Concrete reinforcement element according to one of the Claims 1 to 18, **whereby** at least two bi-dimensional bodies (12) are arranged next to each other in longitudinal direction of at least one concrete reinforcement element (S) of the upper and lower reinforcement layer (Bo, Bu).
- 10 20. Concrete reinforcement element according to Claim 19, **whereby** the at least two bi-dimensional bodies (12) are arranged in a V-shaped manner.
21. Concrete reinforcement element according to Claim 19, **whereby** at least two of the bi-dimensional bodies (12) are arranged mainly parallel to each other, joined by a flat bar (26).
- 15 22. Concrete reinforcement element according to Claim 19, **whereby** at least two of the bi-dimensional bodies (12) are arranged mainly parallel to each other, joined by a clamp (28).
- 20 23. Concrete reinforcement element according to one of the Claims 1 to 22, **whereby** the bi-dimensional structure (12) is divided, vertically to its longitudinal centre (M), into a lower half (50) and an upper half (60).
- 25 24. Concrete reinforcement element according to Claim 23, **whereby** the lower half (50) and the upper half (60) are joined to each other in a separable manner.
25. Concrete reinforcement element according to Claim 23 or 24, **whereby** the lower half (50) and the upper half (60) can be joined to each other with a continuity of strength and / or form.
- 30 26. Concrete reinforcement element according to one of the Claims 23 to 25, **whereby** the upper half (60) of the bi-dimensional structure (12) is made of S- shaped or Z- shaped coiled rods (66).

35

27. Concrete reinforcement element (10), preferably made out of structural steel, featuring at least one retaining element (20) in the upper and/or lower area (14, 15) of the concrete reinforcement element (10), **whereby** one retaining element (20) takes the form of a side recess (30), for the continuity of strength of reception of elements to be joined (S), such as reinforcement bars in concrete components (1), in particular according to at least one of the Claims 1 to 26, **whereby** the concrete reinforcement element (10) features a shift of the lower against the upper, or the middle area of the concrete reinforcement element (10) against the upper and lower area, when viewed at the narrow edge of the opening of the side recess (30), so that two of these same concrete reinforcement elements (10), when they are pushed on top of each other towards the side of the side recess, form a dovetail and that through a partial covering of both the side recesses (30) a hole is formed which reaches through both the concrete reinforcement elements (10), so that an element inserted through this to be joined to another element (S) is secured against slipping upwards or/and downwards.
28. Concrete reinforcement element (10), preferably made out of structural steel, featuring at least one retaining element (20) in the upper and/or lower area (14, 15) of the concrete reinforcement element (10), whereby one retaining element (20) takes the form of a side recess (30), for the continuity of strength of reception of elements to be joined (S), such as reinforcement bars in concrete components (1), in particular according to at least one of the Claims 1 to 26, **whereby** the concrete reinforcement element (10) features a shift of the left against the right or the middle area of the concrete reinforcement element (10) against the left and right areas, when viewed at the narrow upper or lower edge, so that two of these same concrete reinforcement elements (10), when they are pushed on top of each other from above or below over the narrow upper or lower edge, form a dovetail and that through a partial covering of both the side recesses (30) a hole is formed which reaches through both the concrete reinforcement elements (10), so that an element inserted through this to be joined to another element (S) is secured against slipping to the left or/and to the right.
29. Reinforced concrete or pre-stressed concrete component (1) with at least one concrete reinforcement element (10) according to one of the Claims 1 to 28.

30. Reinforced concrete or pre-stressed concrete component (1) which provides on the upper and lower surfaces of the component at least one reinforcement layer (Bo, Bu) as a flexural reinforcement consisting of several reinforcement bars (S) in x-direction (Bo\_x, Bu\_x) or/and in y-direction (Bo\_y, Bu\_y and Bo\_x, Bu\_x), whereby  
5 in order to increase the shear force resistance, at least one concrete reinforcement element (10) is provided as a bi-dimensional component, which extends basically over the thickness of the component to above and below of each of the innermost of the at least one uppermost or lowermost reinforcement layer each (Bo, Bu), in particular according to one of the Claims 1 to 28, **whereby** the bi-dimensional component (10) features at least one retaining element (20) each in its upper and lower  
10 area (14, 15), which is formed to encircle at least partially the circumference of a part of a element (S) of the at least one upper and lower reinforcement layer (Bo, Bu) or one of the additionally attached reinforcement bars, and therefore serves to join at least one element of the upper and the lower reinforcement layers with a continuity of strength.  
15
31. Concrete component according to Claim 30, **whereby** the bi-dimensional component (10) features a thickness of at least 1 mm, if it is realised by structural steel.
- 20 32. Concrete component according to Claim 30 or 31, **whereby** at least one of the upper or lower retaining elements (20) of the bi-dimensional component (10) is realised as a recess (30) formed out of the bi-dimensional structure (10, 12).
- 25 33. Concrete component according to Claim 30 to 32, **whereby** at least one of the upper or lower retaining elements (20) of the bi-dimensional component (10) is arranged in the form of a side recess (30), on one or both sides (16), extending from the lower to the upper reinforcement layer and takes the form of, for example, a slot.
- 30 34. Concrete component according to Claim 33, **whereby** the at least one side recess (30) of the bi-dimensional component (10) reaches approximately the centre (M) of the breadth of the bi-dimensional component (10).
- 35 35. Concrete component according to Claim 33 or 34, **whereby** the at least one side recess (30) of the bi-dimensional component runs from the side diagonally down or up, directed towards the upper or lower surface of the concrete component (10).

36. Concrete component according to Claim 33 to 35, **whereby** the at least one side recess (30) of the bi-dimensional component (10), features an upwards or/and downwards extension (32) of the recess at a fixed distance from the side opening, to ensure at least the partially arrested reception of an element (S) of the upper or lower reinforcement layer (Bo, Bu).
37. Concrete component according to Claim 33 to 36, **whereby** the at least one side recess (30) of the bi-dimensional component (10) features securing means (34) to secure the element (S), which has been inserted into the recess (30), of the upper or lower reinforcement layer (Bo, Bu) against slipping or sliding out of the recess (30).
38. Concrete component according to Claim 37, **whereby** the securing means (34) of the bi-dimensional component(10) are arranged in the form of:
- a wedge for the wedging of the opening of the at least one side recess (30) or
  - an elastic clip, which is stretched across the opening of the side recess (30) to prevent the necessary distortion being brought in, for example, in the shape of an elastic in normal condition stretched plastic strip or metal strip or
  - a system of drilling (35) in the component (10) arranged in the direction of the recess (30) at least through the leg, formed by the upper or lower limit of the component (10) and the opposite side of the recess (30), and if necessary, in addition, reaching into the part of the component (10) which lies opposite to the leg and the pin (34) which is to be inserted there, whereby the securing means (34) are realised preferably in bright colours or are joined with indicatory means (36) characterised by such colours in order to mark the secured condition.
39. Concrete component according to one of the Claims 30 to 38, **whereby** the bi-dimensional component (10), apart from a recess (30) features as a retaining element (20) a single or double splay (40) in order to encircle an element (S) of the upper or lower reinforcement layer (Bo, Bu) at the upper or lower end of the component (10).

40. Concrete component according to one of the Claims 30 to 39, **whereby** several components (10) according to the Claims 30 to 39 are intended, which are joined on their upper or/and lower part via a joint concrete reinforcement element (26), such as a bar or a flat bar.
- 5
41. Concrete component according to Claim 40, **whereby** the joint concrete reinforcement element (26) is intended as an additional concrete reinforcement element, below or/and above each of the outermost of the existing at least one upper or lower reinforcement layer (Bo, Bu) and in the case of there being more than one upper and lower reinforcement layers (Bo, Bu), it is also intended alternatively between the upper or/and lower layers.
- 10
42. Concrete component according to Claim 41, **whereby** the joint between the components (10) and the joint concrete reinforcement element (26) is realised as leading through the recesses (30) of the components (10) or as a welding, whereby in the case of a welding, the concrete reinforcement element (26) should preferably be realised as a flat bar or a flat metal sheet, which at least on the upper or lower side of the bi-dimensional component (10) protrudes over the edge which runs between the upper and lower reinforcement layer (Bo, Bu).
- 15
- 20
43. Concrete component according to Claims 30 to 42, **whereby** as bi-dimensional components (10) are intended those with a least one side recess (30), whereby the side recess (30) is preferably realised in the form of a slot leading to the upper or lower surface of the concrete component (1), and whereby the bi-dimensional components (10) when viewed from the side of the recesses show a shift of the lower against the upper or the centre area of the component (10) against the upper and lower areas, so that two of these same components (10), when they are pushed on top of each other towards the side of the side recess (30), form a dovetail and that through a complete covering of both, the side recesses (30) form a hole, which reaches through both the components (10), so that a concrete reinforcement element (S) inserted through this is secured against slipping upwards and/or downwards.
- 25
- 30

**Fetherstonhaugh  
Ottawa, Canada  
Patent Agents**

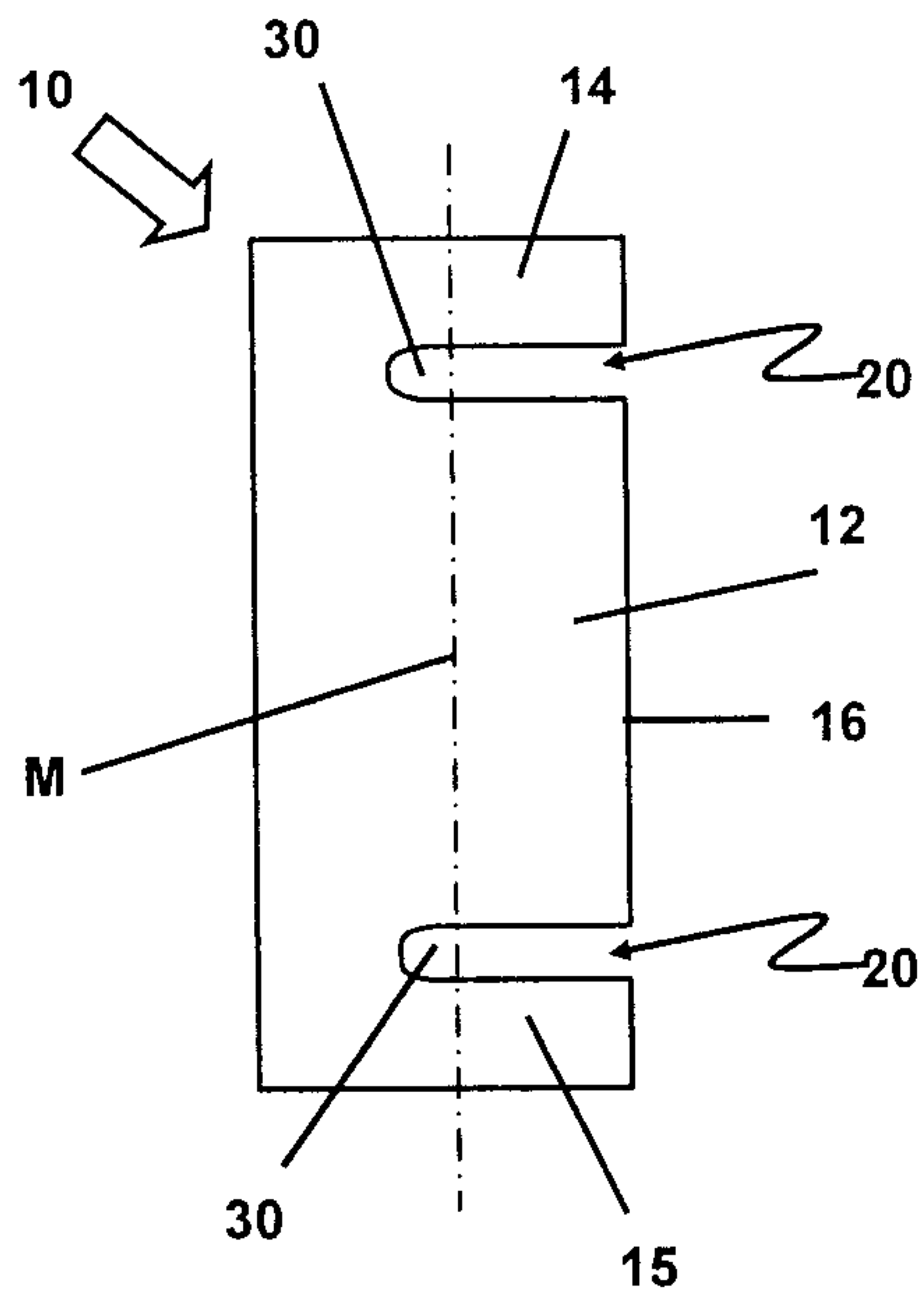

Fig. 1

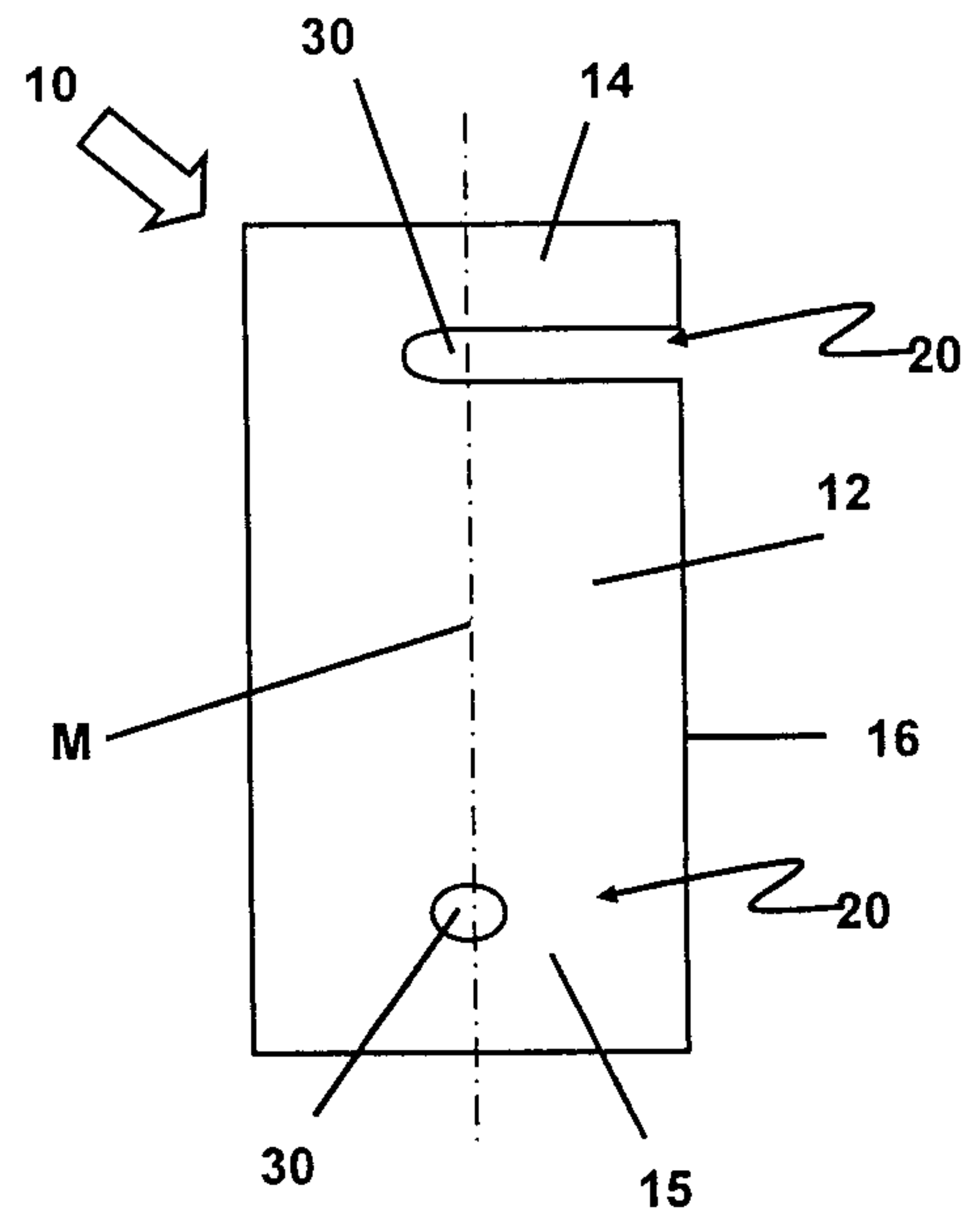

Fig. 2

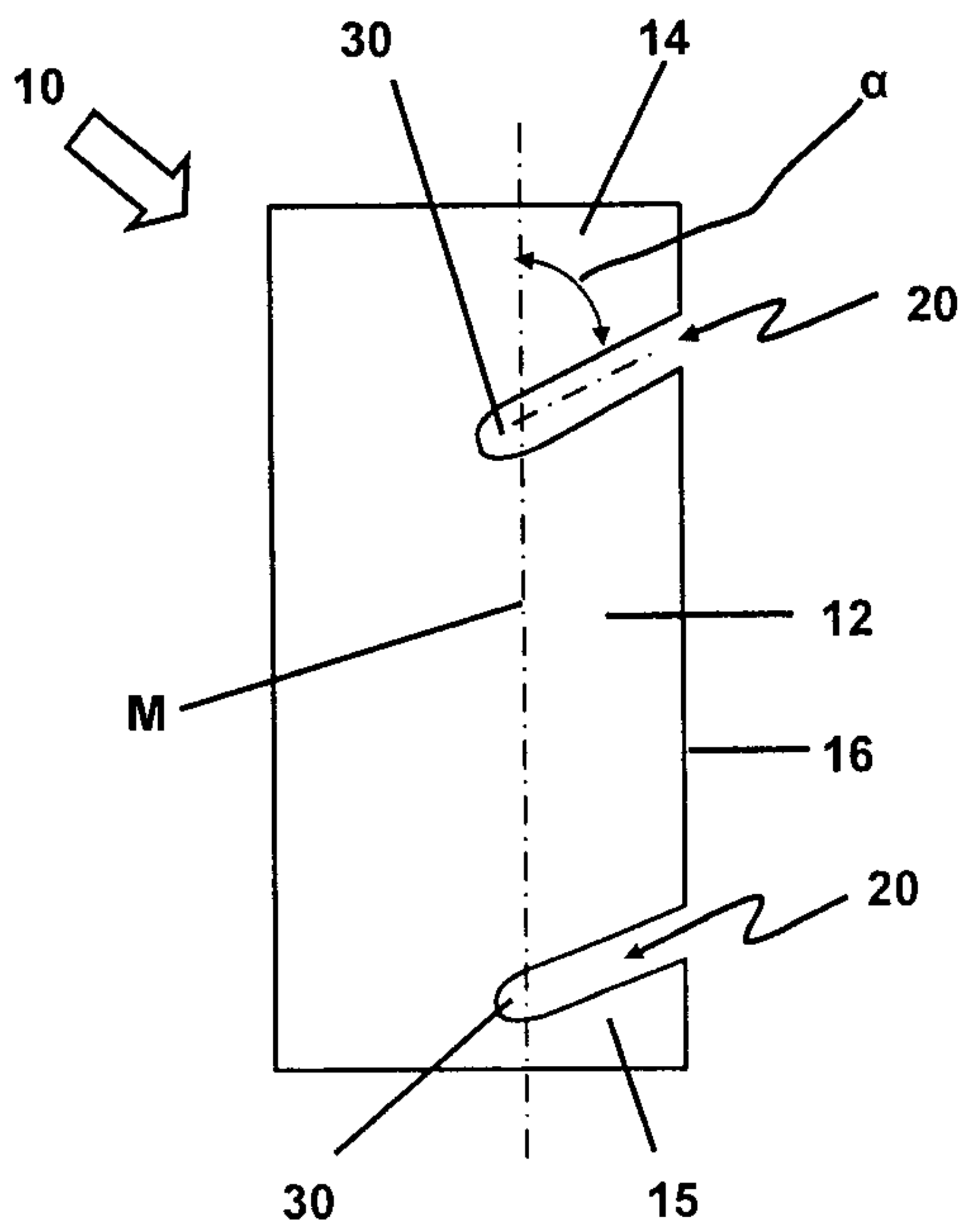

Fig. 3

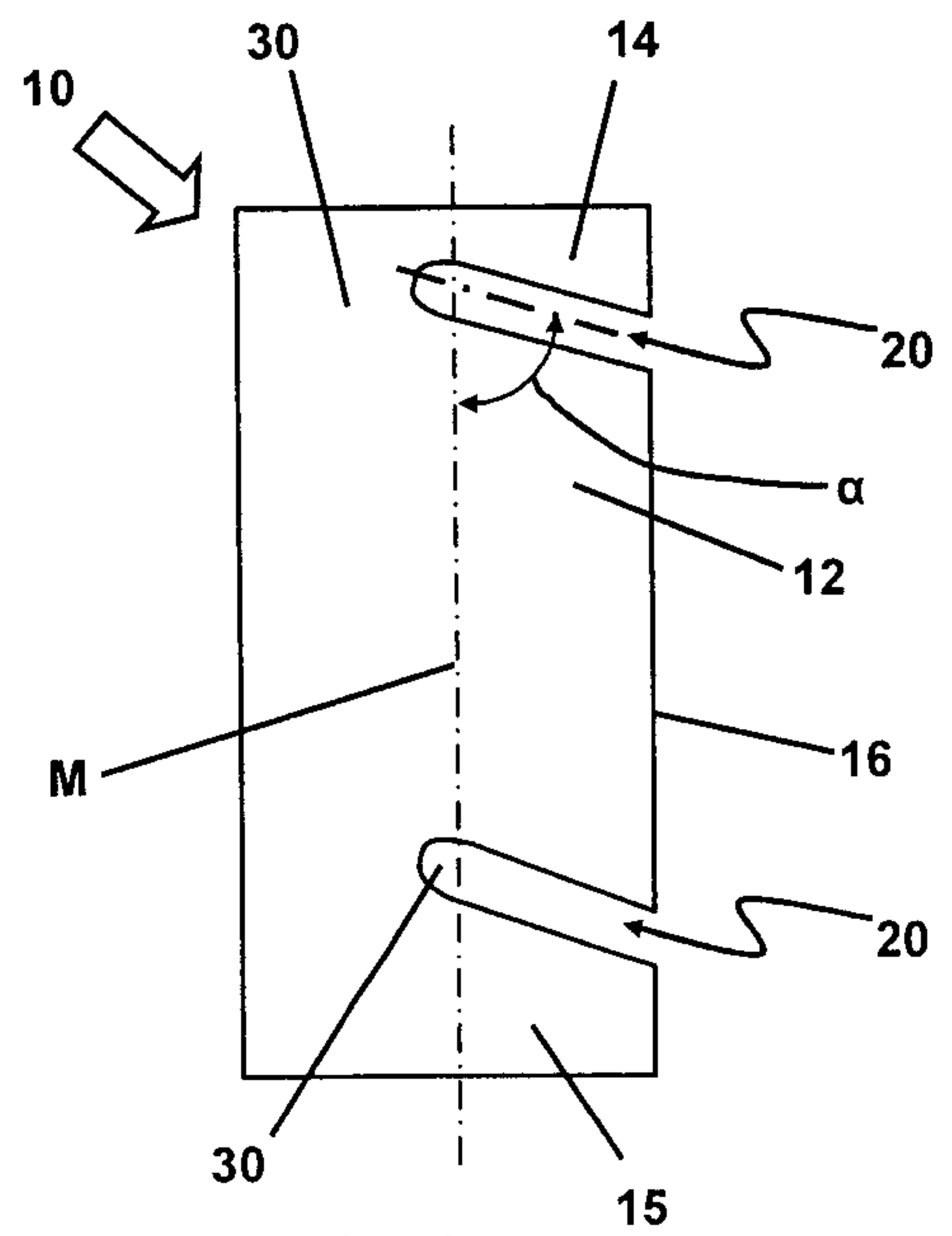

Fig. 4

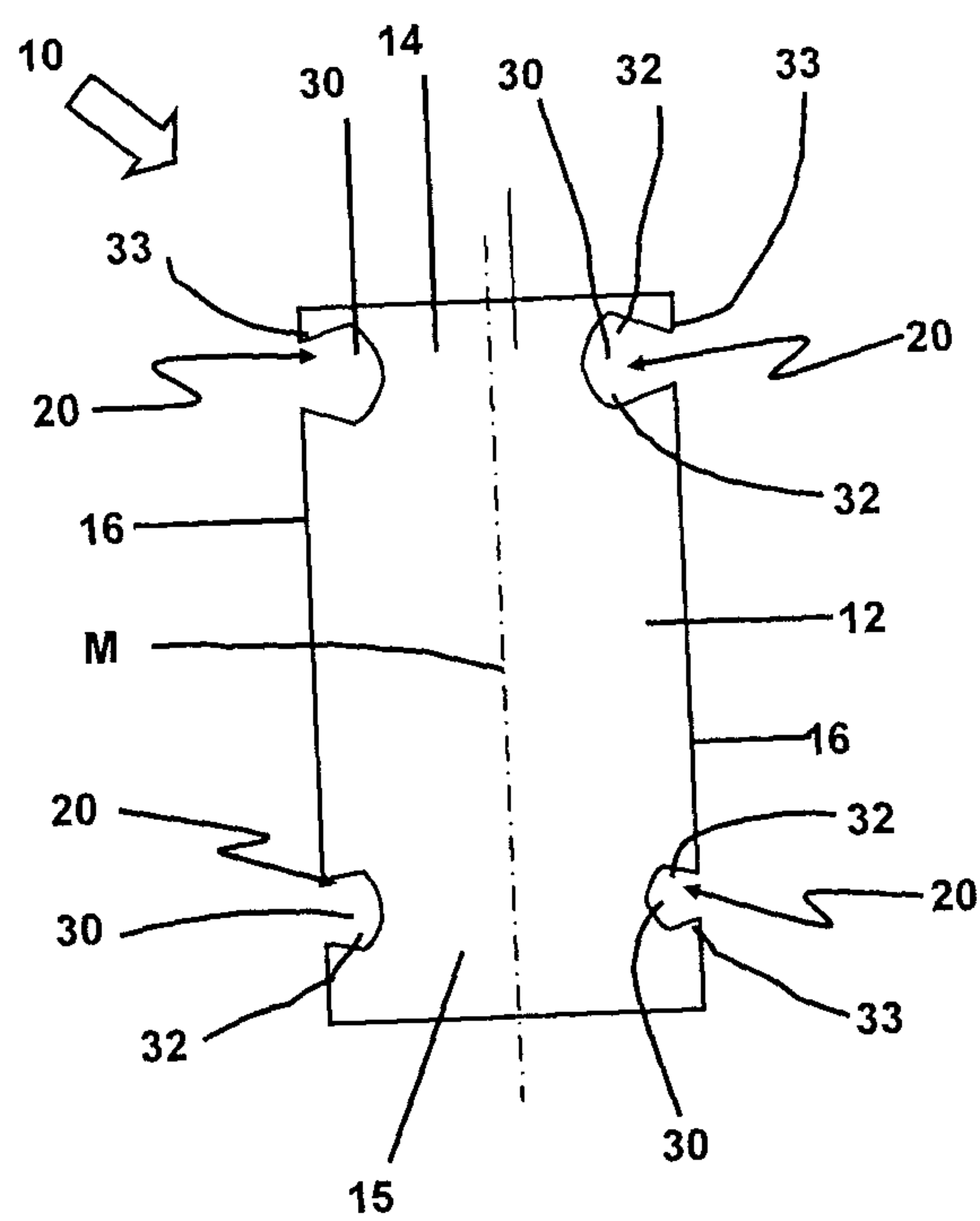

Fig. 5

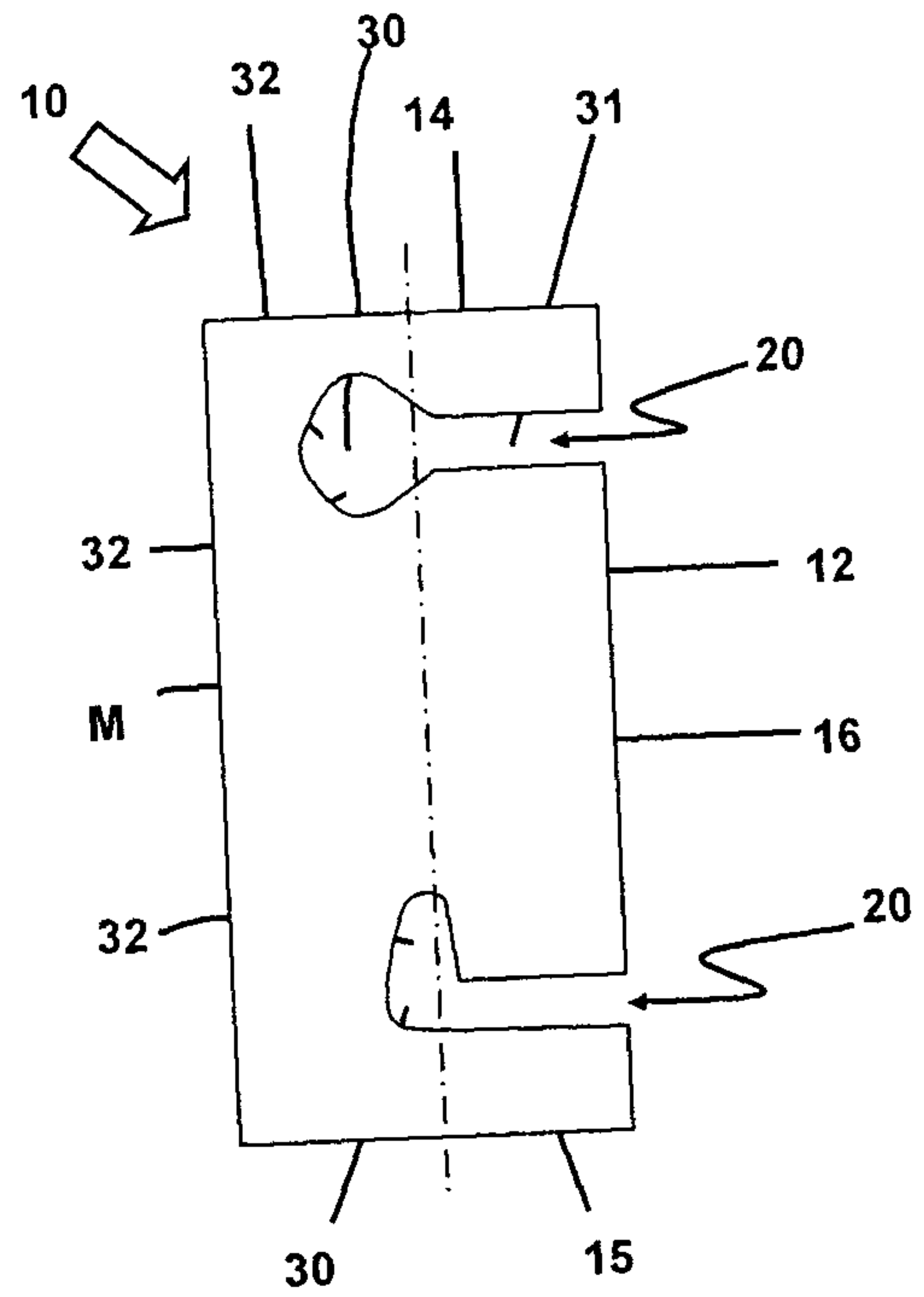

Fig. 6

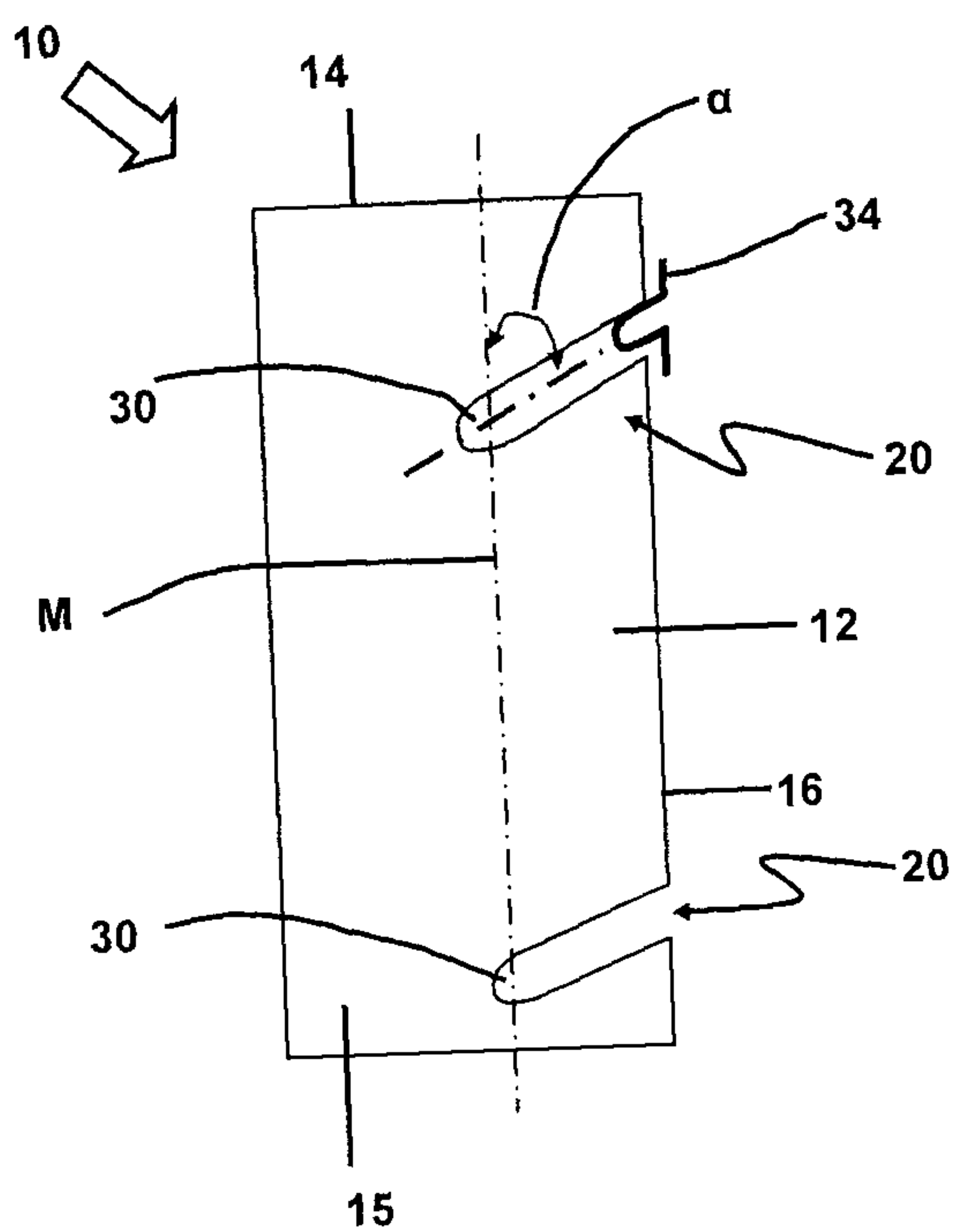

Fig. 7

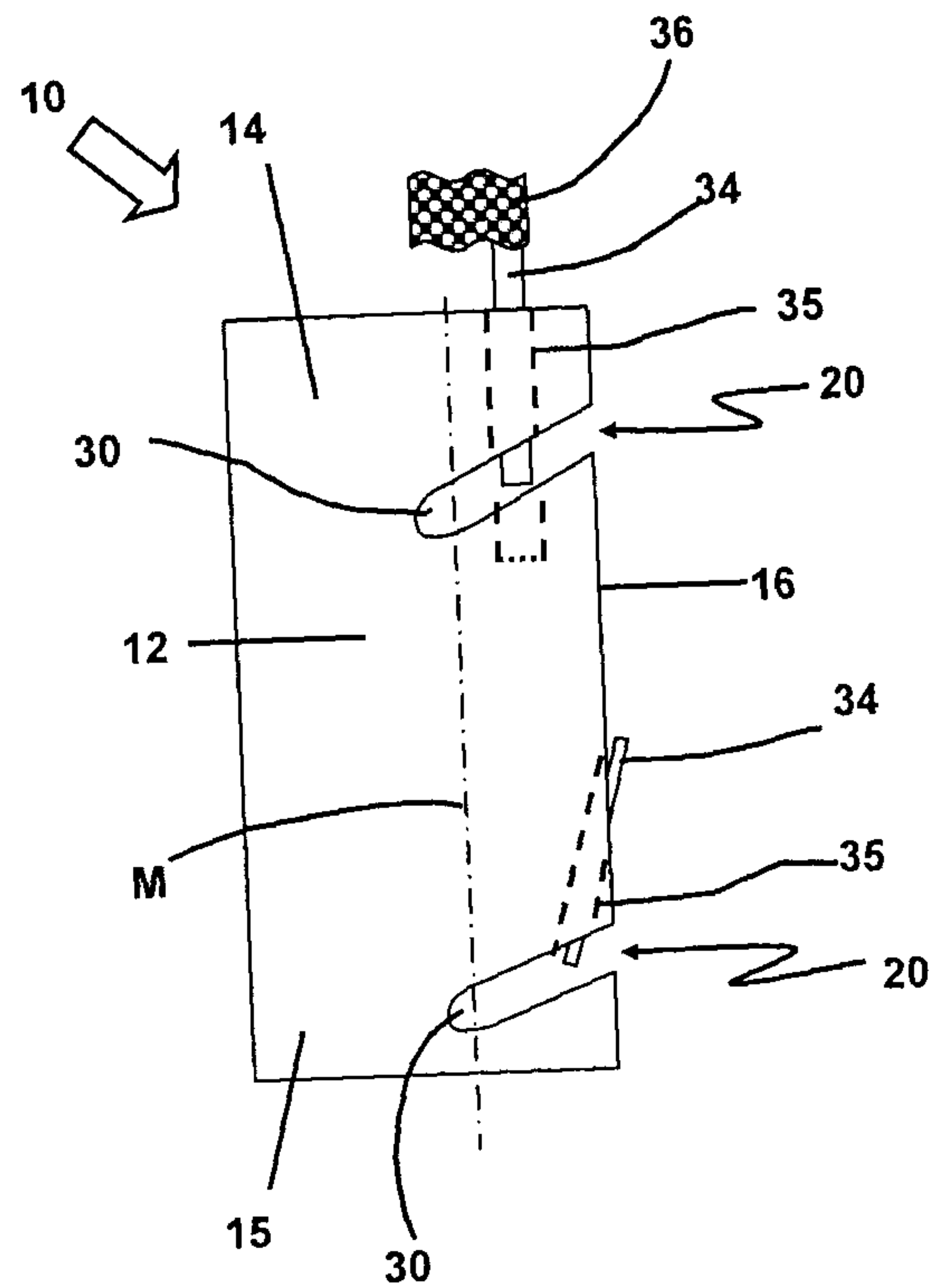

Fig. 8

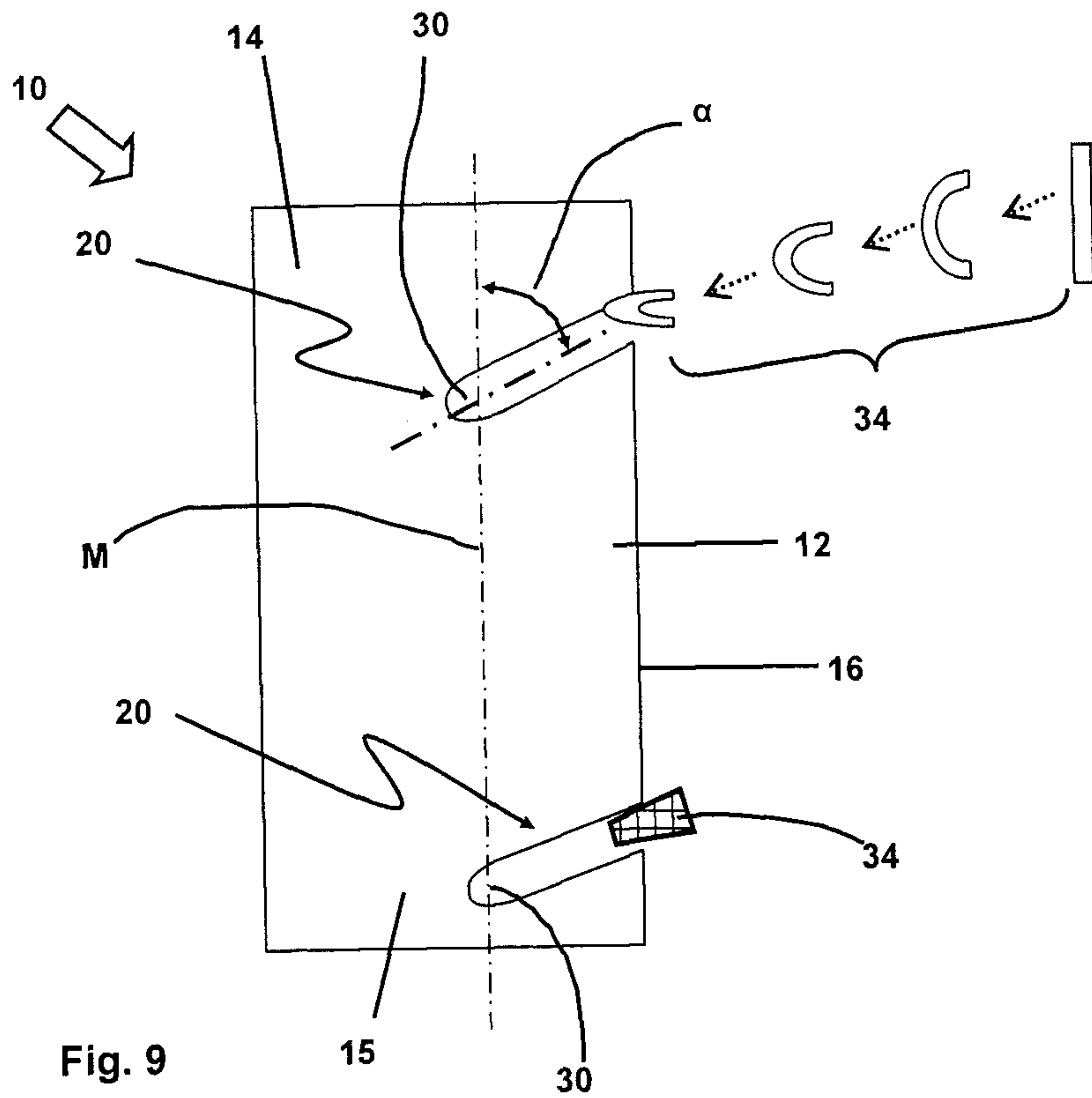

Fig. 9

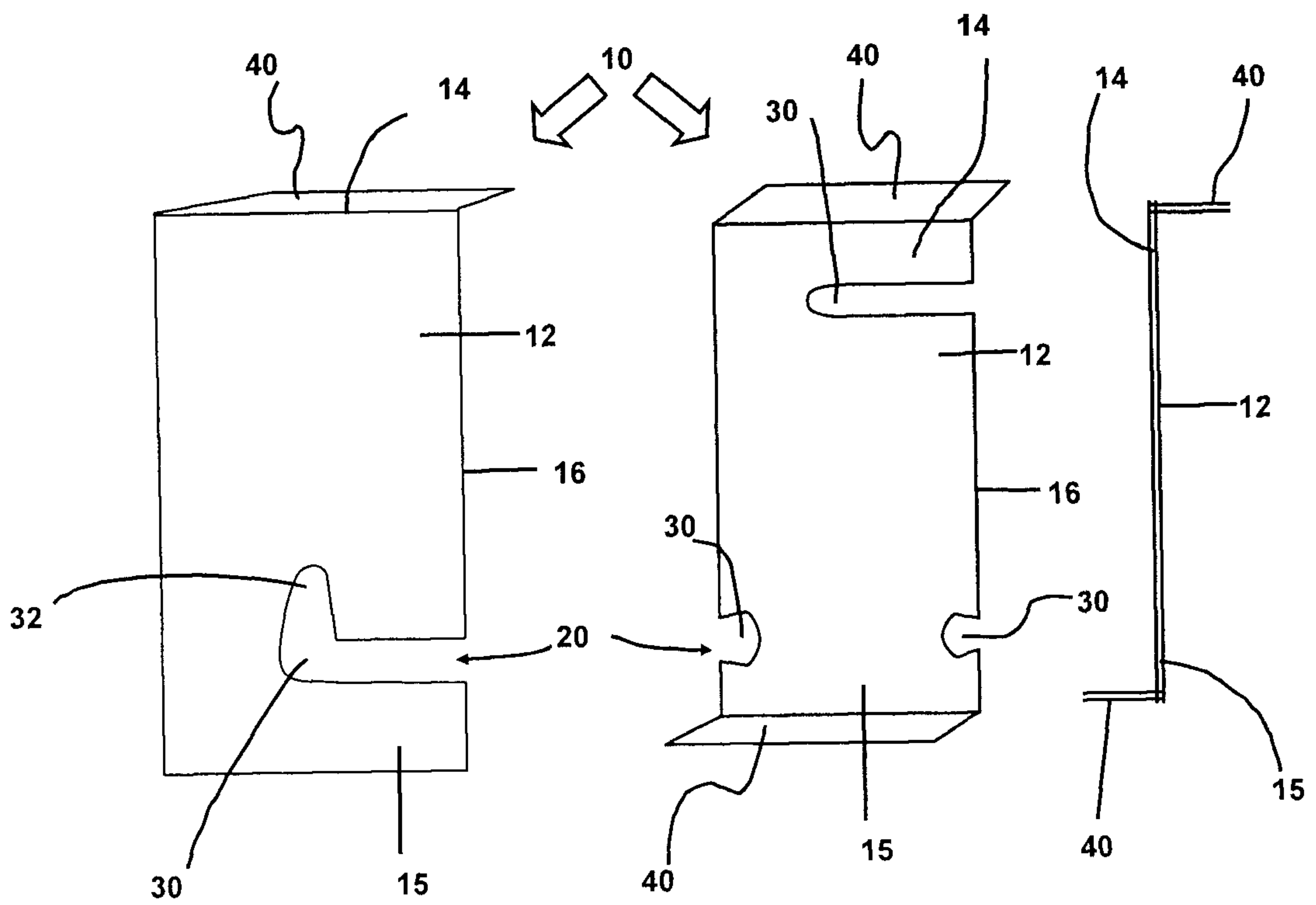

Fig. 10

Fig. 11a

Fig. 11b

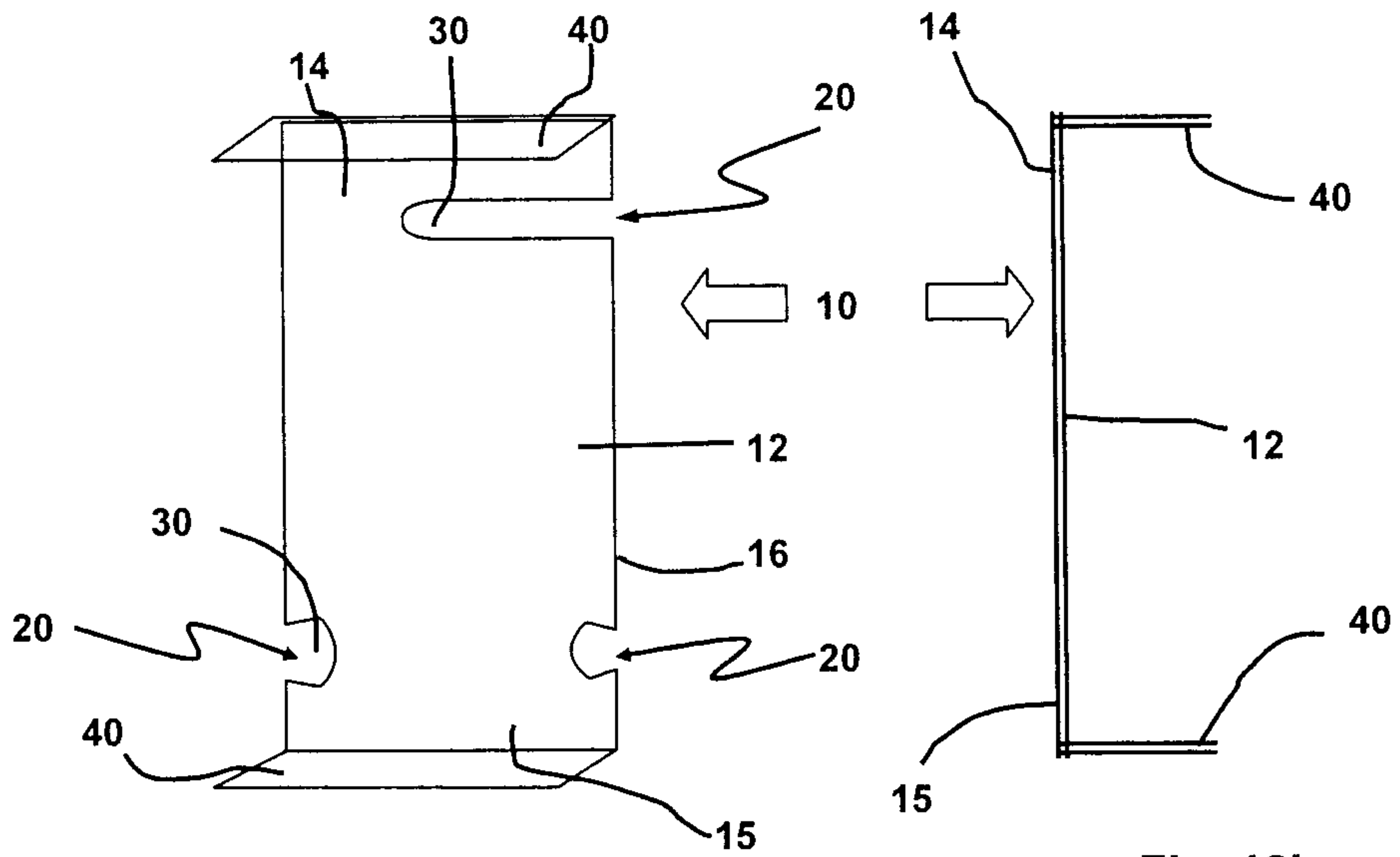

Fig. 12a

Fig. 12b

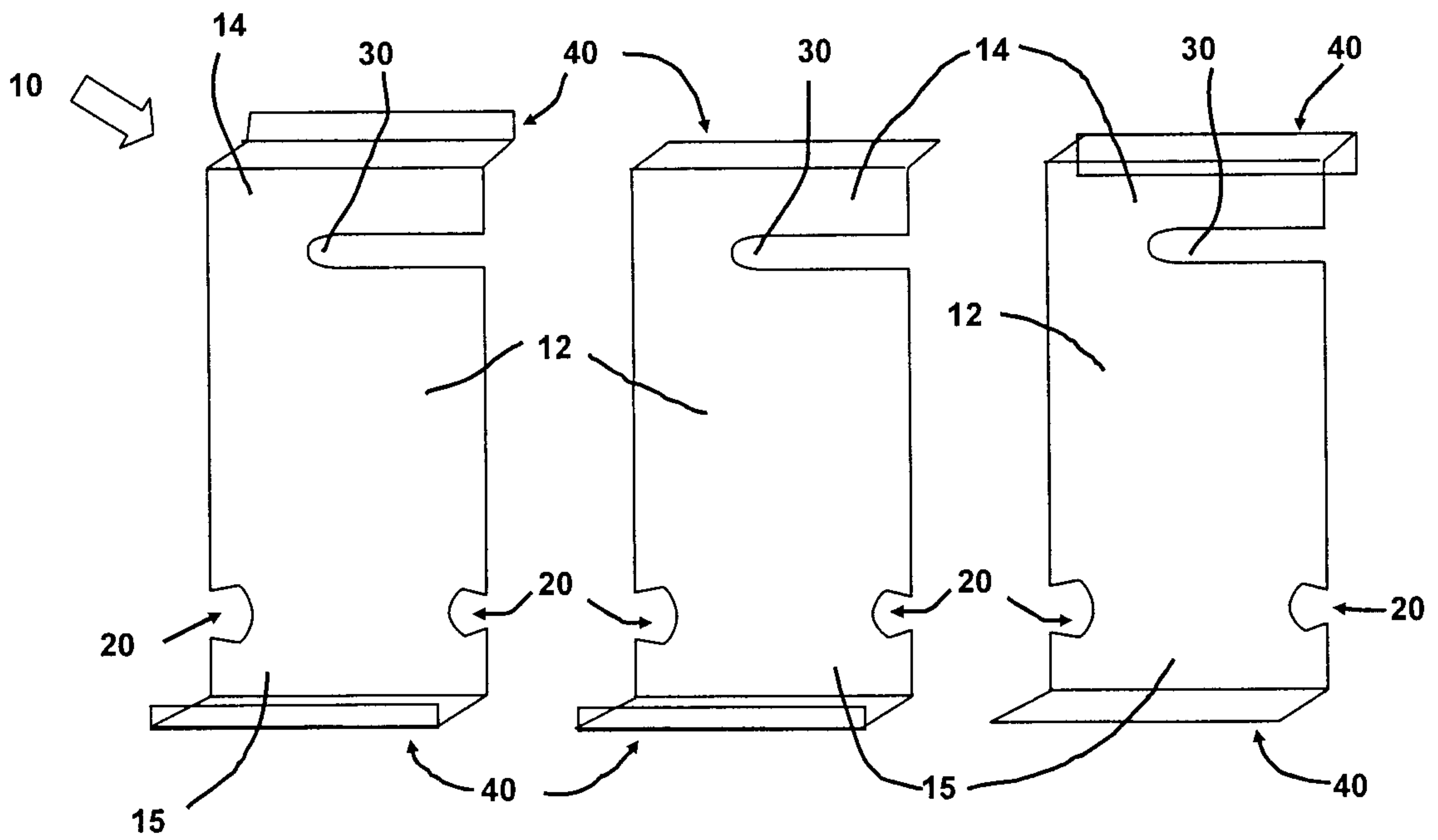

Fig. 13a

Fig. 14a

Fig. 15a

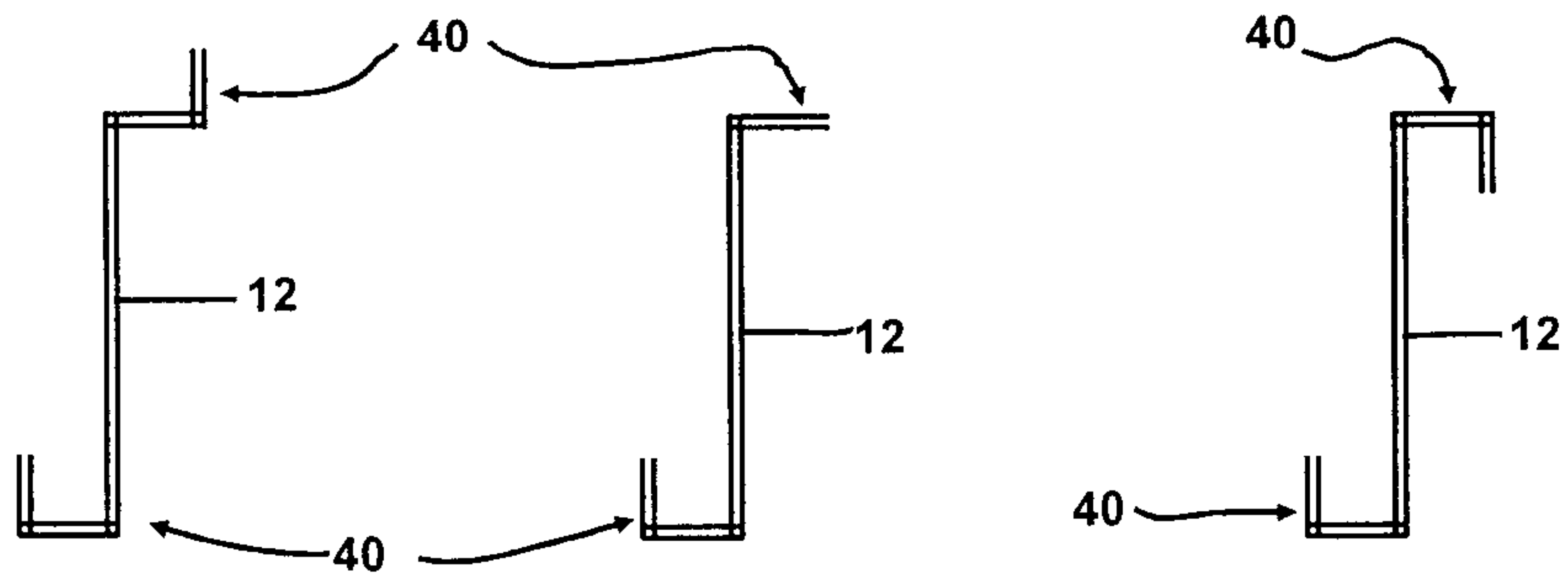

Fig. 13b

Fig. 14b

Fig. 15b

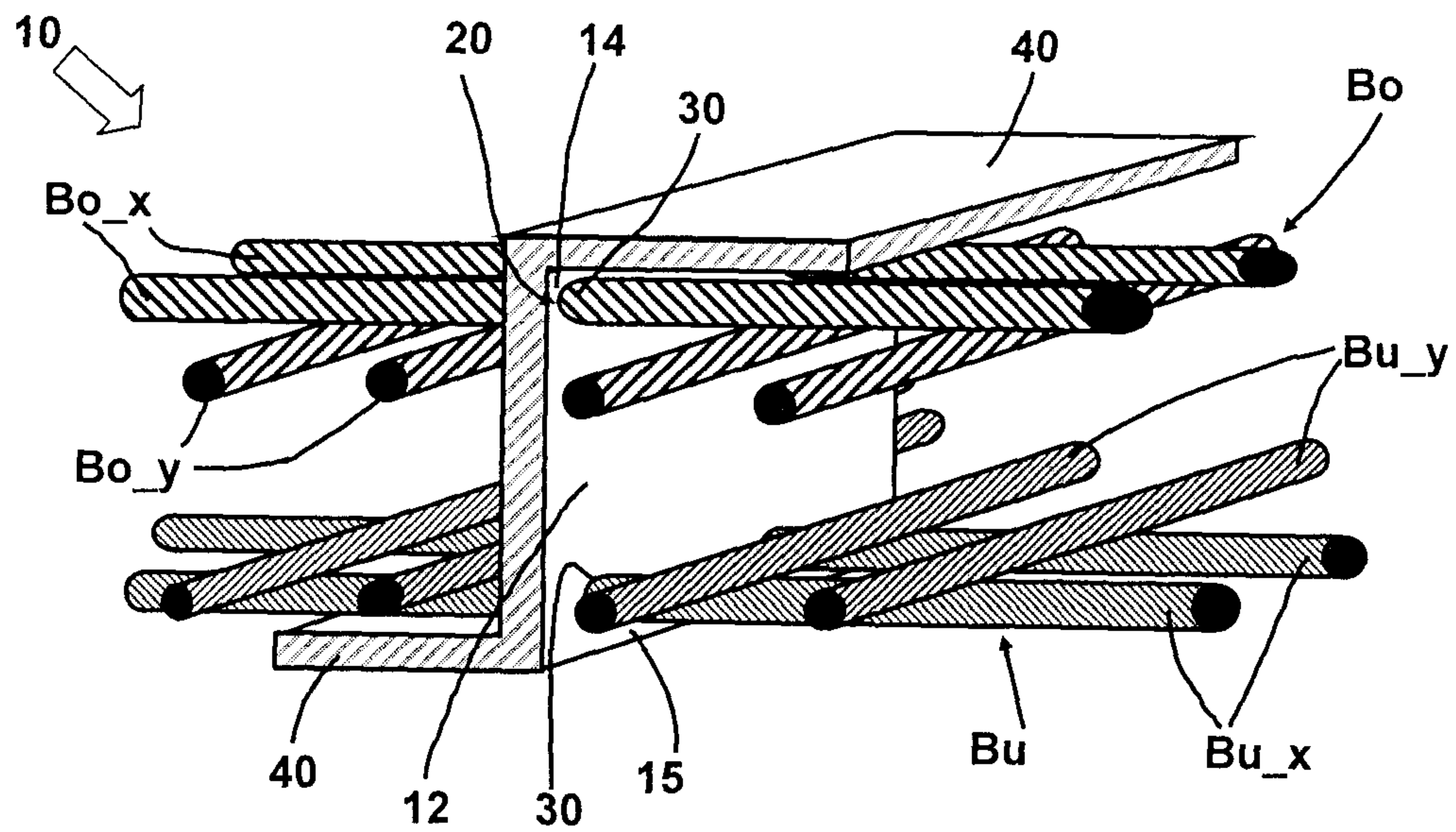

Fig. 16

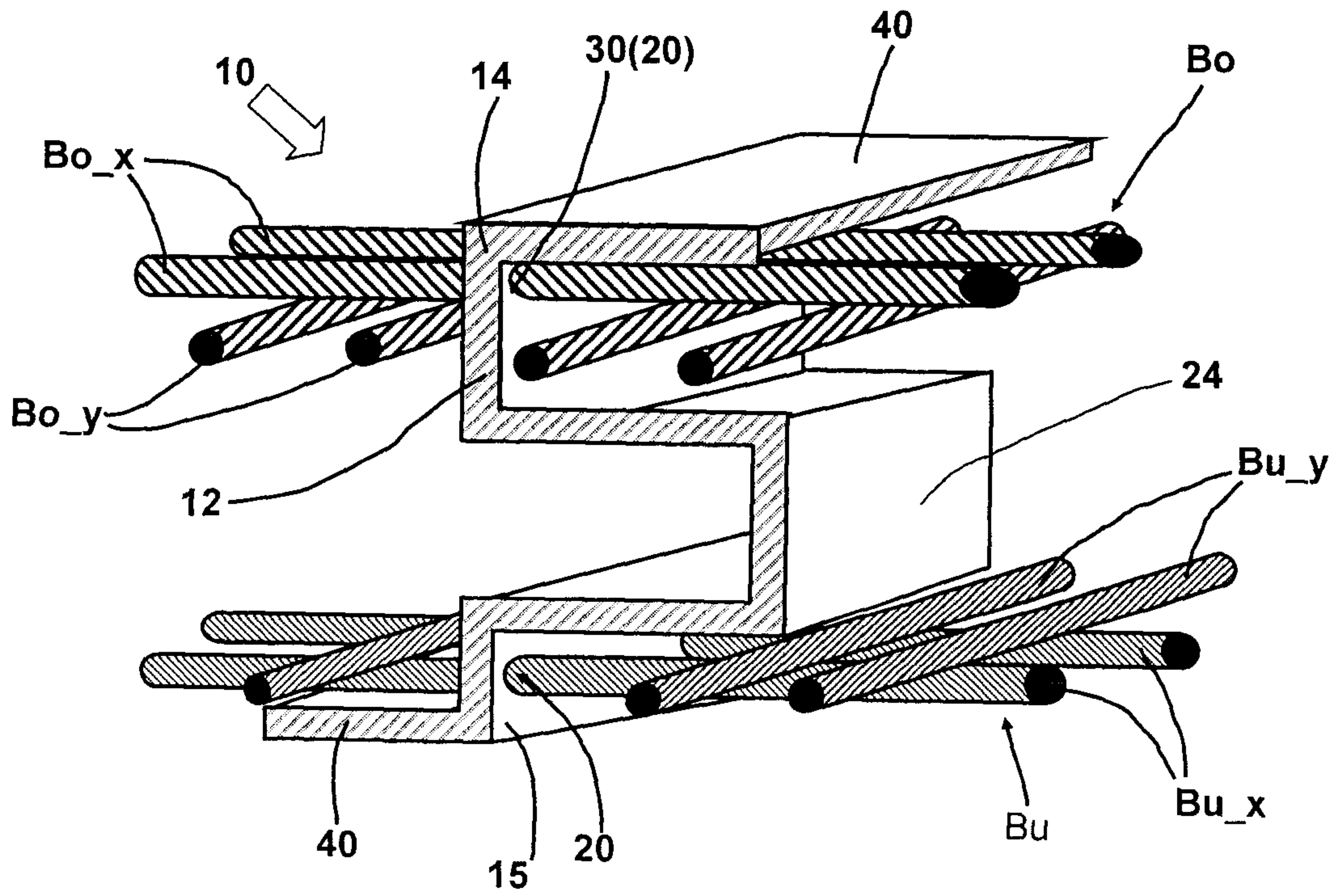

Fig. 17

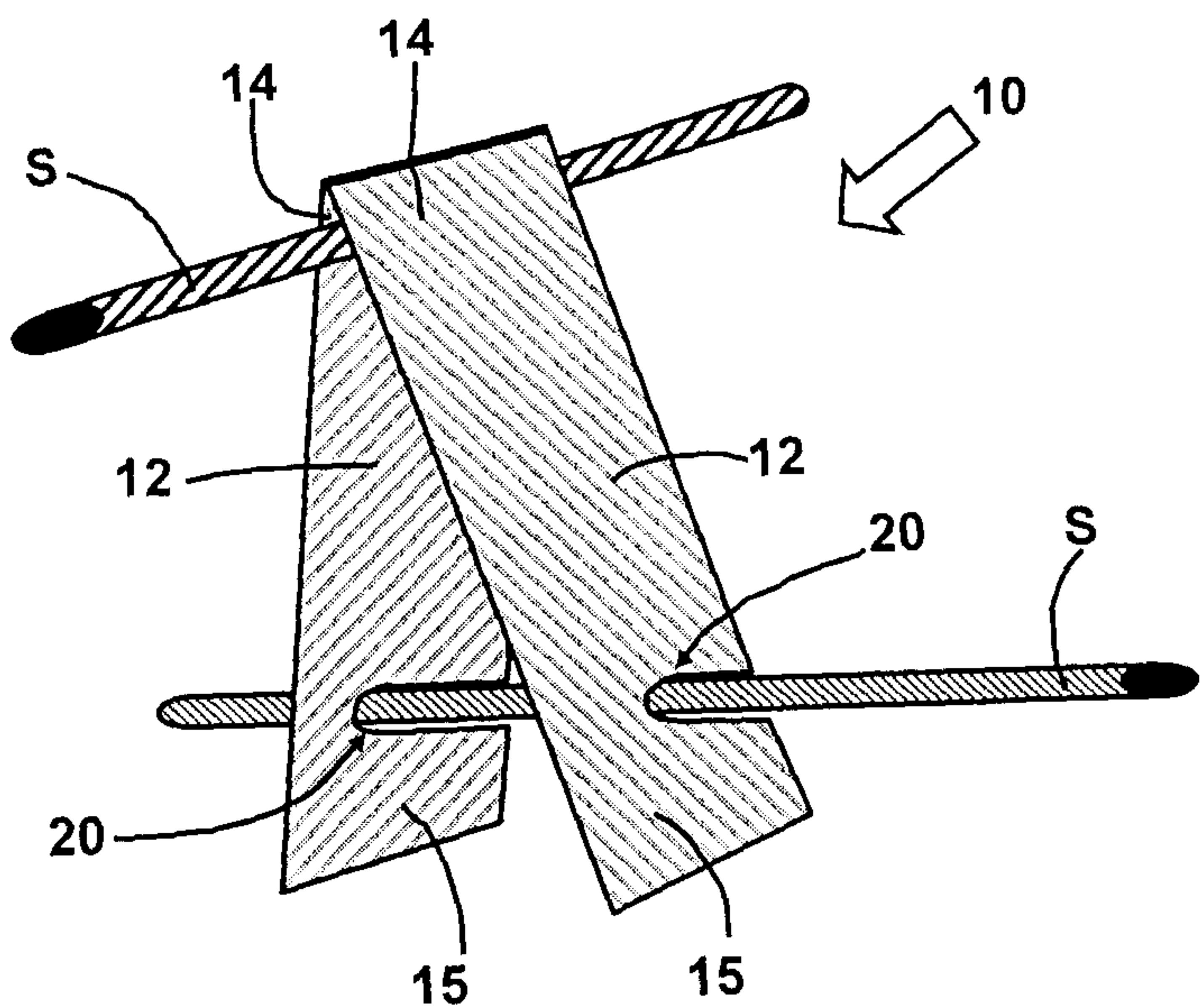

Fig. 18

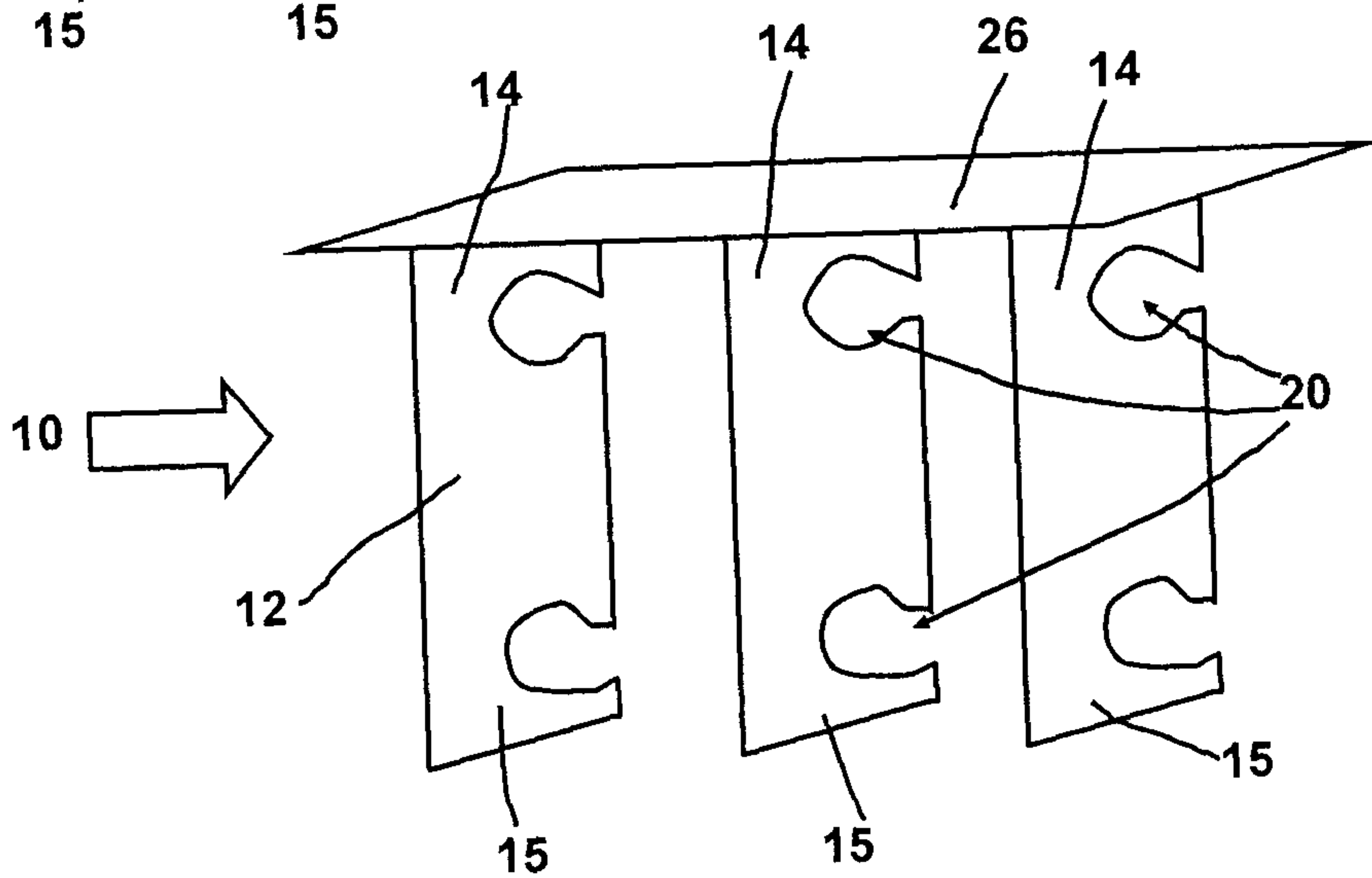

Fig. 19

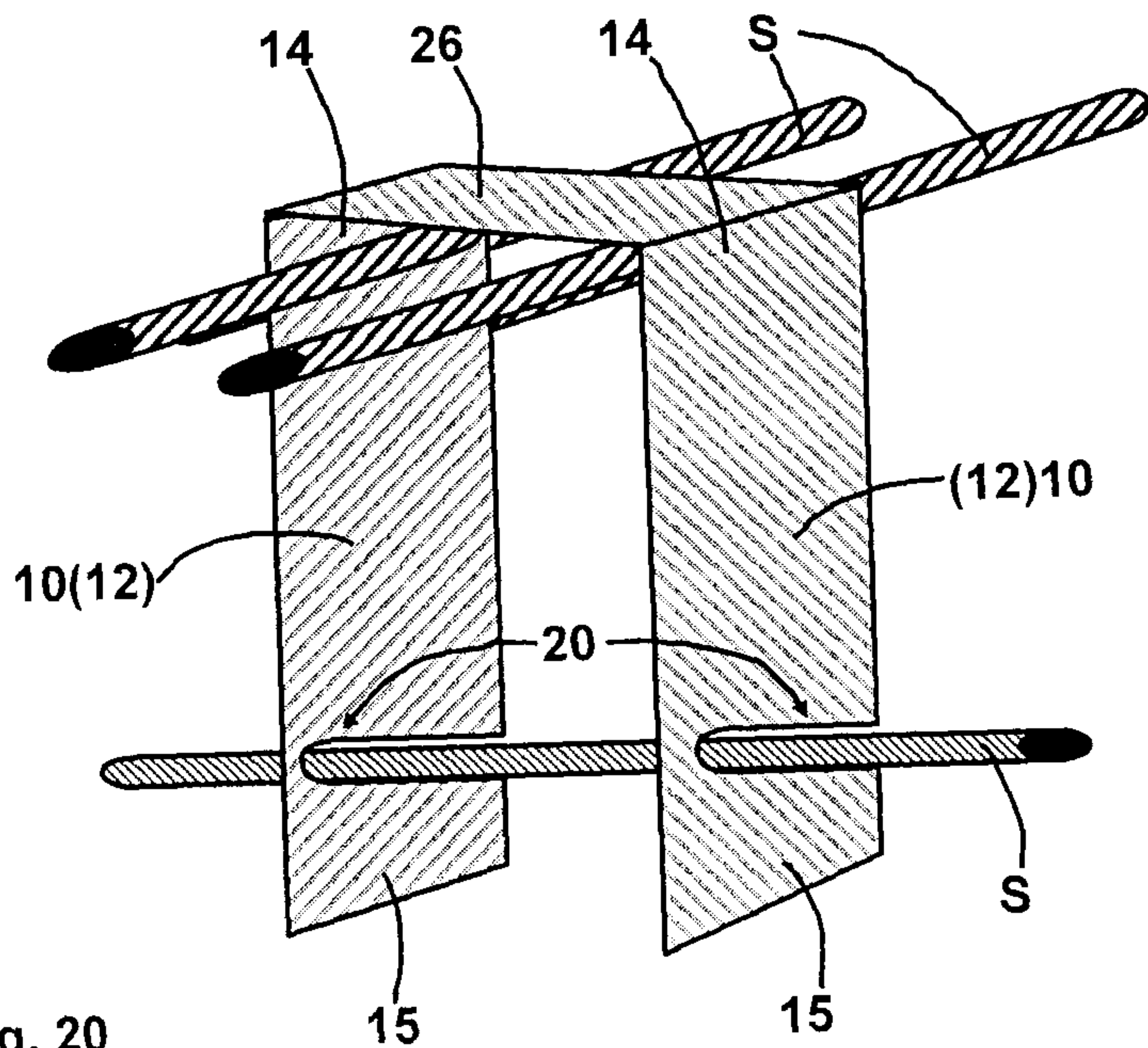

Fig. 20

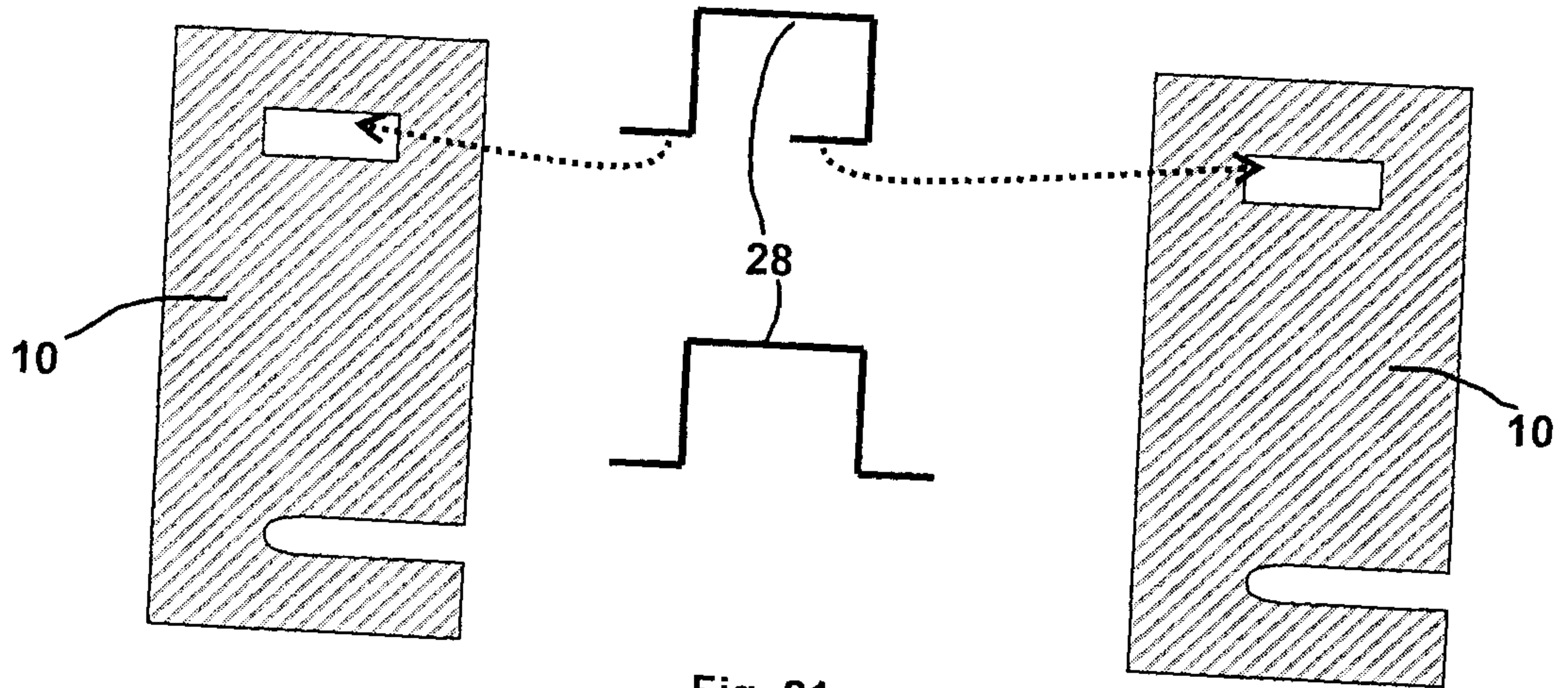

Fig. 21

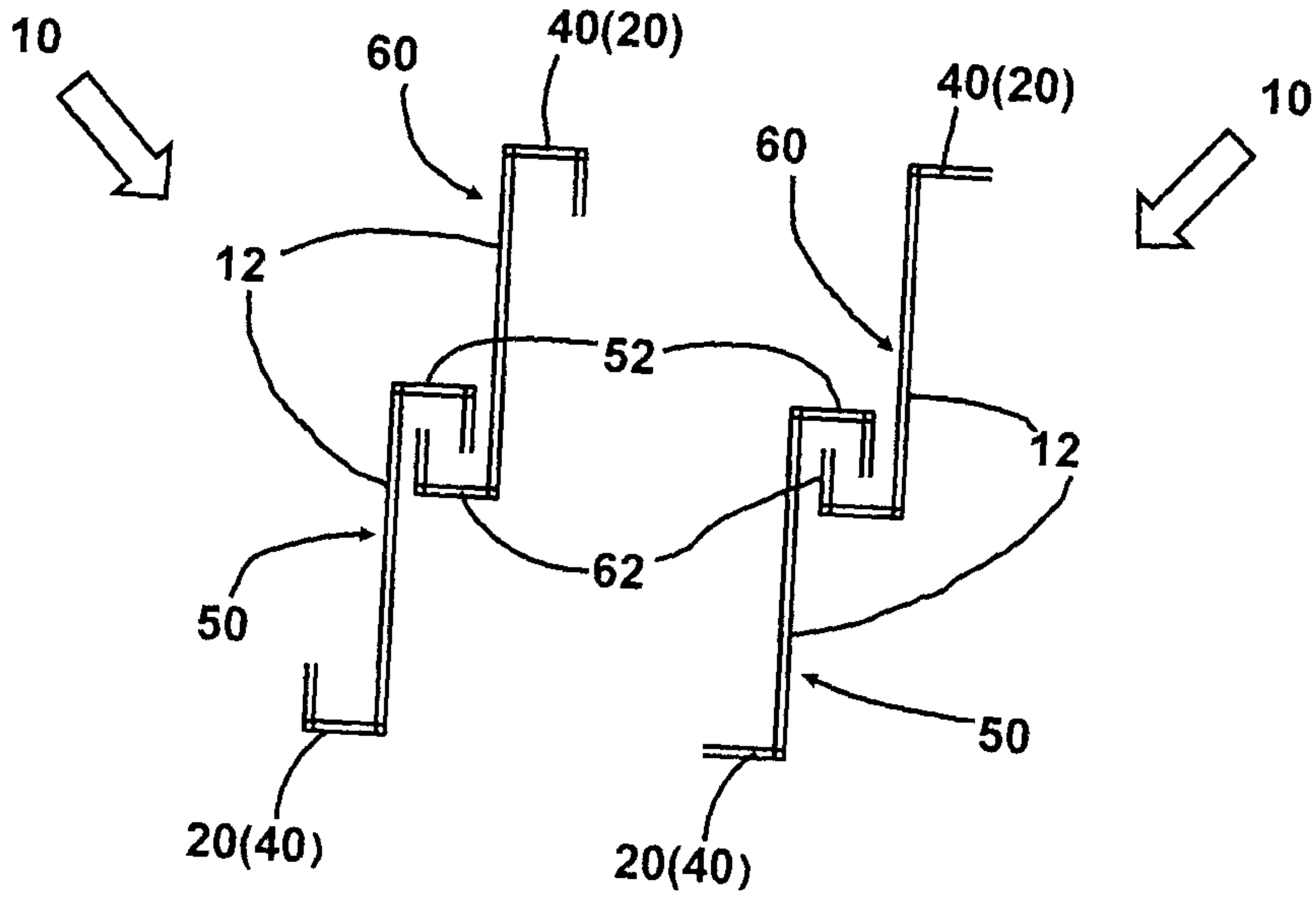

Fig. 22

Fig. 23

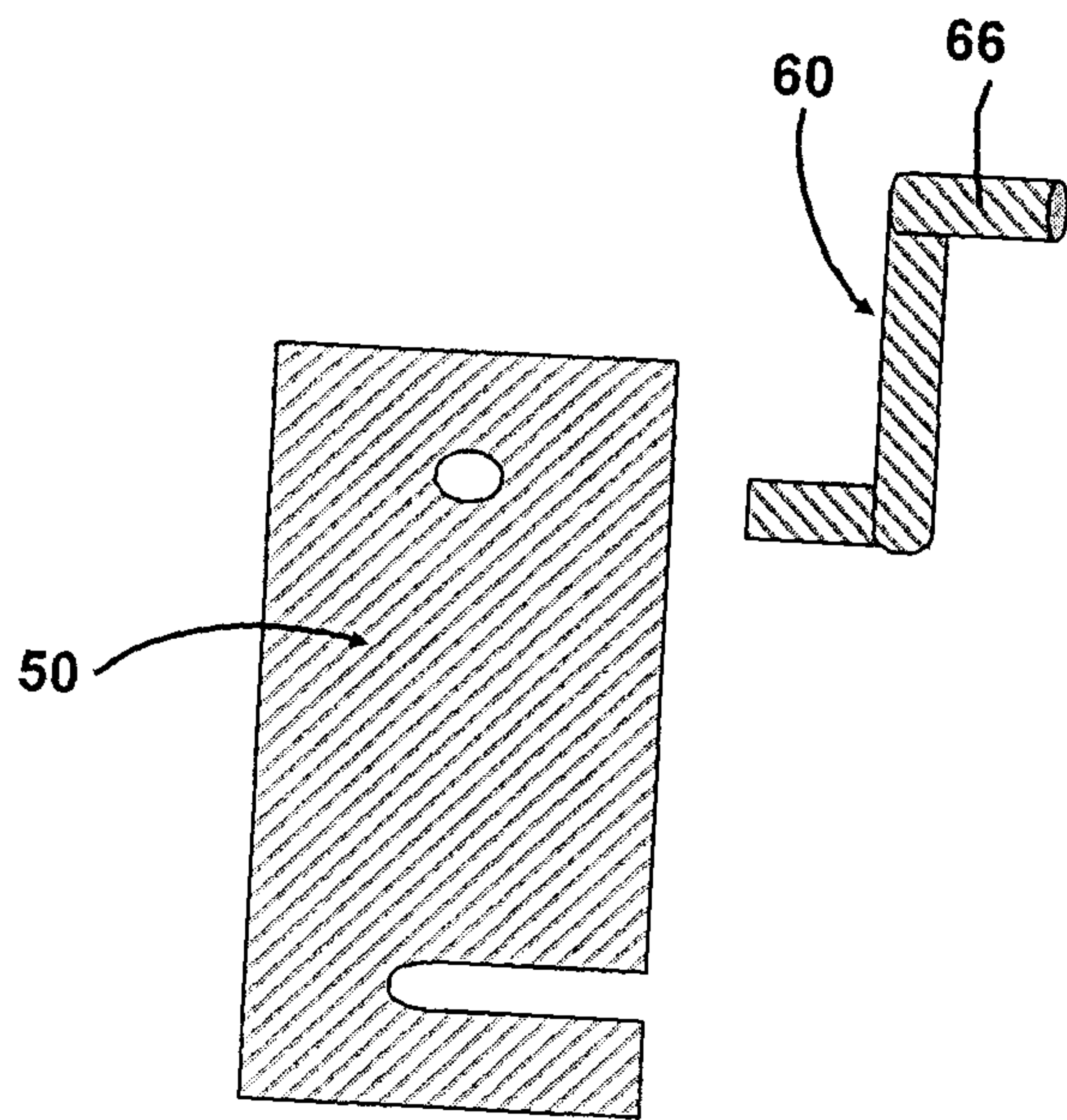

Fig. 24

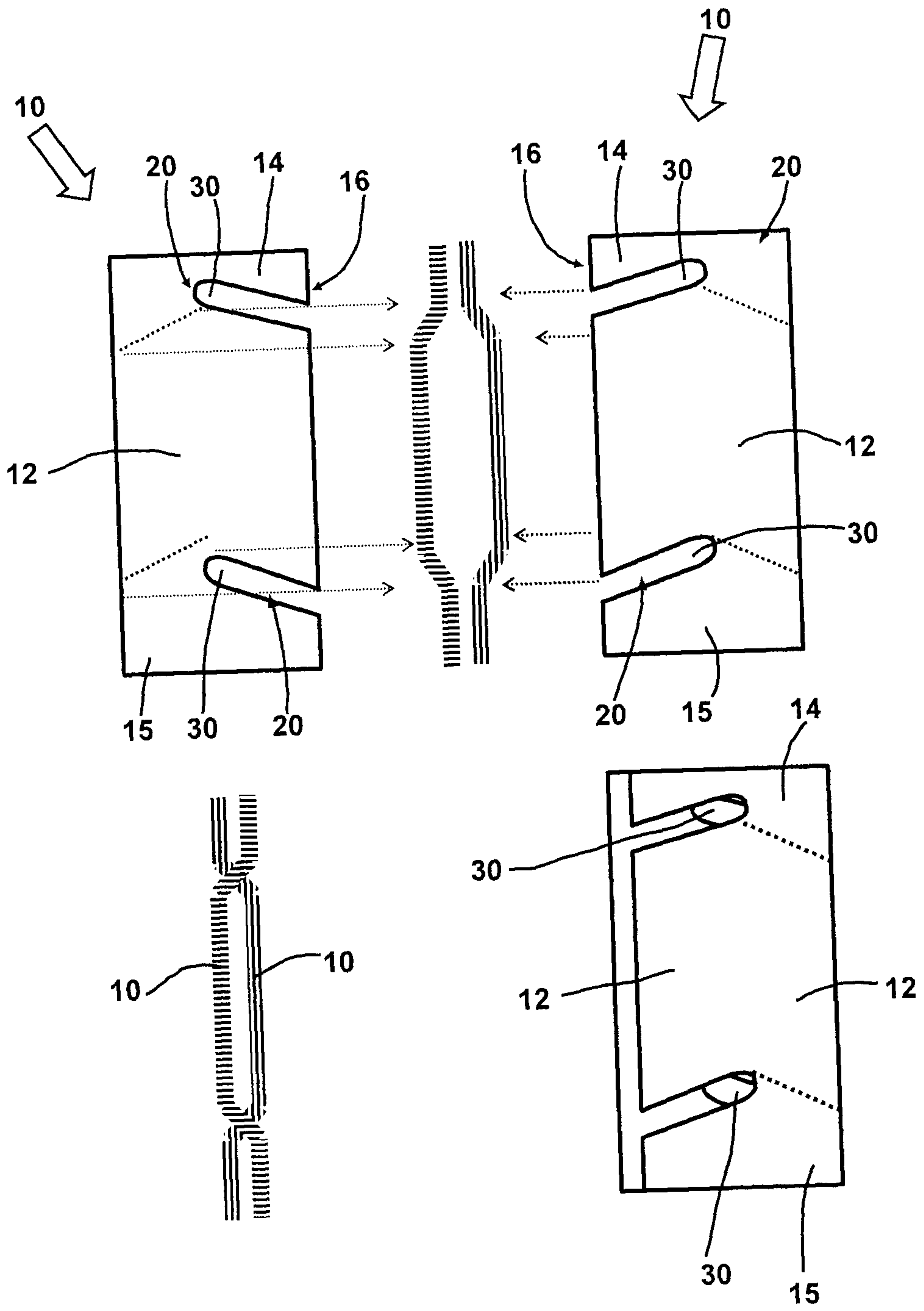

Fig. 25



