

Dec. 8, 1970

P. B. LIEBER

3,545,135

DOOR JAMB

Filed April 10, 1969

2 Sheets-Sheet 1

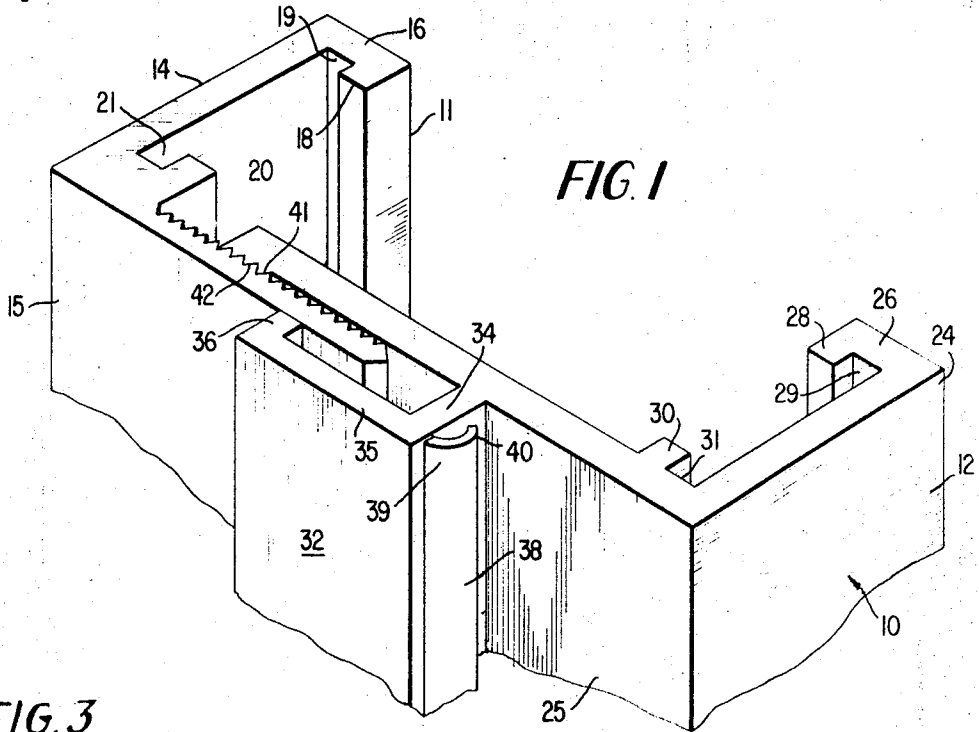

FIG. 1

FIG. 3

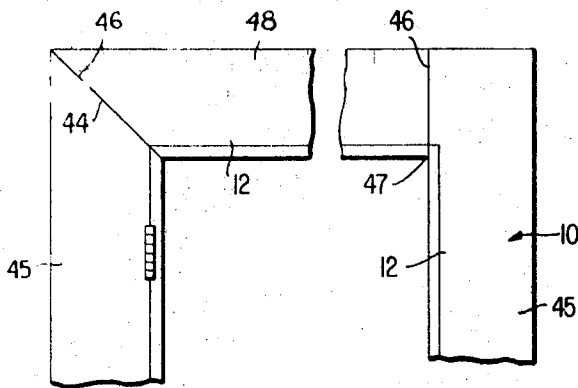

FIG. 2

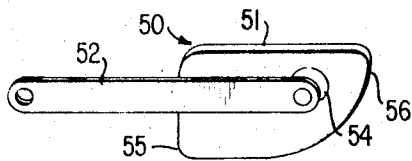
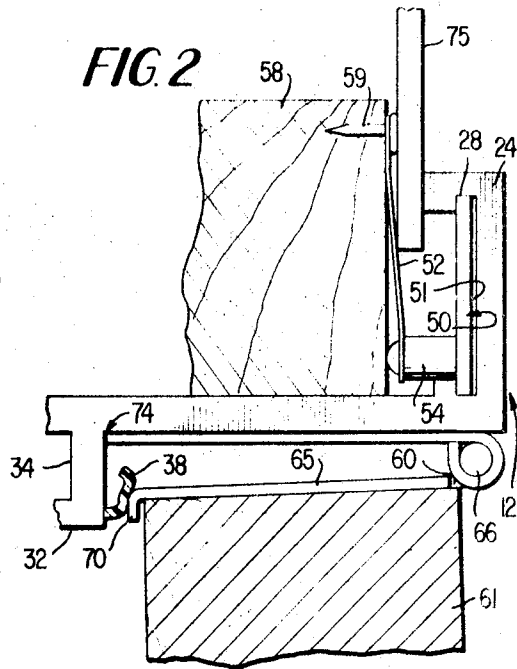

FIG. 4

INVENTOR  
PHILIP BEN LIEBER

BY *Newton, Hopkins & Ormby*  
ATTORNEYS

Dec. 8, 1970

P. B. LIEBER

3,545,135

DOOR JAMB

Filed April 10, 1969

2 Sheets-Sheet 2

FIG. 6

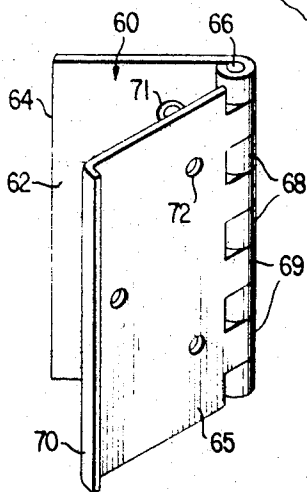
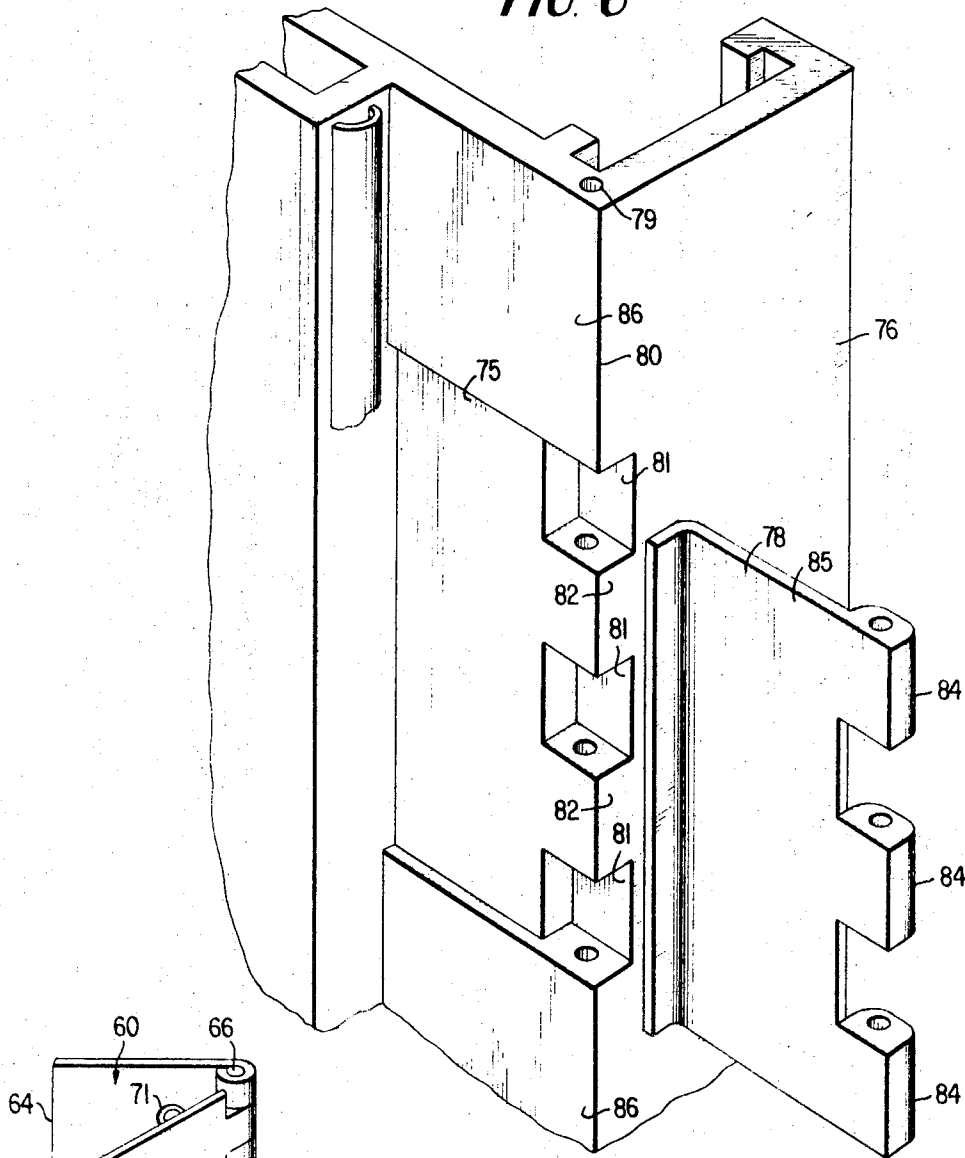

FIG. 5

INVENTOR  
PHILIP BEN LIEBER

BY *Newton, Hopkins & Ormsby*  
ATTORNEYS

1

3,545,135  
DOOR JAMB

Philip Ben Lieber, 1151 Prospect Ave., Apt. 2,  
Shreveport, La. 71105

Continuation-in-part of application Ser. No. 797,369, Jan. 29, 1969, which is a continuation of application Ser. No. 621,725, Mar. 1, 1967. This application Apr. 10, 1969, Ser. No. 815,079

Int. Cl. E06b 1/10

U.S. Cl. 49—505

7 Claims

2

While there has been some development in prefabricating door jambs, the various types of wood and various cuts made thereon are still required when utilizing the conventional wood door frames. Furthermore, prefabricated wooden door jambs have been found unsatisfactory for the most part, since they are difficult to connect to the supporting structure of a wall where they must usually be partially disassembled before connection.

Hinges applied to a door have always been an eye-sore as they project outwardly and clothing, etc., can become caught on them. With the hinge shaped to the identical contour of the door jamb and return trim, when the knuckles of the jamb portion and door portion of the hinge interlock, they are in the same plane and are practically invisible.

## SUMMARY OF THE INVENTION

Accordingly, an object of the present invention is to provide a door jamb that is economically and expediently constructed at a location of its manufacture, and expediently assembled at the location of its use.

Another object of this invention is to provide a door jamb that is assembled at its location of use without nails or other fastening means.

Another object of this invention is to provide a prefabricated door jamb that includes weather stripping.

Another object of this invention is to provide a prefabricated door jamb which includes weather stripping integrally formed therewith.

Another object of this invention is to provide the combination of a door jamb and a door hinge, wherein the door hinge is constructed to position a door at a predetermined distance from the door stop of the door jamb.

Another object of this invention is to provide the combination of a door jamb and a door hinge, wherein the door hinge is constructed so as to provide a gauge for positioning a door in the proper position on the hinge.

Another object of this invention is to provide the combination of a door jamb and a door hinge wherein the door hinge is constructed in such a manner that the pin cannot be removed while the door is closed for forcible entry as can hinges of the type presently being used.

Briefly, in accordance with one embodiment of this invention, the foregoing and other objects are attained by providing an extruded plastic door jamb which is fabricated in two sections, transported to the location of assembly, and connected to the wall structure by connecting the two sections to each other. The two sections have interengaging serrated surfaces that are forced into engagement with each other upon assembly so that no nails or other fastening means are required in their assembly. Furthermore, the noise deadening or weather stripping means is included adjacent the door stop to soften the noise usually created when the door is closed and to prevent air from traveling between the door and door jamb. A hinge is provided for cooperating with the door jamb that accurately places the door within the door jamb so that it properly engages the weather stripping means.

Many other advantages and objects of the present invention will become readily apparent as the following detailed description of the invention unfolds when taken in conjunction with the accompanying drawings.

## BRIEF DESCRIPTION OF THE DRAWING

FIG. 1 is a partial perspective view of a door jamb, showing the two sections of the door jamb assembled with each other;

FIG. 2 is a partial plan view, in cross-section, of an assembled door jamb, showing the door jamb, hinge and door;

FIG. 3 is a partial elevational view of an assembled

## ABSTRACT OF THE DISCLOSURE

An extruded plastic door jamb fabricated in two sections having interengaging serrated surfaces for holding the two sections in tight engagement with the wall section to which the door jamb is to be attached. Each of the two sections has an elongated longitudinal slot therein for receiving a cam lock mechanism having an attaching strap extending therefrom for anchoring the door jamb to the wall structure. An elongated strip of noise deadening or weather stripping is integrally formed on one of the two sections. A hinge is provided for cooperation with the door jamb and has a pair of hinge leaves, one of which is smaller in width than the other and has a perpendicular flange formed on the free end thereof for accurately placing the door within the door jamb so that it properly engages the weather stripping means. In the alternative, an elongated aperture extends adjacent one edge of one of the door jamb sections with spaced recesses cut into the edge portion to expose the aperture at various positions for receiving ring knuckles of a single hinge plate having a perpendicular flange on the free edge thereof.

In the second alternative, the door leaf of the hinge is shaped in such a manner that from the point where it leaves contact with the door, it conforms exactly to the shape of the door jamb and the return trim. When the jamb and the door leaf of the hinge are alternatively notched so that they will inter-leaf and a rod is inserted into an extruded hole in the jamb, it will interlock with the holes in the leaf. The jamb may be cut-away if so desired such that the jamb and leaf will provide a smooth surface.

## CROSS-REFERENCE TO RELATED APPLICATION

This application is a continuation-in part of application Ser. No. 797,369, filed Jan. 29, 1969, for "Door Jamb" now abandoned which was a continuation of Ser. No. 621,725, filed Mar. 1, 1967, for "Door Jamb," now abandoned by the same inventor.

## BACKGROUND OF THE INVENTION

This invention relates generally to door jambs, and more particularly to a prefabricated door jamb for a building wherein the door jamb can be manufactured at a remote point and transported to the location of its installation and connected to the frame structure of a wall with a minimum effort on behalf of the carpenter.

In the construction business, one of the problems of the carpenter is constructing or "hanging" of doors. Since a door must hang properly from the door jamb in order to easily swing open and shut, and engage a latching mechanism to remain shut, the hanging of a door requires the hand of an experienced carpenter. Also, door jamb construction is tedious since several sizes of wood are required to construct the various parts thereof; i.e., the trim, jamb and stop. The carpenter is required to stock the various sizes of wood required in the door jamb construction and to make the various cuts required on the various pieces of wood.

3

door jamb, illustrating alternate means for connecting the side pieces to the header;

FIG. 4 is a perspective view of a connecting strap utilized with the door jamb;

FIG. 5 is a perspective view of the hinge shown in FIG. 2; and

FIG. 6 is a partial perspective view of a door jamb, similar to FIG. 1, but showing another form of the invention.

#### DESCRIPTION OF THE ILLUSTRATIVE EMBODIMENT

Referring now to the drawings, wherein like reference characters designate identical or corresponding parts throughout the several views, and more particularly to FIG. 1, whereon there is shown a door jamb assembly 10 which includes a male section 11 and a female section 12. The male section 11 includes outer casing 14 and jamb section 15. The outer casing 14 includes an inwardly turned flange 16 and a tab 18 extending from the flange 16 in a direction generally parallel to the outer casing 14. The outer casing 14, flange 16, and tab 18 define a slot 19 extending the length of the male section 11. A tab 20 extends from the jamb section 15 parallel to the outer casing 14 and defines with the outer casing 14 and jamb section 15 a slot 21 of a size equal to the slot 19.

The female section 12 is constructed in a manner similar to the male section 11, in that it includes outer casing 24, jamb section 25, inwardly turned flange 26, tab 28, and tab 30. Tab 28, inwardly turned flange 26, and outer casing 24 define slot 29, while outer casing 24, jamb section 25 and tab 30 define slot 31.

Door stop assembly 32 is attached to the jamb section 25 of the female section 12 at a point intermediate its width, and comprises a door abutment leg 34 integrally attached to the jamb section 25 and extending in a direction perpendicular thereto, an outer leg 35 disposed perpendicular to the door abutment leg 34, and extending parallel to the jamb section 25, and holding tab 36 extending inwardly of the outer leg 35, toward the jamb section 25. A flexible U-shaped weather strip 38 is integrally formed to the door abutment leg 34, near its intersection with the outer leg 35 of the door stop assembly 32. The weather strip 38 includes a leg 39 extending outwardly from the door abutment leg 34, parallel to the jamb section 25, curved at the bottom 40 of its U, and extends toward the intersection of the door jamb section 25 and the door abutment leg 34 of the door stop assembly 32. The weather strip 38 is of substantially less thickness than the remaining portions of the door jamb assembly 10, and is therefore substantially more flexible than the remaining elements. By forming the weather strip 38 as an integral extruded part of the plastic female section 12, considerable time and expense are saved in the manufacture and assembly of the door jamb.

The door jamb section 25 is serrated on its outer surface, in an area remote from the outer casing 12, and includes a plurality of teeth 41 adjacent the edge of the jamb section. The jamb section 15 of the male section 11 includes a plurality of inwardly extending teeth 42 sized and shaped in a manner similar to the teeth 41 of the female section 12 and extending the entire length of the door jamb assembly.

As is best shown in FIG. 3, the upper end 44 of each vertically extending door jamb component 45 may terminate at a 45° angle (at the left of FIG. 3) or at a 90° angle (at the right of FIG. 3) and the ends 46 of the horizontally extending door jamb element or header 48 terminate at complementary angles, as in the usual construction, so that the vertical and horizontal elements of a door jamb assembly will properly fit together. Of course, the lower ends (not shown) of each vertical element 45 terminates in the usual 90° angle, so that the door jamb assembly is flush against the floor of the building. Because of the manner in which the connection of the elements

4

of the jamb is made at the right side of FIG. 3, the door stop assembly 32 of the header 48 must be cut away at 47 in a joint to accommodate the vertical component 45.

Connecting straps 50 are provided to hold the door jamb assembly 10 firmly in place against the door frame structure. The connecting straps 50 comprise a cam element 51 and a strap 52 connected thereto by means of projection 54. The cam element 51 is sized and shaped so that it can be inserted in the slots 19 and 21 of the male section 11 and 29 and 31 of the female section 12 by inserting the cam element through the tabs 18 and 20, or 28 and 30, respectively, and turning the cam element so that its flat end 55 is received in one of the slots 19, 21, 29 or 31, and its rounded end 56 is received in the slot opposite from the first slot. The projection 54 is sized so that the strap 52 is displaced a predetermined distance from the cam element 51. The strap 52 is of a length such that it extends beyond the inwardly turned flanges 16 or 26 of the male section 11 or female section 12, respectively. The strap 52 is connected to the frame structure or sub-jamb 58 of the door opening by means of nails 59 or other conventional connecting elements, such as screws, staples, etc. The strap 52 is manufactured from a relatively soft material such that the connecting elements of this type can easily penetrate it.

As is best shown in FIGS. 2 and 5, a hinge 60 is provided for connecting a door 61 to the door jamb assembly 10. The hinge 60 includes a leaf 62 adapted to be connected to the jamb section 25, with the vertical edge 64 of the leaf 62 being adapted to be positioned so that it abuts the door abutment leg 34 of the door stop assembly 32. Leaf 65 is connected to leaf 62 in the conventional manner by means of a pin 66 extending through aligned apertures formed by a series of pin encompassing rings 68 and 69. Leaf 65 is shorter in width than leaf 62 and terminates in a flange 70. The flange 70 extends in a direction normal to the surface of the leaf 65 and is disposed a distance from the pin 66 so that it is shorter than the width of leaf 62.

Leaves 62 and 65 each define a plurality of apertures 71 and 72, respectively, that are properly positioned to firmly attach the hinge to the door jamb, and to attach the door 61 to the hinge.

As is shown in FIG. 6, the door jamb assembly can be fabricated with recesses along the length of the female section to accommodate the door hinge leaf. Recesses 75 are positioned at intervals along the female section to accommodate a hinge leaf 78. The female section is fabricated with an aperture 79 extending lengthwise there-through adjacent its edge 80. Recesses 75 each include counter recesses 81 adjacent edge 80 that expose aperture 79 at intervals within each recess 75, thereby forming hinge knuckles 82. Hinge leaf 78 is constructed with hinge knuckles 84 along one edge thereof that are complementary in shape to the counter recesses 81 of the female section 76. The leaf portions 85 of the hinge leaf 78 is sized and shaped to be received in recess 75 of the female section 76. Thus, hinge leaf 78 can be positioned in recess 75 with its hinge knuckles 84 being received in counter recesses 81 so that the hinge leaf tends to form a smooth surface with the jamb section 86, to form a surface coextensive with the jamb section 86. When the hinge leaf 78 is positioned in recess 75 in this manner, a rod or similar elongate member (not shown) can be slipped through aperture 79, from the top of the female section 76, to form a hinge pin with the hinge leaf 78, respectively, to form a conventional function of a hinge pin. Hinge leaf 78 is similar in structure to hinge leaf 65 illustrated in FIG. 5 of the drawing, in that it includes a flange extending from one edge thereof normal to the surface of the hinge leaf. Again it is to be mentioned that the perpendicular flange serves the purposes of providing an accurate gauge for positioning a door onto the hinge leaf and for aligning the door properly with respect to the weather stripping which is formed integrally with the female section of the door jamb.

5

While FIG. 6 shows the female section 76 being fabricated with recesses 75 at intervals along its length, it should be understood that female section 76 may be fabricated without recesses 75 but with only aperture 79 extending throughout the portion of its length, adjacent edge 80, and hinge leaves similar to hinge leaf 78 can be connected thereto by merely cutting away recesses similar to counter recesses 81 to accommodate hinge knuckles similar to hinge knuckles 84.

The door jamb assembly 10 is fabricated from a vinyl or plastic from an extrusion procedure. The male section and the female section are each fabricated by extruding these components in separate operations. While the male section elements are substantially of uniform thickness, it will be noted that the female section elements vary in thickness in that the weather strip 38 integrally formed thereon is of smaller thickness than the remaining elements of the section. However, it has been found that the weather strip 38 together with the remaining elements of the female section 12 can be fabricated from a single extrusion operation whereby the thicker elements are fabricated with a desired rigidity and the weather strip 38 is fabricated with the desired flexibility. Here again, it is to be noted that the simultaneous extrusion of the female element and the weather stripping provides a great saving in time and expense in both the manufacture and the assembly of the door jamb.

The male section strip 11 and female section strips 12 are cut at their ends to form the vertically extending elements 45 of a door jamb assembly. Of course, the vertically extending elements must be cut at 90° angles to form the bottom ends and may be cut at 45° angles or 90° angles (FIG. 3) to form the upper ends thereof, while horizontally extending elements 48 must be cut at angles complementary to the vertically extending elements so that they will mate with the upper ends of the vertically extending elements.

After the fabrication of the door jamb assembly as described above, the components are transported to their location of assembly and use, whereupon the carpenter (or unskilled laborer) assembles the female sections 12 with the male sections 11 about the frame structure or door openings. The laborer merely places the female section 12 on one side of the door frame structure and wedges the male section 11 inwardly thereof. The jamb section 15 of the male section 11 is wedged between the holding tab 36 of the door stop assembly 32 and the jamb section 25 of the female section 12. The teeth 42 of the male section 11 engage the teeth 41 of the female section 12 so as to fasten these two sections together.

After the male and female sections of the door jamb assembly have been assembled in a rather loose fashion, the connecting straps 50 are inserted in the slots 19 and 21, and 29 and 31 of the male and female sections, by inserting cam elements 51 through the tabs 18 and 20, and 28 and 30, and twisting the cam elements 51 so that their flat sides 55 are received in slots 19 or 29 and their rounded ends 56 are received in slots 21 or 31. It should be noted that cam elements 51 may be inserted within the slots prior to joining the male and female sections. The male and female sections 11 and 12 can be wedged together more firmly after the insertion of the connecting straps 52, and the straps 52 of the connecting straps 50 are then fastened to the wooden structure 58 of the door frame assembly by nailing, stapling, etc., as shown at 59. The projection 54 of the connecting strap 50 is of a length sufficient to retain the tabs 18 and 28 at a predetermined distance from the frame structure 58, so that wall board siding 75 can later be slid between the frame structure 58 of the doorway and the outer casing 14 and 24. After the wall board 75 is properly positioned, the laborer can then make his last adjustment to the door jamb assembly 10 by firmly wedging the male and female sections 11 and 12 together.

After the door jamb assembly 10 has been assembled 75

6

in this manner, hinges 60 are then connected to the female section 12. The hinges 60 are placed with their leaves 62 against the jamb section 24, the edge 64 of the leaves 62 abutting the door abutment leg 34 of the door stop assembly 32. Since the leaf 65 of each hinge 60 is shorter in width than leaves 62, leaves 65 will be free to pivot about pivot pin 66 without engaging the door abutment leg 34 of the door stop assembly 32. Doors 61 are then connected to leaf 65 by placing each door on the hinges 60 so that they abut flanges 70. Thus, the unskilled laborer can connect the doors 61 to the hinges 60 with a precise fit and with a minimum of effort utilizing flanges 70 as a guide means.

As is best shown in FIG. 2, when the door 61 is shut, the weather strip 38 will flex to accommodate the door and hinge 60. Of course, this creates a seal between the door, hinge and door jamb to prevent light or air from passing between these elements. Of course, the door 61 also engages the weather strip 38 on the opposite side and top of the door jamb assembly 10 in a similar manner. Furthermore, placement of the weather strip 38 in this manner insures the closing of the door 61 and will not create undesirable noise. Thus, the unusual force exerted by the door on the door abutment leg is absorbed by the weather strip 38 to mute the noise.

Referring to FIG. 6, the door jamb assembly is assembled in the same manner as is shown in FIGS. 1-4, except that female section 76 may be used in lieu of female section 12. When female section 76 is used in the construction of a door jamb, hinge leaf 78 is connected to female section 76 by insertion of an elongate rod or similarly configured member through aperture 79, through knuckles 84 of hinge leaf 78, and through hinge knuckles 82 of female section 76.

As previously stated, the female section may be fabricated without recesses 75 but with aperture 79 (FIG. 1). With this construction, a single hinge leaf may be attached to the female section by cutting away portions of the edge of the female section to form recesses therein which will accommodate the hinge knuckles of a hinge leaf. This particular construction is especially convenient since the hinge leaf may be connected to the door jamb assembly at any elevation, and a hinge similar to that of FIG. 5 may be utilized or a single leaf hinge construction may be connected to the female section.

Also, the use of hinge 60 is not limited to being used with the door jamb assembly disclosed herein. Furthermore, the elements of the door jamb assembly 10 can be held together without the aid of the connecting straps 50 since the angles of the upper portion of the elements tends to hold these elements in proper relationship to each other and the screws that connect the hinges 60 to the female section 12 will penetrate the wood of the frame structure 48 of the door frame opening. Also, if any threshold weather strip is to be used, this element will tend to hold the lower portions of the vertically extending elements apart from each other.

It will be obvious to those skilled in the art that many variations may be made in the embodiments chosen for the purpose of illustrating the present invention without departing from the scope thereof as defined in the appended claims.

What is claimed as invention is:

1. A plastic door jamb assembly comprising:

a male section,

a female section,

said male section including an outer casing for positioning flush with one side of the outer surface of a wall and a jamb section for positioning in the door opening perpendicular to the outer surface of a wall, said outer casing of said male section including a pair of tabs extending the entire length thereof and each defining with said outer casing a slot,

said jamb section of said male section including an inner surface defining a series of serrations thereon,

7

said female section including an outer casing for positioning flush with the opposite side of the outer surface of a wall and a jamb section for positioning in the door opening perpendicular to the outer surface of a wall, said outer casing of said female section including a pair of tabs extending the entire length thereof and each defining with its outer casing a slot, said jamb section of said female section including an outer surface defining a series of serrations thereon, said jamb section of said female section including a door stop assembly integrally attached thereto and comprising a door abutment leg attached to and extending outwardly from said jamb section, an outer leg extending generally parallel to said jamb section and a holding tab extending from said outer leg toward said jamb section and being constructed and arranged to urge the serrations of the jamb section of said male section into engagement with the serrations of the jamb section of said female section, and said door abutment leg of said door stop assembly defining a door abutment face and a flexible strip integrally formed with and extending the length thereof.

2. A door jamb assembly according to claim 1 further comprising connecting means positionable in said slots for connecting said door jamb assembly to a wall structure.

3. A door jamb assembly according to claim 2 wherein said connecting means comprises a cam member positionable in said slots, and

a flexible strap member secured to said cam member and extending therefrom.

4. A door jamb assembly according to claim 3 wherein said flexible strap is of sufficient length so as to protrude beyond said outer casing when said cam is positioned within said slot.

5. A plastic door jamb assembly comprising a vertical

8

wall engaging member extending the height of the door opening and having a longitudinally extending aperture defined therein adjacent one edge thereof, said edge of said wall engaging member having a plurality of longitudinally spaced recesses, each of said recesses including a plurality of longitudinally spaced counter recesses defined therein for exposing said aperture, a plurality of hinge leaves, each having a plate portion, and a plurality of spaced pin encompassing rings along one edge thereof, said plate portions of said hinge leaves received in said recesses, said spaced pin rings received in said counter recesses, and an elongated pin within said aperture and engaging said rings for pivotally mounting said hinge leaves on said wall engaging members.

6. A door jamb assembly according to claim 5 further comprising an elongated strip of flexible material integral with and extending from said wall engaging member.

7. A door jamb assembly according to claim 5 wherein said hinged leaf has the edge thereof remote from said rings defining an angled flange extending away from said wall engaging member.

#### References Cited

##### UNITED STATES PATENTS

2,575,793	11/1951	Bush .....	49—496XR
2,600,072	6/1952	Peremi .....	52—217
2,752,014	6/1956	Watson .....	49—397
3,072,229	1/1963	Pasche et al. ....	49—495XR
3,102,307	9/1963	Johnson et al. ....	49—399XR
3,141,205	7/1964	Russell .....	49—504XR
3,324,599	6/1967	Brost .....	49—505
3,360,888	1/1968	Protzman .....	49—496

KENNETH DOWNEY, Primary Examiner

U.S. Cl. X.R.

16—128; 52—213