

(19) World Intellectual Property Organization
International Bureau



(43) International Publication Date
10 May 2001 (10.05.2001)

PCT

(10) International Publication Number
WO 01/32799 A1

(51) International Patent Classification⁷: **C09K 3/14**,
C09G 1/02, 1/04, C03C 17/00, 8/20, 17/34, C09K 11/08,
11/78, 11/70, H01J 29/18, B32B 5/16, B24D 3/00, B23B
27/00, C23C 14/06, C01B 31/00, 33/14, 33/20, C01F 7/02,
17/00, C01G 9/02, 19/02, 23/047, 25/02, 45/02, 49/02

840 Hobart Street, Menlo Park, CA 94025 (US). **KU-
MAR, Sujeet**; 39800 Fremont Boulevard #206, Fremont,
CA 94538 (US). **BI, Xiangxin**; 677 Graylyn Drive, San
Ramon, CA 94583 (US).

(21) International Application Number: PCT/US00/30288

(74) Agents: **DARDI, Peter, S.** et al.; Westman, Champlin &
Kelly, P.A., Suite 1600 - International Centre, 900 Second
Avenue South, Minneapolis, MN 55402-3319 (US).

(22) International Filing Date:
2 November 2000 (02.11.2000)

(81) Designated States (*national*): CN, IN, JP, KR.

(25) Filing Language: English

(84) Designated States (*regional*): European patent (AT, BE,
CH, CY, DE, DK, ES, FI, FR, GB, GR, IE, IT, LU, MC,
NL, PT, SE, TR).

(26) Publication Language: English

(30) Priority Data:
09/433,202 4 November 1999 (04.11.1999) US

Published:
— *With international search report.*

(71) Applicant: **NANOGRAM CORPORATION** [US/US];
46774 Lakeview Boulevard, Fremont, CA 94538 (US).

*For two-letter codes and other abbreviations, refer to the "Guid-
ance Notes on Codes and Abbreviations" appearing at the begin-
ning of each regular issue of the PCT Gazette.*

(72) Inventors: **REITZ, Hariklia, Dris**; 2147 Newhall Street
#212, Santa Clara, CA 95050 (US). **KAMBE, Nobuyuki**;

(54) Title: PARTICLE DISPERSIONS

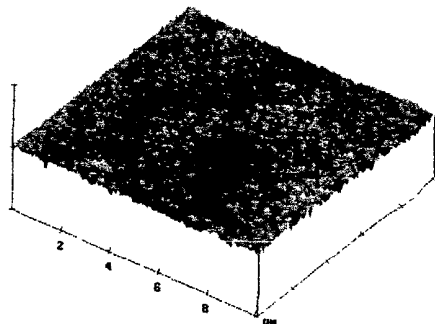

(57) Abstract: Improved particle dispersions are formed using nanopar-
ticles with average primary particle diameters less than about 100 nm.
The collection of nanoparticles in the dispersion have very narrow par-
ticles size distributions that do not have tails at larger particle sizes. In
particular, the collection of nanoparticles effectively do not have primary
particles with a diameter greater than three times the average particle
diameter. The improved dispersions can be used in the formation of pol-
ishing compositions for chemical-mechanical polishing and in the pro-
duction of thin coatings.

RMS: 0.46 nm
 R_{max} : 5.76 nm

WO 01/32799 A1

-1-

PARTICLE DISPERSIONS

BACKGROUND OF THE INVENTION

The invention relates to dispersions of nanoscale particles. The invention further relates to surface polishing with dispersions of nanoscale particles and the formation of coatings.

Technological advances have increased the demand for improved material processing with strict tolerances on processing parameters. In particular, the development of new products, such as products with miniaturized components, have created a demand for many types of new materials for use in advanced processing techniques. To meet some of these demands, a variety of chemical powders can be used in many different processing contexts. Specifically, there is considerable interest in the application of ultrafine or nanoscale powders that are particularly advantageous for a variety of applications involving small structures or high surface area materials. This demand for ultrafine chemical powders has resulted in the development of sophisticated techniques, such as laser pyrolysis, for the production of these powders.

Ceramic powders, especially powders of metal or silicon compounds, are of interest for a range of different applications. For example, various ceramic powders can be used to form abrasives for the polishing of very smooth surfaces. Also, chemical powders can be used in the production of electronic devices, such as resistors, capacitors, inductors and transistors, and optical devices, such as waveguides, optical switches and non-linear optical devices. Other specific electronic devices include electronic displays, which often use phosphor material that emit visible light in

-2-

response to interaction with electrons. Similarly, ceramic powders can be useful in the production of coatings within microelectronic devices. The use of chemical powders for various applications requires
5 specific processing approaches in order to place the powders in a suitable form for the application.

Smooth surfaces are required in a variety of applications in electronics, tool production and many other industries. The substrates requiring polishing
10 can involve materials such as semiconductors, ceramics, glass and metal. As miniaturization continues even further, even more precise polishing may be required. Current submicron technology requires polishing accuracy on a nanometer scale over significant substrate areas.
15 Precise polishing technology can employ chemical-mechanical polishing involving a polishing composition that acts by way of a chemical interaction of the substrate with the polishing agents as well as an abrasive effective for mechanical smoothing of the
20 surface.

SUMMARY OF THE INVENTION

In a first aspect, the invention pertains to a particle dispersion comprising a solvent and a collection of particles at a concentration of less than
25 about 50 weight percent in the dispersion, the collection of particles having an average primary particle diameter less than about 100 nm and effectively no particles having a primary particle diameter greater than about three times the average primary particle
30 diameter. The improved particle dispersions can be used in surface polishing.

In another aspect, the invention pertains to a method for forming a particle dispersion, the method comprising mixing a collection of particles with a

-3-

solvent, the collection of particles having an average primary particle diameter from about 5 nm to about 50 nm and effectively no particles having a primary particle diameter greater than about three times the average
5 primary particle diameter.

In a further aspect, the invention pertains to a method for polishing a surface comprising a metal or metal compound, the method comprising abrading the surface with a particle dispersion having a
10 concentration of particles less than about 5 weight percent and the particle dispersion comprising a collection of particles having an average primary particle diameter less than about 100 nm.

In addition, the invention pertains to a
15 method for polishing a surface comprising metal or a metal compound, the method comprising abrading the surface with a particle dispersion, the particle dispersion comprising a collection of particles having an average primary particle diameter less than about 100
20 nm, the abrasion removing greater than about a factor of two more material from the surface per unit time than corresponding polishing with an equivalent concentration of particles having an equivalent composition and an average particle diameter of greater than about 1
25 micron.

Furthermore, the invention pertains to a method for polishing a surface comprising a metal or a metal compound, the method comprising abrading the surface with a particle dispersion to produce a surface
30 with a root mean square roughness of less than about 0.75 nm.

In another aspect, the invention pertains to a device having a surface with a coating comprising a collection of particles having an average primary

-4-

particle diameter less than about 100 nm and effectively no particles having a primary particle diameter greater than about three times the average primary particle diameter.

5

BRIEF DESCRIPTION OF THE DRAWINGS

Fig. 1 is a schematic, sectional view of an embodiment of a laser pyrolysis apparatus taken through the middle of the laser radiation path. The lower inserts are bottom views of the injection nozzle with one or two reactant inlets, and the upper insert is a bottom view of the collection nozzle.

10

Fig. 2 is a schematic view of a reactant delivery apparatus for the delivery of vapor reactants to the laser pyrolysis apparatus of Fig. 1.

15

Fig. 3 is a schematic sectional view of a solid precursor delivery system taken through the center of the system.

Fig. 4 is schematic, side view of a reactant delivery apparatus for the delivery of an aerosol reactant to the laser pyrolysis apparatus of Fig. 1.

20

Fig. 5 is schematic, side view of an alternative embodiment of a reactant delivery apparatus for the delivery of an aerosol reactant to the laser pyrolysis apparatus of Fig. 1.

25

Fig. 6 is a schematic, perspective view of a reaction chamber of an alternative embodiment of the laser pyrolysis apparatus, where the materials of the chamber are depicted as transparent to reveal the interior of the apparatus.

30

Fig. 7 is a perspective view of an embodiment of a laser pyrolysis apparatus with an elongated reaction chamber.

-5-

Fig. 8 is a sectional view of the laser pyrolysis apparatus of Fig. 7, where the section is taken along line 8-8 of Fig. 7.

5 Fig. 9 is a schematic, sectional view of an apparatus for heat treating nanoparticles, in which the section is taken through the center of the apparatus.

Fig. 10 is an x-ray diffractogram of silicon nitride nanoparticles produced by laser pyrolysis.

10 Fig. 11 is a transmission electron micrograph of silicon nitride nanoparticles equivalent to those used to produce the x-ray diffractogram of Fig. 10.

Fig. 12 is a particle size distribution obtained from the micrograph in Fig. 11.

15 Fig. 13 is an x-ray diffractogram of silicon carbide nanoparticles produced by laser pyrolysis.

Fig. 14 is a transmission electron micrograph of silicon carbide nanoparticles equivalent of those used to produce the x-ray diffractogram of Fig. 13.

20 Fig. 15 is a particle size distribution obtained from the micrograph of Fig. 14.

Fig. 16 is a plot of atomic force microscope measurements of surface roughness of a tungsten wafer.

25 Fig. 17 is a plot of atomic force microscope measurements made of a tungsten wafer following polishing with an aluminum oxide nanoparticle slurry.

DETAILED DESCRIPTION OF THE ILLUSTRATIVE EMBODIMENTS

30 With the development of approaches for producing highly uniform particles having average diameters of primary particles less than about 100 nm, these particles can be dispersed in liquids to form improved dispersions. In particular, the highly uniform nanoparticle collections have an extremely narrow particle size distribution. The dispersions of the

-6-

uniform nanoparticles are useful in a variety of processing contexts.

Particles with a high uniformity in size are particularly well suited for use in chemical-mechanical polishing for planarization. Due to the high uniformity of the particle size, chemical-mechanical polishing with the particles results in surfaces with reduced roughness. Nanoscale particles have unique characteristics that may alter the properties of formulations comprising the nanoscale particles. Thus, the characteristics of the nanoscale particles may influence the processing approaches in a variety of applications. The dispersions are also useful in the production of coatings, for example, in the production of microelectronic components.

Laser pyrolysis is an excellent approach for efficiently producing a wide range of nanoscale particles with a narrow distribution of average particle diameters. In particular, laser pyrolysis can be used to produce a variety of nanoscale particles, such as carbon particles, metal particles, metal and silicon (metal/silicon) oxides, metal/silicon carbides, metal/silicon nitrides and metal/silicon sulfides. A basic feature of successful application of laser pyrolysis for the production of desirable nanoparticles is the generation of a reactant stream containing a metal/silicon precursor compound, a radiation absorber and, generally, a secondary reactant. The secondary reactant can be a source of atoms, such as oxygen, required for the desired product or an oxidizing or reducing agent to produce a desired product formation. A secondary reactant is not needed if the precursor decomposes to the desired product under intense light radiation. The reactant stream is pyrolyzed by an

-7-

intense light beam, generally a laser beam. As the reactant stream leaves the laser beam, the particles are rapidly quenched.

To perform laser pyrolysis, reactants can be
5 supplied in vapor form. Alternatively, one or more
reactants can be supplied as an aerosol. The use of an
aerosol provides for the use of a wider range of
metal/silicon precursors for laser pyrolysis than are
suitable for vapor delivery only. Thus, less expensive
10 precursors can be used with aerosol delivery. Suitable
control of the reaction conditions with the aerosol
results in nanoscale particles with a narrow particle
size distribution. Nanoparticles produced by laser
pyrolysis can be subjected to additional processing to
15 alter the nature of the particles, such as the
composition and/or the crystallinity. Under suitably
mild conditions, heat processing is effective to modify
the characteristics of the particles without destroying
the nanoscale size or the narrow particle size
20 distribution of the initial particles.

Preferred collections of nanoparticles for
forming dispersions have an average diameter less than
a 100 nm and a very narrow distribution of primary
particle diameters. In particular, the distribution of
25 primary particle diameters preferably does not have a
tail. In other words, there are effectively no
particles with a diameter four times greater than the
average diameter such that the particle size
distribution rapidly drops to zero. Not only does the
30 particle size distribution not have a tail, the peak of
the distribution is also very narrow, as described
further below.

Laser pyrolysis involves the reaction of a
reactant stream within a reaction chamber where any

-8-

solvent present is rapidly vaporized as the reactants flow into the reaction zone. A dry powder of nanoparticles is produced. The nanoparticles can be subjected to heat processing in a gas atmosphere prior to use. For many applications, the powders must be dispersed in a liquid for use or for further processing. For the purposes of discussion herein, particle dispersions have concentrations of nanoparticles no more than about 50 weight percent.

The nanoparticles have unique properties due to their small particle size. In particular, the particles have extremely large surface areas. The large surface areas can lead to significant non-bonding interactions between the particles. Forming preferred dispersions involves disrupting a significant number of these non-bonding interactions. In preferred dispersions, the average diameter of the secondary, i.e., dispersed, particles sizes preferably is less than about 1000 nm.

The dispersions described herein can be used in a variety of applications. An application of significant interest is chemical-mechanical polishing. The nanoparticles can be used as abrasive components and/or chemical components of a chemical-mechanical polishing composition. The dispersions of the uniform nanoparticles can be used as a chemical-mechanical polishing composition. Additional components added to the dispersions can impart functional characteristics of the resulting polishing composition, as described further below. The polishing compositions/dispersions can be used to produce surfaces with reduced surface roughness due to the uniformity of the particles in the polishing composition. The polishing

-9-

compositions/dispersions also can yield high polishing rates.

A. Particle Production Using Laser Pyrolysis

Laser pyrolysis has been discovered to be a
5 valuable tool for the production of nanoscale particles,
including, in particular, carbon particles, metal
particles, metal/silicon oxide particles, metal/silicon
carbide particles, metal/silicon nitride particles and
metal/silicon sulfide particles. In addition, the
10 particles produced by laser pyrolysis are a convenient
material for further heat processing under mild
conditions to expand the pathways for the production of
desirable metal/silicon oxide particles. Thus, using
laser pyrolysis alone or in combination with additional
15 processes, a wide variety of nanoscale particles can be
produced.

The reaction conditions determine the
qualities of the particles produced by laser pyrolysis.
The reaction conditions for laser pyrolysis can be
20 controlled relatively precisely in order to produce
particles with desired properties. The appropriate
reaction conditions to produce a certain type of
particles generally depend on the design of the
particular apparatus.

25 Specific conditions used to produce silicon
carbide nanoparticles and silicon nitride nanoparticles
in two particular apparatuses are described below in the
Examples. Also, references describing details of the
production of a variety of different nanoparticles by
30 laser pyrolysis are presented below. Furthermore, some
general observations on the relationship between
reaction conditions and the resulting particles can be
made.

-10-

Increasing the laser power results in increased reaction temperatures in the reaction region as well as a faster quenching rate. A rapid quenching rate tends to favor production of high energy phases, which may not be obtained with processes near thermal equilibrium. Similarly, increasing the chamber pressure also tends to favor the production of higher energy structures. Also, increasing the concentration of the reactant serving as an oxygen source in the reactant stream favors the production of particles with increased amounts of oxygen.

Reactant flow rate and velocity of the reactant gas stream are inversely related to particle size so that increasing the reactant gas flow rate or velocity tends to result in smaller particle sizes. Also, the growth dynamics of the particles have a significant influence on the size of the resulting particles. In other words, different forms of a product compound have a tendency to form different size particles from other phases under relatively similar conditions. Light intensity/laser power also influences particle size with increased light intensity favoring larger particle formation for lower melting materials and smaller particle formation for higher melting materials.

Laser pyrolysis has been performed generally with gas/vapor phase reactants. In addition, for carbon production by laser pyrolysis, a small amount of iron carbonyl ($\text{Fe}(\text{CO})_5$) may function as a catalyst for the pyrolysis of benzene. Many metal/silicon precursor compounds can be delivered into the reaction chamber as a gas. Appropriate metal/silicon precursor compounds for gaseous delivery generally include metal/silicon compounds with reasonable vapor pressures, i.e., vapor

-11-

pressures sufficient to get desired amounts of precursor gas/vapor into the reactant stream. The vessel holding liquid or solid precursor compounds can be heated to increase the vapor pressure of the metal/silicon precursor, if desired.

A carrier gas can be bubbled through a liquid precursor to facilitate delivery of a desired amount of precursor vapor. Suitable liquid, aluminum precursors with sufficient vapor pressure of gaseous delivery include, for example, aluminum s-butoxide ($\text{Al}(\text{OC}_4\text{H}_9)_3$). Suitable silicon precursors include, for example, silicon tetrachloride (SiCl_4), trichlorosilane (Cl_3HSi), trichloromethyl silane CH_3SiCl_3 , and tetraethoxysilane ($\text{Si}(\text{OC}_2\text{H}_5)_4$, also known as ethyl silane and tetraethyl silane).

A number of suitable solid, aluminum precursor compounds are available including, for example, aluminum chloride (AlCl_3), aluminum ethoxide ($\text{Al}(\text{OC}_2\text{H}_5)_3$), and aluminum isopropoxide ($\text{Al}[\text{OCH}(\text{CH}_3)_2]_3$). Solid precursors generally are heated to produce a sufficient vapor pressure. A carrier gas can be passed over the solid precursor to facilitate delivery of the precursor vapor. A suitable container for heating and delivering of a solid precursor to a laser pyrolysis apparatus is described below.

The use of exclusively gas phase reactants is somewhat limiting with respect to the types of precursor compounds that can be used conveniently. Thus, techniques have been developed to introduce aerosols containing reactant precursors into laser pyrolysis chambers. Improved aerosol delivery apparatuses for reaction systems are described further in commonly assigned and copending U.S. Patent Application Serial Number 09/188,670 to Gardner et al., entitled "Reactant

-12-

Delivery Apparatuses," filed November 9, 1998, incorporated herein by reference.

Using aerosol delivery apparatuses, solid precursor compounds can be delivered by dissolving the compounds in a solvent. Alternatively, powdered precursor compounds can be dispersed in a liquid/solvent for aerosol delivery. Liquid precursor compounds can be delivered as an aerosol from a neat liquid, a multiple liquid dispersion or a liquid solution. Aerosol reactants can be used to obtain a significant reactant throughput. A solvent/dispersant can be selected to achieve desired properties of the resulting solution/dispersion. Suitable solvents include water, methanol, ethanol, isopropyl alcohol, other organic solvents and mixtures thereof. The solvent should have a desired level of purity such that the resulting particles have a desired purity level. Some solvents, such as isopropyl alcohol, are significant absorbers of infrared light from a CO₂ laser such that no additional laser absorbing compound may be needed within the reactant stream if a CO₂ laser is used as a light source.

If aerosol precursors are formed with a solvent present, the solvent preferably is rapidly evaporated by the light beam in the reaction chamber such that a gas phase reaction can take place. Thus, the fundamental features of the laser pyrolysis reaction are unchanged by the presence of an aerosol. Nevertheless, the reaction conditions are affected by the presence of the aerosol. Below in the Examples, conditions are described for the production of manganese oxide nanoparticles using aerosol precursors in a particular laser pyrolysis reaction chamber. Thus, the

-13-

parameters associated with aerosol reactant delivery can be explored further based on the description below.

A number of suitable solid, metal/silicon precursor compounds can be delivered as an aerosol from
5 solution. The compounds are dissolved in a solution preferably with a concentration greater than about 0.5 molar. Generally, the greater the concentration of precursor in the solution the greater the throughput of reactant through the reaction chamber. As the
10 concentration increases, however, the solution can become more viscous such that the aerosol may have droplets with larger sizes than desired. Thus, selection of solution concentration can involve a balance of factors in the selection of a preferred
15 solution concentration.

Preferred secondary reactants serving as an oxygen source include, for example, O₂, CO, CO₂, O₃ and mixtures thereof. Oxygen can be supplied as air. The secondary reactant compound should not react
20 significantly with the metal/silicon precursor prior to entering the reaction zone since this generally would result in the formation of large particles.

Laser pyrolysis can be performed with a variety of optical frequencies. Preferred light sources
25 operate in the infrared portion of the electromagnetic spectrum. CO₂ lasers are particularly preferred sources of light. Infrared absorbers for inclusion in the reactant stream include, for example, C₂H₄, isopropyl alcohol, NH₃, SF₆, SiH₄ and O₃. O₃ can act as both an
30 infrared absorber and as an oxygen source. The radiation absorber, such as the infrared absorber, absorbs energy from the radiation beam and distributes the energy to the other reactants to drive the pyrolysis.

-14-

Preferably, the energy absorbed from the light beam increases the temperature at a tremendous rate, many times the rate that heat generally would be produced by exothermic reactions under controlled condition. While the process generally involves nonequilibrium conditions, the temperature can be described approximately based on the energy in the absorbing region. The laser pyrolysis process is qualitatively different from the process in a combustion reactor where an energy source initiates a reaction, but the reaction is driven by energy given off by an exothermic reaction. Thus, while this light driven process is referred to as laser pyrolysis, it is not a thermal process even though traditional pyrolysis is a thermal process.

An inert shielding gas can be used to reduce the amount of reactant and product molecules contacting the reactant chamber components. Inert gases can also be introduced into the reactant stream as a carrier gas and/or as a reaction moderator. Appropriate inert shielding gases include, for example, Ar, He and N₂.

An appropriate laser pyrolysis apparatus generally includes a reaction chamber isolated from the ambient environment. A reactant inlet connected to a reactant delivery apparatus produces a reactant stream through the reaction chamber. A laser beam path intersects the reactant stream at a reaction zone. The reactant/product stream continues after the reaction zone to an outlet, where the reactant/product stream exits the reaction chamber and passes into a collection apparatus. Generally, the light source, such as a laser, is located external to the reaction chamber, and the light beam enters the reaction chamber through an appropriate window.

-15-

Referring to Fig. 1, a particular embodiment 100 of a laser pyrolysis system involves a reactant delivery apparatus 102, reaction chamber 104, shielding gas delivery apparatus 106, collection apparatus 108 and light source 110. Alternative designs can be used for reaction delivery apparatuses 102 with the apparatus of Fig. 1. A first reaction delivery apparatus described below can be used to deliver exclusively gaseous reactants. Two alternative reactant delivery apparatuses are described for delivery of one or more reactants as an aerosol.

Referring to Fig. 2, a first embodiment 112 of reactant delivery apparatus 102 includes a source 120 of a precursor compound. For liquid or solid reactants, a carrier gas from one or more carrier gas sources 122 can be introduced into precursor source 120 to facilitate delivery of the reactant. Precursor source 120 can be a liquid holding container, a solid precursor delivery apparatus, as described below, or other suitable container. The carrier gas from carrier gas source 122 preferably is either an infrared absorber and/or an inert gas. Carrier gas preferably is bubbled through a liquid reactant compound or delivered into a solid reactant delivery apparatus. The quantity of reactant vapor in the reaction zone is roughly proportional to the flow rate of the carrier gas. A liquid or solid reactant can be heated to increase its vapor pressure. Similarly, portions of reactant delivery apparatus 102 can be heated to inhibit the deposition of reactant compound on the walls of the delivery apparatus.

Alternatively, carrier gas can be supplied directly from infrared absorber source 124 and/or inert gas source 126, as appropriate. The gases from precursor source 120 are mixed with gases from infrared

-16-

absorber source 124 and/or inert gas source 126 by combining the gases in a single portion of tubing 128. The gases are combined a sufficient distance from reaction chamber 104 such that the gases become well
5 mixed prior to their entrance into reaction chamber 104. The combined gas in tube 128 passes through a duct 130 into channel 132, which is in fluid communication with reactant inlet 134, which can be part of a multiple inlet delivery apparatus, as shown in phantom lines in
10 Fig. 2.

A second reactant can be supplied from second reactant source 138, which can be a liquid reactant delivery apparatus, a solid reactant delivery apparatus, a gas cylinder or other suitable container or
15 containers. If second reactant source 138 delivers a liquid or solid reactant, carrier gas from carrier gas source 122 or an alternative carrier gas source can be used to facilitate delivery of the reactant. As shown in Fig. 2, second reactant source 138 delivers a second
20 reactant to duct 130 by way of tube 128. Alternatively, second reactant source 138 can deliver the second reactant to tube 140 for delivery through duct 142 to a second reactant inlet 144, as depicted with phantom lines in Fig. 2. Inlets 134, 144 can be angled slightly
25 toward each other to facilitate mixing of the gases.

With alternative delivery through reactant inlets 134 and 144, the first and second reactants are mixed within the reaction chamber after exiting from the reactant inlets. This is particularly advantageous if
30 the reactants spontaneously react. If more than two reactants are used, the additional reactants can similarly be delivered through a single reactant inlet 134, through two inlets 134, 144, or through more than two reactant inlets, as appropriate. Mass flow

-17-

controllers 146 can be used to regulate the flow of gases within the reactant delivery system of Fig. 2.

Referring to Fig. 3, the solid precursor delivery apparatus 150 for vapor delivery includes a container 152 and a lid 154. A gasket 156 is located between container 152 and lid 154. In one preferred embodiment, container 152 and lid 154 are made from stainless steel, and gasket 156 is made from copper. In this embodiment, lid 154 and gasket 156 are bolted to container 152. Other inert materials, such as Pyrex[®], suitable for the temperatures and pressures applied to the solid precursor system can be used. Container 152 is surrounded with a band heater 158, which is used to set the temperature of the delivery apparatus 150 at desired values. Suitable band heaters are available from Omega Engineering Inc. Stamford, Conn. The temperature of the band heater can be adjusted to yield a desired vapor pressure of the precursor compound. Additional portions of the precursor delivery system can be heated to maintain the precursor in a vapor state after it has left container 152.

Preferably, a thermocouple 160 is inserted into container 152 through lid 154. Thermocouple 160 can be inserted by way of a Swagelok[®] fitting 162 or other suitable connection. Tubing 164 provides a input flow of a carrier gas into container 152. Tubing 164 preferably includes a shut off valve 166 and can be inserted through lid 154 by way of a Swagelok[®] fitting 168 or other suitable connection. Output tube 170 also preferably includes a shut off valve 172. Output tube 170 preferably enters into container 152 through lid 154 at a sealed connection 174. Tubes 164 and 170 can be made of any suitable inert material such as stainless steel. A solid precursor can be placed directly within

-18-

container 152 or it can be placed within a smaller, open container within container 152.

As noted above, the reactant stream can include one or more aerosols. The aerosols can be formed within reaction chamber 104 or outside of reaction chamber 104 prior to injection into reaction chamber 104. If the aerosols are produced prior to injection into reaction chamber 104, the aerosols can be introduced through reactant inlets comparable to those used for gaseous reactants, such as reactant inlet 134 in Fig. 2.

Referring to Fig. 4, an alternative embodiment 180 of the reactant supply system 102 is used to supply an aerosol to channel 132. As described above, channel 132 forms part of an injection nozzle for directing reactants into the reaction chamber and terminates at reactant inlet 134. Reactant supply system 180 includes an aerosol generator 182, carrier gas/vapor supply tube 184 and junction 186. Channel 132, aerosol generator 182 and supply tube 184 meet within interior volume 188 of junction 186. Supply tube 184 is oriented to direct carrier gas along channel 132. Aerosol generator 182 is mounted such that an aerosol 190 is generated in the interior volume 188 of junction 186 between the opening into channel 134 and the outlet from supply tube 184.

Aerosol generator 182 can operate based on a variety of principles. For example, the aerosol can be produced with an ultrasonic nozzle, with an electrostatic spray system, with a pressure-flow or simplex atomizer, with an effervescent atomizer or with a gas atomizer where liquid is forced under significant pressure through a small orifice and fractured into particles by a colliding gas stream. Suitable ultrasonic nozzles can include piezoelectric

-19-

transducers. Ultrasonic nozzles with piezoelectric transducers and suitable broadband ultrasonic generators are available from Sono-Tek Corporation, Milton, NY, such as model 8700-120. Suitable aerosol generators are described further in copending and commonly assigned, U.S. Patent Application Serial No. 09/188,670 to Gardner et al., entitled "REACTANT DELIVERY APPARATUSES," incorporated herein by reference. Additional aerosol generators can be attached to junction 186 through other ports 192 such that additional aerosols can be generated in interior volume 188 for delivery into the reaction chamber.

Junction 186 includes ports 192 to provide access from outside junction 186 to interior 188. Thus, channel 132, aerosol generator 182 and supply tube 184 can be mounted appropriately. In one embodiment, junction 186 is cubic with six cylindrical ports 192, with one port 192 extending from each face of junction 186. Junction 186 can be made from stainless steel or other durable, noncorrosive material. A window 194 preferably is sealed at one port 192 to provide for visual observation into interior 188. The port 192 extending from the bottom of junction 186 preferably includes a drain 196, such that condensed aerosol that is not delivered through channel 134 can be removed from junction 186.

Carrier gas/vapor supply tube 184 is connected to gas source 198. Gas source 198 can include one or a plurality of gas containers that are connected to deliver a selected gas or gas mixture to supply tube 184. Carrier gas can be passed through a liquid precursor delivery apparatus or a solid precursor delivery apparatus, such that the carrier gas includes vapor of a liquid precursor or a solid precursor.

-20-

Thus, carrier gas/vapor supply tube 184 can be used to deliver a variety of desired gases and/or vapors within the reactant stream including, for example, laser absorbing gases, reactants, and/or inert gases. The flow of gas from gas source 198 to supply tube 184 preferably is controlled by one or more mass flow controllers 200 or the like. Liquid supply tube 202 is connected to aerosol generator 182 and to liquid supply 204. For the production of nanoscale particles, liquid supply 204 can hold a liquid comprising a metal/silicon precursor.

In the embodiment shown in Fig. 4, aerosol generator 182 generates an aerosol with momentum roughly orthogonal to the carrier gas flow from tube 184 to channel 132. Thus, carrier gas/vapor from supply tube 184 directs aerosol precursor generated by aerosol generator 182 into channel 132. In operation, carrier gas flow directs the aerosol delivered within interior volume 188 into channel 132. In this way, the delivery velocity of the aerosol is determined effectively by the flow rate of the carrier gas.

In alternative preferred embodiments, the aerosol generator is placed at an upward angle relative to the horizontal, such that a component of the forward momentum of the aerosol is directed along channel 134. In a preferred embodiment, the output directed from the aerosol generator is placed at about a 45° angle relative to the normal direction defined by the opening into channel 134, i.e. the direction of the flow into channel 134 from supply tube 184.

Referring to Fig. 5, another embodiment 210 of the reactant supply system 102 can be used to supply an aerosol to duct 132. Reactant supply system 210 includes an outer nozzle 212 and an inner nozzle 214.

-21-

Outer nozzle 212 has an upper channel 216 that leads to a rectangular outlet 218 at the top of outer nozzle 212, as shown in the insert in Fig. 5. Rectangular nozzle has selected dimensions to produce a reactant stream of
5 desired expanse within the reaction chamber. Outer nozzle 212 includes a drain tube 220 in base plate 222. Drain tube 220 is used to remove condensed aerosol from outer nozzle 212. Inner nozzle 214 is secured to outer nozzle 212 at fitting 224.

10 Inner nozzle 214 can be a gas atomizer, such as a gas atomizer from Spraying Systems (Wheaton, IL), for example, model number 17310-12-1x8jj. This model gas atomizer has about a 0.5 inch diameter and a 12.0 inch length. The top of the nozzle preferably is a twin
15 orifice internal mix atomizer 226 (for example, 0.055 in. gas orifice and 0.005 in. liquid orifice). Liquid is fed to the atomizer through tube 228, and gases for introduction into the reaction chamber are fed to the atomizer through tube 230. Interaction of the gas with
20 the liquid assists with droplet formation.

Outer nozzle 212 and inner nozzle 214 are assembled concentrically. Outer nozzle 212 shapes the aerosol generated by inner nozzle 214 such that it has a flat rectangular cross section. In addition, outer
25 nozzle 212 helps to achieve a uniform aerosol velocity and a uniform aerosol distribution along the cross section. Outer nozzle 212 can be reconfigured for different reaction chambers. The height of outer nozzle 212 relative to the light beam can be adjusted to
30 produce spray characteristics that result in desired particle properties, with a three inch separation between outer nozzle 212 and the light beam being suitable for some embodiments.

-22-

The reaction chamber 104 includes a main chamber 250. Reactant supply system 102 connects to the main chamber 250 at injection nozzle 252. Reaction chamber 104 can be heated to a surface temperature above
5 the dew point of the mixture of reactants and inert components at the pressure in the apparatus.

The end of injection nozzle 252 has an annular opening 254 for the passage of inert shielding gas, and a reactant inlet 256 (left lower insert) or inlets 256,
10 258 (right lower insert) for the passage of reactants to form a reactant stream in the reaction chamber. Reactant inlets 256, 258 preferably are slits, as shown in the lower inserts of Fig. 1. Annular opening 254 has, for example, a diameter of about 1.5 inches and a
15 width along the radial direction from about 1/8 in to about 1/16 in. The flow of shielding gas through annular opening 254 helps to prevent the spread of the reactant gases and product particles throughout reaction chamber 104.

Tubular sections 260, 262 are located on either side of injection nozzle 252. Tubular sections 260, 262 include ZnSe windows 264, 266, respectively. Windows 264, 266 are about 1 inch in diameter. Windows 264, 266 are preferably cylindrical lenses with a focal
25 length equal to the distance between the center of the chamber to the surface of the lens to focus the light beam to a point just below the center of the nozzle opening. Windows 264, 266 preferably have an antireflective coating. Appropriate ZnSe lenses are
30 available from Laser Power Optics, San Diego, California. Tubular sections 260, 262 provide for the displacement of windows 264, 266 away from main chamber 250 such that windows 264, 266 are less likely to be contaminated by reactants and/or products. Window 264,

-23-

266 are displaced, for example, about 3 cm from the edge of the main chamber 250.

Windows 264, 266 are sealed with a rubber o-ring to tubular sections 260, 262 to prevent the flow of ambient air into reaction chamber 104. Tubular inlets 268, 270 provide for the flow of shielding gas into tubular sections 260, 262 to reduce the contamination of windows 264, 266. Tubular inlets 268, 270 are connected to shielding gas delivery apparatus 106.

Referring to Fig. 1, shielding gas delivery system 106 includes inert gas source 280 connected to an inert gas duct 282. Inert gas duct 282 flows into annular channel 284 leading to annular opening 254. A mass flow controller 286 regulates the flow of inert gas into inert gas duct 282. If reactant delivery system 112 of Fig. 2 is used, inert gas source 126 can also function as the inert gas source for duct 282, if desired. Referring to Fig. 1, inert gas source 280 or a separate inert gas source can be used to supply inert gas to tubes 268, 270. Flow to tubes 268, 270 preferably is controlled by a mass flow controller 288.

Light source 110 is aligned to generate a light beam 300 that enters window 264 and exits window 266. Windows 264, 266 define a light path through main chamber 250 intersecting the flow of reactants at reaction zone 302. After exiting window 266, light beam 300 strikes power meter 304, which also acts as a beam dump. An appropriate power meter is available from Coherent Inc., Santa Clara, CA. Light source 110 can be a laser or an intense conventional light source such as an arc lamp. Preferably, light source 110 is an infrared laser, especially a CW CO₂ laser such as an 1800 watt maximum power output laser available from PRC Corp., Landing, NJ.

-24-

Reactants passing through reactant inlet 256 in injection nozzle 252 initiate a reactant stream. The reactant stream passes through reaction zone 302, where reaction involving the metal precursor compounds takes place. Heating of the gases in reaction zone 302 is extremely rapid, roughly on the order of 10^5 degree C/sec depending on the specific conditions. The reaction is rapidly quenched upon leaving reaction zone 302, and particles 306 are formed in the reactant/product stream. The nonequilibrium nature of the process allows for the production of nanoparticles with a highly uniform size distribution and structural homogeneity.

The path of the reactant stream continues to collection nozzle 310. In a preferred embodiment, collection nozzle 310 is spaced about 2 cm from injection nozzle 252. The small spacing between injection nozzle 252 and collection nozzle 310 helps reduce the contamination of reaction chamber 104 with reactants and products. Collection nozzle 310 has a circular opening 312, as shown in the upper insert of Fig. 1. Circular opening 312 feeds into collection system 108.

The chamber pressure is monitored with a pressure gauge 320 attached to the main chamber. The preferred chamber pressure for the production of the desired nanoparticles generally ranges from about 80 Torr to about 650 Torr.

Reaction chamber 104 has two additional tubular sections not shown. One of the additional tubular sections projects into the plane of the sectional view in Fig. 1, and the second additional tubular section projects out of the plane of the sectional view in Fig. 1. When viewed from above, the

-25-

four tubular sections are distributed roughly, symmetrically around the center of the chamber. These additional tubular sections have windows for observing the inside of the chamber. In this configuration of the apparatus, the two additional tubular sections are not used directly to facilitate production of particles.

Collection system 108 preferably includes a curved channel 330 leading from collection nozzle 310. Because of the small size of the particles, the product particles follow the flow of the gas around curves. Collection system 108 includes a filter 332 within the gas flow to collect the product particles. Due to curved section 330, the filter is not supported directly above the chamber. A variety of materials such as Teflon[®] (polytetrafluoroethylene), glass fibers and the like can be used for the filter as long as the material is inert and has a fine enough mesh to trap the particles. Preferred materials for the filter include, for example, a glass fiber filter from ACE Glass Inc., Vineland, NJ and cylindrical Nomex[®] filters from AF Equipment Co., Sunnyvale, CA.

Pump 334 is used to maintain collection system 108 at a selected pressure. A variety of different pumps can be used. Appropriate pumps for use as pump 334 include, for example, Busch Model B0024 pump from Busch, Inc., Virginia Beach, VA with a pumping capacity of about 25 cubic feet per minute (cfm) and Leybold Model SV300 pump from Leybold Vacuum Products, Export, PA with a pumping capacity of about 195 cfm. It may be desirable to flow the exhaust of the pump through a scrubber 336 to remove any remaining reactive chemicals before venting into the atmosphere. The entire apparatus 100 can be placed in a fume hood for ventilation purposes and for safety considerations.

-26-

Generally, the laser remains outside of the fume hood because of its large size.

The pumping rate is controlled by either a manual needle valve or an automatic throttle valve 338 inserted between pump 334 and filter 332. As the chamber pressure increases due to the accumulation of particles on filter 332, the manual valve or the throttle valve can be adjusted to maintain the pumping rate and the corresponding chamber pressure.

The apparatus is controlled by a computer 350. Generally, the computer controls the light source and monitors the pressure in the reaction chamber. The computer can be used to control the flow of reactants and/or the shielding gas.

The reaction can be continued until sufficient particles are collected on filter 332 such that pump 334 can no longer maintain the desired pressure in the reaction chamber 104 against the resistance through filter 332. When the pressure in reaction chamber 104 can no longer be maintained at the desired value, the reaction is stopped, and filter 332 is removed. With this embodiment, about 1-300 grams of particles can be collected in a single run before the chamber pressure can no longer be maintained. A single run generally can last up to about 10 hours depending on the reactant delivery system, the type of particle being produced and the type of filter being used.

The reaction conditions can be controlled relatively precisely. In particular, the mass flow controllers are quite accurate. The laser generally has about 0.5 percent power stability. With either a manual control or a throttle valve, the chamber pressure can be controlled to within about 1 percent.

-27-

The configuration of the reactant supply system 102 and the collection system 108 can be reversed. In this alternative configuration, the reactants are supplied from the top of the reaction chamber, and the product particles are collected from the bottom of the chamber. In the alternative configuration, the collection system may not include a curved section so that the collection filter is mounted directly below the reaction chamber.

10 An alternative design of a laser pyrolysis apparatus has been described in U.S. Patent 5,958,348 to Bi et al., entitled "Efficient Production of Particles by Chemical Reaction," incorporated herein by reference. This alternative design is intended to facilitate production of commercial quantities of particles by laser pyrolysis. Additional embodiments and other appropriate features for commercial capacity laser pyrolysis apparatuses are described in copending and commonly assigned U.S. Patent Application Serial No. 15 09/362,631, entitled "Particle Production Apparatus," incorporated herein by reference.

In one preferred embodiment of a commercial capacity laser pyrolysis apparatus, the reaction chamber is elongated along the light beam to provide for an increase in the throughput of reactants and products. The original design of the apparatus was based on the introduction of purely gaseous reactants. The embodiments described above for the delivery of aerosol reactants can be adapted for the elongated reaction chamber design. Additional embodiments for the introduction of an aerosol with one or more aerosol generators into an elongated reaction chamber is described in commonly assigned and copending U.S. Patent application serial No. 09/188,670 to Gardner et al.,

-28-

entitled "Reactant Delivery Apparatuses," incorporated herein by reference.

In general, the laser pyrolysis apparatus with the elongated reaction chamber is designed to reduce contamination of the chamber walls, to increase the production capacity and to make efficient use of resources. To accomplish these objectives, the elongated reaction chamber provides for an increased throughput of reactants and products without a corresponding increase in the dead volume of the chamber. The dead volume of the chamber can become contaminated with unreacted compounds and/or reaction products. Furthermore, an appropriate flow of shielding gas confines the reactants and products within a flow stream through the reaction chamber. The high throughput of reactants makes efficient use of the laser energy.

The design of the improved reaction chamber 400 is shown schematically in Fig. 6. A reactant inlet 402 leads to main chamber 404. Reactant inlet 402 conforms generally to the shape of main chamber 404. Main chamber 404 includes an outlet 406 along the reactant/product stream for removal of particulate products, any unreacted gases and inert gases. Shielding gas inlets 410 are located on both sides of reactant inlet 402. Shielding gas inlets are used to form a blanket of inert gases on the sides of the reactant stream to inhibit contact between the chamber walls and the reactants or products.

Tubular sections 420, 422 extend from the main chamber 404. Tubular sections 420, 422 hold windows 424, 426 to define a light beam path 428 through the reaction chamber 400. Tubular sections 420, 422 can

-29-

include inert gas inlets 430, 432 for the introduction of inert gas into tubular sections 420, 422.

The improved reaction system includes a collection apparatus to remove the nanoparticles from the reactant stream. The collection system can be designed to collect particles in a batch mode with the collection of a large quantity of particles prior to terminating production. Alternatively, the collection system can be designed to run in a continuous production mode by switching between different particle collectors within the collection apparatus or by providing for removal of particles without exposing the collection system to the ambient atmosphere. An preferred embodiment of a collection apparatus for continuous particle production is described in copending and commonly assigned U.S. Patent application serial number 09/107,729 to Gardner et al., entitled "Particle Collection Apparatus And Associated Methods," incorporated herein by reference. The collection apparatus can include curved components within the flow path similar to curved portion of the collection apparatus shown in Fig. 1.

Referring to Fig. 7, a specific embodiment 450 of a laser pyrolysis reaction system with an elongated reaction chamber is shown. In this embodiment, the reaction chamber can be used with a reaction delivery apparatus designed for the delivery of only gaseous reactants or with an reactant delivery apparatus that can deliver aerosol reactants along with any desired gases. Laser pyrolysis reaction apparatus 450 includes reaction chamber 452, a particle collection apparatus 454, light source 456 and a reactant delivery system attached at inlet 464.

-30-

Reaction chamber 452 includes inlet 464 at the bottom of reaction chamber 452 where the reactant delivery apparatus connects with reaction chamber 452. Nozzles associated with the reactant delivery apparatus can extend into reaction chamber 452 and seal from the ambient atmosphere at inlet 464. Gaseous reactants can be delivered through a nozzle elongated to conform generally to the elongation of reaction chamber 452. Similarly, aerosols can be delivered to account for the elongated shape of the reaction chamber.

In this embodiment, the reactants are delivered from the bottom of reaction chamber 452 while the products are collected from the top of reaction chamber 452. The configuration can be reversed with the reactants supplied from the top and product collected from the bottom, as shown schematically in Fig. 6. Shielding gas conduits can be located in appropriate positions around the reactant delivery nozzle extending into reactant inlet 464. The shielding gas conduits direct shielding gas along the walls of reaction chamber 452 to inhibit association of reactant gases or products with the walls.

Reaction chamber 452 is elongated along one dimension denoted in Fig. 7 by "w". A laser beam path 466 enters reaction chamber 452 through a window 468 displaced along a tube 470 from main chamber 472 and traverses the elongated direction of reaction chamber 452. The laser beam passes through tube 474 and exits window 476. In one preferred embodiment, tubes 470 and 474 displace windows 468 and 476 about 11 inches from main chamber 472. The laser beam terminates at beam dump 478. In operation, the laser beam intersects a reactant stream generated from the nozzle inserted through reactant inlet 464.

-31-

The top of main chamber 472 opens into particle collection system 454. Particle collection system 454 includes outlet duct 480 connected to the top of main chamber 472 to receive the flow from main chamber 472. Outlet duct 480 carries the product particles out of the plane of the reactant stream to a cylindrical filter 482, as shown in Fig. 8. Filter 482 has a cap 484 on one end to block direct flow into the center of filter 482. The other end of filter 482 is fastened to disc 486. Vent 488 is secured to the center of disc 486 to provide access to the center of filter 482. Vent 488 is attached by way of ducts to a pump.

Thus, product particles are trapped on filter 482 by the flow from the reaction chamber 452 to the pump. Suitable pumps were described above with respect to the first laser pyrolysis apparatus in Fig. 1. Suitable filters for use as filter 482 include, for example, an air cleaner filter for a Saab 9000 automobile (Purilator part A44-67), which is wax impregnated paper with a Plasticol™ or polyurethane end cap 484.

The collection apparatus shown in Figs. 7 and 8 is suitable for the operation of reaction chamber 452 in batch mode, where operation is stopped when filter 482 can no longer collect additional particles. Alternative collection apparatuses are suitable for operating reaction chamber 452 in continuous operation, as described above. The dimensions of elongated reaction chamber 452 and reactant inlet 464 preferably are designed for high efficiency particle production. Reasonable dimensions for reactant inlet 464 for the production of nanoparticles, when used with a 1800 watt CO₂ laser, are from about 5 mm to about 1 meter.

B. Heat Treatment of Nanoparticles

-32-

As noted above, properties of nanoparticles can be modified by heat processing. Suitable starting material for the heat treatment include nanoparticles produced by laser pyrolysis. In addition, nanoparticles used as starting material can have been subjected to one or more prior heating steps under different conditions. For the heat processing of nanoparticles formed by laser pyrolysis, the additional heat processing can improve the crystallinity, remove contaminants, such as elemental carbon, and possibly alter the stoichiometry, for example, by incorporation of additional oxygen or of atoms from other gaseous or nongaseous compounds.

The nanoparticles are preferably heated in an oven or the like to provide generally uniform heating. The processing conditions generally are mild, such that significant amounts of particle sintering does not occur. Thus, the temperature of heating preferably is low relative to the melting point of both the starting material and the product material.

The atmosphere over the particles can be static, or gases can be flowed through the system. The atmosphere for the heating process can be an oxidizing atmosphere or an inert atmosphere. In particular, for conversion of amorphous particles to crystalline particles or from one crystalline structure to a different crystalline structure of essentially the same stoichiometry, the atmosphere generally can be inert.

Appropriate oxidizing gases include, for example, O_2 , O_3 , CO , CO_2 , and combinations thereof. The O_2 can be supplied as air. Oxidizing gases optionally can be mixed with inert gases such as Ar, He and N_2 . When inert gas is mixed with the oxidizing gas, the gas mixture can include from about 1 percent oxidizing gas to about 99 percent oxidizing gas, and more preferably

-33-

from about 5 percent oxidizing gas to about 99 percent oxidizing gas. Alternatively, either essentially pure oxidizing gas or pure inert gas can be used, as desired.

The precise conditions can be altered to vary
5 the type of nanoparticles that are produced. For example, the temperature, time of heating, heating and cooling rates, the gases and the exposure conditions with respect to the gases can all be selected to produce desired product particles. Generally, while heating
10 under an oxidizing atmosphere, the longer the heating period the more oxygen that is incorporated into the material, prior to reaching equilibrium. Once equilibrium conditions are reached, the overall conditions determine the crystalline phase of the
15 powders.

A variety of ovens or the like can be used to perform the heating. An example of an apparatus 500 to perform this processing is displayed in Fig. 9. Apparatus 500 includes a jar 502, which can be made from
20 glass or other inert material, into which the particles are placed. Suitable glass reactor jars are available from Ace Glass (Vineland, NJ). The top of glass jar 502 is sealed to a glass cap 504, with a Teflon® gasket 506 between jar 502 and cap 504. Cap 504 can be held in
25 place with one or more clamps. Cap 504 includes a plurality of ports 508, each with a Teflon® bushing. A multiblade stainless steel stirrer 510 preferably is inserted through a central port 508 in cap 504. Stirrer 510 is connected to a suitable motor.

30 One or more tubes 512 are inserted through ports 508 for the delivery of gases into jar 502. Tubes 512 can be made from stainless steel or other inert material. Diffusers 514 can be included at the tips of tubes 512 to disburse the gas within jar 502. A

-34-

heater/furnace 516 generally is placed around jar 502. Suitable resistance heaters are available from Glas-col (Terre Haute, IN). One port preferably includes a T-connection 518. The temperature within jar 502 can be measured with a thermocouple 518 inserted through T-connection 518. T-connection 518 can be further connected to a vent 520. Vent 520 provides for the venting of gas circulated through jar 502. Preferably vent 520 is vented to a fume hood or alternative ventilation equipment.

Preferably, desired gases are flowed through jar 502. Tubes 512 generally are connected to an oxidizing gas source and/or an inert gas source. Oxidizing gas, inert gas or a combination thereof to produce the desired atmosphere are placed within jar 502 from the appropriate gas source(s). Various flow rates can be used. The flow rate preferably is between about 1 standard cubic centimeters per minute (sccm) to about 1000 sccm and more preferably from about 10 sccm to about 500 sccm. The flow rate generally is constant through the processing step, although the flow rate and the composition of the gas can be varied systematically over time during processing, if desired. Alternatively, a static gas atmosphere can be used.

For the processing of nanoparticles of many of the materials described herein, the temperature generally ranges from about 50°C to about 600°C and in most circumstances from about 60°C to about 400°C. The heating generally is continued for greater than about 5 minutes, and typically is continued for from about 2 hours to about 120 hours, in most circumstances from about 2 hours to about 25 hours. Preferred heating temperatures and times will depend on the particular starting material and target product. Some empirical

-35-

adjustment may be required to produce the conditions appropriate for yielding a desired material. The use of mild conditions avoids interparticle sintering resulting in larger particle sizes. Some controlled sintering of the particles can be performed at somewhat higher temperatures to produce slightly larger, average particle diameters.

The conditions to convert crystalline VO_2 to orthorhombic V_2O_5 and 2-D crystalline V_2O_5 , and amorphous V_2O_5 to orthorhombic V_2O_5 and 2-D crystalline V_2O_5 are described in copending and commonly assigned U.S. Patent application serial number 08/897,903, to Bi et al., entitled "Processing of Vanadium Oxide Particles With Heat," incorporated herein by reference. Conditions for the removal of carbon coatings from metal oxide nanoparticles is described in U.S. Patent Application Serial No. 09/123,255, entitled "Metal (Silicon) Oxide/Carbon Composite Particles," incorporated herein by reference. The incorporation of lithium from a lithium salt into metal oxide nanoparticles in a heat treatment process is described in copending and commonly assigned U.S. Patent Application Serial No. 09/311,506, entitled "Metal Vanadium Oxide Particles," incorporated herein by reference.

C. Properties of the Particles

A collection of particles of interest generally has an average diameter for the primary particles of less than about 500 nm, preferably from about 5 nm to about 100 nm, more preferably from about 5 nm to about 75 nm, and even more preferably from about 5 nm to about 50 nm. Particle diameters are evaluated by transmission electron microscopy. Preferred particles comprise elemental carbon, an elemental metal,

-36-

a metal/silicon oxide, a metal/silicon nitride or a metal/silicon carbide.

The primary particles usually have a roughly spherical gross appearance. Upon closer examination, crystalline particles generally have facets corresponding to the underlying crystal lattice. Nevertheless, crystalline primary particles tend to exhibit growth that is roughly equal in the three physical dimensions to give a gross spherical appearance. Amorphous particles generally have an even more spherical aspect. In preferred embodiments, 95 percent of the primary particles, and preferably 99 percent, have ratios of the dimension along the major axis to the dimension along the minor axis less than about 2. Diameter measurements on particles with asymmetries are based on an average of length measurements along the principle axes of the particle.

Because of their small size, the primary particles tend to form loose agglomerates due to van der Waals and other electromagnetic forces between nearby particles. These agglomerates can be dispersed to a significant degree, as described further below. The secondary or agglomerated particle size depends on the subsequent processing of the particles following their initial formation and the composition and structure of the particles. In preferred embodiments, the secondary particles have an average diameter from about 20 nm to about 400 nm.

Even though the particles form loose agglomerates, the nanometer scale of the primary particles is clearly observable in transmission electron micrographs of the particles. The particles generally have a surface area corresponding to particles on a nanometer scale as observed in the micrographs.

-37-

Furthermore, the particles can manifest unique properties due to their small size and large surface area per weight of material. For example, vanadium oxide nanoparticles can exhibit surprisingly high energy densities in lithium batteries, as described in U.S. Patent 5,952,125 to Bi et al., entitled "Batteries With Electroactive Nanoparticles," incorporated herein by reference.

The primary particles preferably have a high degree of uniformity in size. Laser pyrolysis, as described above, generally results in particles having a very narrow range of particle diameters. Furthermore, heat processing under suitably mild conditions does not alter the very narrow range of particle diameters. With aerosol delivery of reactants for laser pyrolysis, the distribution of particle diameters is particularly sensitive to the reaction conditions. Nevertheless, if the reaction conditions are properly controlled, a very narrow distribution of particle diameters can be obtained with an aerosol delivery system. As determined from examination of transmission electron micrographs, the primary particles generally have a distribution in sizes such that at least about 95 percent, and preferably 99 percent, of the primary particles have a diameter greater than about 40 percent of the average diameter and less than about 160 percent of the average diameter. Preferably, the primary particles have a distribution of diameters such that at least about 95 percent, and preferably 99 percent, of the primary particles have a diameter greater than about 60 percent of the average diameter and less than about 140 percent of the average diameter.

Furthermore, in preferred embodiments no primary particles have an average diameter greater than

-38-

about 4 times the average diameter and preferably 3 times the average diameter, and more preferably 2 times the average diameter. In other words, the particle size distribution effectively does not have a tail indicative of a small number of particles with significantly larger sizes. This is a result of the small reaction region and corresponding rapid quench of the particles. An effective cut off in the tail of the size distribution indicates that there are less than about 1 particle in 10^6 have a diameter greater than a specified cut off value above the average diameter. Narrow size distributions, lack of a tail in the distributions and the roughly spherical morphology can be exploited in a variety of applications.

In addition, the nanoparticles generally have a very high purity level. The nanoparticles produced by the above described methods are expected to have a purity greater than the reactants because the laser pyrolysis reaction and, when applicable, the crystal formation process tends to exclude contaminants from the particle. Furthermore, crystalline nanoparticles produced by laser pyrolysis have a high degree of crystallinity. Similarly, the crystalline nanoparticles produced by heat processing have a high degree of crystallinity. Impurities on the surface of the particles may be removed by heating the particles to achieve not only high crystalline purity but high purity overall.

While the dispersions described herein can be applied in a variety of contexts, preferred applications include chemical-mechanical polishing of surfaces. Preferred materials for the performance of chemical mechanical polishing include, for example, manganese oxides, silicon oxides, aluminum oxides, silicon

-39-

carbides, titanium oxides, cerium oxides and silicon nitrides.

Aluminum oxide is known to exist in several crystalline phases including α - Al_2O_3 , δ - Al_2O_3 , γ - Al_2O_3 , ϵ -
5 Al_2O_3 , θ - Al_2O_3 , and η - Al_2O_3 . The delta phase has a tetragonal crystal structure, and the gamma phase has a cubic crystal structure. Although under certain conditions mixed phase materials are formed, laser
10 pyrolysis generally can be used effectively to produce single phase crystalline particles. The conditions of the laser pyrolysis can be varied to favor the formation of a single, selected phase of crystalline Al_2O_3 . Amorphous aluminum oxide can also be formed. Conditions favoring the formation of amorphous particles include,
15 for example, high pressures, high flow rates, high laser power and combinations thereof.

Manganese oxides are known to exist in a wide range of oxidation states from +2 to +4. The most common stoichiometries for manganese oxides include MnO ,
20 Mn_3O_4 , Mn_2O_3 , Mn_5O_8 , and MnO_2 . MnO and Mn_5O_8 have only a single known crystalline phase. In particular, MnO has a cubic crystal structure while Mn_5O_8 has a monoclinic crystal structure. Several of the manganese oxides can exist in alternative crystal structures. For example,
25 Mn_3O_4 has either a tetragonal or orthorhombic crystal structure. Mn_2O_3 has either a cubic or a hexagonal crystal structure. Also, MnO_2 has either a cubic, orthorhombic or tetragonal crystal structure.

Dispersions of various nanoscale particles
30 have uses in surface polishing as well as other applications. Several different types of nanoscale electroactive particles have been produced by laser pyrolysis with or without additional heat processing.

-40-

These particles generally have a very narrow particle size distribution, as described above.

In particular, nanoscale manganese oxide particles have been formed. The production of these particles is described in copending and commonly assigned U.S. Patent Application Serial No. 09/188,770 to Kumar et al., entitled "Metal Oxide Particles," incorporated herein by reference. This application describes the production of MnO, Mn₂O₃, Mn₃O₄ and Mn₅O₈.

The production of silicon oxide nanoparticles is described in copending and commonly assigned U.S. Patent Application Serial Number 09/085,514 to Kumar et al., entitled "Silicon Oxide Particles," incorporated herein by reference. This patent application describes the production of amorphous SiO₂. The production of titanium oxide nanoparticles and crystalline silicon dioxide nanoparticles is described in copending and commonly assigned, U.S. Patent Application Serial Number 09/123,255 to Bi et al., entitled "Metal (Silicon) Oxide/Carbon Composites," incorporated herein by reference. In particular, this application describes the production of anatase and rutile TiO₂. The production of aluminum oxide nanoparticles is described in copending and commonly assigned, U.S. Patent Application Serial Number 09/136,483 to Kumar et al., entitled "Aluminum Oxide Particles," incorporated herein by reference. In particular, this application disclosed the production of γ -Al₂O₃.

In addition, tin oxide nanoparticles have been produced by laser pyrolysis, as described in copending and commonly assigned U.S. Patent Application Serial No. 09/042,227 to Kumar et al., entitled "Tin Oxide Particles," incorporated herein by reference. The production of zinc oxide nanoparticles is described in

-41-

5 copending and commonly assigned U.S. Patent Application Serial Number 09/266,202 to Reitz, entitled "Zinc Oxide Particles," incorporated herein by reference. In particular, the production of ZnO nanoparticles is described.

10 The production of iron, iron oxide and iron carbide is described in a publication by Bi et al., entitled "Nanocrystalline α -Fe, Fe₃C, and Fe₇C₃ produced by CO₂ laser pyrolysis," J. Mater. Res. Vol. 8, No. 7 1666-1674 (July 1993), incorporated herein by reference. The production of nanoparticles of silver metal is described in copending and commonly assigned U.S. Patent Application Serial Number 09/311,506 to Reitz et al.,

15 entitled "Metal Vanadium Oxide Particles," incorporated herein by reference. Nanoscale carbon particles produced by laser pyrolysis is described in a reference by Bi et al., entitled "Nanoscale carbon blacks produced by CO₂ laser pyrolysis," J. Mater. Res. Vol. 10, No. 11, 2875-2884 (Nov. 1995), incorporated herein by reference.

20 The production of iron sulfide (Fe_{1-x}S) nanoparticles by laser pyrolysis is described in Bi et al., Material Research Society Symposium Proceedings, vol 286, p. 161-166 (1993), incorporated herein by reference. Precursors for laser pyrolysis production of

25 iron sulfide were iron pentacarbonyl (Fe(CO)₅) and hydrogen sulfide (H₂S).

30 Cerium oxide can be produced using the laser pyrolysis apparatuses described above. Suitable precursors for aerosol delivery include, for example, cerous nitrate (Ce(NO₃)₃), cerous chloride (CeCl₃) and cerous oxalate (Ce₂(C₂O₄)₃). Similarly, zirconium oxide can be produced using the laser pyrolysis apparatuses described above. Suitable zirconium precursors for

-42-

aerosol delivery include, for example, zirconyl chloride ($ZrOCl_2$) and zirconyl nitrate ($ZrO(NO_3)_2$).

The production of ternary nanoparticles of aluminum silicate and aluminum titanate can be performed by laser pyrolysis following procedures similar to the production of silver vanadium oxide nanoparticles described in copending and commonly assigned U.S. Patent Application Serial Number 09/311,506 to Reitz et al., entitled "Metal Vanadium Oxide Particles," incorporated herein by reference. Suitable precursors for the production of aluminum silicate include, for vapor delivery, a mixture of aluminum chloride ($AlCl_3$) and silicon tetrachloride ($SiCl_4$) and, for aerosol delivery, a mixture of tetra(N-butoxy) silane and aluminum isopropoxide ($Al(OCH(CH_3)_2)_3$). Similarly, suitable precursors for the production of aluminum titanate include, for aerosol delivery, a mixture of aluminum nitrate ($Al(NO_3)_3$) and titanium dioxide (TiO_2) powder dissolved in sulfuric acid or a mixture of aluminum isopropoxide and titanium isopropoxide ($Ti(OCH(CH_3)_2)_4$).

The synthesis by laser pyrolysis of silicon carbide and silicon nitride is described in the examples below.

D. Dispersions

For a variety of applications, a collection of nanoparticles must be dispersed for use. Formation of a dispersion provides for the direct use of the particle dispersion, for example, in the formation of a chemical-mechanical polishing composition, as described below. Alternatively, the particle dispersion can be an intermediate that provides a mechanism for the formation of small secondary particles that can be subsequently formed into a coating or the like. Once the dispersion is applied to the substrate surface, the liquid can be

-43-

removed to leave behind a deposit of small secondary particles at a desired location.

For some processing approaches, nanoscale powders can be kneaded with a liquid at very high particle concentrations. In contrast, the dispersions described herein refer to dispersions having particle concentrations of no more than about 50 weight percent. For the formation of a particle dispersion, the particular particle concentration depends on the selected application. At concentrations greater than about 50 weight percent, different factors can be significant with respect to the formation and characterization of the resulting viscous blend relative to parameters that characterize the more dilute particle dispersions.

Mechanical and/or physical forces can be used to separate the primary particles, which are held together by van der Waals forces and other short range electromagnetic forces between adjacent particles. Mechanical forces can be applied to the powders prior to dispersion in a solvent. Alternatively, mechanical forces can be applied as mixing, agitation and/or sonication following the combination of the powder or powders and a liquid. The liquid may apply physical forces in the form of solvation type interactions to the particles that may assist in the dispersion of the particles. Solvation type interactions can be energetic and/or entropic in nature. Additional compositions, such as surfactants, can be added to the liquid to assist with the dispersion for the particles. Suitable surfactants include, for example, octoxynol (sold as Triton® X), nonxynol (sold as Doxfax® 9N and Triton® N), and dodecyltrimethyl ammonium bromide (C12 TAB, $\text{CH}_3(\text{CH}_2)_{11}\text{N}(\text{CH}_3)_3$). For particular particles, the

-44-

properties of the dispersion can be adjusted by varying the pH and/or the ionic strength. Ionic strength can be varied by addition of inert salts, such as sodium chloride, potassium chloride or the like.

5 The secondary particle size refers to the size of the resulting particle agglomerates following dispersion of the powders in the liquid. Smaller secondary particles sizes are obtained if there is more disruption of the agglomerating forces between the
10 primary particles. Secondary particles sizes within a liquid dispersion can be measured by established approaches, such as dynamic light scattering. Suitable particle size analyzers include, for example, a Microtrac UPA instrument from Honeywell based on dynamic
15 light scattering and ZetaSizer Series of instruments from Malvern based on Photon Correlation Spectroscopy. The principles of dynamic light scattering for particle size measurements in liquids are well established.

 The presence of small secondary particle sizes
20 can result in significant advantages in the application of the dispersions. For example, in chemical mechanical polishing the secondary particle size may influence the polishing rate and the ultimate surface smoothness achieved, although primary particle size may continue to
25 play a significant role in polishing characteristics. In the formation of coatings, thinner and smoother coatings can be formed with a dispersion having smaller secondary particles. In preferred embodiments, the average secondary particle diameter is less than about
30 1000 nm, preferably less than about 500 nm, more preferably from about 10 nm to about 300 nm, even more preferably from about 10 nm to about 200 nm and even more preferably from about 10 nm to about 100 nm.

-45-

Once the dispersion is formed, the dispersion may eventually separate such that the particles collect on the bottom of the container without continued mechanical stirring or agitation. Different dispersions have different degrees of stability. The stability of a dispersion depends on the properties of the powders, the liquid, the processing used to form the dispersion and the presence of stabilizing agents. Suitable stabilizing agents include, for example, surfactants. Preferably, dispersions are reasonably stable, such that the dispersions can be used without significant separation during the subsequent processing steps. The required stability of a dispersion depends on the particular application.

15 Chemical-Mechanical Polishing

A variety of polishing compositions can advantageously incorporate elemental metal, metal/silicon oxide, metal/silicon carbide, metal/silicon nitride and/or metal/silicon sulfide particles, including compositions for performing chemical-mechanical polishing. The nanoparticles can function as abrasive particles and may also impart chemical polishing effects on the substrate surface. The narrow particle size distribution of the primary particles provides for improved polishing results. In particular, smoother polished surfaces with less scratches can result from the use of particles with a narrow particle size distribution.

The polishing composition can just comprise the abrasive nanoparticles produced using laser pyrolysis with or without a heat treatment, as described above. Preferably, the polishing composition is formed by dispersing the abrasive nanoparticles in an aqueous or nonaqueous solution. The dispersion/slurry generally

-46-

includes a liquid such as water, alcohol, acetone or the like. The liquid can comprise a liquid solution, such as a solution including water and an organic liquid. A surfactant can be added to the dispersion to assist with primary particle separation. The selected composition of the slurry generally depends on the composition of the substrate being processed, as described further below.

The polishing composition generally includes from about 0.05 percent to about 50 percent, preferably from about 0.5 percent to about 30 percent, and more preferably from about 0.5 percent to about 10 percent by weight nanoparticles. The uniform nanoparticles described herein can be used effectively to obtain high polishing rates at lower particle concentration. Using a lower concentration of abrasive particles is desirable due to reduced cost and a decreased amount of polishing composition to clean from the polished surface.

Suitable abrasive particles include, for example, elemental metal, metal/silicon oxides, metal/silicon carbides, metal/silicon nitrides and metal/silicon sulfides with average diameters less than about 100 nm and more preferably from about 5 nm to about 50 nm. In particular, preferred abrasive particles include compounds such as Fe, Ag, SiO₂, SiC, SiN, ZnO, SnO₂, CeO₂, ZrO₂, MnO, Mn₂O₃, Mn₃O₄, MnO₂, Al₂O₃, TiO₂, Fe₂O₃, Fe₃O₄, Fe₃C, Fe₇C₃, MoS₂, MoO₂, WC, WO₃ and WS₂. Suitable abrasive particles are described further, for example, in copending and commonly assigned U.S. patent application serial No. 08/961,735, entitled "Abrasive Particles for Surface Polishing," incorporated herein by reference, and in U.S. Patent 5,228,886 to Zipperian, "Mechanochemical Polishing Abrasive," incorporated herein by reference. Also, preferred

-47-

abrasive particles have a narrow diameter distribution and an effective cut off of particle diameters.

The polishing compositions can include other components to assist with the polishing process. For example, the polishing composition can include a mixture of abrasive particles. When using an additional abrasive particles, the polishing composition preferably includes from about 0.05 to about 10 percent additional abrasive particles. The polishing composition can be acidic or basic to improve the stability of the slurry and to improve the polishing characteristics. For polishing metals an acidic pH generally is preferred, for example, in the range from about 3.0 to about 4.0. A variety of acids can be used such as glacial acetic acid. For polishing oxide surfaces a basic polishing composition can be used, for example, with a pH from about 9.0 to about 11. To form a basic polishing composition, KOH or other bases can be added. Also, an oxidizing agent, such as H₂O₂, potassium ferricyanide, potassium iodate and ferric nitrate, can be added, especially for polishing metals.

Preferred polishing compositions have both a chemical and mechanical effect on a substrate. Thus, they are useful in chemical-mechanical polishing (CMP). In particular, for the polishing of semiconducting materials, oxides of semiconductor materials, or ceramic substrates for the production of integrated circuits, colloidal silica, formed by solution chemistry approaches, can have both a chemical and/or a mechanical effect on relevant substrates. Thus, some preferred embodiments of chemical mechanical polishes include in a solution both abrasive particles, such as aluminum oxide nanoparticles, and colloidal silica.

-48-

The formation of colloidal silica involves formation of an aqueous solution of hydrated silicon oxides. A colloidal silica solution preferably includes from about 0.05 percent to about 50 percent, and preferably from about 1.0 percent to about 20 percent by weight silica. The use of colloidal silica for polishing hard substrates is described in U.S. Patent No. 5,228,886 to Zipperian, "Mechanochemical Polishing Abrasive," incorporated herein by reference, and in U.S. Patent No. 4,011,099 to Gutsche, entitled "Preparation of Damage-Free Surface on Alpha-Alumina," incorporated herein by reference. Colloidal silica has been suggested to chemically react with certain surfaces, such as Al_2O_3 . Colloidal silica can be combined with nanoparticles produced by laser pyrolysis to form slurries for surface polishing. Alternatively, silica highly uniform in size can be produced by laser pyrolysis as a substitute for colloidal silica.

The solvents used in the formation of the polishing compositions preferably have a low level of contaminants. In particular, water used as a solvent should be deionized and/or distilled. The polishing composition preferably is free from any contaminants, i.e., any composition not included for effectuating the polishing process. In particular, the polishing composition preferably is free of soluble metal contaminants such as potassium and sodium salts. Preferably, the compositions contain less than about 0.01 percent and preferably less than about 0.001 percent, and more preferably less than about 0.0001 percent by weight soluble metal. Furthermore, the polishing composition preferably is free from particulate contaminants, which are not soluble in the solvent.

-49-

The polishing compositions can be used for mechanical or chemical-mechanical polishing that is performed manually or using a powered polishing machine. In either case, the polishing composition is generally applied to a polishing pad or cloth to perform the polishing. Any of a variety of mechanical polishers can be used, for example, vibratory polishers and rotary polishers.

The particular composition of abrasive particles should be selected such that the particles have an appropriate hardness for the surface to be polished as well as an appropriate distribution of diameters to obtain efficiently the desired smoothness. Aluminum oxide is very hard. Nevertheless, aluminum oxide nanoparticles are suitable for the polishing of hard and soft substrates. In particular, aluminum oxide particles are useful in slurries to polish metal materials including, for example, wires and films formed from copper (a relatively soft metal) and tungsten (a relatively hard metal). Acidic slurries are preferably used for polishing metal surfaces. Abrasive particles that are hard can result in undesired scratches in the surface of soft substrates, such as low dielectric materials, including, for example, polymeric materials. Preferred nanoparticles for polishing soft surfaces include, for example, SiO_2 , CeO_2 , TiO_2 , and ZrO_2 .

In many circumstances, it is desirable to have selectivity in the surface polishing. In particular, many devices, in particular microelectronic devices, include layers or partial layers of a plurality of different materials. For example, soft copper metal can be applied over buffer layers of tantalum, tantalum nitride, titanium nitride, or the like. Surface polishing of partially layered materials can be

-50-

performed in steps where each step is selective for a particular material. For example, a basic silicon oxide polishing composition can be used to polish a tantalum nitride layer while an acidic aluminum oxide composition
5 can be used to polish the copper material. Using selective polishing compositions, the properties of the resulting surfaces can be controlled more precisely. In preferred embodiments, selectivity leads to a removal rate of one surface composition that is at least about
10 5 times and preferably at least about 20 times the removal rate of another surface composition.

The polishing compositions are particularly useful for the polishing of surfaces for the production of integrated circuits. As the density of integrated
15 circuits on a single surface increases, the tolerances for smoothness of the corresponding substrates become more stringent. Presently, the patterning resolution of microelectronic devices and the like are about 0.13 microns. In the future this resolution is expected to
20 decrease. Therefore, it is important that polishing process is able to planarize surfaces and to remove topological structures, i.e. surface discontinuities. The polishing can be performed prior to applying circuit patterns onto the substrate and/or at intermediate
25 stages in the processing of the circuit board. Generally, both global planarity, i.e., extended flatness over the surface, and local smoothness, i.e., lack of relatively large topological structure, are significant issues that can be addressed by the
30 polishing approaches described herein.

The small size and uniformity of the abrasive particles disclosed herein are particularly suitable in polishing compositions for these applications. SiO₂ particles are suitable for the polishing of silicon

-51-

based semiconductor substrates. Similarly, layered structures involving patterned portions of insulating layers and conducting layers can be simultaneously planarized, as described in U.S. Patent No. 4,956,313 to Cote et al., entitled "Via-Filling and Planarization Technique," incorporated herein by reference. Magnetic storage disc, ceramic surfaces, optical lenses and other precision surfaces can be polished in an analogous fashion.

10 Continuous polishing results in the removal of a quantity of substrate material per unit of polishing time. The present nanoparticles can be used to remove greater than about 300 nm per minute from a hard metal surface, such as tungsten, and preferably greater than 15 about 500 nm per minute from a hard metal surface. Generally, the uniform nanoparticles described herein provide for faster surface polishing for a given concentration of polishing material. In preferred embodiments, abrasion with the preferred nanoparticles 20 described herein removes greater than about a factor of two and preferably a greater than a factor of three more material from the surface per unit time than corresponding polishing with particles having an equivalent composition and an average particle diameter of greater than about 1 micron. In other words, using 25 a polishing composition with an equivalent composition except that uniform nanoparticles described herein are substituted for other abrasive particles can lead to an improved polishing rate. The improved polishing rate 30 can be especially pronounced at particle concentrations less than about 12 weight percent and even more particularly at less than about 10 weight percent.

In addition, the uniform particles described herein can be used to obtain smoother polished surfaces

-52-

and with less scratches. In particular, metal surfaces can be generated with a root mean square surface roughness less than about 1 nm and more preferably less than about 0.75 nm.

5 The composition of the abrasive particles should also provide for removal of the polishing compositions after completion of the polishing. One approach to cleaning polished surfaces involves dissolving the abrasive particles with a cleaning
10 solution that does not damage the polished surface. The removal of an alumina based polishing compositions using a cleaning composition with phosphoric acid is described in U.S. Patent 5,389,194, entitled "Methods of Cleaning Semiconductor Substrates After Polishing," incorporated
15 herein by reference. This patent also contains a general description of polishing with slurries containing conventional aluminum oxides.

Coating Formation

20 The dispersions described above are particularly useful for the formation of coatings of nanoparticles. Due to the high uniformity of the nanoparticles, the resulting coatings can be made very thin and very smooth. In particular, an average thickness can average over discontinuities due to
25 particle structures. However, at a particular coverage over the surface, coatings formed with the nanoparticles described herein generally are smoother and more uniform due to the properties of the particles. Correspondingly, if larger, less uniform particles are
30 used to form a coating, the resulting coating generally will have greater structure and correspondingly less smoothness. These features of thickness and smoothness remain as coverage of a portion of the surface is reduced since larger particles need less surface

-53-

coverage to yield a smaller average thickness leading to more pronounced surface roughness.

The properties of the dispersion can be selected to yield corresponding coating properties. In particular, the concentration of the dispersion can be selected to balance factors such as a desired particle density within the coating and secondary particle size. Additional compositions for inclusion in the coating can be added to the dispersion. For example, a polymeric binder can be dissolved into the liquid.

The coating can be applied by any of a variety of approaches. Suitable coating approaches include, for example, spray coating, dip coating, spin coating, extrusion, and application with an ink jet nozzle. Following application of the coating the surface can be dried to remove any solvent present. In addition, the surface can be calendared to obtain desirable surface properties. Suitable coating approaches will depend on the properties of the dispersion, such as the viscosity, particle concentration and chemical properties, such as pH. Once the dispersion is coated onto a substrate the liquid generally is removed by evaporation with or without heating.

Coatings can be used effectively in the production of microelectronic devices. Due to the more uniform properties of the nanoparticles, smaller electronic structures, e.g., a resolution less than about 0.1 microns, can be produced. Suitable devices include field emission devices for displays using phosphor particles, such as ZnO_2 , barrier layers of silicon nitride particles under silicon dioxide or metal layers, metal particle, such as silver particles, for electrical interconnects, electrically insulating particles, such as silicon dioxide, for insulating

-54-

layers and hard coatings of silicon nitride and/or silicon carbide particles for the production of machine tools, such as tool-and-die components and any other cutting tools. Other devices include imaging devices, such as photocopiers, incorporating photocatalytic particles, such as titanium dioxide particles.

EXAMPLES

Example 1 - Formation of Silicon Nitride Nanoparticles by Laser Pyrolysis

Silicon nitride particles were produced by laser pyrolysis. The laser pyrolysis was performed in an apparatus essentially as shown in Figs. 7 with the batch collection apparatus replaced with a continuous collection apparatus as described in copending and commonly assigned U.S. Patent Application Serial No. 09/107,729 to Gardner et al., entitled "Particle Collection Apparatus And Associated Methods," incorporated herein by reference.

The reactant stream included ammonia (NH_3) and silane (SiH_4) that were delivered as vapor. The reaction conditions are summarized in Table 1.

TABLE 1

Phase	Silicon nitride (Si_3N_4)
Crystal Structure	amorphous
Pressure (Torr)	200

-55-

	Argon-Win (slm)	5
	Argon-Sld. (slm)	30
5	Ammonia (slm)	3.6-3.8
	Silane (slm)	2.0
	Production Rate (gm/hr)	280
10	Laser Power - Input (watts)	800-1000
	Laser Power - Output (watts)	400-500

slm = standard liters per minute

An x-ray diffractogram of the silicon nitride nanoparticles using the Cu(K α) radiation line on a Siemens D500 x-ray diffractometer are shown in Fig. 10. The diffractogram has peaks corresponding to crystalline silicon nitride as well as a broad peak at low scattering angles indicative of a larger degree of an amorphous state.

Transmission electron micrographs of the nanoparticles are shown in Fig. 11. An approximate size distribution was determined by manually measuring diameters of the particles shown in Fig. 11. The particle size distribution is shown in Fig. 12. An average particle size of about 17.6 nm was obtained. Only those particles showing clear particle boundaries were measured and recorded to avoid regions distorted in the micrograph. This should not bias the measurements obtained since the single view of the micrograph may not

-56-

show a clear view of all particles because of the orientation of the particles.

Example 2 - Formation of Silicon Carbide Nanoparticles by Laser Pyrolysis

5 Amorphous silicon carbide particles were produced by laser pyrolysis. The synthesis was laser pyrolysis apparatus essentially as shown in Fig. 1 with a single slit nozzle and the reactant delivery apparatus of Fig. 2.

10 The dimethyl diethoxysilane ($(\text{CH}_3\text{CH}_2\text{O})_2\text{Si}(\text{CH}_3)_2$) (Strem Chemical, Inc., Newburyport, MA) precursor vapor was carried into the reaction chamber by bubbling Ar gas through the dimethoxysilane liquid stored in a container at room temperature. Additional argon was added as a
15 diluent to the reactant stream. The dimehoxysilane decomposes to form the silicon carbide particles. The reactant gas mixture containing dimethoxysilane, Ar and C_2H_4 (optionally) was introduced into the reactant gas nozzle for injection into the reactant chamber. The
20 reactant gas nozzle had dimensions 5/8 in x 1/8 in. C_2H_4 gas was used, optionally, as a laser absorbing gas for some runs, although dimethoxysilane may absorb CO_2 laser radiation sufficiently that ethylene may not be necessary. Argon was used as an inert gas.

25 Representative reaction conditions for the production of amorphous silicon carbide nanoparticles are described in Table 2.

Table 2

Phase	Silicon carbide	Silicon carbide
Crystal Structure	Amorphous	Amorphous
Pressure (Torr)	410	700

	Argon-Win (slm)	2.24	2.24
	Argon-Sld. (slm)	8.40	8.40
5	Ethylene (slm)	1.61	0.00
	Carrier Gas - Argon (slm)	1.13	1.97
	Dilution Gas - Argon (slm)	1.4	0.0
10	Precursor Temp. (°C)	Room Temp.	Room Temp.
	Production Rate (gm/hr)	3.0	3.28
15	Laser Power - Input (watts)	970	1140
	Laser Power - Output (watts)	700	1020

slm = standard liters per minute

Argon - Win. = argon flow through inlets 216, 218

20 Argon - Sld. = argon flow through annular channel 142

An x-ray diffractogram of product nanoparticles produced under the conditions of column 2 of Table 1 is shown in Fig. 13. Broad diffraction peaks at low scattering angles are seen corresponding to
25 amorphous structure.

The transmission electron micrograph for the materials used to produce the x-ray diffractogram in Fig. 13 is shown in Fig. 14. An approximate size distribution was determined by manually measuring
30 diameters of the particles shown in Fig. 13. The particle size distribution is shown in Fig. 15. An average particle size of about 19.5 nm was obtained. Only those particles showing clear particle boundaries were measured and recorded to avoid regions distorted in
35 the micrograph. This should not bias the measurements

-58-

obtained since the single view of the micrograph may not show a clear view of all particles because of the orientation of the crystals.

Example 3 - Secondary Particle Sizes

5 This example provides a description of the formation of well dispersed dilute solutions of nanoparticles with several varieties of metal oxide, silicon oxide, silicon carbide and silicon nitride nanoparticles produced by laser pyrolysis.

10 The metal oxide nanoparticles were produced by laser pyrolysis as described in referenced patent applications listed above. In particular, nanoparticles of aluminum oxide, manganese oxide (MnO), titanium oxide and zinc oxide were used. Similarly, the silicon oxide
15 nanoparticles were produced as described in the patent application referenced above. The aluminum oxide, manganese oxide, titanium oxide and silicon oxide particles had average diameters from about 15 nm to about 20 nm. The manganese oxide and zinc oxide
20 nanoparticles had average diameters from about 25 nm to about 40 nm. The silicon nitride and silicon carbide were produced according to the description in Examples 1 and 2, respectively.

 To perform the secondary particle size
25 measurements, the particles were dispersed in deionized water at a concentration of about 0.02 weight percent. The secondary particles size, i.e., the particle size of the powders dispersed in the water, was measured with a Brookhaven 90Plus Particle Size Analyzer (Brookhaven
30 Instruments Ltd., England) that operates by dynamic light scattering for particle sizes down to 2 nm. The results are presented in Table 3.

TABLE 3

Compound	Secondary Particle Size (nm)	Surfactant*	pH
aluminum oxide	98	no	3.0
manganese oxide	155	yes	6.6
silicon oxide	232	yes	5.0
silicon carbide	163	yes	6.0
silicon nitride	204	yes	3.0
titanium oxide	230	yes	7.0
zinc oxide	221	yes	7.0

10 * Surfactant = Triton® X

Thus, well dispersed secondary particles were produced with all of the nanoparticles produced by laser pyrolysis.

15 Example 4 - Surface Polishing with Alumina Nanoparticles

This example demonstrates the polishing of the surface of a tungsten wafer with alumina slurries.

Aluminum oxide nanoparticles were produced as described in copending and commonly assigned U.S. Patent Application Serial No. 09/136,483 to Kumar et al. (the
 20 Kumar '483 application), entitled "Aluminum Oxide Particles," incorporated herein by reference. In particular, the aluminum oxide nanoparticles had an average diameter of 7 nm, a very narrow particles size distribution and a γ -Al₂O₃ (cubic) crystal structure.
 25 The particles were produced by laser pyrolysis with subsequent heat treatment under the conditions described in the Example of the Kumar '483 application.

To form the slurry, 15.0 g of aluminum oxide nanoparticles were added to 285 g of deionized water

-60-

with constant stirring. The pH was then adjusted to 4 with the addition of nitric acid. The resulting aluminum oxide slurry was sonicated for 5 minutes to disperse the aluminum oxide powder. Subsequently, a
 5 9.87 g quantity of potassium ferricyanide ($K_3Fe(CN)_6$) was added to form a slurry for polishing.

Secondary particle size in the slurries was measured using several alternative approaches and corresponding equipment. A Brookhaven Zetaplus
 10 instrument (Brookhaven Instruments Ltd., England) and a Honeywell Microtrac UPA 150 instrument (Honeywell, Minneapolis, MN) were used to perform dynamic light scattering in dilute slurry solutions, about 0.05 wight percent. An CHDF200 acoustic attenuation spectroscopy-
 15 particle size instrument from Matec Applied Sciences, Northboro, MA was used to measure particle sizes in the undiluted slurry. The results are summarized in Table 4.

TABLE 4

Instrument	Average Particle Size
TEM - primary particle size	20 nm
Brookhaven Zeta Plus	97 nm
Microtrac UPA150	87 nm
25 Matec CHDF 2000	92 nm

The secondary particle size measurement (Matec CHDF 2000) in the more concentrated solution agreed with the more dilute measurements.

Tungsten metal wafers and silicon oxide wafers
 30 were polished with a Struers RotoPol 31 polisher (Struers Inc., Denmark) with a IC-1000/SUBA IV stacked

-61-

polishing pads from Rodel, Phoenix, AZ. Following typical chemical-mechanical polishing processes, the wafer is placed against a rotating polishing pad while polishing slurry is deposited between the pad and the
5 wafer. The wafer was attached to a shaft and lowered onto the pad, which was affixed to a rotating support. The pad was used to provide support against the sample surface.

The rate of removal of material from the wafer
10 was determined by measuring the difference in the initial and final thicknesses of the wafer. The thickness of the silicon oxide wafers was measured by ellipsometry using an Ellipsometer from J. A. Woollam CO., Inc., Lincoln, NE. The thickness of the tungsten
15 wafer was measured by sheet resistance using a four point probe produced in house. Surface roughness was determined by atomic force microscopy using a Nanoscope III instrument from Digital Instruments, Santa Barbara, CA. Three dimensional illustrations of the surface
20 roughness measurements are shown in the Figures with the unpolished surface shown in Fig. 16 and the polished surface shown in Fig. 17.

The embodiments described above are intended to be illustrative and not limiting. Additional
25 embodiments are within the claims below. Although the present invention has been described with reference to preferred embodiments, workers skilled in the art will recognize that changes may be made in form and detail without departing from the spirit and scope of the
30 invention.

-62-

WHAT IS CLAIMED IS:

1. A particle dispersion comprising a liquid and a collection of particles at a concentration of less than about 50 weight percent in the dispersion, the collection of particles having an average primary particle diameter less than about 100 nm and effectively no particles having a primary particle diameter greater than about three times the average primary particle diameter.
2. The particle dispersion of claim 1 having an average secondary particle size less than about 1000 nm.
3. The particle dispersion of claim 1 wherein the particles comprise a compound selected from the group consisting of silicon nitride, silicon carbide, Al_2O_3 , CeO_2 , TiO_2 , MnO , ZnO , MnO_2 , Mn_2O_3 , Mn_3O_4 , SnO_2 , Fe_2O_3 , ZrO_2 , SiO_2 , alumina silicate, alumina titanate, carbon, and mixtures thereof.
4. The particle dispersion of claim 1 wherein the particles comprises a metal oxide.
5. The particle dispersion of claim 1 wherein the solvent has a pH less than about 4 pH units.
6. The particle dispersion of claim 1 wherein the solvent has a pH less than about 3 pH units.
7. The particle dispersion of claim 1 wherein the solvent has a pH greater than about 9 pH units.
8. The particle dispersion of claim 1 wherein the solvent has a pH from about 9 pH units to about 11 pH units.
9. The particle dispersion of claim 1 wherein the solvent has a pH from about 6 pH units to about 8 pH units.
10. The particle dispersion of claim 1 further comprising a surfactant.

-63-

11. The particle dispersion of claim 10 wherein the surfactant is selected from the group consisting of octoxynol, nonxynol, and dodecyl trimethyl ammonium bromide.

12. The particle dispersion of claim 1 further comprising an oxidizing agent.

13. The particle dispersion of claim 12 wherein the oxidizing agent is selected from the group consisting of potassium ferricyanide, potassium iodate hydrogen peroxide, and ferric nitrate.

14. The particle dispersion of claim 1 wherein the liquid comprises water.

15. The particle dispersion of claim 1 wherein the liquid comprises an organic liquid.

16. The particle dispersion of claim 15 wherein the organic liquid is selected from the group consisting of alcohols, acetone, carboxylic acids.

17. The particle dispersion of claim 1 wherein the liquid comprises a solution of water and an organic solvent.

18. The particle dispersion of claim 1 wherein the average primary particle diameter is from about 5 nm to about 50 nm.

19. The particle dispersion of claim 1 wherein the concentration of the collection of particles is less than about 30 weight percent.

20. The particle dispersion of claim 1 wherein the concentration of the collection of particles is less than about 20 weight percent.

21. The particle dispersion of claim 1 wherein the concentration of the collection of particles is less than about 10 weight percent.

-64-

22. The particle dispersion of claim 1 wherein the concentration of the collection of particles is less than about 5 weight percent.

23. The particle dispersion of claim 1 wherein the collection of particles effectively having no particles with a primary particle diameter greater than about two times the average primary particle diameter.

24. The particle dispersion of claim 1 wherein the collection of particles have a distribution of diameters of the primary particles such that at least about 95 percent of the primary particles have a diameter greater than about 40 percent of the average diameter and less than about 160 percent of the average diameter.

25. The particle dispersion of claim 1 wherein the particles are produced by laser pyrolysis.

26. A method of polishing a surface comprising abrading the surface with a dispersion of claim 1.

27. The method of claim 26 wherein the surface comprises a plurality of compositions and wherein the dispersion has a selective removal with the removal rate of one surface composition being at least about 5 times greater than the removal rate of another surface composition.

28. A method for forming a particle dispersion, the method comprising mixing a collection of particles with a liquid, the collection of particles having an average primary particle diameter from about 5 nm to about 50 nm and effectively no particles having a primary particle diameter greater than about three times the average primary particle diameter.

29. A method for polishing a surface comprising a metal or metal compound, the method comprising abrading the surface with a particle dispersion having a concentration of particles less than about 5 weight

-65-

percent and the particle dispersion comprising a collection of particles having an average primary particle diameter less than about 100 nm.

30. The method of claim 29 wherein the particle dispersion has a concentration of particles less than about 3 weight percent.

31. A method for polishing a surface comprising metal or a metal compound, the method comprising abrading the surface with a particle dispersion, the particle dispersion comprising a collection of particles having an average primary particle diameter less than about 100 nm, the abrasion removing greater than about a factor of two more material from the surface per unit time than corresponding polishing with an equivalent concentration of particles having an equivalent composition and an average particle diameter of greater than about 1 micron.

32. A method for polishing a surface comprising a metal or a metal compound, the method comprising abrading the surface with a particle dispersion to produce a surface with a root mean square roughness of less than about 0.75 nm.

33. A device having a surface with a coating comprising a collection of particles having an average primary particle diameter less than about 100 nm and effectively no particles having a primary particle diameter greater than about three times the average primary particle diameter.

34. The device of claim 33 wherein the collection of particles have a distribution of sizes such that at least about 95 percent of the primary particles have a diameter greater than about 40 percent of the average diameter and less than about 160 percent of the average diameter.

-66-

35. The device of claim 34 wherein the device comprises a field emission device and the collection of particle comprise phosphor particles.

36. The device of claim 34 wherein the device comprises a microelectronic integrated circuit and the collection of particles form a barrier layer, electrical interconnect, or insulating layer within the integrated circuit.

37. The device of claim 34 wherein the device comprises an imaging device and the collection of particles comprise photocatalytic particles.

38. The device of claim 34 wherein the device comprises a machine tool with a hard surface coating comprising the collection of particles.

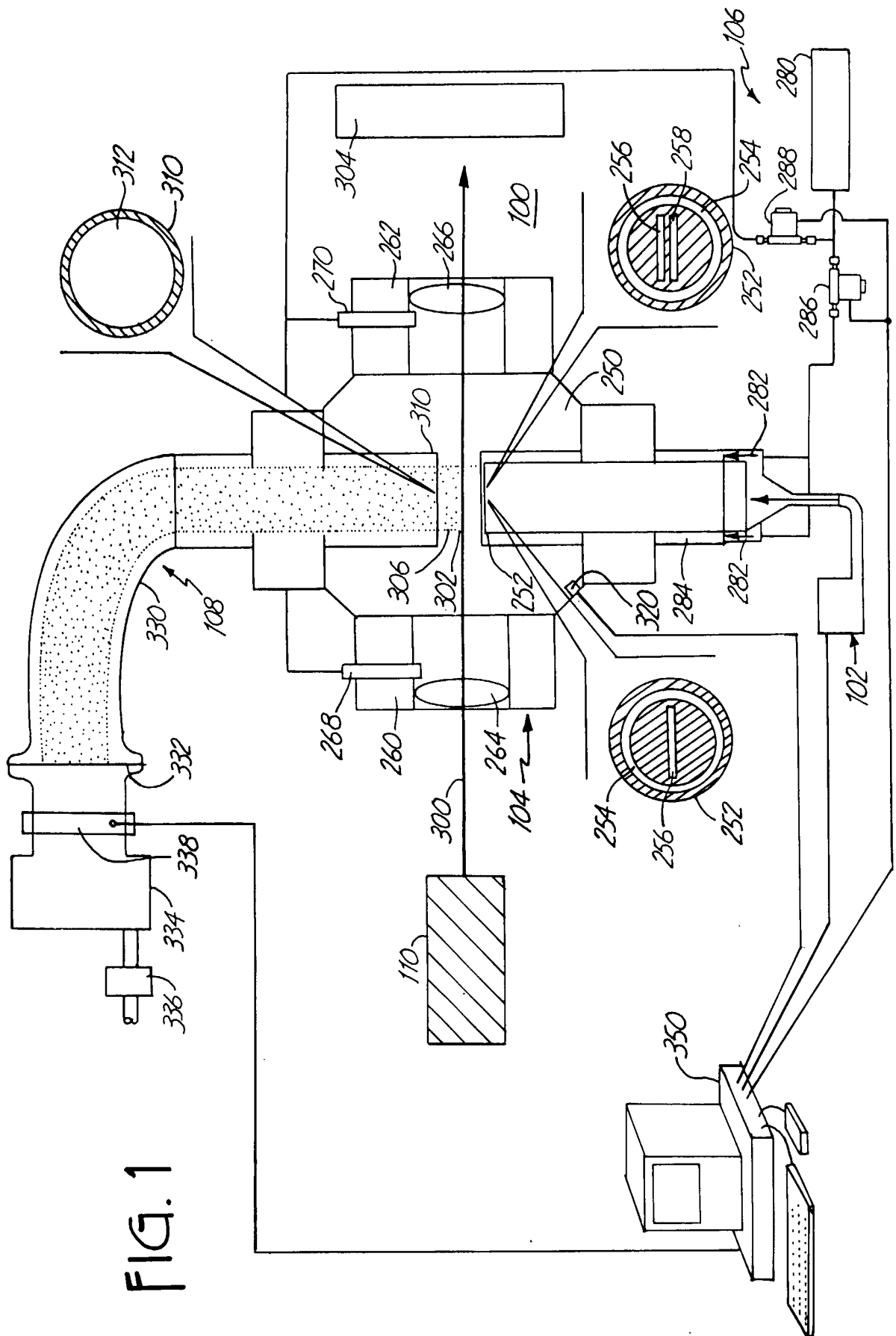

FIG. 1

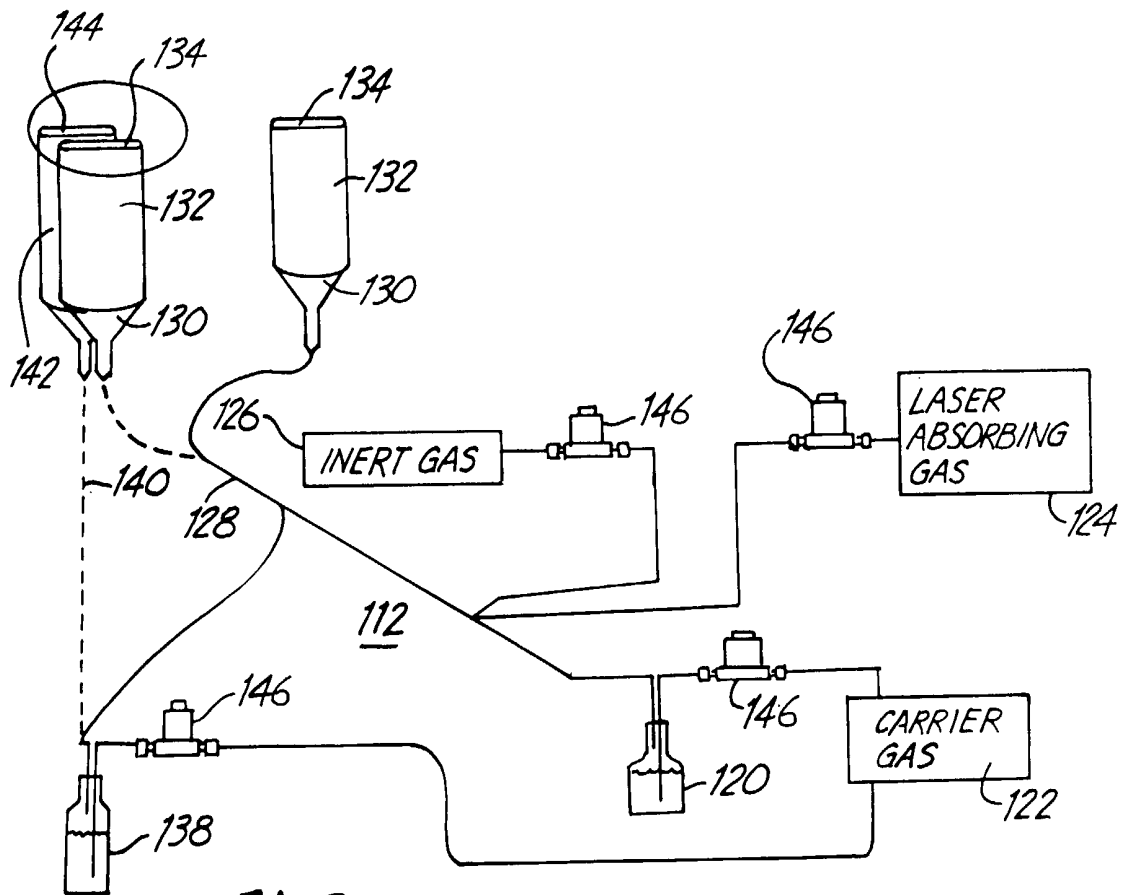

FIG. 2

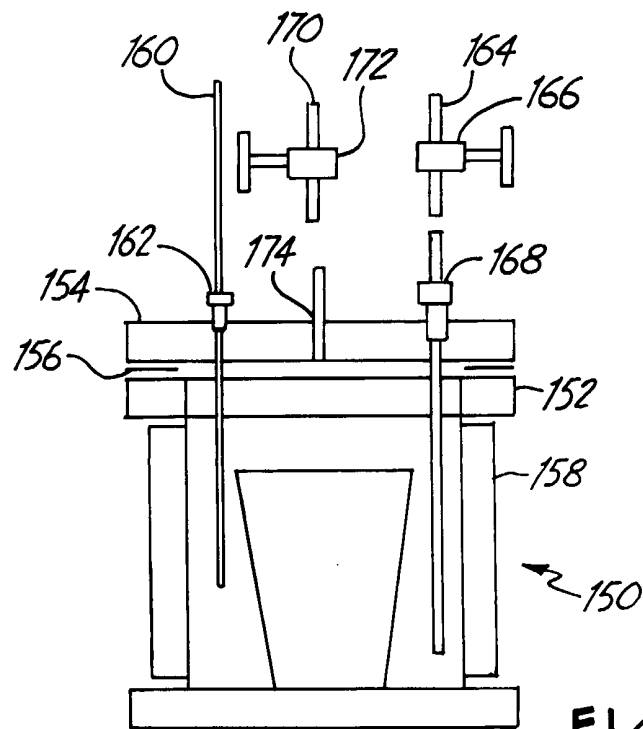

FIG. 3

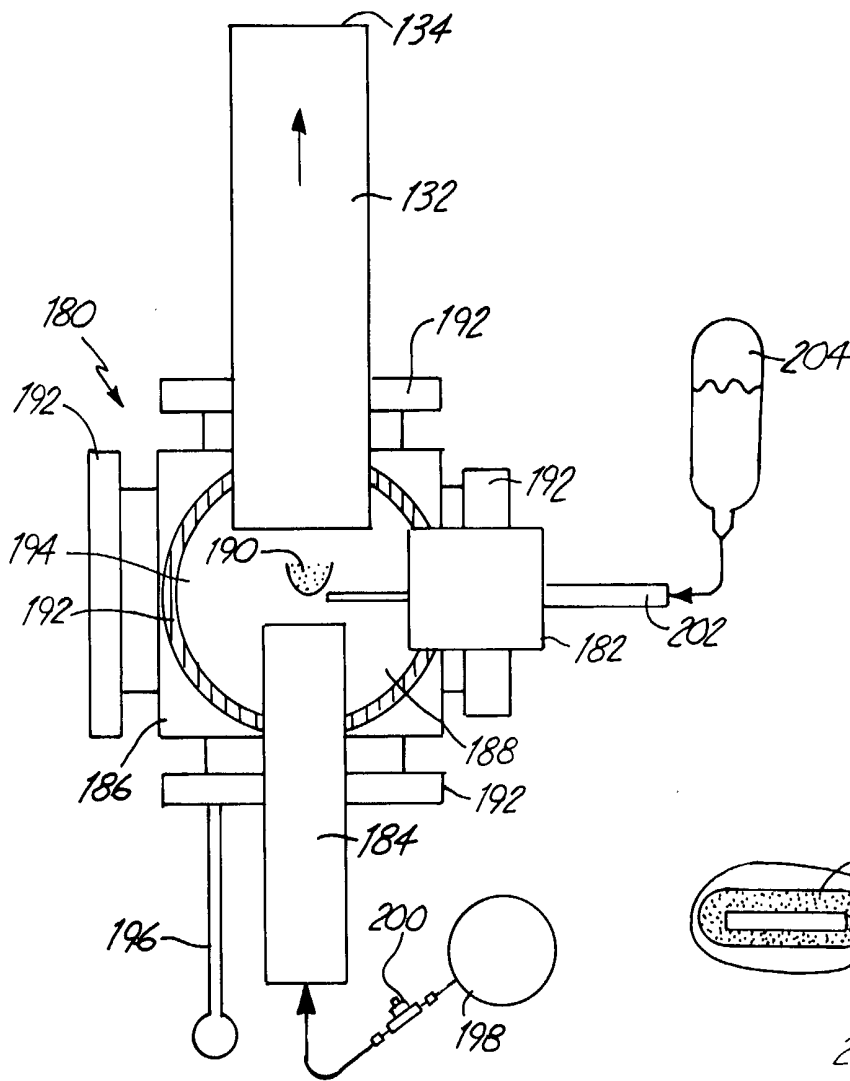

FIG. 4

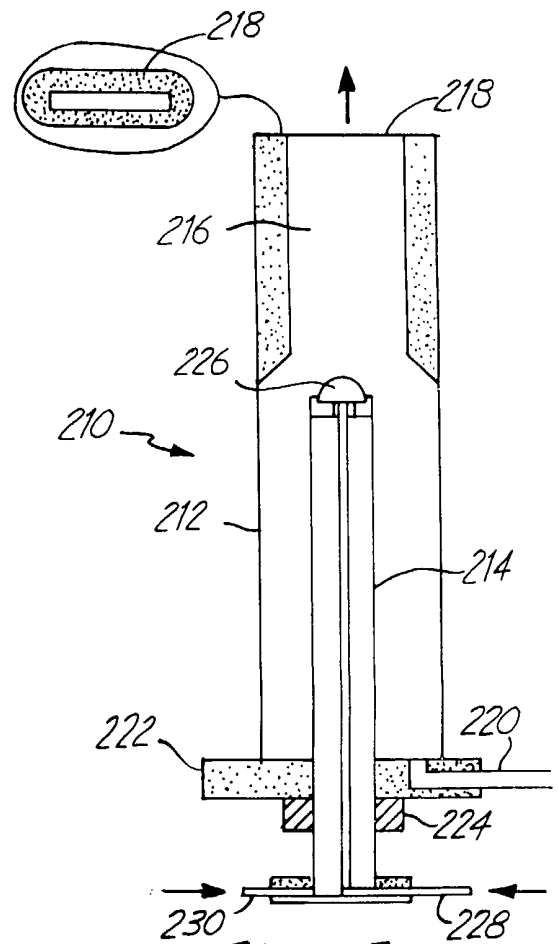
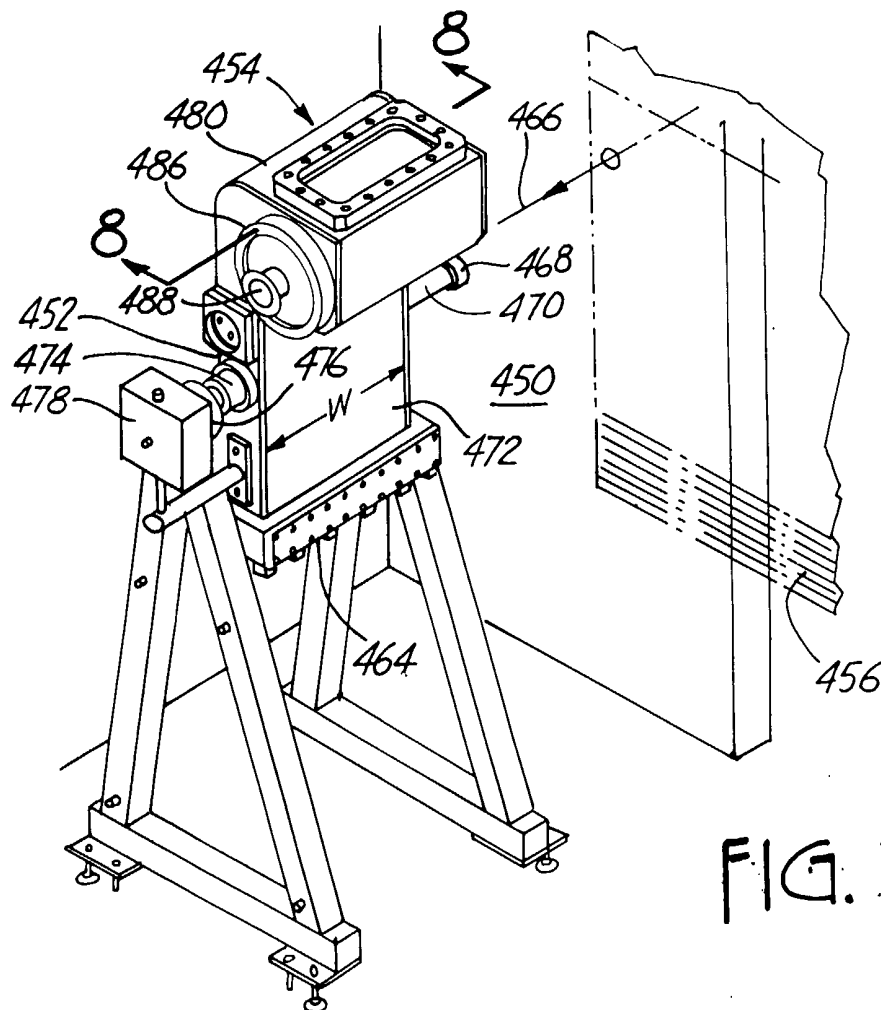
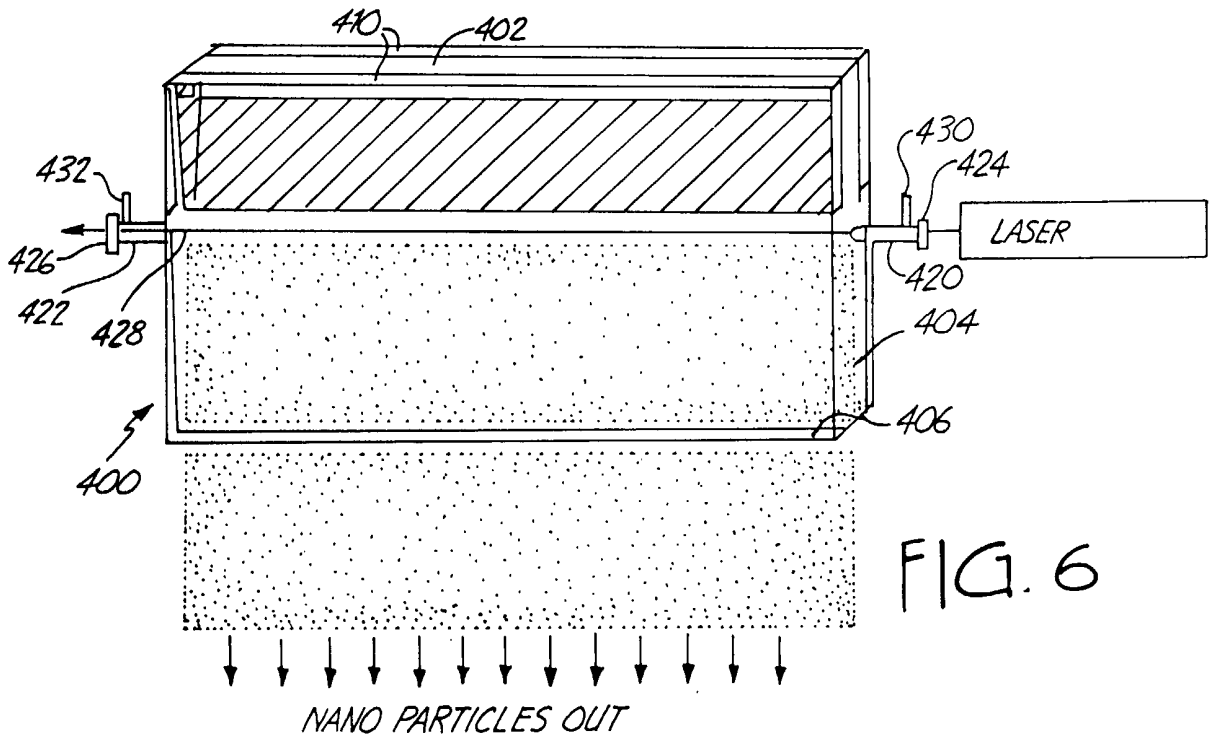
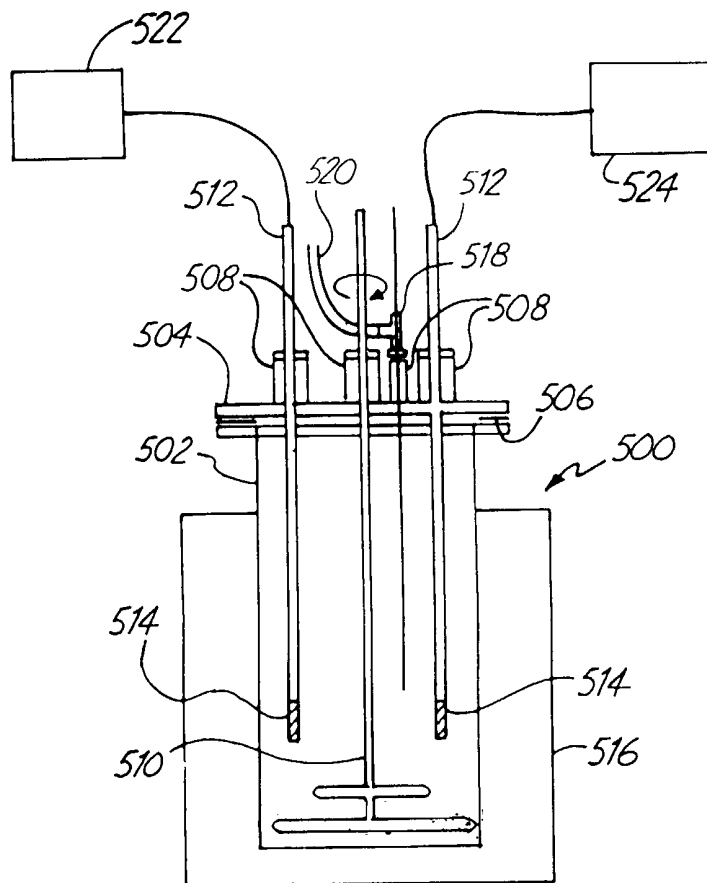
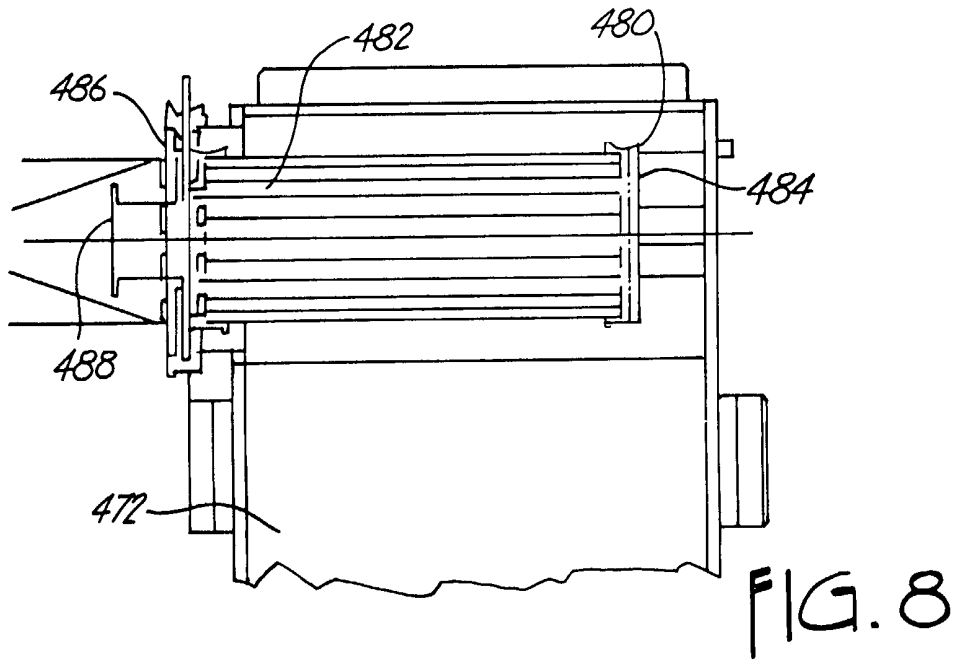

FIG. 5





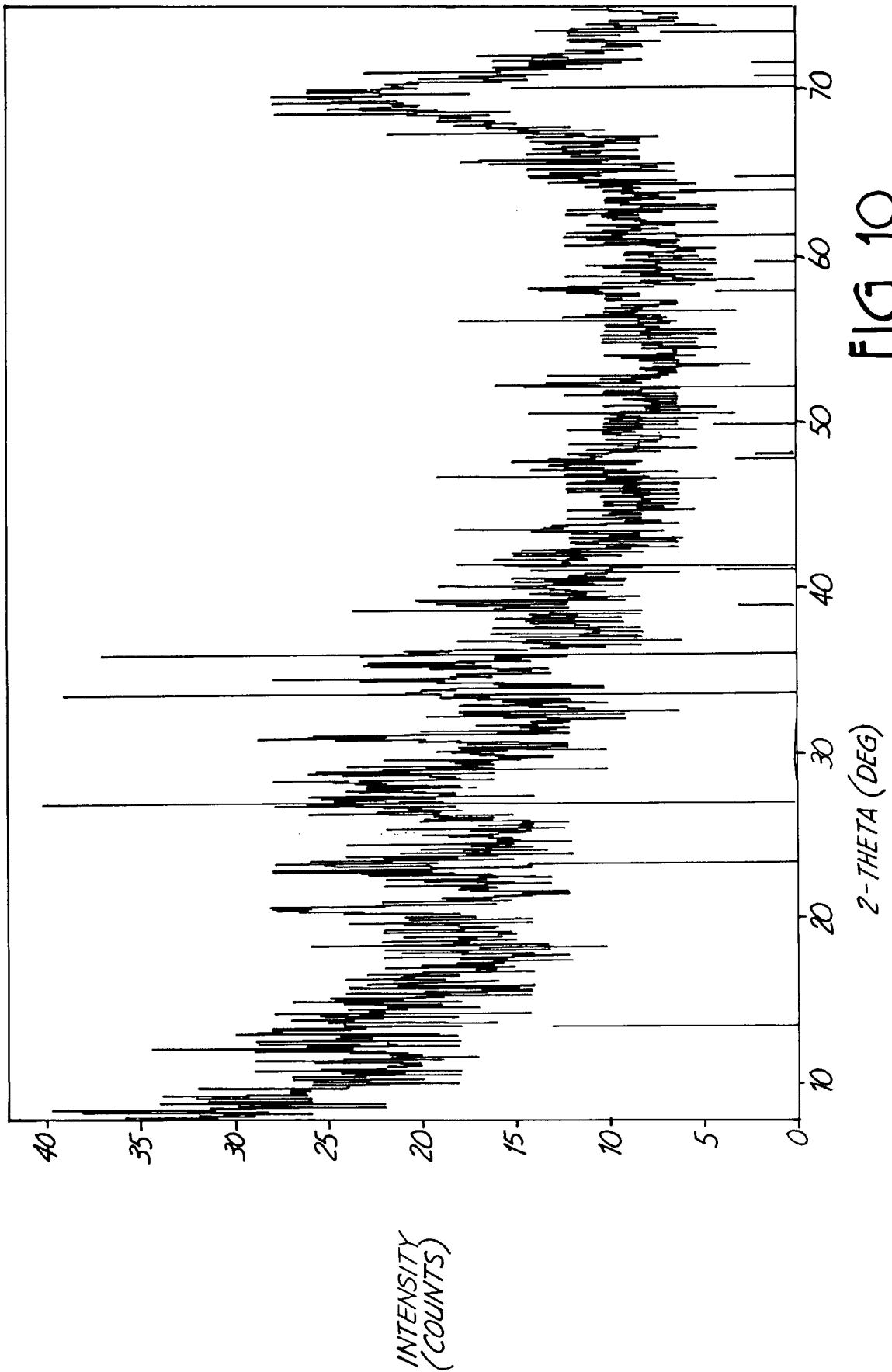
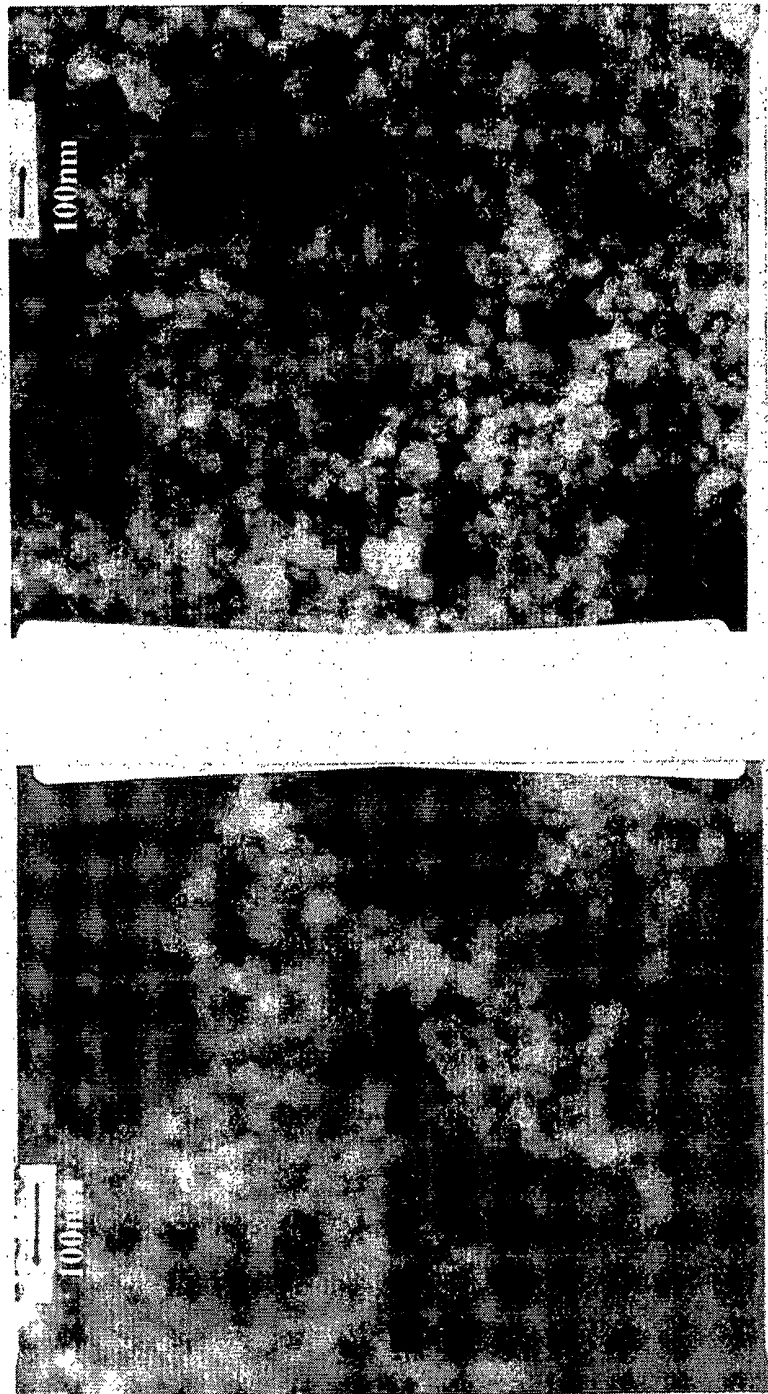

FIG. 10

FIG. 11



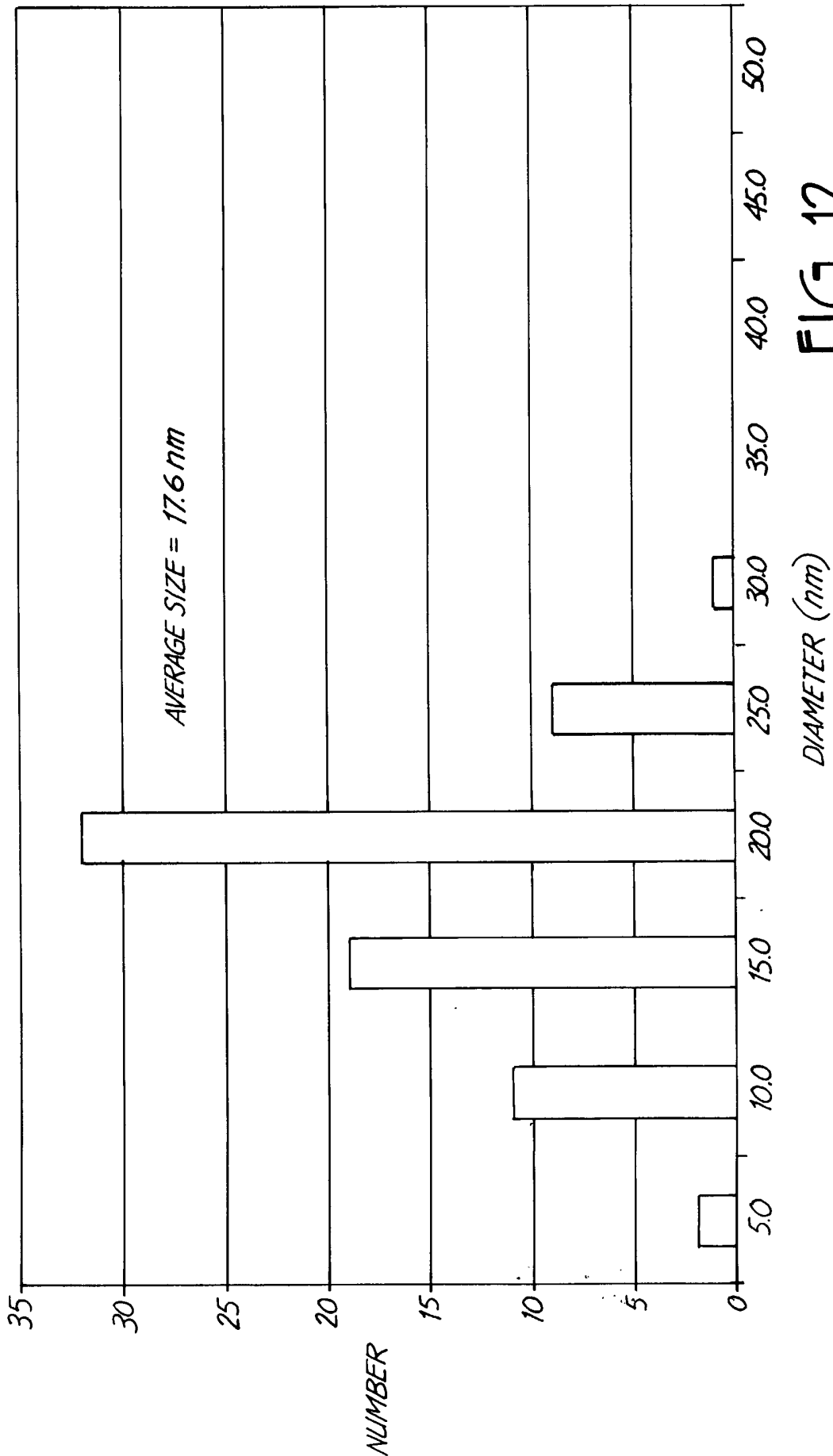

FIG. 12

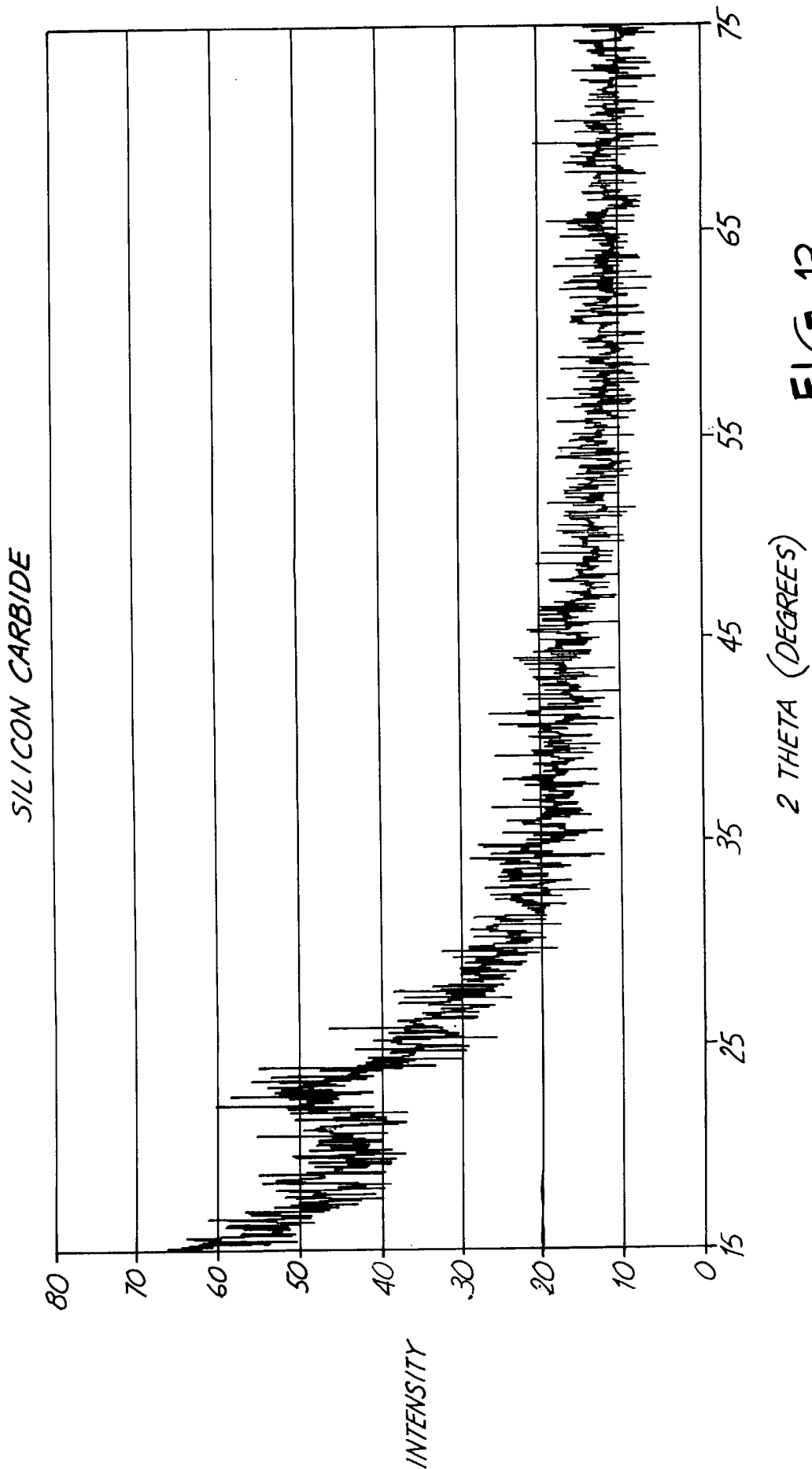

FIG. 13

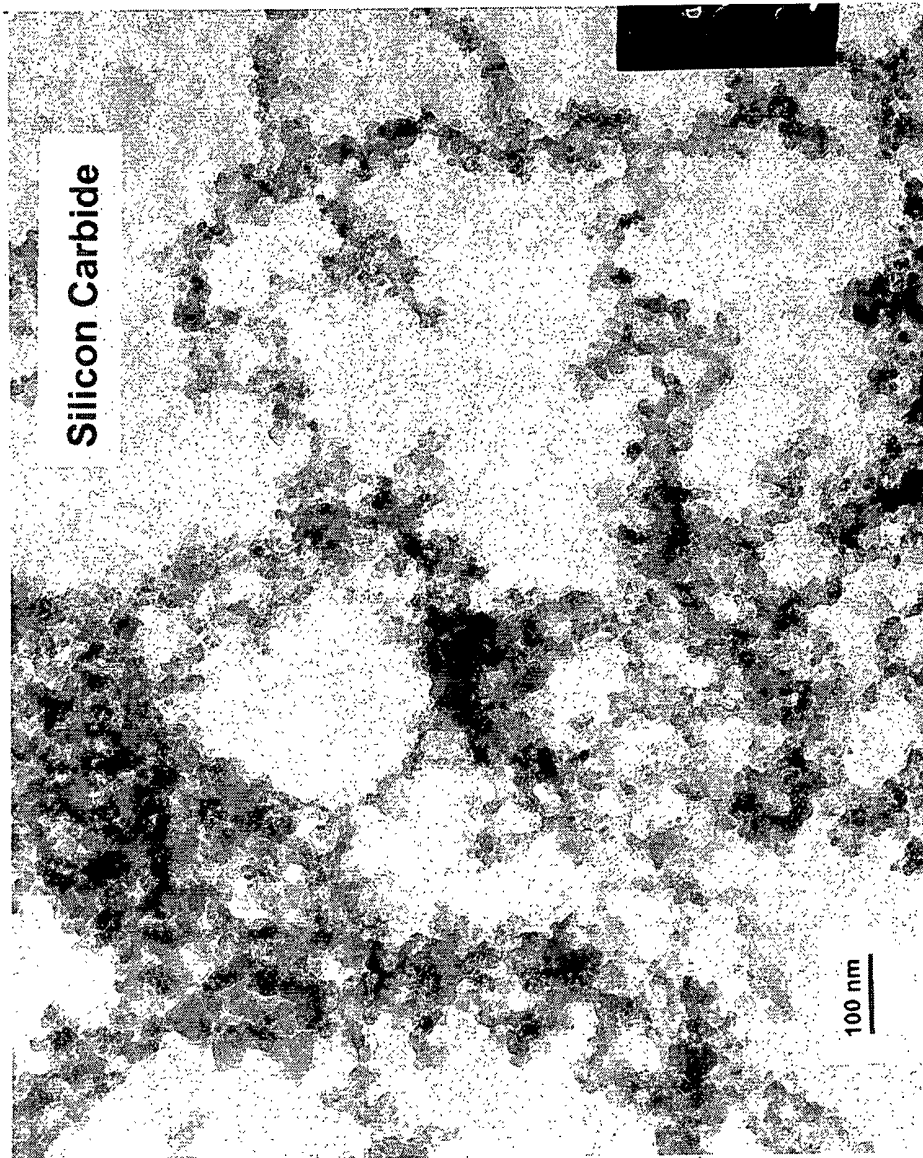
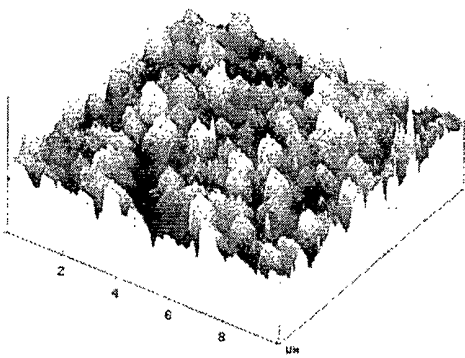
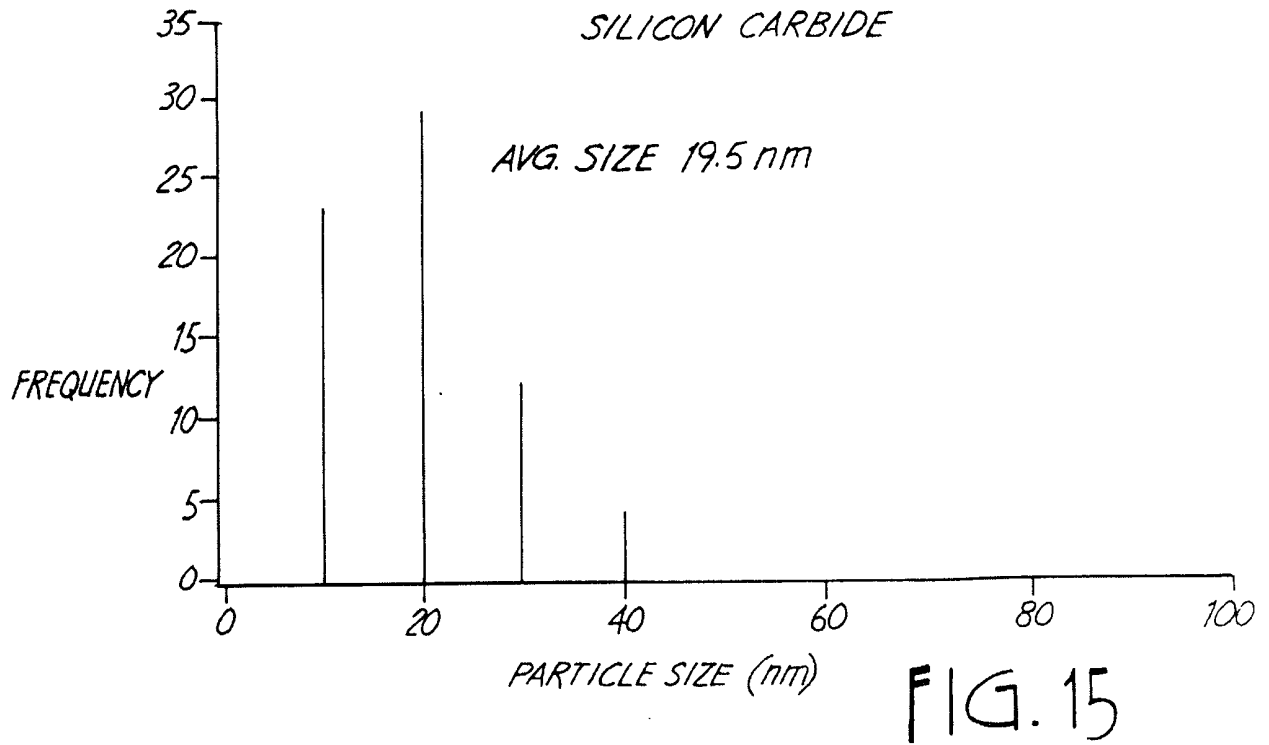
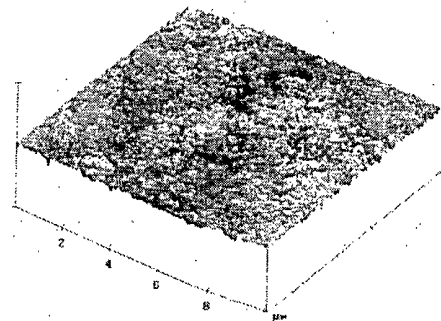

FIG. 14



RMS: 13.75 nm
R_{max}: 121.4 nm

FIG. 16



RMS: 0.46 nm
R_{max}: 5.76 nm

FIG. 17

INTERNATIONAL SEARCH REPORT

International application No.
PCT/US00/30288

A. CLASSIFICATION OF SUBJECT MATTER		
IPC(7) : Please See Extra Sheet. US CL : Please See Extra Sheet. According to International Patent Classification (IPC) or to both national classification and IPC		
B. FIELDS SEARCHED		
Minimum documentation searched (classification system followed by classification symbols) U.S. : Please See Extra Sheet.		
Documentation searched other than minimum documentation to the extent that such documents are included in the fields searched NONE		
Electronic data base consulted during the international search (name of data base and, where practicable, search terms used) NONE		
C. DOCUMENTS CONSIDERED TO BE RELEVANT		
Category*	Citation of document, with indication, where appropriate, of the relevant passages	Relevant to claim No.
Y	US 5,389,194 A (ROSTOKER ET AL.) 14 February 1995 (14/02/95), see entire document.	1-32
Y	US 5,861,054 A (MIYASHITA ET AL.) 19 January 1999 (19/01/99), see entire document.	1-32
Y	US 5,935,278 A (ISHITOBII ET AL.) 10 August 1999 (10/08/99), see claims 6-7.	12,13
Y	US 5,700,551 A (KUKINO ET AL.) 23 December 1997 (23/12/97), see the claims.	33,34,38
Y	US 5,930,608 A (YAMAZAKI ET AL.) 27 July 1999 (27/07/99), see column 5, lines 10-30.	33,34,36
Y	WO 97/10186 A1 (SAINT-GOBAIN) 20 March 1997 (20/03/97), see the abstract and the claims.	33,34,37
<input checked="" type="checkbox"/> Further documents are listed in the continuation of Box C. <input type="checkbox"/> See patent family annex.		
* Special categories of cited documents:	"T"	later document published after the international filing date or priority date and not in conflict with the application but cited to understand the principle or theory underlying the invention
"A" document defining the general state of the art which is not considered to be of particular relevance	"X"	document of particular relevance; the claimed invention cannot be considered novel or cannot be considered to involve an inventive step when the document is taken alone
"E" earlier document published on or after the international filing date	"Y"	document of particular relevance; the claimed invention cannot be considered to involve an inventive step when the document is combined with one or more other such documents, such combination being obvious to a person skilled in the art
"L" document which may throw doubts on priority claim(s) or which is cited to establish the publication date of another citation or other special reason (as specified)	"&"	document member of the same patent family
"O" document referring to an oral disclosure, use, exhibition or other means		
"P" document published prior to the international filing date but later than the priority date claimed		
Date of the actual completion of the international search 15 DECEMBER 2000	Date of mailing of the international search report 31 JAN 2001	
Name and mailing address of the ISA/US Commissioner of Patents and Trademarks Box PCT Washington, D.C. 20231 Facsimile No. (703) 305-3230	Authorized officer <i>B. Marcheschi</i> MICHAEL MARCHESCHI Telephone No. (703) 308-0661	

INTERNATIONAL SEARCH REPORT

International application No.
PCT/US00/30288

C (Continuation). DOCUMENTS CONSIDERED TO BE RELEVANT

Category*	Citation of document, with indication, where appropriate, of the relevant passages	Relevant to claim No.
Y	US 5,955,250 A (CHRISTIAN ET AL.) 21 September 1999 (21/09/99), see column 7, line 17-column 8, line 11 and the claims.	33,34,37
Y, &	WO 99/23189 A1 (NANOGRAM CORPORATION) 14 May 1999 (14/05/99), see entire document.	1-32
Y	WO 98/37165 A1 (NANOCHEM RESEARCH, LLC) 27 August 1998 (27/08/98), see page 40 and the claims.	33,34,35
Y	WO 97/10186 A1 (SAINT-GOBAIN) 20 March 1997 (20/03/97), see the abstract and the claims.	33,34,37

INTERNATIONAL SEARCH REPORT

International application No.
PCT/US00/30288

A. CLASSIFICATION OF SUBJECT MATTER:

IPC (7):

C09K 3/14; C09G 1/02, 1/04; C03C 17/00, 8/20, 17/34; C09K 11/08, 11/78, 11/70; H01J 29/18; B32B 5/16; B24D 3/00; B23B 27/00; C23C 14/06; C01B 31/00, 33/14, 33/20; C01F 7/02, 17/00; C01G 9/02, 19/02, 23/047, 25/02, 45/02, 49/02

A. CLASSIFICATION OF SUBJECT MATTER:

US CL :

51/295, 307, 308, 309; 106/3; 428/212, 701; 313/472, 467, 485, 503; 252/301.4R, 301.4P; 438/692, 693; 423/263, 325, 345, 445R, 592, 599, 600, 605, 608, 610, 618, 625, 632, 622

B. FIELDS SEARCHED

Minimum documentation searched

Classification System: U.S.

51/295, 307, 308, 309; 106/3; 428/212, 701; 313/472, 467, 485, 503; 252/301.4R, 301.4P; 438/692, 693; 423/263, 325, 345, 445R, 592, 599, 600, 605, 608, 610, 618, 625, 632, 622