

C. W. SEYMOUR.  
 APPARATUS FOR CASTING METALS AND THE LIKE.  
 APPLICATION FILED OCT. 8, 1913.

Patented June 30, 1914.

1,101,816.

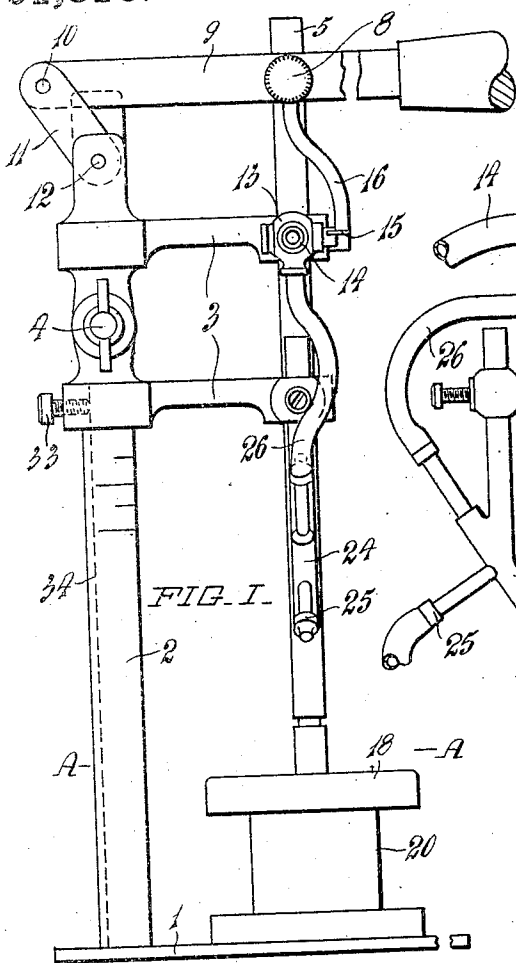

FIG. 1.

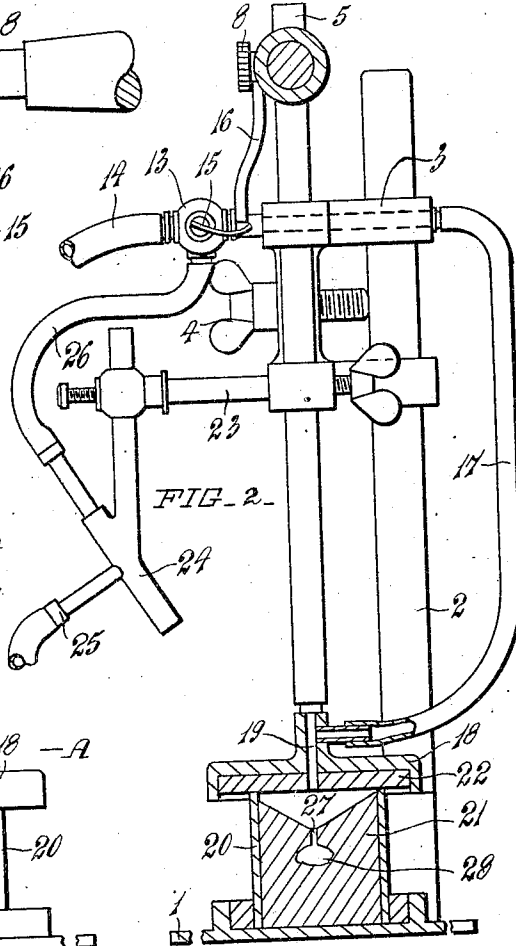

FIG. 2.

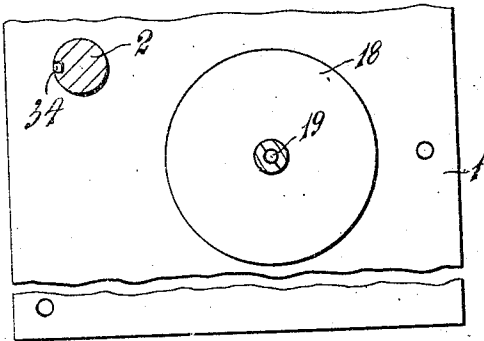

FIG. 3.

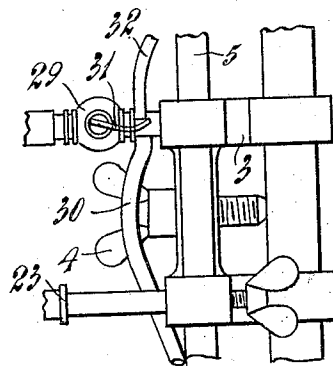

FIG. 4.

Witnesses  
*Charles Crompton*  
*Fred Lj. Pohl*

*Chas W. Seymour*  
 Inventor.  
 By *Weydon Maske*  
 Attorney.

# UNITED STATES PATENT OFFICE.

CHARLES WILLIAM SEYMOUR, OF CHRISTCHURCH, NEW ZEALAND

APPARATUS FOR CASTING METALS AND THE LIKE.

1,101,816.

Specification of Letters Patent.

Patented June 30, 1914.

Application filed October 8, 1913. Serial No. 794,116.

To all whom it may concern:

Be it known that I, CHARLES WILLIAM SEYMOUR, a citizen of the Dominion of New Zealand, and residing at Colombo street, Christchurch, in the Provincial District of Canterbury, in the Dominion of New Zealand, have invented certain new and useful Improvements in Apparatus for Casting Metals and the like, of which the following is a specification.

This invention relates to apparatus used for casting metals and more particularly for dental castings or castings required by jewelers and provides means whereby such castings can be produced in a more expeditious manner than heretofore.

The invention consists in mechanism wherein adjustment of the various parts to suit different sizes of cylinders used for casting can be performed in one operation; and in improved means for admitting compressed air to the top of such cylinder for forcing the metal into the mold.

With the apparatus at present employed the element of chance is not eliminated, and great care is necessary to insure good results, but by my invention the best results are obtained with a minimum of risk.

The invention is illustrated in the drawing wherein:

Figure 1 is a side elevation. Fig. 2 is an end elevation partly in section. Fig. 3 is a sectional plan on A. A. Fig. 1. Fig. 4 is a part end elevation illustrating a modification.

The base plate, 1, has a vertical standard, 2, on which is mounted a bracket, 3, adjustable vertically, and secured in position by a set screw, 4. A plunger, 5, slidable upon the bracket is pivoted at 8 to a hand lever, 9, the end of which is jointed at 10, to a link, 11, the opposite end of said link being pivoted at 12 in the bracket, 3. A two-way cock, 13, attached to the bracket is in communication through a pipe, 14, with a tank or main, containing compressed air. An arm, 15, upon the plug of the tap is adapted to be struck and actuated by a striking rod, 16, projecting from the lever, 9. A tube, 17, leads from a portway in bracket, 3, which is in communication with lock, 13, to a cap, 18 attached to the lower end of the plunger which has a central portway, 19. A cylinder, 20, containing the mold, 21, wherein the object is to be cast is placed within

a recess formed in the base plate and is adapted to be closed by said cap 18, which carries in a recess a pad, 22, of asbestos for the purpose of forming a tight joint. An arm, 23, extending from bracket, 3, supports a blow pipe, 24, employed for melting the metal to be cast, such blow pipe 24 being supplied with gas through a pipe 25. The blow pipe is also in communication with the compressed air supply through a pipe, 26, leading to the cock, 13. A set screw, 33, projecting into a vertical slot, 34, in standard, 2, prevents rotation of the bracket.

In operation the plunger is raised by means of the lever, and the cylinder containing the mold, and above it the metal to be melted is placed within the recess in the base plate. The blow pipe is then made to play upon and melt the metal, the lever is then depressed, and the cap forced tightly down upon the top of the cylinder. During the descent of the plunger, the plug of the cock is turned by the striking rod, 16, engaging the arm, 15, whereby the air is shut off from the blowpipe, and simultaneously admitted through tube, 17 to the interior of the cylinder, the pressure therein forcing the molten metal through a gate, 27, into the recess, 28, of the mold, a sound and accurate casting being thereby obtained. The standard has indicating markings upon it, and the bracket is adjusted relatively to one of these marks according to the size of cylinder being used. When a main supply of compressed air is not available the modification illustrated in Fig. 4 may be made in the apparatus; a single way cock, 29, instead of a "two way" cock being employed. A pipe, 30, connects the cock with the cap of the mold, and an arm, 31, upon the plug of the cock is adapted to be engaged by a striking rod, 32, and to cause compressed air to pass into the mold when the lever previously described is depressed. In this case the blowpipe is operated by a bellows in the usual way.

What I do claim and desire to secure by Letters Patent of the United States is:

In a machine of the class described the combination of a cylinder to contain a mold, a vertical standard, a bracket longitudinally adjustable on said standard to suit the size of cylinder used, a plunger reciprocable in said bracket, a cap on the end of said plunger adapted to close said cylinder, a two-

way cock mounted on said bracket, means for  
supplying compressed air to said cock, a  
blow pipe mounted on said bracket, means  
for supplying gas to said blow pipe, a pipe  
5 connecting said blow pipe to one outlet of  
the two-way cock, an independent pipe con-  
necting the other outlet of the two way  
cock to the cap, a lever for operating the  
plunger, and a striking rod on said lever  
10 for diverting the compressed air from the

blow pipe to the cap, when the plunger de-  
scends, for the purpose set forth.

In testimony whereof I have signed my  
name to this specification in the presence  
of two witnesses.

CHARLES WILLIAM SEYMOUR.

Witnesses:

C. H. SEYMOUR,  
G. A. J. HART.