



(12) **EUROPEAN PATENT APPLICATION**

(88) Date of publication A3:
02.09.2009 Bulletin 2009/36

(51) Int Cl.:
B25B 23/04^(2006.01) B25C 1/18^(2006.01)

(43) Date of publication A2:
14.05.2008 Bulletin 2008/20

(21) Application number: **07021660.1**

(22) Date of filing: **07.11.2007**

(84) Designated Contracting States:
AT BE BG CH CY CZ DE DK EE ES FI FR GB GR HU IE IS IT LI LT LU LV MC MT NL PL PT RO SE SI SK TR
 Designated Extension States:
AL BA HR MK RS

- **Miyazawa, Masamichi**
Anjo-shi
Aichi-ken (JP)
- **Shibata, Yoshinori**
Anjo-shi
Aichi-ken (JP)

(30) Priority: **08.11.2006 JP 2006302560**

(74) Representative: **Kramer - Barske - Schmidtchen**
European Patent Attorneys
Landsberger Strasse 300
80687 München (DE)

(71) Applicant: **Makita Corporation**
Anjo-shi, Aichi-ken (JP)

(72) Inventors:
 • **Ukai, Tomohiro**
Anjo-shi
Aichi-ken (JP)

(54) **Power tool with fastener guide member**

(57) A screwdriver (1) includes a guide member (2) for guiding a screw strip (7) that carries a plurality of screws (7b) arranged at intervals along a length of the screw strip (7). A feeding device (6) feeds the screw strip (7) such that the screws (7b) of the screw strip (7) are positioned one after another to oppose to a position for driving by a driver bit (5g). The guide member (2) defines

an arc-shaped guide path having a length, so that the screw strip (7) can move along the guide path. The guide member (2) is configured such that the length of the guide path can be varied at least between a first length and a second length that is longer than the first length. The present invention may also be applied to power tools for driving nails and rivets.

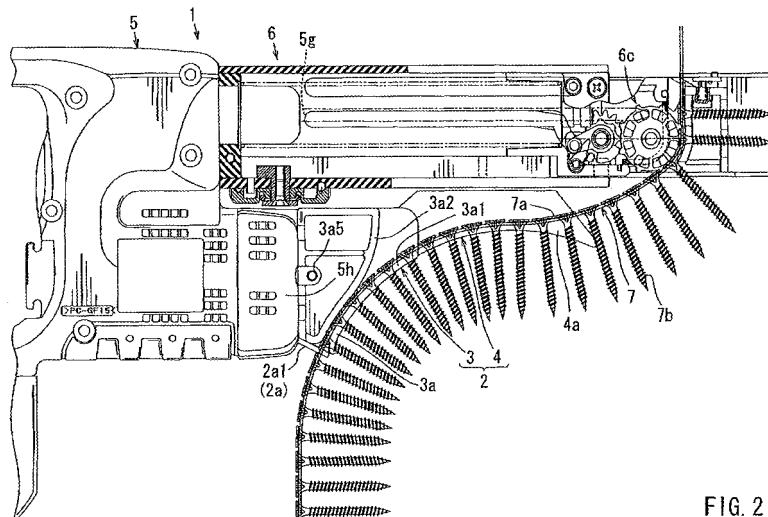

FIG. 2



EUROPEAN SEARCH REPORT

Application Number
EP 07 02 1660

DOCUMENTS CONSIDERED TO BE RELEVANT			
Category	Citation of document with indication, where appropriate, of relevant passages	Relevant to claim	CLASSIFICATION OF THE APPLICATION (IPC)
D,X	JP 08 155847 A (HITACHI KOKI KK) 18 June 1996 (1996-06-18) * figures 4,6 * -----	1,7,14, 15	INV. B25B23/04 B25C1/18
D,X	JP 05 104456 A (SANPU SHOJI KK) 27 April 1993 (1993-04-27) * figures 1,2,8 * -----	7,14,15	
			TECHNICAL FIELDS SEARCHED (IPC)
			B25B B23P B25C
The present search report has been drawn up for all claims			
Place of search The Hague		Date of completion of the search 20 July 2009	Examiner Klein, A
CATEGORY OF CITED DOCUMENTS X : particularly relevant if taken alone Y : particularly relevant if combined with another document of the same category A : technological background O : non-written disclosure P : intermediate document		T : theory or principle underlying the invention E : earlier patent document, but published on, or after the filing date D : document cited in the application L : document cited for other reasons & : member of the same patent family, corresponding document	

3
EPO FORM 1503 03.02 (P04C01)

**ANNEX TO THE EUROPEAN SEARCH REPORT
ON EUROPEAN PATENT APPLICATION NO.**

EP 07 02 1660

This annex lists the patent family members relating to the patent documents cited in the above-mentioned European search report. The members are as contained in the European Patent Office EDP file on
The European Patent Office is in no way liable for these particulars which are merely given for the purpose of information.

20-07-2009

Patent document cited in search report		Publication date	Patent family member(s)	Publication date
JP 8155847	A	18-06-1996	NONE	

JP 5104456	A	27-04-1993	NONE	

EPO FORM P0459

For more details about this annex : see Official Journal of the European Patent Office, No. 12/82