

(43) Date of A Publication 29.06.1994

(21) Application No 9226871.3

(22) Date of Filing 23.12.1992

(71) Applicant(s)

Stipton Limited

(Incorporated in the United Kingdom)

**The Warehouse, Winters Bridge, Portsmouth Road,
THAMES BITTON, Surrey, KT7 0BR, United Kingdom**

(72) Inventor(s)

Christos Rugeris

(74) Agent and/or Address for Service

S Turner-Dauncey

**The Warehouse, Winters Bridge, Portsmouth Road,
THAMES DITTON, Surrey, KT7 0BR, United Kingdom**

(51) INT CL⁵

E04H 15/46

(52) UK CL (Edition M)

E1D DF155 DF156 DGS2 D2019 D427

U1S S1734

(56) Documents Cited

EP 0341742 A1

(58) Field of Search

UK CL (Edition L) E1D DF155 DF156 DF157 DF158

DGS

INT CL⁵ E04H

(54) Pre-assembled collapsible tent

(57) A pre-assembled tent has a frame of square-section members lockably hinged at 1 and 4 and telescopically extendable/retractable at 6, all of these members being permanently assembled, as by pockets 2, into outer canvas O with an integral groundsheet OO, the whole tent being collapsible so as to form a pack A with the frames inside and the groundsheet OO outside. A variant (Fig.2) has a common apex 1 with four radially extending frame members, windows 12, doors, air vents 8, and awnings can all be incorporated as integral parts.

Fig. 1.

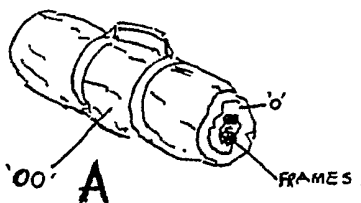
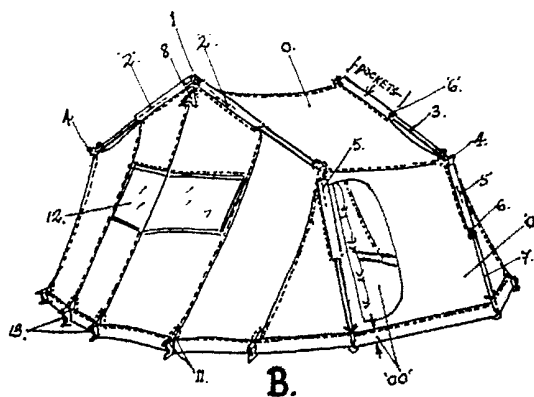
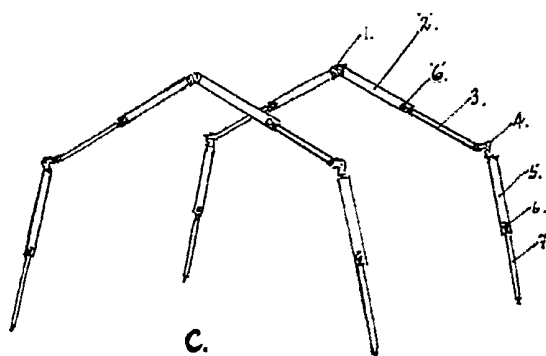

Fig. 1.

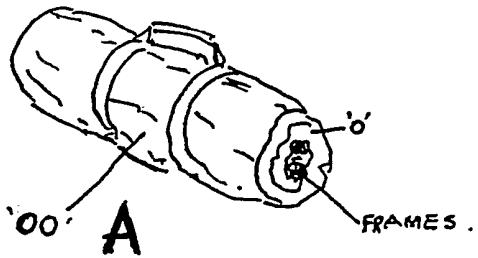
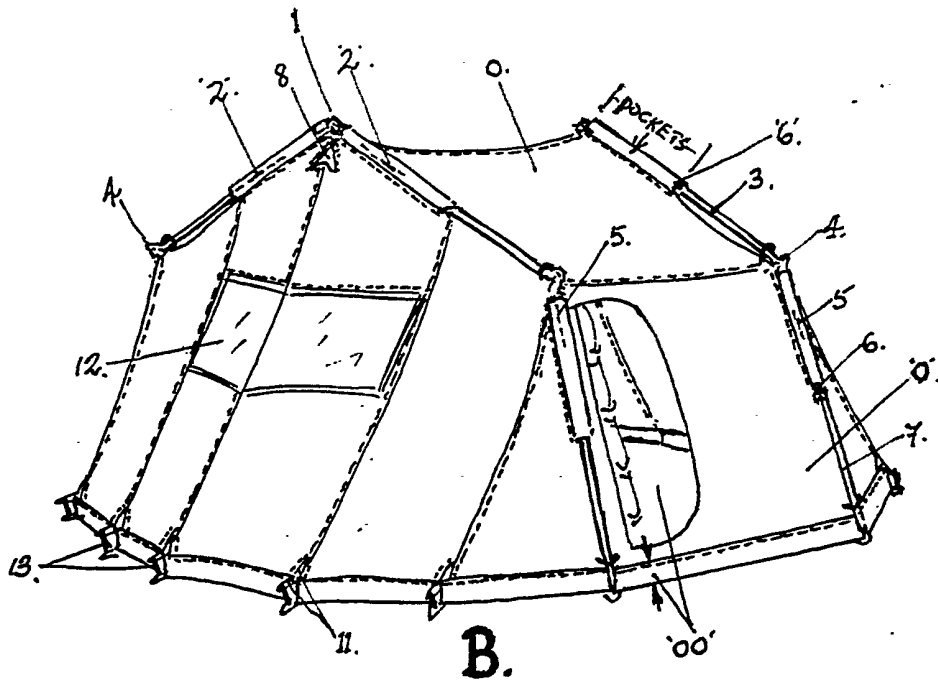
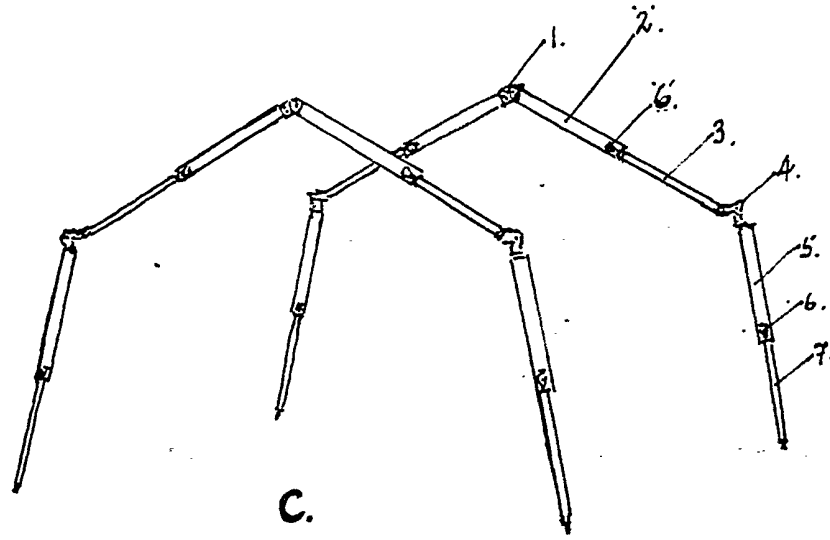

Fig. 2.

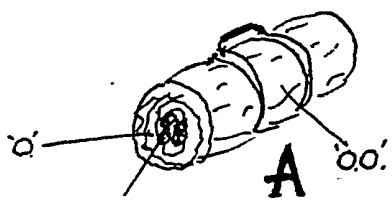
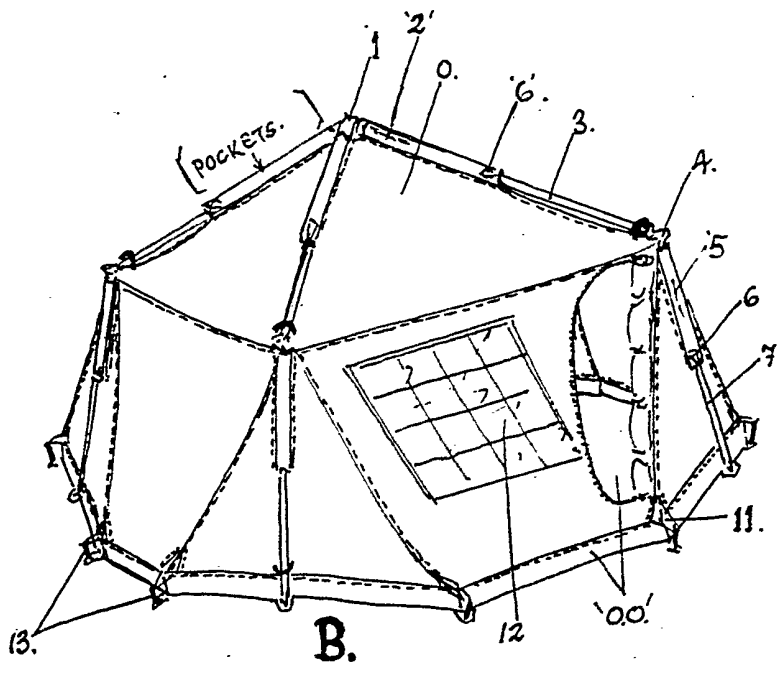
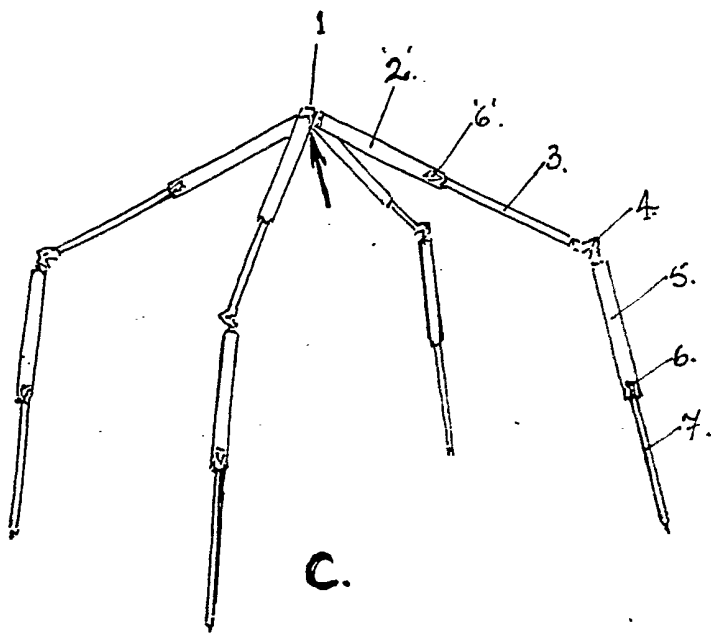

Fig. 3.

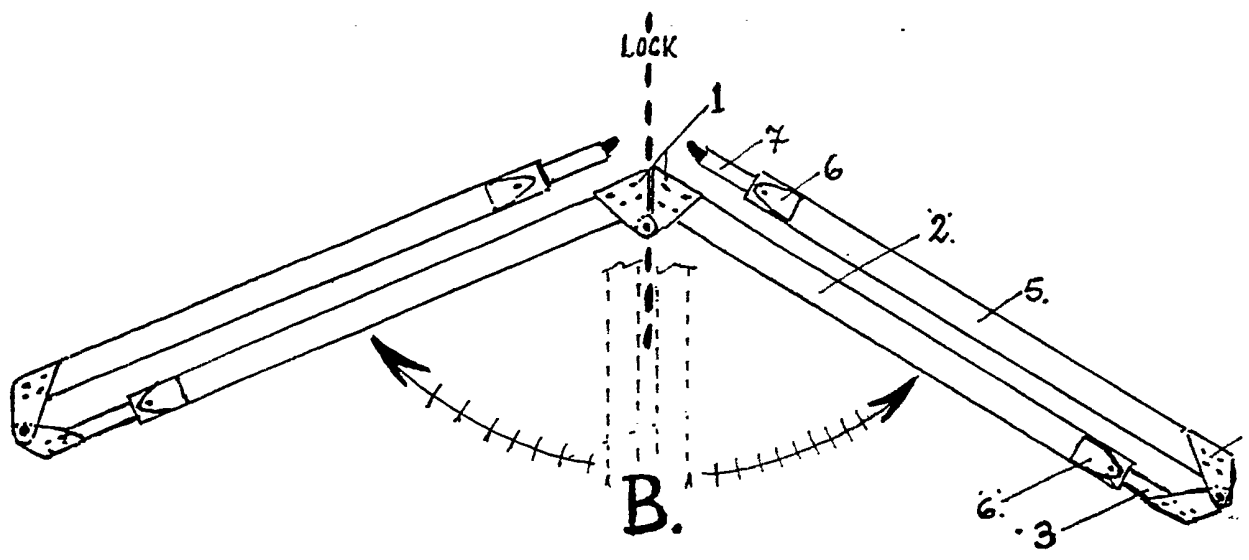
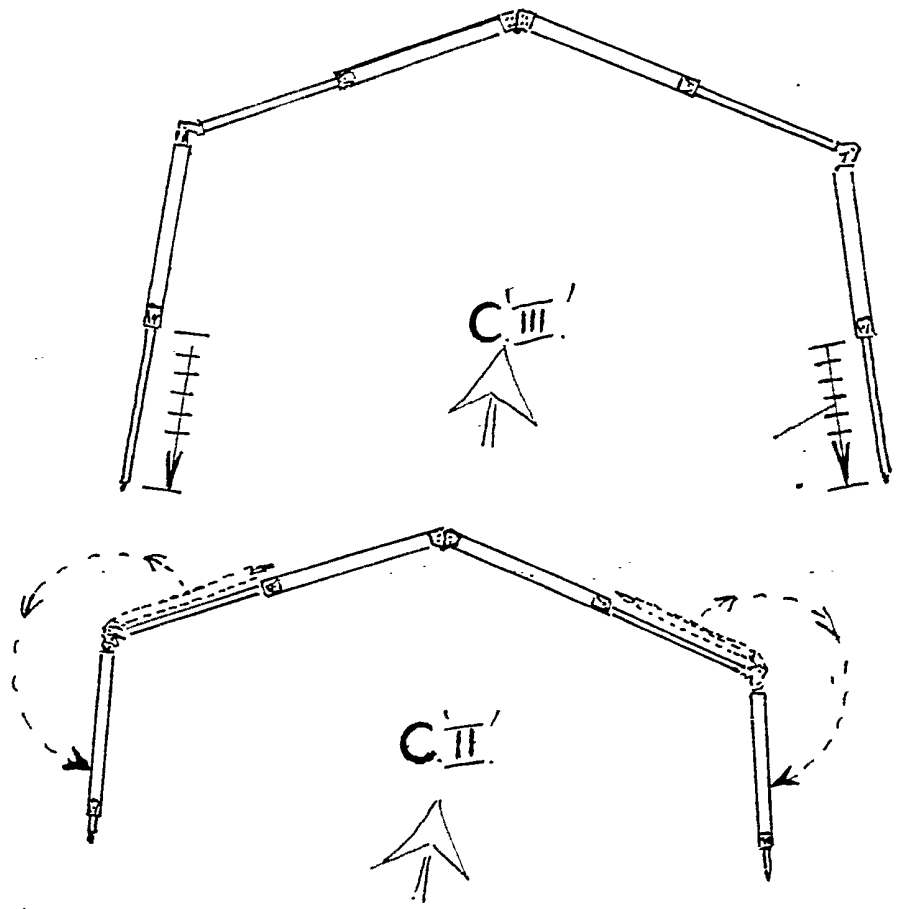
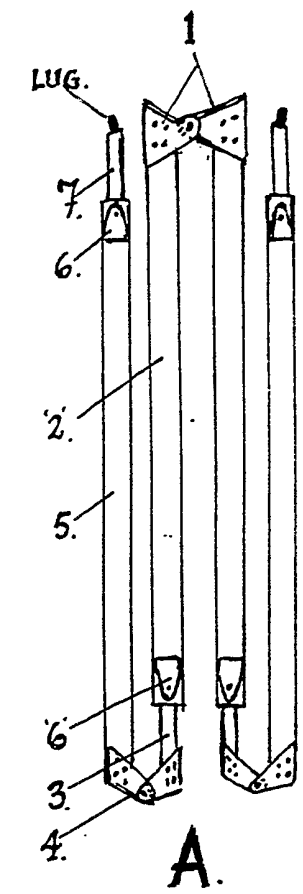
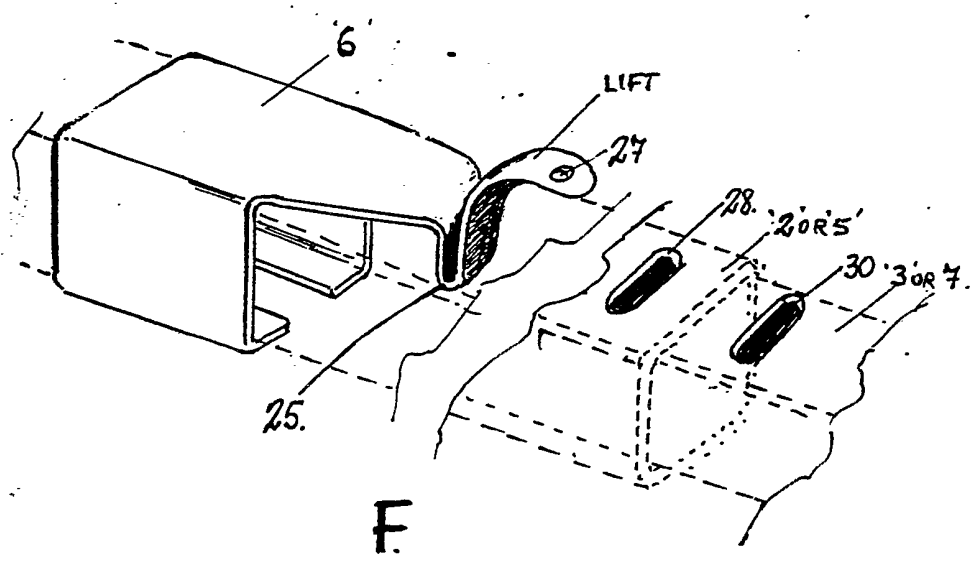
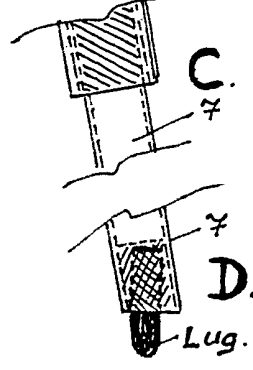
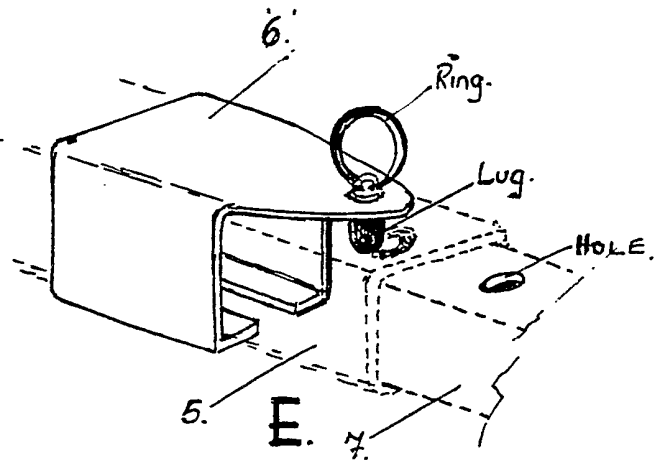
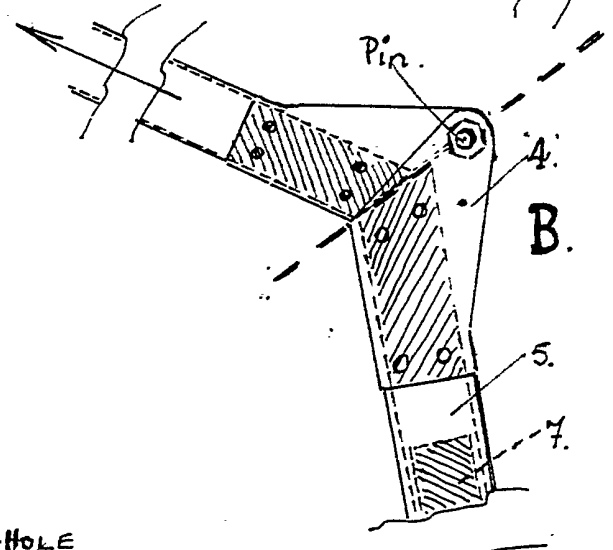
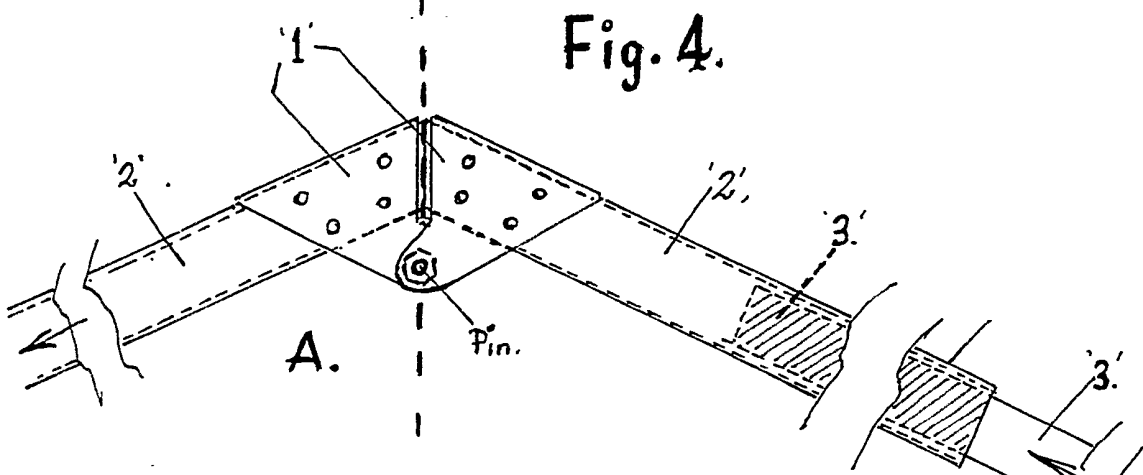

Fig. 4.



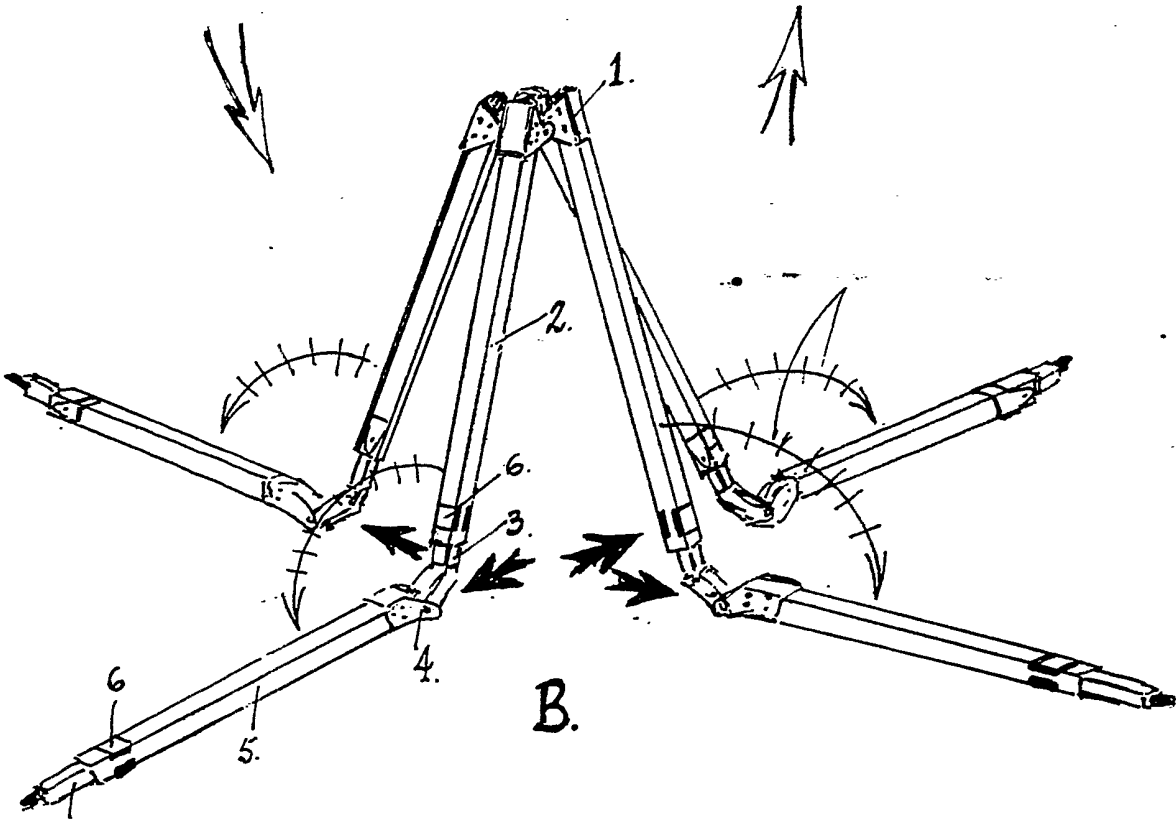
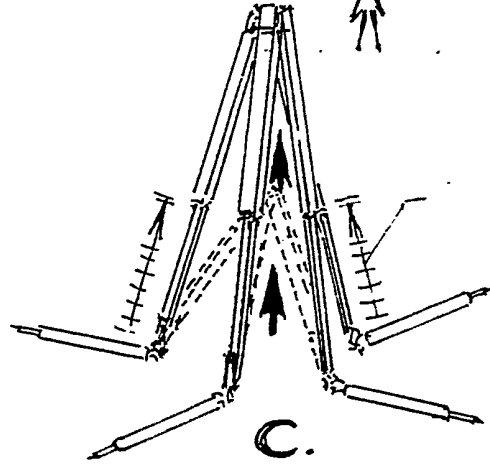
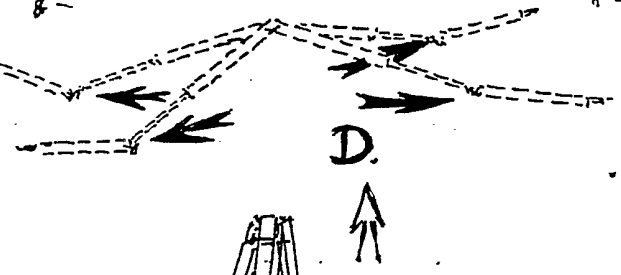
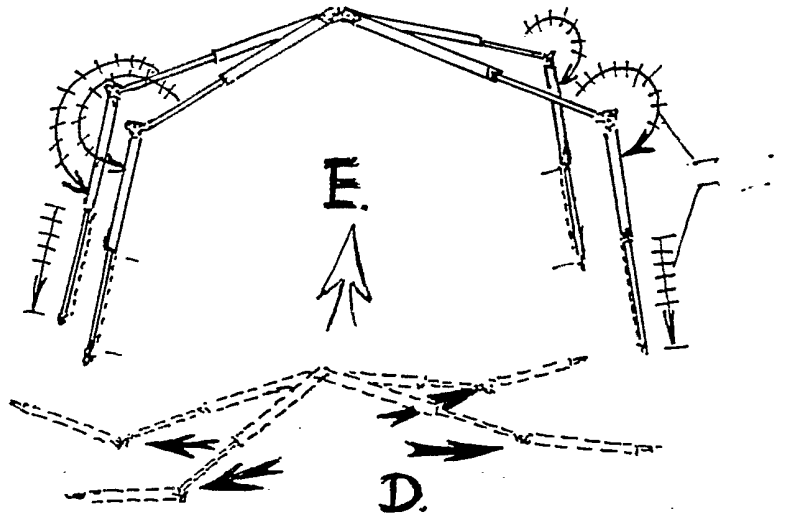
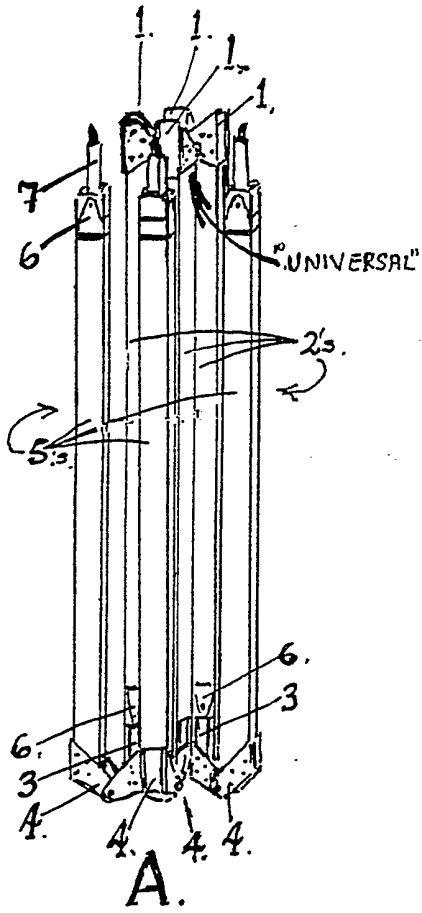

Fig. 6.

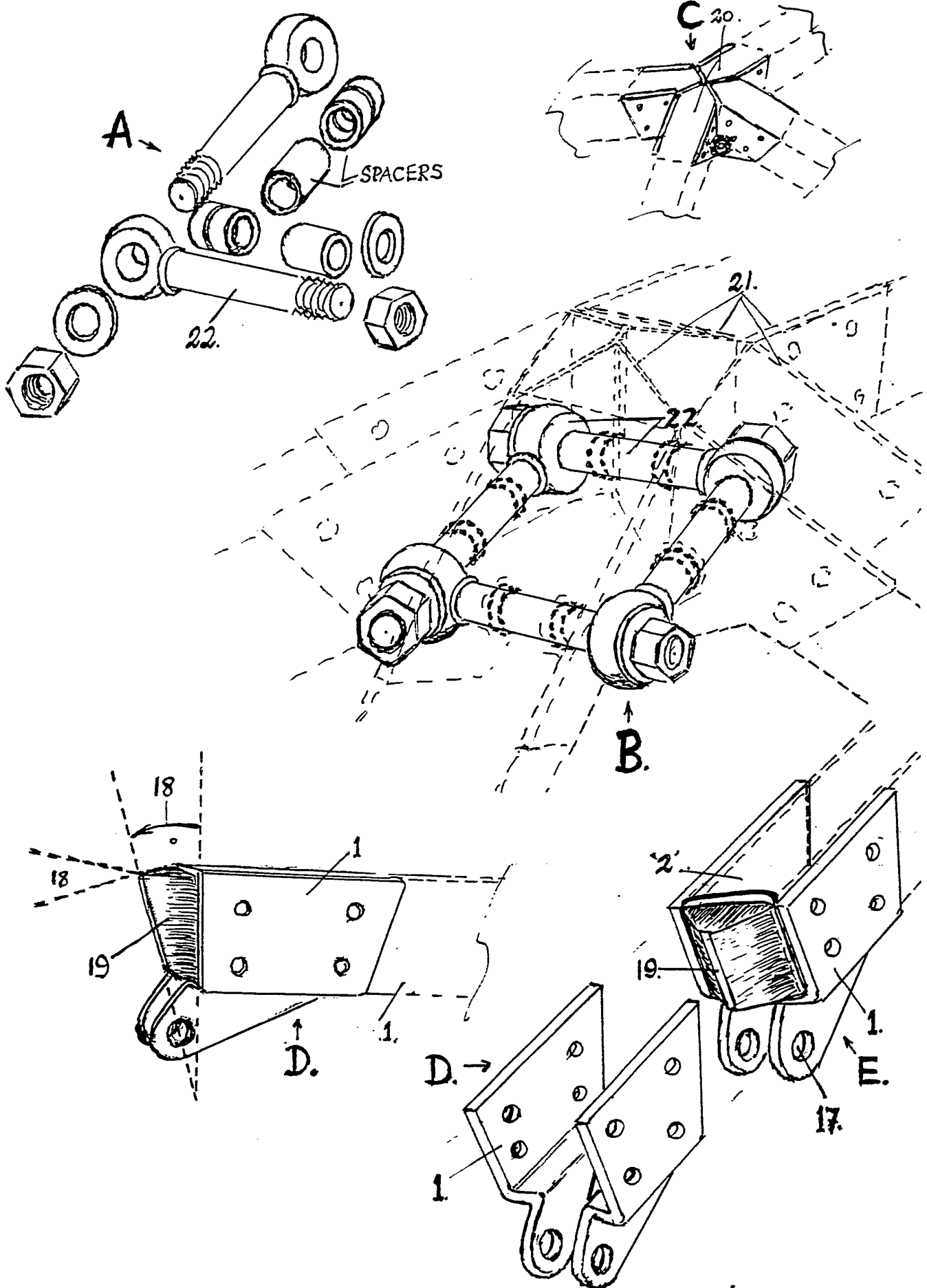
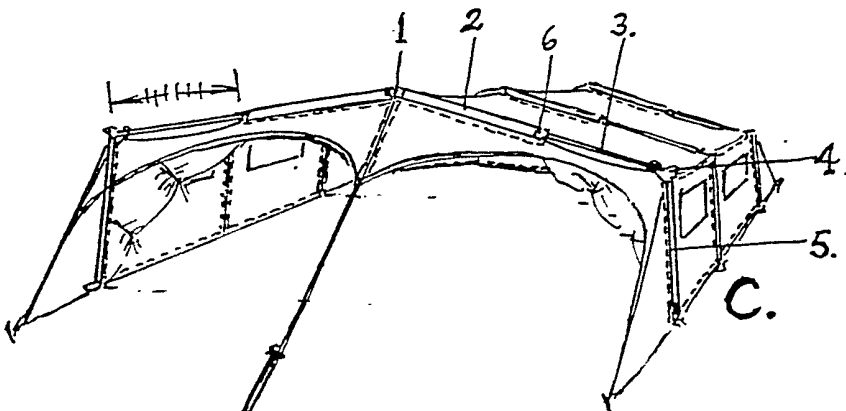
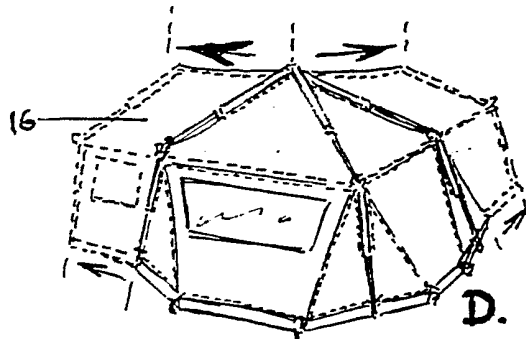
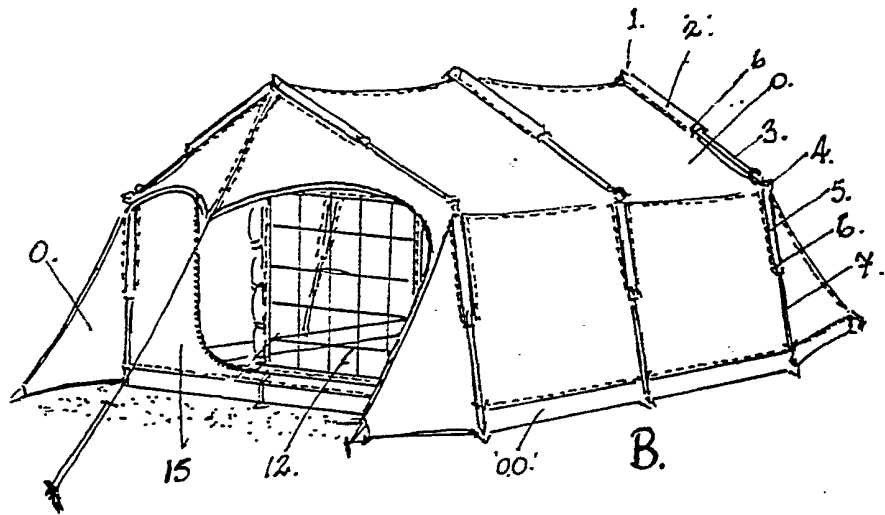
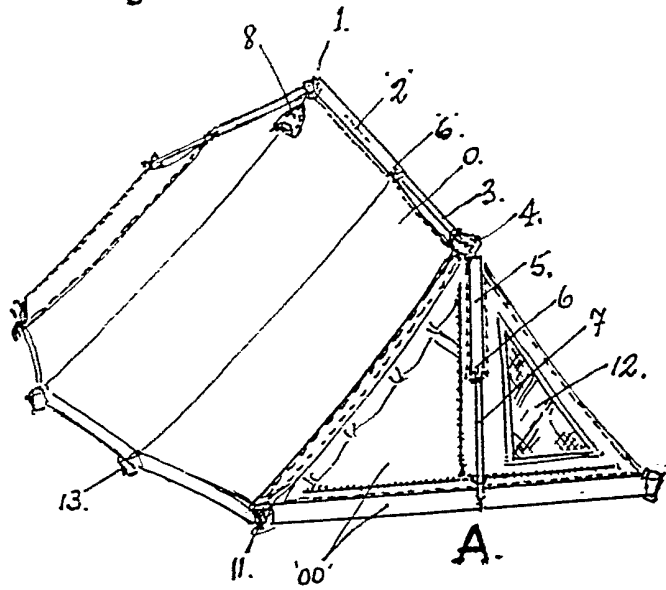

Fig. 7.



(PANEL A)

PRE-ASSEMBLED WORKS IN "READY TO STAND MODE" IE :TENT

TECHNICAL FIELD :

This invention relates to a quick and simple method of Erecting and Collapsing an already pre-assembled unit design of integral Fully sewn-in interconnected type of telescopic functioning frame works when supplied, (eliminating the need for the user to do any assembly work).

BACKGROUND :

Normal conventional types of known "Family Frame Tents" may vary in shape and colour, but all have the very same mode of production and supply design methods involving :-

- A) Frame works supplied in (disassembled bits and pieces state) in a bag, with instructions; of how to be (assembled by the user).
- B) The canvas covering material is likewise supplied in a similar way :- (in a separate bag) and with detailed instructions of how to pull over / and where to tie many securing points to frame etc.
- C) Optional Ground Sheet, and or inner dividers (if needed) may then (after the above A & B has been done) be put in separately also by the user. Worthy of note, is the fact that only the inner divided area can have a fully sewn-in ground sheet (not so though the remainder, which can not) ; thus would be ineffective in keeping undesirables out, or water running in at ground level in storm conditions.
- D) If it were of necessity the need to erect in stormy conditions, the above procedure inherently has many impracticalities ie ; at best $\frac{1}{2}$ Hour is required to erect totally in good weather, let alone the problems related with the above (loose canvas in the wind) and the time required, whilst everything is getting saturated, including the ground that will be the interior ?
- E) A further point to consider, in Countries such as America, Australia, Africa, where families usually cover vast distances holidaying, which require many over-night stops going / or returning / Surely these laborious methods are unsuitable.

Cont/.....2

ESSENTIAL TECHNICAL FEATURES :

According to my present invention there are obvious benefits to consider, as one compares above "Background" A,B,C,D and E with the following features :-

- * The entire complete unit is in a pre-assembled ready mode and is supplied in a single pack when manufactured and sold.
- * It does not require any assembly what so ever.
- * It does not contain any loose bits and pieces.
- * It has a totally fully sewn in ground sheet throughout.
- * Also room dividers permanently in place.
- * To erect in any sought of weather, it simply unroll's / unfolds / opens outwardly by lifting / extending self locating telescopics / and pegged down (in +- 3 Minutes), attaining a completely sealed and dry area to move into.

EXAMPLE :

Specific embodiments of the invention will now be described by way of examples, with reference to the accompanying drawings in which.

Fig 1.

- C) Shows in perspective (two over frames) as would be in erected stance, and position of extended telescopics in relation to each other ie : Separated without any outer covering :- commencing with Hinged Apex Swivel Connector '1' Top outer telescopic tubular piping. '2' Its self locating spring clip '6' Its inner inserted tubular piping. '3' Hinged pivoting side-wall connector '4' The top outer piping of side-wall. '5' Its self locating spring clip '6' Inner telescopic tubular piping '7' and end of leg and lug.
- B) Shows in perspective (two over frames as in 'C') in complete sewn-in state (with outer covering and sewn-in ground sheet), in erected stance, pegged to ground :- The said covering consists of (canvas covering '0') / (P.V.C Ground sheet '00'). P.V.C. clear window '12' /re-enforced pegging ties '11' /over sewn sleeves/ "Pockets" to take piping '2' & '5'. /roof vent '8'.

Cont/.....3

Fig 1.

- A) Shows the entire collapsed packed outfit in closed pre-assembled ready mode :- ie : Canvas and frame "enveloped by it's own ground sheet" '00' .

Fig 2.

- C) Shows in perspective (an alternate model) in erected stance without outer covering, identical to the two over frames as in Fig.1, but in "Cross-over mode", using a different type of Universal Connector at Apex (see fig 6).
- B) In perspective the above "cross-over mode", in full erected state complete with outer covering '0' and fully sewn-in ground sheet '00', pegged to ground.

- A) The (entire collapsed, packed outfit) in closed/pre-assembled ready-mode :- canvas and frame/enveloped by its own ground sheet '00'.

Fig 3.

A,B /CI, CII, CIII, - Displays method/ from folded, to fully erected stance.

- A) Shows (one complete) inter-connected "over frame" in folded stance, as follows :-
- * Commencing at its top / the hinged Apex swivel connector '1' affixed to the ends of outer square tubular roofing piping '2' attached self-locating spring clip '6' and with its incerted inner telescopic tubular piping '3' to which is affixed the side-wall swivel connector '4' which also holds top of side wall outer tubular piping '5'. together with its inner telescopic piping '7' / which self locate by means of spring clip '6' (end of leg has a lug).
- B) (This is the above frame 'A')- Commencing its method of unfolding to erect :- arch-fish-bone & arrows display line of movement outwards, until the Apex Swivel connector stops at "lock" position (see heavy dotted line) "lock".

Cont/.....4

Fig 3.

- C'I') Shows by means of Fish-Bone-lines & arrows the inner telescopic '3' extended to self locate spring clips '6'.
- C'II') Shows (both side wall frames '5' pivot over & down by arch dotted line arrows/ forming vertical side walls (as if legs) position) and to self lock the side wall pivot connector. (see fig 4 heavy dotted line).
- C'III') Displays final movement :- the inner side-wall telescopic '7' extending downwards (fish-bone-line arrows) to self locate spring clip '6'.

Fig 4.

Generally gives more details of the functions and workings of said over frames and component parts including Two types of self locating spring clips '6' (either of which may be used).

- A) Shows a pair of pinned Apex Swivel connectors '1' (as in erected stance) and Angle-locked by means of its designed pre-cut-angle (heavy dotted line) which determines the desired slope of roofing. Apex connectors are affixed to the square outer tubular piping '2', and inserted into inner tubular telescopic (shaded '3') through break display/ at other end of '2' (and inner telescopic '3' insert) - Continue to adjoining : (B)-
- B) Shows the side wall hinged pivot swivel connector '4' as in erected stance locked at pre-set angle (heavy dotted line) and further affixed there-on to top end of side-wall outer tubular piping '5' also (in shaded areas) its inner telescopic '7' and through breaks C7 / to ('D'), which shows bottom end of inner tele '7' and lug.
- E) Shows a square self-locating spring clip '6' with locating lug and pull-ring. Dotted lines display the inner and outer square tubular piping with aligned holes to self locate lug.
- F) Shows an alternative design spring-clip ie : having a bend '25' "as locator" instead of a lug, which self locates into desired position through slots '28' and '30' on telescopics.

Cont/.....5

Fig 5.

- A) Shows in perspective a complete two 'over-frame' of (cross over mode as used in Fig 2) in folded stance; * Joined by the Apex inner universal connector (as shown in fig 6)*.
- B) Shows the "cross-over" model in vertical stance :- Heavey arrows show legs slightly moved outwardly - and to commencing method of unfolding, by dropping outwardly all four side-wall legs (fish-bone-arch arrows).
- C) Shows how all four roofing telescopic "extend fully to self locate spring clips '6' by a lifting motion (fish-bone arrows) :- and by upwards heavey arrows: (leaving side walls at ground level).
- D) Heavey arrows show how all four already extended roof piping are then pushed outwardly, / until the Apex inter-universal self locks. (see fig.6.B22).
- E) Shows two movements :- pivoting all side-wall piping over-and-down (arched Fish-bone arrows) until locked/ and extending all legs inner-telescopic- (straight Fish -bone arrows) to self locate spring clips '6'.

Fig 6.

(The Inter-Universal Connector)

- A) Showing details of Design of pins with opposite male/female ends '22'. Also Showing only two of the four pins required / * washers, nuts and some relevant spacers needed.
- B) Shows solid lines '22' the four pins as in assembled state (minus spacers) and displaying by dotted lines '21' the over frame Apex's in cross-over mode "inter locked" on their respective "bevels-and-angles", (designs as seen D '18' and '19').
- C) Shows perspectives of the Apex piping connectors in cross-over lock position.
- D) Shows swivel connector '1' (dotted lines) angles '18' and bevel angle '18'.
- E) Shows in perspective, outer piping '2' -with insert solid '19' and swivel connectors '1' also hinged hole '17' to take pin A 22.

Cont/.....6

Fig 7.

Basically shows some variations relating to the use of (stated over-frames).

- A) Showing use of just (one only over-frame) in use (as in a "ridge Type Tent") displaying how it forms a second-hump- Apex '1' creating added height.
- B) Showing how with one additional over-frame to Fig.1 ie : forming a possible Vertical wall '15' with a veranda outlook etc.
- D) Shows a cross-over model (as in Fig 2) dotted lines, displays possible extensions :- by adding one only over-frame ('slightly shortened') and by extending canvas to form extra room or veranda.
- C) Two / Three/or more over-frames (of heavier size), Shows how by using telescopic only in (the roofing area) for possible marquee models ?.

(PANEL B)

Referring to the drawings the tent unit comprises of square tubular piping 2 and 3 of suited size diameter for use in telescopic action and are held hinged by swivel and or pivot preset designed angles '1' and '4' connectors, :- allowing certain functions of fold, or erecting Fig.4 'A' & 'B', resulting in desired angle-lock '1' and '4' and which also have self-locking spring-clips '6' for desired length of extending the inner telescopics '3'.

The entire designed "over-frames" (fig.1 and Fig.2) are able to be completely in a functional "pre-assembled" state (Fig.3 and Fig.5) totally sewn-in to outer covering materials (Fig.1 and Fig.2) also sewn to its relevant ground sheeting '00'.

* When folded :- (Fig 1A & 2A) the '00' ground sheet completely protects the outer covering material as it envelops totally all and sundry.

To erect from single pack (Fig 1A and 2A) unfolding / Follow procedures Fig.3 and 5. To fold, simply reverse sequences.

8

(PANEL C)

CLAIMS

1. Method of a "fully-(pre-assembled) square tubular telescopic piping pivoting to pre-set angle lock positions by means of their designed functional connectors see Fig 3 and Fig 4 A,B,C and D.
2. In connection with the above functions it is necessary to include "spring steel clips" Fig.4 E/and Fig.4 F/ and their use.
3. Method and design of above 1, and 2, are also incorporated within mode and methods inclusive in cross-over mode, (as described in Fig.5 A,B,C and D).
4. The inclusion of designed Fig.6 Apex Central "Universal-Inter-Connector"; as shown also in Fig.6 A,B,C,D and E,(in use for Claim.3) above.
5. Further to the above 1,2 and 3,claims/and relative to their designed functions and methods/to add to these (having them affixed) ie : integrally housed in pre-assembled ready mode within the outer covering material (permanently).
6. The use of all above methods / designs / which enables a fully sewn-in ground sheet or inner dividers to be in permanently.
7. Alternative possible variations as described Fig 7 A,B,C and D.
8. The use of the above designed methods and or functions / wether in use in sewn-in to outer covering material, or not.

Categories of documents

X: Document indicating lack of novelty or of inventive step.

Y: Document indicating lack of inventive step if combined with one or more other documents of the same category.

A: Document indicating technological background and/or state of the art.

P: Document published on or after the declared priority date but before the filing date of the present application.

E: Patent document published on or after, but with priority date earlier than, the filing date of the present application.

&c: Member of the same patent family, corresponding document.

Databases: The UK Patent Office database comprises classified collections of GB, EP, WO and US patent specifications as outlined periodically in the Official Journal (Patents). The on-line databases considered for search are also listed periodically in the Official Journal (Patents).