

Feb. 7, 1928.

1,658,338

J. S. JAMMER ET AL

TWO-WAY REPEATER

Filed June 30, 1924

2 Sheets-Sheet 1

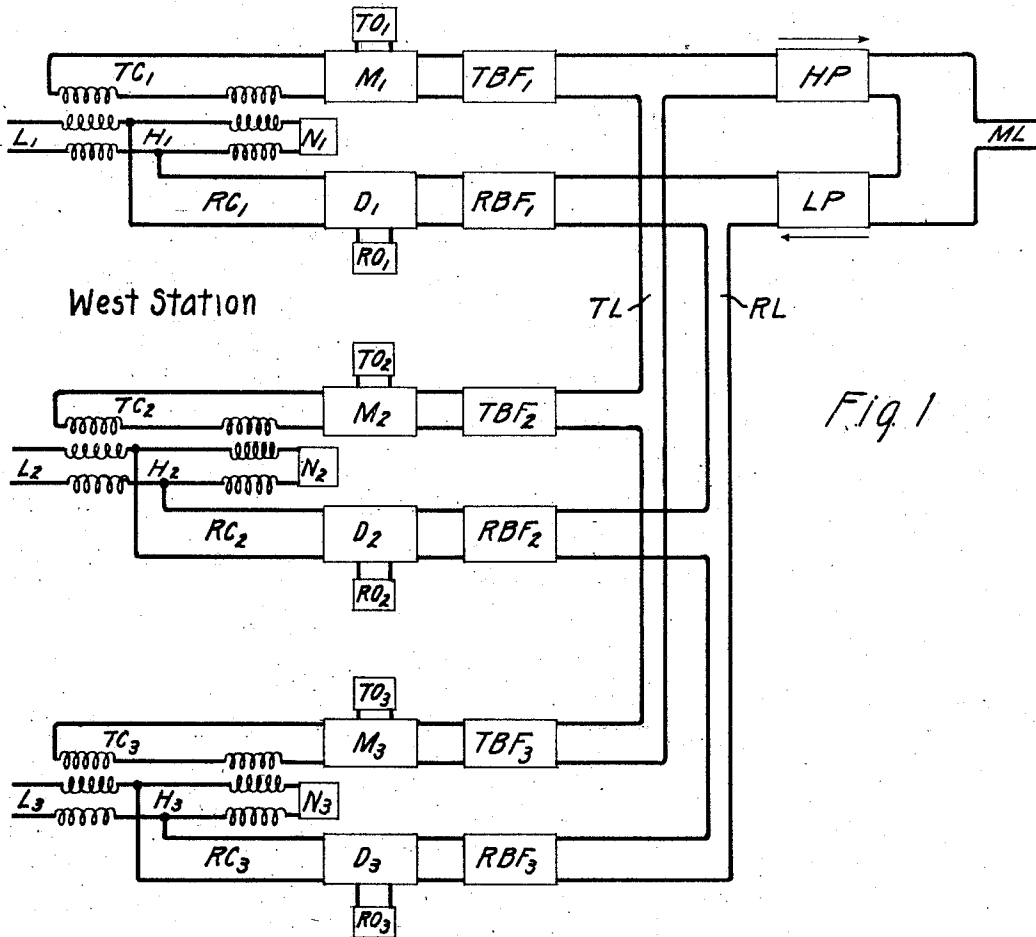

Fig 1

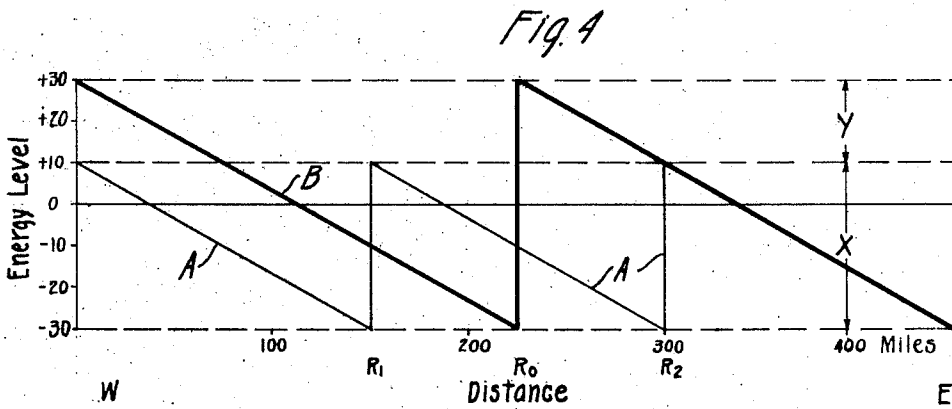

Fig. 4

Inventors:
Jacob S. Jammer
Charles W. Green

by E. W. Adam, Atty.

Feb. 7, 1928.

1,658,338

J. S. JAMMER ET AL

TWO-WAY REPEATER

Filed June 30, 1924

2 Sheets-Sheet 2

Fig. 2.

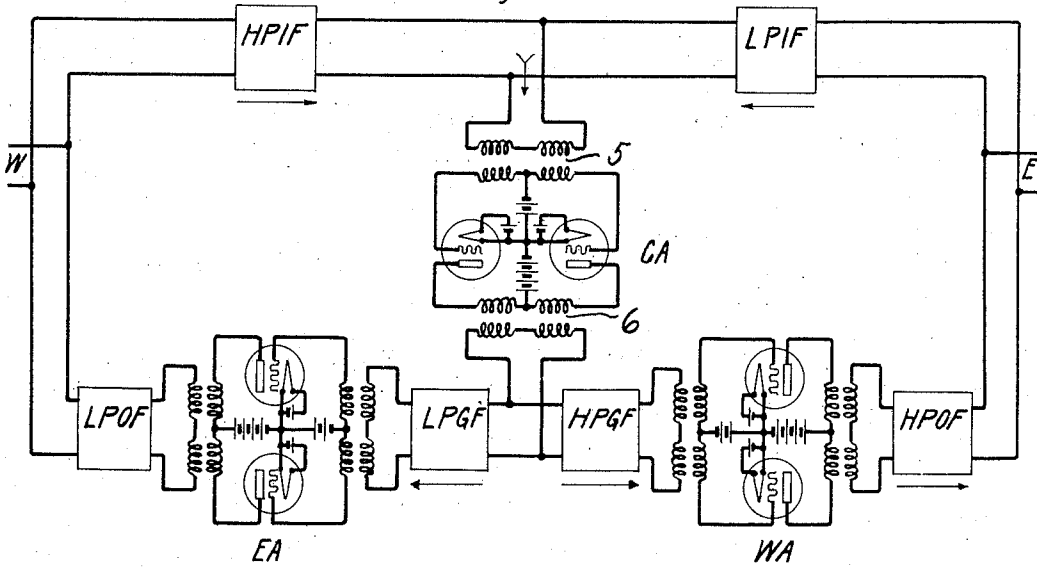
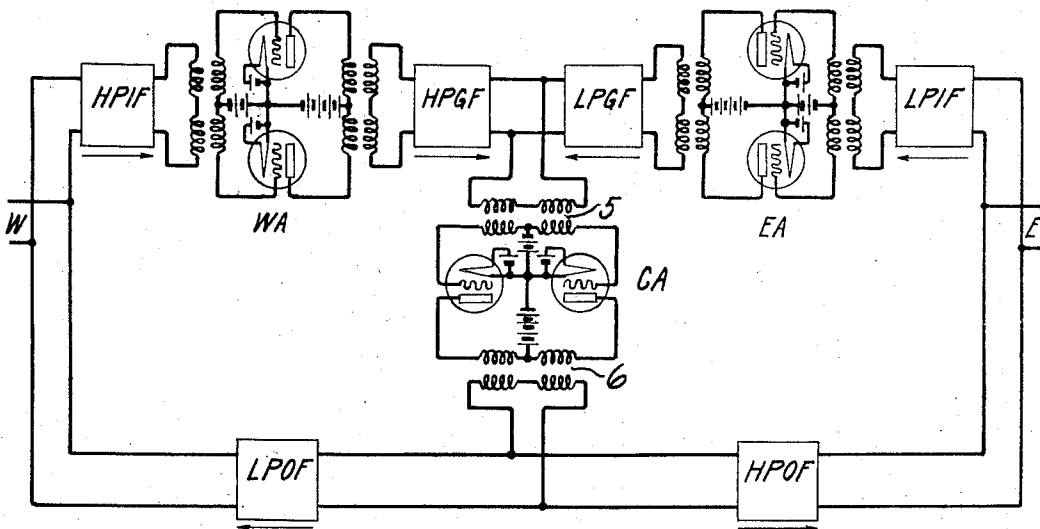

Fig. 3.



Inventors:
Jacob S. Jammer
Charles W. Green
by Edward Adams. Att'y.

UNITED STATES PATENT OFFICE.

JACOB S. JAMMER, OF NEW YORK, N. Y., AND CHARLES W. GREEN, OF MILLBURN, NEW JERSEY, ASSIGNORS TO WESTERN ELECTRIC COMPANY, INCORPORATED, OF NEW YORK, N. Y., A CORPORATION OF NEW YORK.

TWO-WAY REPEATER.

Application filed June 30, 1924. Serial No. 723,165.

This invention relates to two-way amplifying repeaters adapted for use in multiplex carrier current signaling systems.

An object of the invention is to produce an efficient and economical two-way repeater.

A related object of the invention is to increase the gain and level of a two-way amplifying repeater.

Repeaters of this type are employed in multiplex carrier current telephone and telegraph systems operated on a group frequency basis wherein the different channel frequencies for transmission in one direction are grouped in a different frequency range from that employed for transmission in the opposite direction.

The attenuation of currents of carrier frequencies resulting through their transmission over long distance lines is much greater than those of voice frequency, and the successful operation of carrier systems has heretofore depended on the use of repeaters at comparatively frequent intervals on the line.

The number of repeater points required in such a system may be reduced by increasing the amplification or gain of the individual repeater amplifiers, which are usually of the three-element vacuum tube type. However, merely increasing the amplification in repeater circuits of the types heretofore known, beyond a certain load limit, offers no advantage, since as the load is increased, tubes of greater load capacity are required with consequently greater initial cost and greater maintenance costs.

This invention reduces the number of repeater points in a commercial carrier current signaling system while at the same time actually reducing the number of amplifiers employed in the system so that a large geographical distance is spanned with a greater economy of apparatus than has heretofore been thought possible.

According to a feature of the invention the gain and level of a repeater are materially increased by arranging the amplifying structures in a novel manner to give increased economy and efficiency of operation. A common amplifier is provided for the two groups of frequencies for one stage of amplification, and individual amplifiers are provided for each group for another stage

of amplification. Each amplifier, may be utilized to its full capacity, the second stage amplifiers operating at a higher level than the first stage amplifiers. By suitably dividing the load between the individual amplifiers and the common amplifier for the two frequency groups, the same gain can be obtained with the same quality of transmission but with a smaller number of amplifiers.

The invention will be described as applied to a multiplex carrier current telephone system, although it will be understood that it may also be applied to other signaling systems.

The invention is susceptible of various modifications which are suited to the particular type of carrier system in which the repeater is to be employed. Certain modifications, for example, may be particularly adapted for use in the well-known carrier telephone suppression system, that is, the system in which the unmodulated carrier component is not transmitted, while other modifications are especially suited for use in carrier telephone systems in which the unmodulated carrier component is transmitted along with side band components.

The various features and advantages of the invention will appear from the following description and the accompanying drawings in which:

Fig. 1 is a diagrammatic view illustrating a terminal station of a carrier suppression telephone system.

Fig. 2 is a diagrammatic view of a carrier telephone repeater station embodying the invention.

Fig. 3 is a diagrammatic view illustrating a modification of the system of Fig. 2.

Fig. 4 shows curves illustrating the operating levels of the repeaters of Figs. 2 and 3.

Reference will first be made to Figs. 1 and 2, which, when placed side by side with Fig. 1 at the left, represent the west terminal station and a mid-line repeater of a carrier telephone system interconnected by the multiplex line ML.

The usual east terminal station, which is identical to the west terminal station shown in Fig. 1, is omitted for the sake of simplicity in the description.

The terminal apparatus at the west sta-

tion comprises a plurality of transmitting channels TC_1 , TC_2 and TC_3 , connected through a common transmitting circuit TL to the main line ML, and a plurality of receiving channels RC_1 , RC_2 and RC_3 , connected through a common receiving circuit RL to the main line ML.

Carrier currents are utilized for transmission over the line ML and are grouped as to their frequencies, the higher frequencies, as a group, being used for transmission from west to east, and the lower frequencies, as a group, being used for transmission from east to west.

A high pass grouping filter HP is paired with a low pass grouping filter LP at the terminal stations. These filters serve to separate the directional groups of carrier waves to the respective terminal transmitting and receiving circuits. These filters and each of the other filters shown throughout the system may be designed in accordance with the principles set forth in the United States patent to Campbell, No. 1,227,113, issued May 22, 1917. Specific types of both high and low pass filters are shown for example in Fig. 11 of the Campbell patent.

Low frequency lines L_1 , L_2 and L_3 , which may be telephone lines or other types of signaling lines, are associated with channels TC_1-RC_1 , TC_2-RC_2 and TC_3-RC_3 , respectively, for simultaneous and independent communication over the line ML with corresponding similar lines at the east station (not shown).

The low frequency lines are provided with balancing artificial lines or networks N_1 , N_2 and N_3 , respectively, and with differential repeating coils H_1 , H_2 and H_3 , commonly known as hybrid coils for enabling independent transmission in the two directions between the line and the high frequency terminal apparatus.

Transmitting channel TC_1 includes a modulator M_1 and a band filter TBF_1 . Similarly, transmitting channel TC_2 includes a modulator M_2 and a band filter TBF_2 , while channel TC_3 includes a modulator M_3 and a band filter TBF_3 .

Receiving channel RC_1 includes a demodulator D_1 and a band filter RBF_1 . Similarly, channel RC_2 includes a demodulator D_2 and a band filter RBF_2 , while channel RC_3 includes a demodulator D_3 and a band filter RBF_3 .

The modulators associated with the various transmitting channels throughout the system are of the balanced type disclosed in the U. S. patent to Carson, No. 1,343,306, issued June 15, 1920, designed to suppress the unmodulated carrier from transmission. The various demodulators may be of the well-known vacuum tube detector type shown in Fig. 49 of an article entitled "Carrier current telephony and telegraphy" by

Messrs. Colpitts and Blackwell published in the Proceedings of the American Institute of Electrical Engineers, vol. 40, 1921.

The carrier system outlined above is, as stated, of the type in which the carrier wave of each channel is suppressed from transmission when no signals are being sent, and when signals are being transmitted, modulation components of the modulated wave are sent over the line, but no unmodulated components of the carrier wave are transmitted. In order to reproduce the signal from modulated waves of this character, it is necessary that the carrier wave supplied to the demodulator at the receiver be of substantially the same frequency as the carrier wave which was suppressed at the transmitter. A system of this general character is described in connection with Fig. 49 of the Colpitts and Blackwell article, supra.

Carrier currents of the frequency assigned to channel TC_1 are supplied from a source TO_1 to the modulator M_1 , wherein they are modulated by voice frequency currents of other signaling currents from the low frequency L_1 . Carrier sources TO_2 and TO_3 are similarly associated with modulators M_2 and M_3 , respectively, while carrier current sources RO_1 , RO_2 and RO_3 are associated with demodulators D_1 , D_2 and D_3 , respectively.

As noted above, the carrier current sources RO_1 , RO_2 and RO_3 are necessary to supply to the incoming side bands in each receiving channel the carrier current which was suppressed at the transmitting end of the channel.

The various band filters associated with the terminal transmitting and receiving channels are so designed that they will transmit one of the side bands, either the upper or lower as desired, produced by modulation in the respective channels, and will suppress from transmission frequencies lying outside of such band.

Voice frequency currents originating, for instance, in the low frequency line L_1 at the west station pass through the associated hybrid coil H_1 , into the modulator M_1 in the transmitting channel TC_1 . There is likewise fed into the modulator the carrier current from the oscillator O_1 , as described above. Of the components of modulation appearing in the output circuit of the modulator M_1 , the transmitting band filter TBF_1 suppresses all except one side band, for example the upper side band, which it transmits or passes into the common transmitting circuit TL. The currents so transmitted from channel TC_1 and the other transmitting channels then pass through the high pass grouping filter HP to the multiplex line ML and thence through the repeater station to the east terminal where they are picked up by the high pass grouping filter thereat and

are thence transmitted to the respective receiving channels.

Currents incoming at the west station pass through the low pass grouping filter LP to the common receiving circuit RL, whence they are selected by the respective receiving band filters for transmission to the respective low frequency lines. Currents passing through receiving band filter RBF₁, for example, are combined in demodulator D₁ with carrier waves from source RO₁, and the voice frequency components of demodulation appearing in receiving channel RC₁ are transmitted through hybrid coil H, to the low frequency line L₁.

Fig. 2 illustrates a two-way repeater which is adapted to connect the west and east transmission line sections W and E. This repeater provides two stages of amplification in which a common amplifier is employed for the two groups of frequencies for the first stage of amplification, and individual amplifiers are employed for each group for the second stage of amplification.

As pointed out above, the currents transmitted from the west station, which are impressed upon the repeater from line section W, are comprised in a higher frequency group than those transmitted from the east station which are impressed upon the repeater from line section E.

The repeater consists of upper and lower repeater branches, which include one-way selective paths for each of the frequency groups. These selective paths include frequency discriminating filters which direct the incoming currents through the proper repeater channels. One amplifier is employed common to both of the selective paths for one stage of amplification and separate amplifiers are employed in each of the paths for the second stage of amplification.

The upper branch of the repeater includes a high pass input filter HPIF designed to pass frequencies of the upper group transmitted from west to east, and a low pass input filter LPIF designed to pass frequencies of the lower group transmitted from east to west.

A common amplifier CA has its input circuit coupled by means of a transformer 5 to the upper branch of the repeater at a point intermediate the high pass input filter HPIF and the low pass input filter LPIF. The output circuit of amplifier CA is coupled to the lower branch of the repeater by means of a transformer 6. The amplifier CA comprises two vacuum tubes of the three-element electron discharge type arranged in a so-called "push-pull" circuit so that distortion is practically eliminated. The principles of the push-pull type of circuit discussed at length in the United States Patent to Hartley, No. 1,494,905, issued May 20, 1924.

The lower branch of the repeater contains an amplifier WA for amplifying currents transmitted from west to east, and an amplifier EA for amplifying currents transmitted from east to west. In order to provide proper frequency separation between the upper group of frequencies to be transmitted through amplifier WA and the lower group of frequencies to be transmitted through the amplifier EA, a high pass grouping filter HPGF and a high pass output filter HPOF are associated with the input and output circuits of the amplifier WA, and a low pass grouping filter LPGF and a low pass output filter LPOF are similarly associated with the input and output circuits of the amplifier EA.

It will be seen from the above that the repeater shown in Fig. 2 includes one-way selective paths for each of the frequency groups. Currents incoming from the line section W pass through the high pass input filter HPIF and are amplified in the common amplifier CA. Currents of this particular group of frequencies appearing in the output of the amplifier CA are selectively passed through the high pass grouping filter HPGF to the west to east amplifier WA, and thence through the high pass output filter HPOF to the line section E. The currents comprised in the lower group of frequencies incoming from the line E pass through the low pass input filter LPIF and are likewise amplified in the common amplifier CA. These currents are selectively passed through the low pass grouping filter LPGF to the east to west amplifier EA, whence they are transmitted through the low pass output filter LPOF to the line section W.

The electrical and economical advantage of the above-described amplifier may be seen from a consideration of the curves of Fig. 4, in which energy level is plotted against distance.

The curve A of Fig. 4 represents the energy levels at which it has heretofore been possible to transmit currents between terminal stations W and E, while curve B represents the energy levels at which it is possible to transmit the currents between the same terminal stations in accordance with this invention. In both cases, the figures herein given are representative of a three-channel carrier telephone suppression system of the type described above, stations W and E being identical to the terminal station shown in Fig. 1. While these curves illustrate transmissions from station W to station E the same conditions apply to transmissions in the opposite direction.

It is customary in carrier current telephone practice to speak of the energy levels at which the carrier currents are transmitted in terms of miles of standard cable over

which the currents are transmitted at 800 cycles per second. The formula for miles, gain or loss, as the case may be, may be represented as follows:

$$M = 21.12 \log \frac{i_1}{i_2}$$

where i_1 represents the input current on the line, and i_2 represents the output on the line. For practical purposes it is customary to designate a point on the vertical scale of Fig. 4 as the zero level or zero miles gain from which the remainder of the scale may be calibrated. The point on the scale of Fig. 4 corresponding to zero miles represents an energy level of 4 mils in a 600 ohm circuit, or .01 watt, for a single channel system. For a three-channel system such as that herein described, however, zero miles represents an energy level of 6.8 mils in a circuit of similar impedance.

In three-channel carrier telephone systems it has been customary to impress the currents upon the transmission line at a level of plus 10 miles, or about 20 mils, as shown by the curve A, which shows the energy level at which the carrier currents are impressed upon the line at station W. As shown by the curve A, there is a considerable loss in energy caused by the attenuation of the carrier currents as they are transmitted over the main line. At a point 150 geographical miles from station W, the energy level has been reduced to -30 miles, or about .25 mils. At this point it becomes necessary to insert an amplifying repeater on the line since any further substantial loss would reduce the carrier currents to the noise level on the line. The repeater R_1 is, therefore, inserted to raise the level of the carrier currents back to plus 10 miles, or about 20 mils. It will readily be seen, therefore, that due to the attenuation of the carrier currents two repeaters R_1 , R_2 , must be inserted between terminal stations W and E on a line 450 miles in length.

In accordance with the invention the carrier currents may be transmitted over the system at high energy levels with a greater economy of apparatus than has heretofore been thought practicable. The carrier currents may be impressed upon the line at a terminal station, for example at station W, at an energy level of plus 30 miles by means of high power amplifiers, and these currents do not require amplification until they have been reduced to a level of -30 miles, at a point 225 geographical miles from station W. At this point the repeater R_0 , identical to that shown in Fig. 2 is inserted on the line. The carrier currents transmitted from station W in passing through the common amplifier CA are raised to an energy level of plus 10 miles indicated by the line x , without overloading this amplifier, and are then

further raised from an energy level of plus 10 miles to an energy level of 30 miles indicated by line Y, in the amplifier WA, which amplifier operates at higher energy levels than the amplifier CA. This amplifier, for example, and also amplifier EA, may consist of larger tubes than those employed in the amplifier CA of this figure. At the same time, carrier currents transmitted from station E to station W are amplified in the common amplifier CA and in the east to west amplifier EA at the repeater point R_0 .

The above-described arrangement provides a repeater which may be economically manufactured and maintained. In the suppression type carrier system which is illustrated in the drawings the load on the common amplifier CA would never be greater than the total number of one-way channels, because while it is possible to transmit in both directions, the parties at the ends of a circuit do not talk simultaneously.

The repeater illustrated in Fig. 2 is also adapted for use in carrier telephone systems in which the carrier is continuously transmitted throughout the system. A system of this general type is described in connection with Fig. 42 of the Colpitts and Blackwell article, supra. In such a system, the carrier currents transmitted in both directions, together with their upper or lower side bands, are amplified in the common amplifier CA, which operates from the relatively low incoming level, and can therefore be of relatively small load capacity. For the second stage of amplification, the directional groups of carrier currents divide, the higher group of frequencies being transmitted through amplifier WA and the lower group of frequencies being transmitted through the amplifier, EA. These two amplifiers operate from the output level of amplifier CA and are of correspondingly greater load capacity.

Fig. 3 shows a modification of the repeater of Fig. 2 in which individual amplifiers are employed for the upper and lower groups of frequencies for the first stage of amplification and a common high power amplifier is employed for the two groups for the second stage of amplification. This repeater is best adapted for use in systems in which the unmodulated carrier component is suppressed. The currents comprised in the upper frequency group incoming over the line section W are transmitted through the high pass input filter HPIF, west to east amplifier WA, high pass grouping filter HPGF, common amplifier CA, high pass output filter HPOF to line section E. The currents comprised in the lower frequency group incoming from line section E pass through the low pass input filter LPIF, the east to west amplifier EA, low pass grouping filter LPGF, common amplifier CA, low pass output filter LPOF to line section W.

The curve of Fig. 4 which was used to illustrate the operating level of the repeater of Fig. 2 is equally applicable to the repeater of Fig. 3. In the case of the repeater of Fig. 3, referring particularly to west to east transmissions, the west to east amplifier WA at repeater point R₀ raises the level of the currents transmitted therethrough from -30 miles to plus 10 miles indicated by the line X, while the common amplifier CA raises the currents transmitted therethrough from a level of plus 10 miles to a level of plus 30 miles, indicated at Y.

In this type of system to which this repeater is particularly suited, as has been explained in detail above, the carrier and one side band is suppressed and only the relatively small upper or lower side bands are transmitted. For this reason there is only a very small load on the amplifiers WA and EA, this load at no time being greater than the total number of one-way channels since, as pointed out above, the operators at the ends of a circuit do not talk simultaneously. The common amplifier CA is designed to operate at a higher level than the amplifiers WA and EA, the input currents applied to this common amplifier being at a level of plus 10 miles, and the gain introduced by the amplifier raising the level of these currents to plus 30 miles.

Aside from the economical advantages of the invention, it will be seen that the total amplification and total filter discrimination of the repeaters of Figs. 2 and 3 are broken up into successive alternate gains and losses, so that the absolute gain or loss in any one unit is smaller than required in the usual repeater arrangement in which a single amplifier and two filters are employed in each direction.

The invention set forth herein is, of course, susceptible of various other modifications and adaptations. The figures given herein are also to be taken as merely illustrative of the invention and are not to be considered as limiting its scope in any way.

What is claimed is:

1. In a two-way repeater for wave transmission systems comprising line sections for two-way transmission in which the waves transmitted in opposite directions are comprised in different frequency groups, a one-way selective path interconnecting said line sections for one of said frequency groups, another one-way selective path interconnecting said line sections for the other of said frequency groups, an amplifier common to both said paths, and separate amplifiers in each of said paths.

2. In a two-way repeater for wave transmission systems comprising line sections for two-way transmission in which the waves transmitted in opposite directions are com-

prised in different frequency groups, an input and an output repeater branch, connected to each line section, an amplifier connected between said input and output branches for amplifying waves comprised in both frequency groups, and separate amplifiers for each of said frequency groups in one of said branches.

3. In a two-way repeater for wave transmission systems comprising line sections for two-way transmission in which the waves transmitted in opposite directions are comprised in different frequency groups, an input and an output repeater branch connected to each line section, an amplifier connected between said input and output branches for amplifying waves comprised in both frequency groups, and separate amplifiers for each of said frequency groups in said output branch.

4. In a carrier wave signaling system in which the oppositely directed waves are comprised in different frequency groups, two line sections, a two-way repeater having input and output branches connected to each of said line sections, a common amplifier for all of said waves connected between said branches, grouping filters in each of said branches, and amplifiers in said output branch between the output of said common amplifier and each of said line sections.

5. In a carrier wave signaling system in which the oppositely directed waves are comprised in different frequency groups, two line sections, a two-way repeater having input and output branches connected to each of said line sections, a common amplifier for all of said waves connected between said branches, grouping filters in said input repeater branch, and amplifier units comprising two wave filter sections joined by an amplifier disposed in said output repeater branch between the output of said common amplifier and each of said line sections.

6. A repeater system for through repeating between two two-way transmission lines comprising a pair of oppositely directed one-way transmission branches connected to each line, a common one-way path connected between the incoming and the outgoing branches, a common amplifier in said common path and other amplifiers in certain of said branches, said amplifiers in said branches operating in tandem with the amplifier in the common path and adding their respective amplifications to that of said common amplifier whereby the added gain of each one-way branch over that furnished by the common amplifier is determined by the amplifier individual to the branch.

In witness whereof, we hereunto subscribe our names this 16th day of June A. D., 1924.

JACOB S. JAMMER.
CHARLES W. GREEN.