

O. O. BODVIG.

PNEUMATIC STACKER FOR THRESHING MACHINES.

(Application filed May 13, 1902.)

(No Model.)

2 Sheets—Sheet 1.

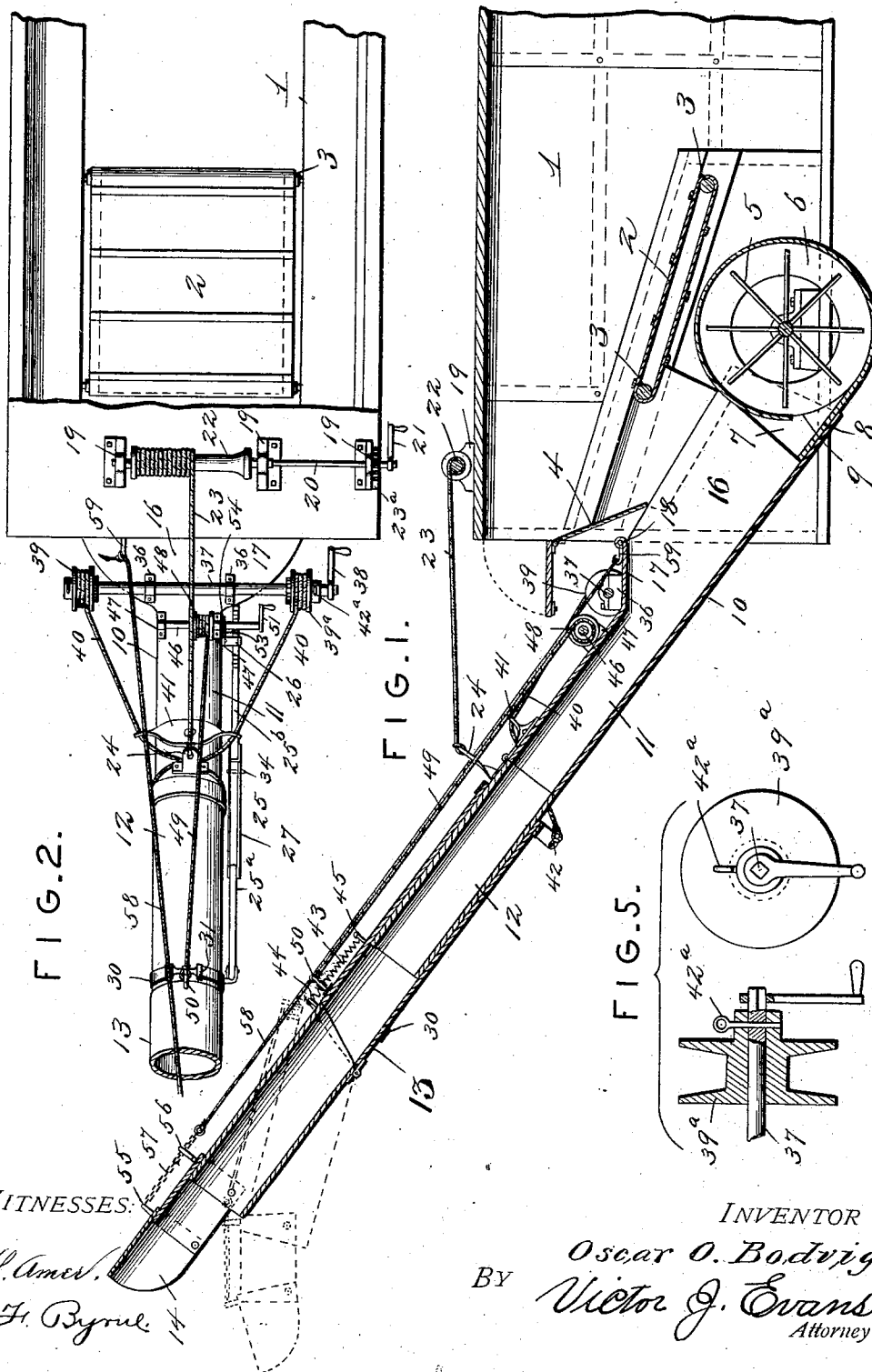

FIG. 2.

FIG. 1.

FIG. 5.

WITNESSES:

H. L. Ames,
J. F. Byrle

INVENTOR

Oscar O. Bodvig.

BY

Victor J. Evans
Attorney

O. O. BODVIG.

PNEUMATIC STACKER FOR THRESHING MACHINES.

(Application filed May 18, 1902.)

(No Model.)

2 Sheets—Sheet 2.

FIG. 3.

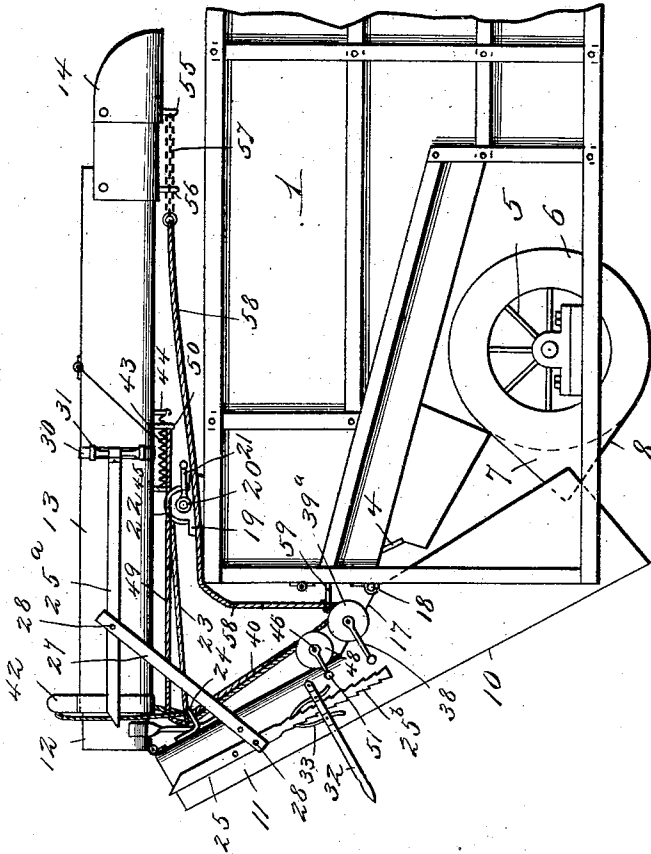
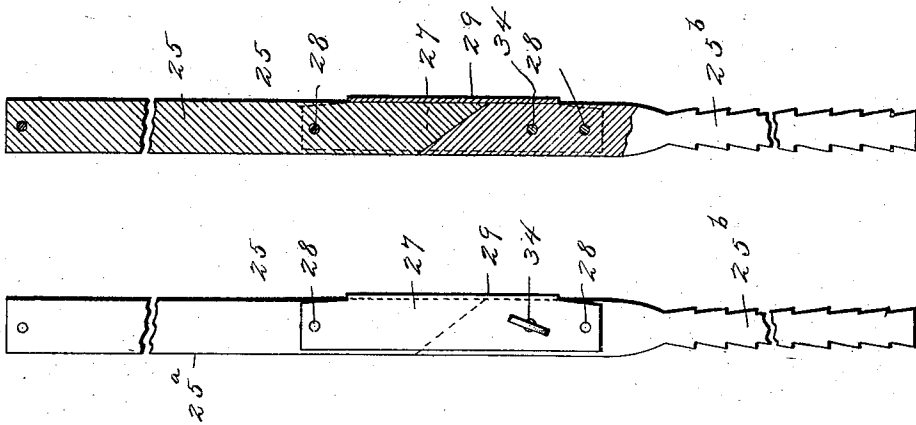

FIG. 4.



WITNESSES:

H. L. Amer.
J. F. Byrnl.

INVENTOR

Oscar O. Bodvig

BY

Victor J. Evans
Attorney

UNITED STATES PATENT OFFICE.

OSCAR O. BODVIG, OF VELVA, NORTH DAKOTA.

PNEUMATIC STACKER FOR THRESHING-MACHINES.

SPECIFICATION forming part of Letters Patent No. 712,902, dated November 4, 1902.

Application filed May 13, 1902. Serial No. 107,156. (No model.)

To all whom it may concern:

Be it known that I, OSCAR O. BODVIG, a citizen of the United States, residing at Velva, in the county of McHenry and State of North Dakota, have invented new and useful Improvements in Pneumatic Stackers for Threshing-Machines, of which the following is a specification.

This invention relates to pneumatic stackers for threshing-machines; and its primary object is to provide a stacker in which the several sections constituting the same are provided with new and improved means for rendering them capable of ready adjustment to direct the chaff or straw at any point found advantageous.

Another object of the invention is to provide new and improved means for adjusting the several sections independently of each other and hold them in their adjusted position.

The invention consists of the construction, combination, and arrangement of parts to be hereinafter fully described and claimed.

In the drawings, Figure 1 is a central longitudinal sectional view of the rear end of a threshing-machine and a stacker constructed in accordance with my invention, showing in dotted lines the position the forward portion of the stacker may be caused to assume. Fig. 2 is a top plan view thereof, the forward portion of the stacker being broken away. Fig. 3 is a side elevation thereof, illustrating the position the stacker assumes when the same is in an inoperative position. Fig. 4 is a side elevation and a vertical longitudinal section of the adjusting-rod. Fig. 5 is a central sectional and an end elevation of one of the pulleys.

Similar numerals of reference are employed to indicate corresponding parts in the several views.

1 designates the rear end of a threshing-machine, having mounted therein in the usual manner a straw or chaff carrier 2, comprising an endless slatted belt suitably mounted upon rollers 3 and which is adapted to carry the chaff against a deflecting-board 4, from which it is directed to the path of the air-current generated by a fan 5. The fan 5 is journaled below the carrier 2 and provided with a suitable housing 6, having forwardly-extending side and bottom flanges 7 and 8, respectively,

and an opening 9 at a point between the flanges to direct the air-current through a stacker 10. The stacker 10 comprises several sections—a lower section 11, an intermediate section 12, and an upper section 13, having hinged thereto a sectional hood 14. The lower end of the section 11 terminates in an enlarged portion producing a wind-trunk 16, having a horizontally-disposed portion 17, provided with barrels for the reception of a pin-tle 18, carried by the threshing-machine, thereby connecting the stacker to the thresher to have a vertical movement thereon and to place the lower end of the wind-trunk in proper position with relation to the fan. The lower end and upper side of the wind-trunk are open for the reception of the contiguous portion of the fan-casing and to permit the chaff or straw to be directed through the medium of the deflecting-board in the path of the wind-current to be blown through the stacker. The section 11 has hinged to its forward end the section 12, permitting the stacker to be bent upon itself to place the forward portion thereof upon the top of the thresher when the stacker is out of operation.

Situated upon the thresher at a convenient point are bearings 19, having journaled therein a shaft 20, one end thereof being provided with a crank 21, and mounted upon the shaft to turn therewith is a spool 22, having secured thereto one end of a cable 23, the opposite end thereof being fastened to an eye 24 upon the section 12. It will be perceived that when the spool is caused to rotate through the medium of the crank 21 the cable is wound upon the spool, turning the stacker upon its hinge to render the same inoperative and reduce it to compact form, in which condition the forward end of the stacker will assume the position upon the top of the threshing-machine indicated in Fig. 3 of the drawings, and to hold the stacker in such position a dog 23^a is adapted to engage a ratchet-wheel carried by the shaft 20.

The section 13 is mounted upon the section 12 to be revolved or telescoped longitudinally thereon to increase the length of the stacker or to change the position of the discharge end thereof to direct the chaff or straw upon any point of the stack. The section 13 is moved longitudinally through the medium of an adjusting-rod 25, having one end secured to the

section 13 and the other end slidably mounted in a bracket 26 upon the section 12. The rod 25 comprises members 25^a and 25^b, having their contiguous ends oppositely beveled and connected by an inverted-U-shaped link 27, adapted to straddle the members and connected thereto by pivot-pins 28. The connecting-plate 29 of the link 27 is broken away adjacent its ends to permit the members to freely turn upon their pivots to follow the movements of the forward portion and section 11 of the stacker. The forward end of the member 25^a is rigidly connected to a collar 30, loosely mounted upon the section 13 to permit the same to revolve upon the section 12, and in order to prevent the collar 30 from having a longitudinal movement it is secured in place by guide-loops 31, carried by the section 13. A lever 32 is mounted upon the bracket 26 and provided with a pair of spring-pressed pawls 33, adapted to engage the serrated edges of the member 25^b, and when the lever is oscillated the pawls will alternately engage the serrations and move the section 13 forward, and when the pawls are disengaged from in contact with the serrations the section 13 is free to be moved backward. The oppositely-beveled ends of the adjusting-rod will limit the downward movement of the members, in which position they are held by a headed bolt 34, passing through one of the members and engaging the flanges of the link 27.

The advantages of the above manner of connecting the sections 12 and 13 may be stated as follows: The section 13 may be moved longitudinally upon the section 12 by the oscillation of the lever 32. The forward section of the stacker may be turned upon its hinge to place the same upon the top of the thresher by withdrawing the bolt 34, which permits the members of the adjusting-rod to freely turn upon their pivots to accommodate themselves to the different positions the sections of the stacker assume when the same is thrown out of operation. The sections 11 and 12 of the stacker are held in rigid relation when the stacker is in operative position by inserting the bolt 34 in proper place, and the section 13 is free to be turned by the collar 30, being loosely mounted upon the section 13.

Situated upon the horizontally-disposed portion 16 of the wind-trunk are bearings 36, having journaled therein a shaft 37, provided upon one of its ends with a crank 38 and also carrying pulleys 39 and 39^a, having oppositely wound thereon the ends of cables 40, their free ends after being passed through the eyes of a guide 41 being crossed and secured to depending ears of a collar 42, carried by the section 13. The pulley 39^a is loosely mounted upon the shaft 37 and has a laterally-extending flange carrying a spring-pressed locking-pin 42^a engaging the shaft 37 to normally hold the pulley 39^a in rigid relation thereto. The turning of the shaft 37 in one direction will cause the pulleys 39 and 39^a to rotate in

the same direction, winding one of the cables and unwinding the other, thereby causing the section 13 to revolve upon the section 12, placing the discharge end of the conveyer in a position to discharge the chaff or straw upon different portions of the stack. In moving the section 13 longitudinally the pin 42^a is removed from in engagement with the shaft 37 to permit the pulley 39^a to revolve independently of the shaft 37, allowing the cables to be unwound from the pulleys to follow the movement of the section 13, thereby accommodating for the oppositely winding of the cables upon the pulleys.

The section 13 comprises two portions hinged together to permit the forward portion thereof to be tilted, as indicated in dotted lines in Fig. 1 of the drawings, and in order to limit the downward movement of the forward portion of the section 13 a spring 43 is employed, having its ends secured to eyes 44 and 45, carried by the sections 13 upon opposite sides of the joint. A shaft 46, journaled in bearings 47, mounted upon the section 11, carries a pulley 48, having secured thereto one end of a cable 49, the opposite end thereof being fastened to an eye 50 upon the hinged portion of the section 13. The turning of the shaft 46 in one direction by means of a crank 51 will cause the cable to be wound upon the pulley 48, returning the hinged portion of the section 13 to its normal position, where it may be held by a dog 53, engaging a ratchet-wheel 54, carried by the shaft 46. The releasing of the shaft 46 will permit said hinged portion to tilt downward by its own weight to the limit of the expansion of the spring 43, and the angle of inclination of the hinged portion may be limited through the medium of the cable 49 and shaft 46, as is obvious.

The hood 14 comprises a plurality of sections hinged together, each section being provided with eyes 55 and 56. The eye 55 has attached thereto one end of a chain 57, passing through the eye 56, which serves as a guide, and the opposite end thereof has attached thereto a cable 58, having its free end suitably knotted to engage a hook 59, carried by the thresher. The hood 14 may be adjusted through the medium of the cable 58 and held in its adjusted position by one of the knots engaging the hook 59.

It is obvious from the above description, taken in connection with the accompanying drawings, that a pneumatic stacker is provided which is cheap, durable, and effective and which will accomplish the desired results.

Having described the invention, what is claimed as new is—

1. The combination with a threshing-machine, of a pneumatic stacker mounted thereon and comprising a plurality of sections, one of which is capable of being revolved and moved longitudinally, the movable section having its forward portion hinged to swing in a vertical plane, a spring for controlling

said hinged portion, means for revolving the section, and means for moving the section longitudinally.

2. The combination with a threshing-machine, of a pneumatic stacker mounted thereon and comprising a plurality of sections, one of which is capable of being revolved and moved longitudinally, means for revolving the section, an adjusting-rod for moving the section longitudinally, and means for connecting the adjusting-rod to the movable section whereby it may be revolved independent of the adjusting-rod.

3. The combination with a threshing-machine, of a pneumatic stacker mounted thereon and comprising a plurality of sections, one of which is capable of being revolved and moved longitudinally, means for revolving the section, a ring loosely mounted upon the movable section, an adjusting-rod having one end secured to the ring and its opposite end slidably secured to the adjacent section, and means for imparting motion to the adjusting-rod.

4. The combination with a threshing-machine, of a pneumatic stacker secured thereto and comprising a plurality of sections one of which is capable of being revolved and moved longitudinally, means for revolving the section, a ring loosely mounted upon the movable section, an adjusting-rod comprising a plurality of members having one end secured to the ring, a bracket carried by the adjacent section to slidably secure the free end of the adjusting-rod to said section, a link for connecting the members, and means for imparting motion to the connecting-rod whereby the movable section is adjusted longitudinally.

5. The combination with a threshing-machine, of a pneumatic stacker secured thereto and comprising a plurality of sections, one of which is capable of being revolved and moved longitudinally, a shaft, pulleys carried by the shaft, cables, each having one of their ends secured to the movable section and their opposite ends secured to the pulleys, whereby the movable section is caused to revolve when motion is imparted to the pulleys, and means for adjusting said section longitudinally.

6. The combination with a threshing-machine, of a pneumatic stacker mounted thereon and comprising a plurality of sections one of which is capable of being revolved and moved longitudinally, a ring carried by the movable section, a guide having eyes and carried by the adjacent section, a shaft, pulleys mounted upon the shaft, cables, each having one of their ends oppositely wound upon the pulleys, then passed through the eyes, crossed, and their opposite ends fastened to the ring whereby, when the pulleys are caused to rotate, the said section is revolved, and means for moving the section longitudinally.

7. The combination with a threshing-machine, of a pneumatic stacker mounted thereon and comprising a plurality of sections, one of which is capable of being revolved and moved longitudinally, a shaft, pulleys mounted upon the shaft, cables, each having one of their ends secured to the movable section and their free ends oppositely wound around the pulleys, whereby, when motion is imparted to the pulleys said section is revolved, means for moving the section longitudinally, and means for permitting one of the pulleys to revolve independently of the other pulley, permitting the cables to unwind from the pulleys to follow the movable section in its longitudinal movement.

8. The combination with a threshing-machine, of a pneumatic stacker secured thereto and comprising a plurality of sections, one of which is capable of being revolved and moved longitudinally, a ring mounted on the movable section, an adjusting-rod comprising hinged members, one of the members being secured to the ring, and the other member provided with serrations and slidably secured to the adjacent sections, a lever, pawls carried by the lever and adapted to engage the serrations, and means for revolving said section.

9. A pneumatic straw-stacker comprising a lower section provided with a wind-trunk, an intermediate section hinged to the lower section, an upper section slidably and revolvably mounted upon the intermediate section, and having its forward portion hinged to swing in a vertical plane, a spring for controlling said hinged portion, and a sectional hood mounted upon the discharge end of the stacker.

10. A pneumatic straw-stacker comprising a lower section provided with a wind-trunk, an intermediate section hinged to the lower section, an upper section slidably and revolvably mounted upon the intermediate section, and having its forward portion hinged to swing in a vertical plane, a spring for controlling said hinged portion, a sectional hood mounted upon the discharge end of the stacker, means for revolving the upper section longitudinally.

11. The combination with a threshing-machine, of a pneumatic stacker hinged thereto and comprising a plurality of sections, one of which is capable of being revolved and moved longitudinally, the movable section having its forward portion hinged to swing in a vertical plane, a spring for controlling the hinged portion, means for turning the stacker upon its hinge, means for moving the section longitudinally, and means for revolving the section.

In testimony whereof I affix my signature in presence of two witnesses.

OSCAR O. BODVIG.

Witnesses:

G. N. LINDAHL,
S. A. LARSON.