



- (51) International Patent Classification: *B01L 3/00* (2006.01) *B01L 9/00* (2006.01)
- (21) International Application Number: PCT/US2015/053296
- (22) International Filing Date: 30 September 2015 (30.09.2015)
- (25) Filing Language: English
- (26) Publication Language: English
- (30) Priority Data: 62/057,575 30 September 2014 (30.09.2014) US
- (71) Applicant: **EXOSOME DIAGNOSTICS, INC.** [US/US]; 840 Memorial Drive, Cambridge, Massachusetts 02139 (US).
- (72) Inventors: **SKOG, Johan**; 250 First Avenue, Apt 703, Charlestown, Massachusetts 02129 (US). **TISEL, Bill**; 2940 Autumn Woods Drive, Chaska, Minnesota 55318 (US). **BAKER, Joseph**; 2893 Alta Vista Dr., Fallbrook, California 92028 (US).
- (74) Agent: **HOPKINS, Brian P.**; Cooley LLP, 1299 Pennsylvania Avenue, NW, Suite 700, Attn: Patent Group, Washington, District of Columbia 20004 (US).
- (81) Designated States (*unless otherwise indicated, for every kind of national protection available*): AE, AG, AL, AM, AO, AT, AU, AZ, BA, BB, BG, BH, BN, BR, BW, BY, BZ, CA, CH, CL, CN, CO, CR, CU, CZ, DE, DK, DM, DO, DZ, EC, EE, EG, ES, FI, GB, GD, GE, GH, GM, GT, HN, HR, HU, ID, IL, IN, IR, IS, JP, KE, KG, KN, KP, KR, KZ, LA, LC, LK, LR, LS, LU, LY, MA, MD, ME, MG, MK, MN, MW, MX, MY, MZ, NA, NG, NI, NO, NZ, OM, PA, PE, PG, PH, PL, PT, QA, RO, RS, RU, RW, SA, SC, SD, SE, SG, SK, SL, SM, ST, SV, SY, TH, TJ, TM, TN, TR, TT, TZ, UA, UG, US, UZ, VC, VN, ZA, ZM, ZW.
- (84) Designated States (*unless otherwise indicated, for every kind of regional protection available*): ARIPO (BW, GH, GM, KE, LR, LS, MW, MZ, NA, RW, SD, SL, ST, SZ, TZ, UG, ZM, ZW), Eurasian (AM, AZ, BY, KG, KZ, RU, TJ, TM), European (AL, AT, BE, BG, CH, CY, CZ, DE, DK, EE, ES, FI, FR, GB, GR, HR, HU, IE, IS, IT, LT, LU, LV, MC, MK, MT, NL, NO, PL, PT, RO, RS, SE, SI, SK,

[Continued on next page]

(54) Title: APPARATUSES, METHODS, AND SYSTEMS FOR SAMPLE COLLECTION AND DISPERSION

(57) Abstract: In order to address an inability to separate portions of a sample and/or substance, in some embodiments, methods and apparatuses for separating components and/or portions of a sample are provided. For example, a sample collection container may comprise two areas within the container, one which is configured to contain a first volume of the sample, and one which is configured to contain a second volume of the sample. A float device may be configured to seal the portion of the container collecting the first volume from the portion of the container collecting the second volume, after the former portion of the container has been filled. The sample collection container may further comprise a top cap configured to further seal the two portions of the container, and to prevent leakage and/or spilling of the sample from the sample collection container.

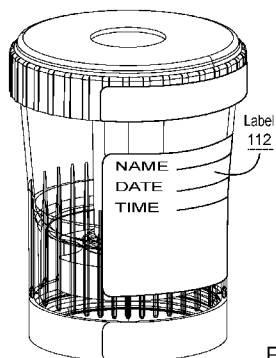
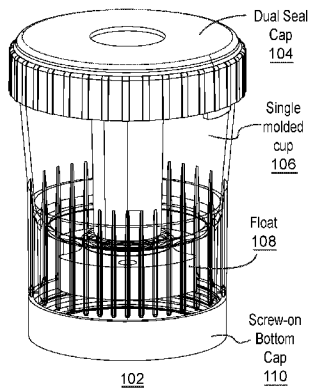

FIGURE 1

WO 2016/054252 A1

SM, TR), OAPI (BF, BJ, CF, CG, CI, CM, GA, GN, GQ, GW, KM, ML, MR, NE, SN, TD, TG). **Published:**

— with international search report (Art. 21(3))

APPARATUSES, METHODS, AND SYSTEMS FOR SAMPLE COLLECTION AND DISPERSION

CROSS REFERENCE TO RELATED APPLICATION

[001] This application claims benefit of and priority to U.S. provisional patent application no. 62/057,575, entitled, "Appartuses, Methods, and Systems for Sample Collection and Dispersion", filed September 30, 2014, the entire disclosure of which is herein incorporated by reference in its entirety.

BACKGROUND

[002] Conventional sample collection containers often collect samples in a single compartment of the container, and do not allow for separation of parts of the sample (e.g., to separate a first volume of the sample from the rest of the sample, to separate components of the sample, and/or the like). However, the first 20-40 mL and/or like quantity of a sample may contain the largest quantity of components of interest in the sample (e.g., for a urine sample, the first 25 mL of urine may contain the greatest concentration of hormones, exosomal RNA prostate cancer markers, and/or the like). Thus, such container designs can dilute the sample and make it difficult for laboratories to test the samples for abnormalities. Merely reducing the size of the container to 25 mL may be both cumbersome to a patient who must supply the sample, and may waste portions of the sample which could be used to test other ailments, e.g., the 26-40mL of a urine sample left after the first volume of the sample may still be optimal for assessment of other illnesses such as bladder cancer and/or other disorders, even if it is not optimal for testing other ailments. Additionally, conventional sample collection containers often need to be shipped long distances in order to be analyzed at a laboratory, and can leak or spill, causing part of the sample to be lost in transit.

SUMMARY OF SOME OF THE EMBODIMENTS

[003] In some embodiments, a biological sample (e.g., a urine sample, and/or the like) may be collected for analysis, e.g., to determine a person's health and/or the like. In some embodiments, a sample collection cup may be configured to separate portions of a sample from other portions of the sample (e.g., a first volume of the sample, and/or the like may be separated from other portions of the sample), in order to obtain optimal results. In some embodiments, parts of the container may

be sealed in a plurality of ways in order to prevent leakage or spills, e.g., during transit and/or the like, and to prevent dilution of the portions of the sample.

[004] In some embodiments, a plurality of designs may be utilized in order to easily collect and separate portions of a sample for optimal extraction, including a two-cup container, a bottom-cap container, and/or the like, using a float to separate a first volume of fluid from the second volume of fluid.

BRIEF DESCRIPTION OF THE FIGURES

[005] **FIGURE 1** shows a bottom-cap design for a sample collection container, according to some embodiments.

[006] **FIGURE 2** shows a bottom-cap design for a sample collection container, according to some embodiments.

[007] **FIGURE 3** shows volume markings for a sample collection container, according to some embodiments.

[008] **FIGURE 4** shows a top cap for a sample collection container, according to some embodiments.

[009] **FIGURE 5** shows a float design for a sample collection container, according to some embodiments.

[0010] **FIGURE 6** shows a float design for a sample collection container, according to some embodiments.

[0011] **FIGURE 7** shows a bottom cap design for a sample collection container, according to some embodiments.

[0012] **FIGURE 8** shows filling a sample collection container, according to some embodiments.

[0013] **FIGURE 9** shows a cap seal design for a sample collection container, according to some embodiments.

[0014] **FIGURE 10** shows a cap seal design for a sample collection container, according to some embodiments.

[0015] **FIGURE 11** shows a cap seal design for a sample collection container, according to some embodiments.

[0016] **FIGURE 12** shows extracting samples from a sample collection container, according to some embodiments.

[0017] **FIGURE 13** shows volume areas in a sample collection container, according to some embodiments.

[0018] **FIGURE 14** shows a two-cup design for a sample collection container, according to some embodiments.

[0019] **FIGURE 15** shows a two-cap design for a sample collection container, according to some embodiments.

[0020] **FIGURE 16** shows an assembled two-cap design for a sample collection container, according to some embodiments.

[0021] **FIGURE 17** shows a seal design for a sample collection container, according to some embodiments.

[0022] **FIGURE 18** shows a cap seal design for a sample collection container, according to some embodiments.

[0023] **FIGURE 19** shows seal area thickness for a sample collection container, according to some embodiments.

[0024] **FIGURE 20** shows designs for a sample collection container, according to some embodiments.

DETAILED DESCRIPTION OF SOME OF THE EMBODIMENTS

[0025] In some embodiments, sample collection containers may be formed via a bottom-cap design, a two-cup design, and/or the like. Referring to **FIGURE 1**, in some embodiments, a laboratory may use a bottom-cap design **102** for the sample collection container. In some embodiments, the container may comprise a dual-seal top cap **104**, a single molded collection cup **106**, a float device **108**, and a screw-on bottom cap **110**. In some embodiments, the collection container may also have room for a label **112** on which sample identification information (e.g., the name of the patient, the date and time the sample was obtained, the type of sample obtained, and/or the like) may be imprinted. In some embodiments, referring to **FIGURE 2**, an exemplary sample collection container may include a dual-start thread at the top of the container **202**, e.g., for easy removal and placement of the top lid by a patient. The bottom cap **206** may be placed on the sample collection container on a single-start thread. The container may further comprise ribs on the sides of the container **204**, e.g., to help a patient grip the container. Each section of the container may have a sealing rib **208**, which may help seal the portion of the container and prevent spills (e.g., sealing rib **208** may prevent the sample from spilling out of the top lid, and sealing rib **210** may prevent the sample in the second volume from contaminating the sample collected in the first volume, and/or the like). Referring to **FIGURE 3**, in some embodiments, the container may also comprise volumetric markings **302** and company logos **304**, and/or like information.

[0026] **FIGURE 4** shows a top cap for a sample collection container, according to some embodiments. For example, in some embodiments, a top cap **402** may comprise a screw cap with grip ridges, and a cap stop **404**, e.g., to secure the cap and prevent the cap from turning too much in a particular direction. The cap may further comprise a long protrusion from the screw cap component, which may connect with the opening of the first volume of the container, and/or the like. In some embodiments, the cap may comprise at least two seals. For example, the cap may comprise a first volume seal **406** which may seal the opening of the first seal via connecting with sealing rib **210** in order to prevent leaking between the first and second volumes. The cap may further comprise a second volume seal **408** between the cap and the top of the container. In some embodiments, the second volume seal and the cap may comprise round threads.

[0027] **FIGURES 5 and 6** show float designs for a sample collection container, according to some embodiments. In some embodiments, a float **502** may be a device and/or mechanism for preventing fluid flow between a first and second volume of the collection container when the first volume has filled, and may allow for extraction of the sample from the bottom cap with minimized contamination of the sample. In some embodiments the float may also prevent fluid from flowing into the first volume after the first volume has been filled. For example, in some embodiments, a float may comprise food grade PE foam with a density of 2.0lb/cu. ft, and may have a thickness of 0.375 inches. In some embodiments, a float may have fluid pass-through holes **506** through which the sample may flow through until the first volume area has been filled, and/or fluid access cutouts **504** that laboratories may use to extract sample from the first volume (e.g., via a syringe and/or the like). The access cutouts and holes may be spaced such that the channel between the first and second volumes connects with the solid portion of the float when the container is filled, and such that the cutouts and holes cannot be aligned with the channel and allow sample in the second volume to contaminate the sample in the second volume. In some embodiments, a float **602** may not comprise any fluid access cutouts, and may instead comprise only pass-through holes **604**, and/or the like. In some embodiments, after the top cap has sealed the first volume from the second volume, the container may be inverted, allowing the float to float towards the bottom cap of the container **508**. Thus by inverting the container, a laboratory device and/or the like may be able to extract sample from the first volume via the holes and/or cutouts in the float.

[0028] **FIGURE 7** shows a bottom cap design for a sample collection container, according to some embodiments. In some embodiments, the bottom cap **702** may have a 53-400 cap and single thread specification, and may be made out of polypropylene. The cap may comprise a core liner **704** comprising a layer of LDPE film, a layer of PE foam, and a layer of LDPE film, and/or a like composition). The bottom cap may sit flush to the rib bottoms on the container **706**, and may maintain the outer diameter of the ribs. The seal on the bottom cap may create a container seal

by compressing a flexible polyethylene membrane on the inside of the cap, and/or a similar mechanism.

[0029] FIGURE 8 shows filling a sample collection container, according to some embodiments. In some embodiments, a patient may be able to start filling the cup with their sample (e.g., a urine sample), which may first collect in a dead volume area above the first volume chamber (e.g., the lower volume chamber) **802**. In some embodiments, the dead volume area may be able to hold 0.8mL of sample, and/or the like. In some embodiments, there may not be a dead volume area, and the sample may immediately start to collect in the lower volume chamber. As the lower chamber fills with sample **804**, the float may be able to rise, eventually being able to close off the lower chamber from the upper chamber. In some embodiments the lower volume chamber may be able to hold a volume (e.g., 20-25mL, and/or any volume from, for example, 5mL-40 mL, and/or the like) of sample, and/or a like amount. After the lower chamber has been filled, the upper chamber may still be filled **806**; in some embodiments, the upper chamber may be able to hold 95 mL of sample, and/or a like amount. After the sample cup has been filled (e.g., at the top volumetric line on the container, and/or the like), the top cap may be placed on the container **808**. The top cap may displace some volume of the sample as it closes (e.g., the cap may displace approximately 15 mL of the sample, causing the fluid in the container to raise 0.17 inches, and/or the like).

[0030] FIGURE 9 shows a top cap seal design for a sample collection container, according to some embodiments. For example, the top cap may comprise a lower seal **904** which may seal the lower volume chamber from the upper volume chamber. In some embodiments, the bottom seal may start engagement with the sealing rib of the first volume **906** before the top seal has been engaged **908**. In some embodiments, this may start at 0.06 inches from the end of the travel. The top seal **902** may seal the top of the sample collection container, and may start to engage at the end of the travel at the top of the container **910**, e.g., at 0.03 inches from the end of the travel, and/or the like. The cap may be rotated along the thread of the container until the cap stop on the top cap connects with a clasp **912** on the container, preventing further rotation and securing the top cap in place. In some embodiments, the lower and upper volumes of the sample may be pressurized to exemplary pressures of 0.82PSIG and 1.1PSIG, respectively, when the top cap is fully closed on the container. Referring to **FIGURE 10**, the top cap may fit snugly along the thread of the top portion of the container **1002**. The top seal may have a nominal interference of approximately 0.008 inches **1004**, and the bottom seal may have a nominal interference of 0.010 inches **1006**. Referring to **FIGURE 11**, the top seal may vary in its thickness due to interference by the container, e.g., by a factor of +/- 0.003 inches, or may vary in depth, e.g., by a factor of +/- 0.020 inches. Thus, for example, the thickness of the top seal could be 0.003 inches and the depth 0.011 inches **1102** or the

thickness could be -0.003 inches with a depth of 0.005 inches **1104**. In some embodiments, 0.014 inches of interference may be greater than nominal, and 0.002 inches of interference may be below nominal. Similarly, the bottom seal may also vary in thickness due to interference, e.g., by a factor of +/- 0.003 inches, or may vary in depth, e.g., by a factor of +/- 0.020 inches. Thus, the thickness of the bottom seal could be 0.005 inches with a depth of 0.011 inches **1106** or could have a thickness of -0.001 inches with a depth of 0.003 inches **1108**.

[0031] **FIGURE 12** shows extracting samples from a sample collection container, according to some embodiments. The container may be inverted **1202** such that the bottom cap is facing upward, and the bottom cap may be removed from the container. The sample in the lower volume chamber may be removed **1204**, e.g., using the fluid access cutouts and/or the pass-through holes in the float. As more of the sample is removed, the float may move to the bottom of the chamber **1206**. Referring to **FIGURE 13**, the container may have dead volume areas in both the top and bottom chambers of the container **1302**, e.g., of 0.77 mL below the sealing rim in the upper volume, and of 1.72 mL at the top of the lower volume. The upper and lower volumes may contain 95 mL and 25 mL of sample, respectively **1304**.

[0032] **FIGURE 14** shows a two-cup design for a sample collection container, according to some embodiments. A two-cup design may include an upper (e.g., inner) collection cup container **1404a** and a lower (e.g., outer) collection cup container **1404b**, with no bottom cap. In some embodiments, the a two-cup design for a collection container may hae a diameter of 2.6 inches and a height of 3.3 inches, and/or like dimensions. The the top of the container may be closed with a dual-seal cap **1402**, and a float device **1406** in the lower collection cup container. In some embodiments, a seal **1408** may be used for sealing a syringe access hole in the lower collection cup. The seal may be foil, plastic, and/or a plurality of other materials. In some embodiments the outer surface of the collection container may not comprise any ribs, and may be smooth. Referring to **FIGURE 15**, the upper collection cup container **1502** may be detachable from the lower collection cup container **1508**, and may have weld features **1504** which allow for the two cups to fit on top of each other. The lower collection cup may also have a float retaining mechanism **1506** designed to limit the movement of a float in the lower collection cup. In some embodiments, the two cups may stack on top of each other **1510** and may lock into place in order to secure the cups together. The collection container components may be made of food grade polypropylene, and may have a thickness of approximately 0.06 inches. Referring to **FIGURE 16**, the seal **1602** may be peelable from the bottom of the lower collection cup, e.g., in order to access the volume of the sample contained in the lower collection cup. The float **1604** may be able to move in the lower collection cup based on the volume of the sample contained in the lower collection cup, and/or may also have its movement limited by a float stop and/or retaining mechanism. Referring to

FIGURE 17, in some embodiments, the seal may comprise a push tab **1702** that the user may use to open and peel the seal from the lower collection cup.

[0033] **FIGURE 18** shows a cap seal design for a sample collection container, according to some embodiments. In some embodiments, the top cap **1802** may comprise both a screw cap component and a protrusion from the screw cap component which may seal off a hole between the upper collection cup and the lower collection cup. The screw cap may comprise a top seal **1804** which may seal the top of the sample collection container, and a bottom seal **1806** which may seal the upper collection cup from the lower collection cup (e.g., to prevent dilution of the sample in the lower collection cup, and/or the like), e.g., by fitting together with an inner and outer boss surrounding a gap area between the upper collection cup and the lower collection cup. The bottom seal may comprise a rubber seal (e.g., an O-ring and/or like device which may grip the ID of the boss of the upper collection cup). and/or stopper in order to help strengthen the seal between the collection cups. Referring to **FIGURE 19**, the bottom seal may be formed such that there is either a 0.001 inch deflection at 20 pounds **1902**, or an 0.003 inch deflection at 20 pounds **1904**, e.g., depending on the thickness of the protrusion affecting the bottom seal, and/or the like.

[0034] **FIGURE 20** shows designs for a sample collection container, according to some embodiments. For example, a sample collection container may comprise a single container with a cap on the bottom of the container **2002**, a single container with a seal (e.g., a foil seal, and/or the like) which can be peeled off and/or punctured **2004**, a container with a removeable cup on the bottom of the container **2006**, and/or a container with a luer (e.g., a luer on the bottom of a bottom cap **2008**, a luer on the bottom of the protrusion sealing off the lower volume of the collection container from the upper volume **2010**, a luer on the side of a bottom cap **2012**, and/or the like).

[0035] Any and all references to publications or other documents, including but not limited to, patents, patent applications, articles, webpages, books, etc., presented in the present application, are herein incorporated by reference in their entirety, except insofar as the subject matter may conflict with that of the embodiments of the present disclosure (in which case what is present herein shall prevail). The referenced items are provided solely for their disclosure prior to the filing date of the present application. Nothing herein is to be construed as an admission that any invention disclosed herein is not entitled to antedate such material by virtue of prior invention.

[0036] Although example embodiments of the apparatuses, methods and systems have been described herein, other modifications to such embodiments are possible. These embodiments have been described for illustrative purposes only and are not limiting. Other embodiments are possible and are covered by the disclosure, which will be apparent from the teachings contained herein.

Thus, the breadth and scope of the disclosure should not be limited by any of the above-described embodiments but should be defined only in accordance with claims supported by the present disclosure and their equivalents. In addition, any logic flow depicted in the above disclosure and/or accompanying figures may not require the particular order shown, or sequential order, to achieve desirable results. Moreover, embodiments of the subject disclosure may include methods, systems and devices which may further include any and all elements from any other disclosed methods, systems, and devices, including any and all elements corresponding to the collection of biological fluids. In other words, elements from one and/or another disclosed embodiment may be interchangeable with elements from other disclosed embodiments. In addition, one or more features/elements of disclosed embodiments may be removed and still result in patentable subject matter (and thus, resulting in yet more embodiments of the subject disclosure). Still further, some embodiments of the present disclosure may be distinguishable from the prior art for expressly not requiring one and/or another feature disclosed in the prior art (e.g., some embodiments may include negative limitations). Some of the embodiments disclosed herein are within the scope of at least some of the following exemplary claims of the numerous claims which are supported by the present disclosure which may be presented.

What is currently claimed is:

1. A sample collection container apparatus, comprising:
 - a first volume area of a sample collection container, the first volume area configured to contain a first volume of a sample;
 - a float device configured to seal the first volume area after the first volume area has been filled with the first volume of the sample;
 - a second volume area of the sample collection container being configured to contain a second volume of the sample after the first volume area of the sample collection container has been filled;
 - a top cap configured to seal the first volume area of the sample collection container from the second volume area of the sample collection container; and
 - a bottom cap removable from the sample collection container and configured to allow extraction of the first volume of the sample from the first volume area of the sample collection container.
2. The apparatus of claim 1, wherein the sample is introduced to the second volume area, and wherein the second volume area is configured to allow the first volume of the sample to flow into the first volume area.
3. The apparatus of claim 1, wherein the first volume of the sample is a first portion of the sample.
4. The apparatus of claim 3, wherein the first portion of the sample is approximately the first 25 mL of the sample.
5. The apparatus of claim 1, wherein the sample is introduced to the second volume area, and wherein the second volume area is configured to allow the sample to flow into the first volume area.
6. The apparatus of claim 5, wherein the float device is configured to prevent the sample from flowing into the first volume area when the first volume area is filled with the first volume of the sample.
7. The apparatus of claim 1, wherein the second volume of the sample is approximately 95 mL.

8. The apparatus of claim 1, wherein the float includes fluid access cutouts configured to allow a sample extraction device to access the first volume of the sample.
9. The apparatus of claim 8, wherein the sample extraction device is a syringe.
10. A sample collection container apparatus, comprising:
 - a lower collection cup of a sample collection container, the lower collection cup configured to collect a first volume of a sample;
 - a float device configured to seal the lower collection cup of the sample collection container when the lower collection cup has been filled with the first volume of the sample;
 - an upper collection cup of the sample collection container configured to be attachable to the lower collection cup, the upper collection cup of the sample collection container configured to collect a second volume of the sample; and
 - a top cap configured to seal the first volume area of the sample collection container from the second volume area of the sample collection container.
11. The apparatus of claim 10, wherein the sample is introduced to the upper collection cup, and wherein the upper collection cup is configured to allow the first volume of the sample to flow into the lower collection cup.
12. The apparatus of claim 10, wherein the first volume of the sample is a first portion of the sample.
13. The apparatus of claim 12, wherein the first portion of the sample is approximately the first 25 mL of the sample.
14. The apparatus of claim 10, wherein the sample is introduced to the upper collection cup, and wherein the upper collection cup is configured to allow the sample to flow into the lower collection cup.
15. The apparatus of claim 14, wherein the float device is configured to prevent the sample from flowing into the lower collection cup when the lower collection cup is filled with the first volume of the sample.

16. The apparatus of claim 10, wherein the second volume of the sample is approximately 95 mL.
17. The apparatus of claim 10, wherein the float includes fluid access cutouts configured to allow a sample extraction device to access the first volume of the sample.
18. The apparatus of claim 17, wherein the sample extraction device is a syringe.
19. The apparatus of claim 10, wherein the bottom of the lower collection cup is sealed via a peelable seal.
20. The apparatus of claim 19, wherein the peelable seal is a push-tab foil peelable seal.
21. A method for separating portions of a sample, comprising:
 - receiving a sample into a first area of a sample collection container;
 - collecting a first portion of the sample in a second area of the sample collection container;
 - sealing the second area of the sample collection container via a float device when the second area of the sample collection container has collected the first portion of the sample; and
 - collecting a second portion of the sample in the first area of the sample collection container.
22. The method of claim 1, wherein the sample is a urine sample.
23. The method of claim 1, wherein the sample collection container includes a gap between the first area of the sample collection container and the second area of the sample collection container, such that the sample can flow from the first area of the sample collection container to the second area of the sample collection container.

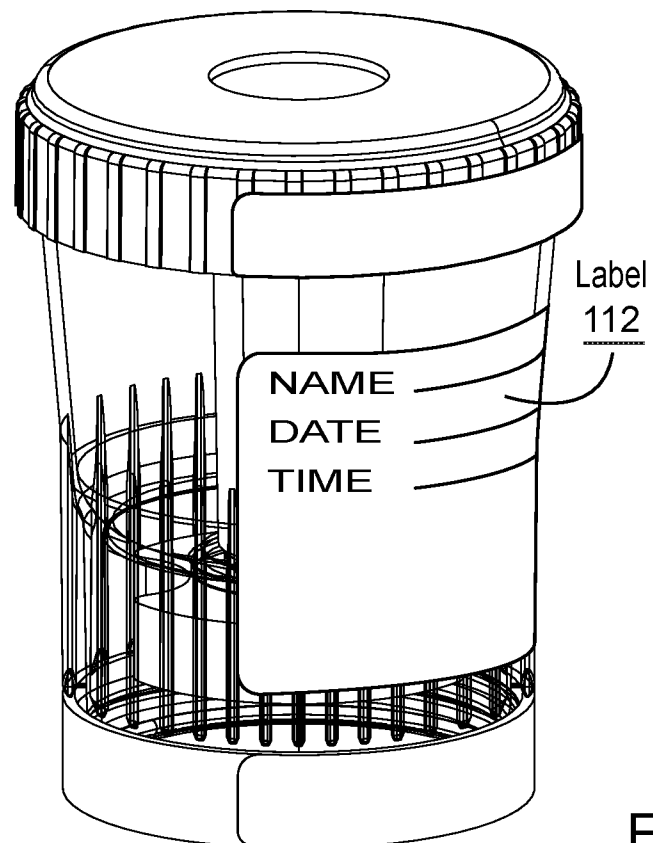
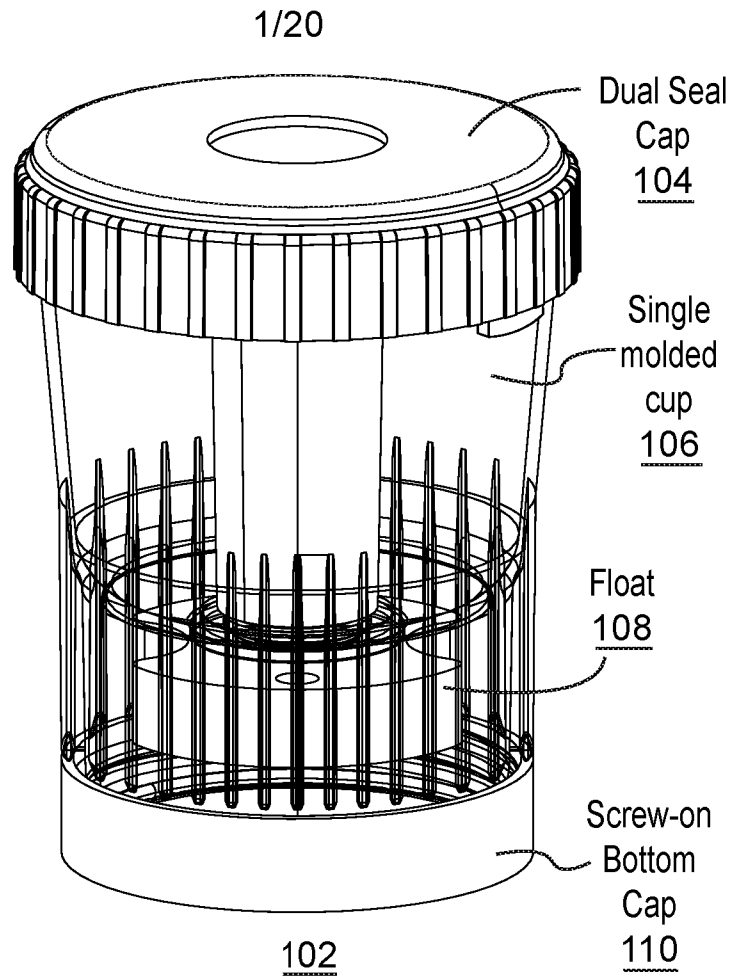

FIGURE 1

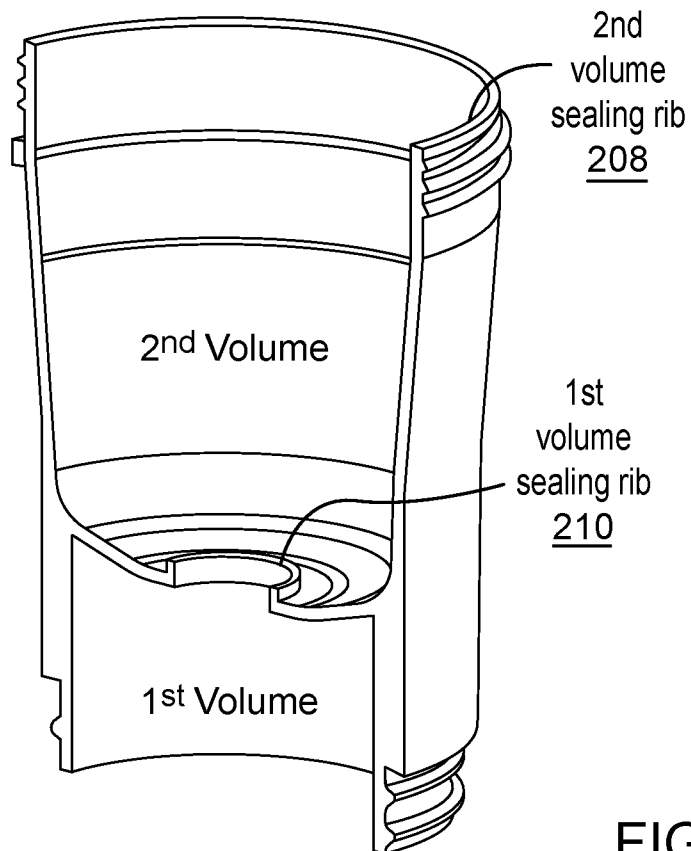
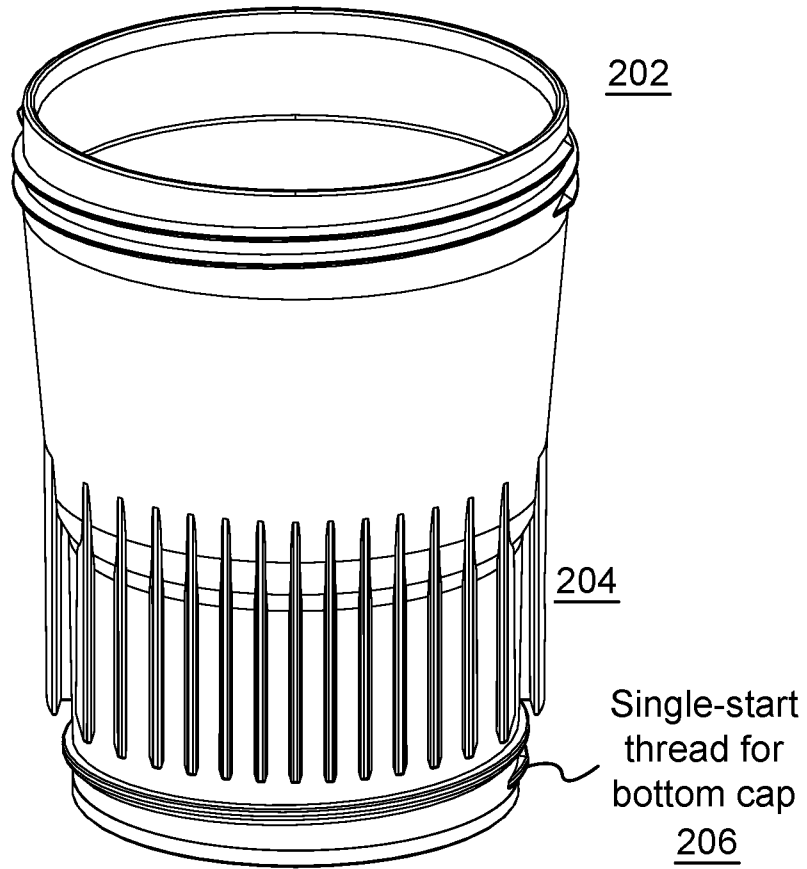

FIGURE 2

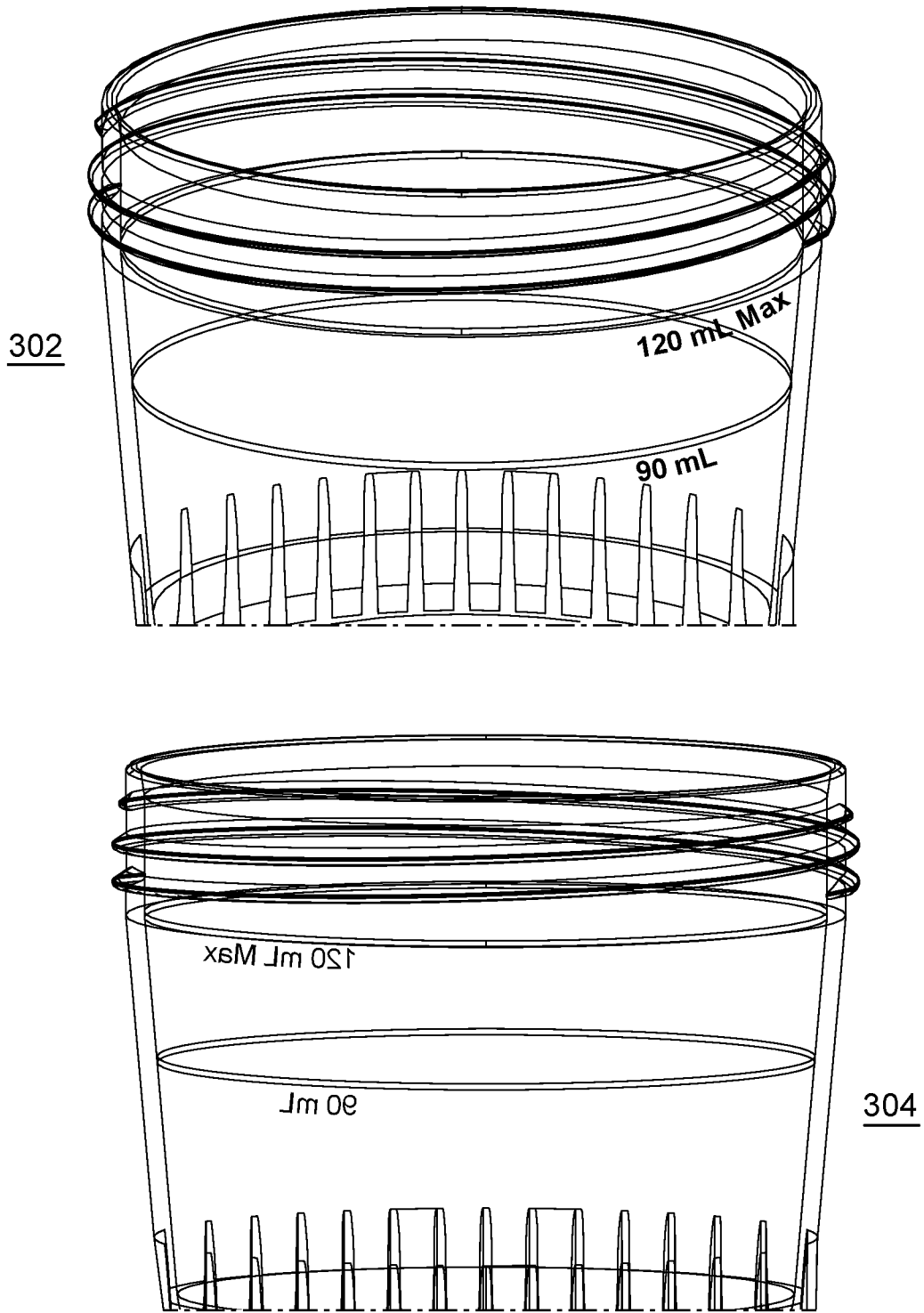

FIGURE 3

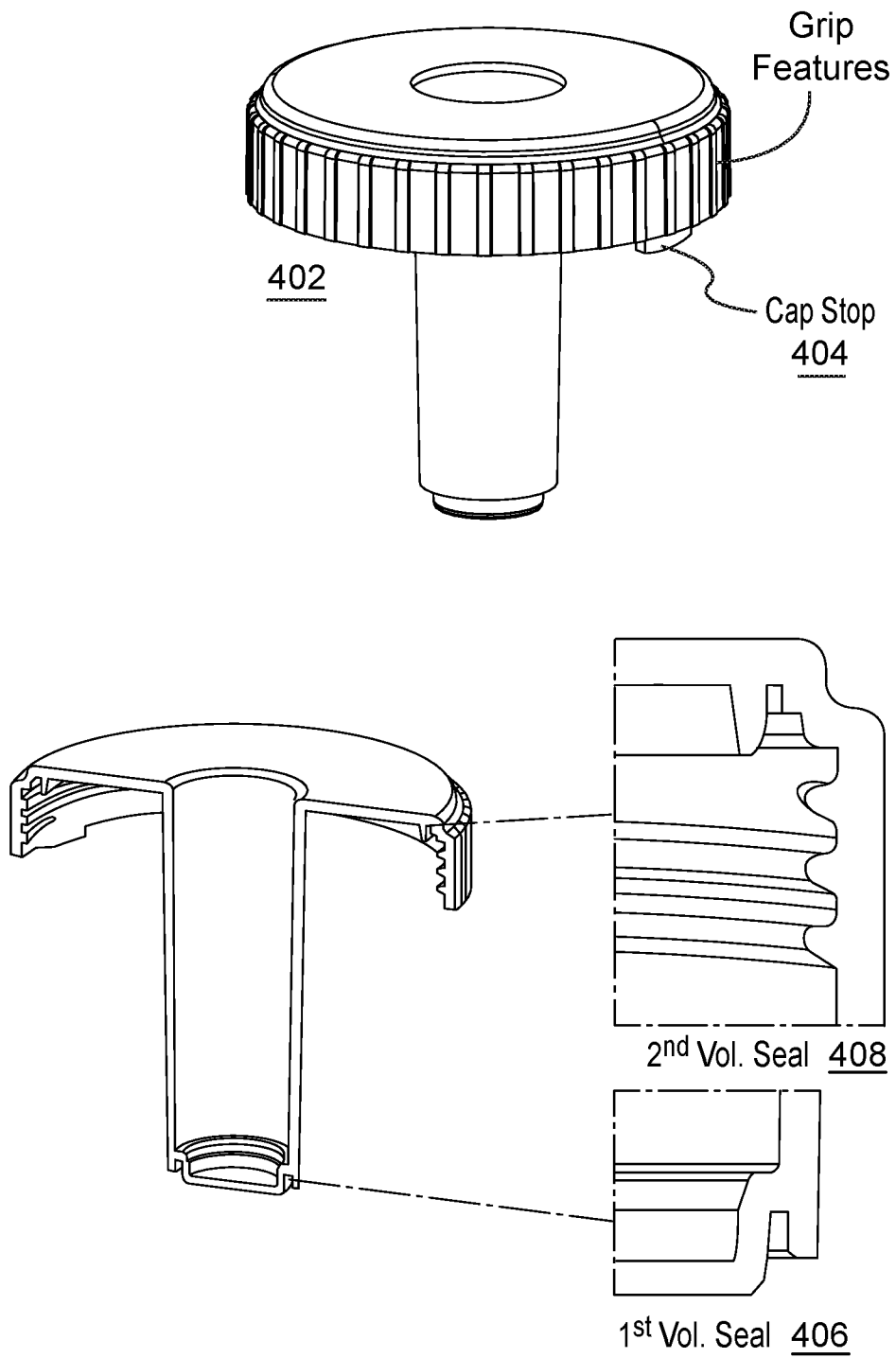

FIGURE 4

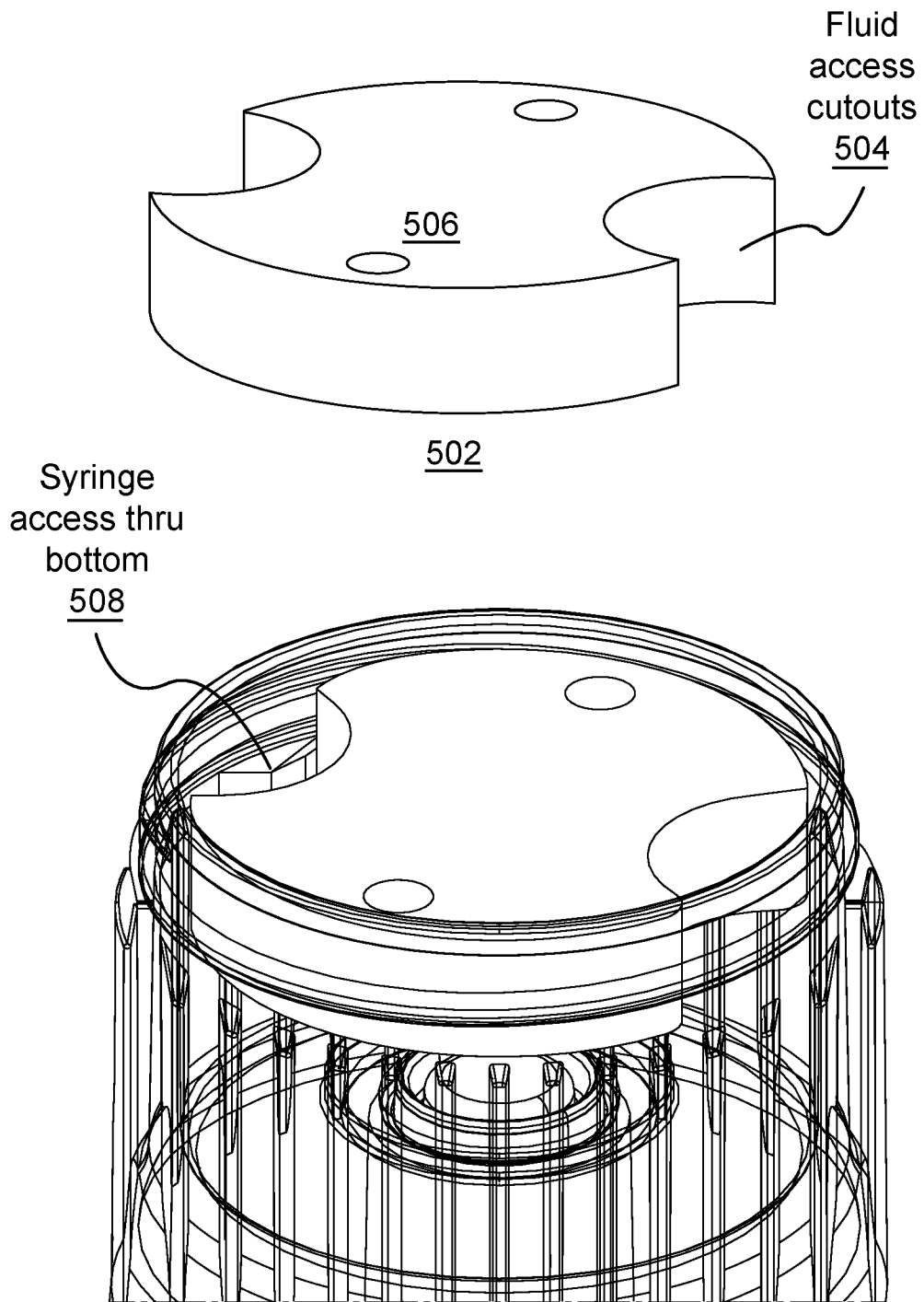

FIGURE 5

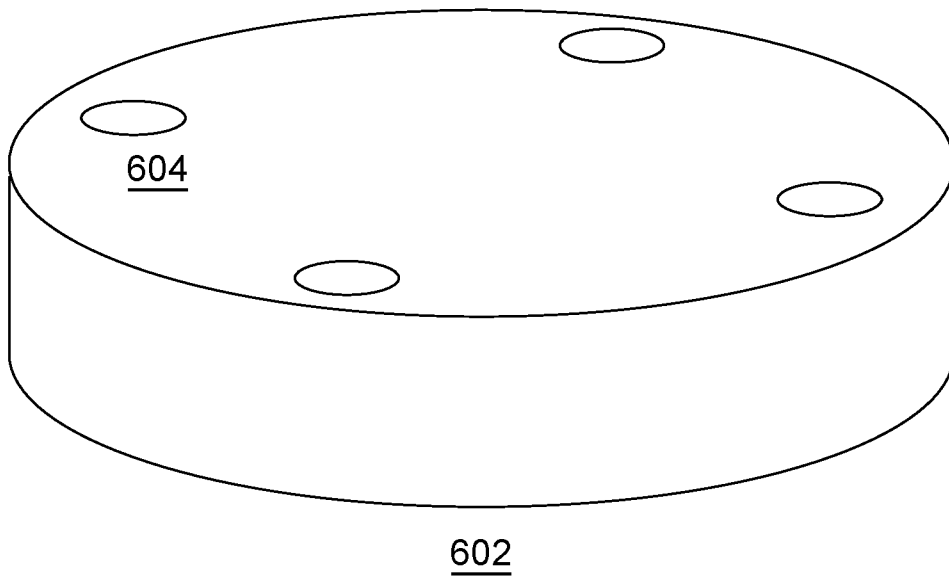
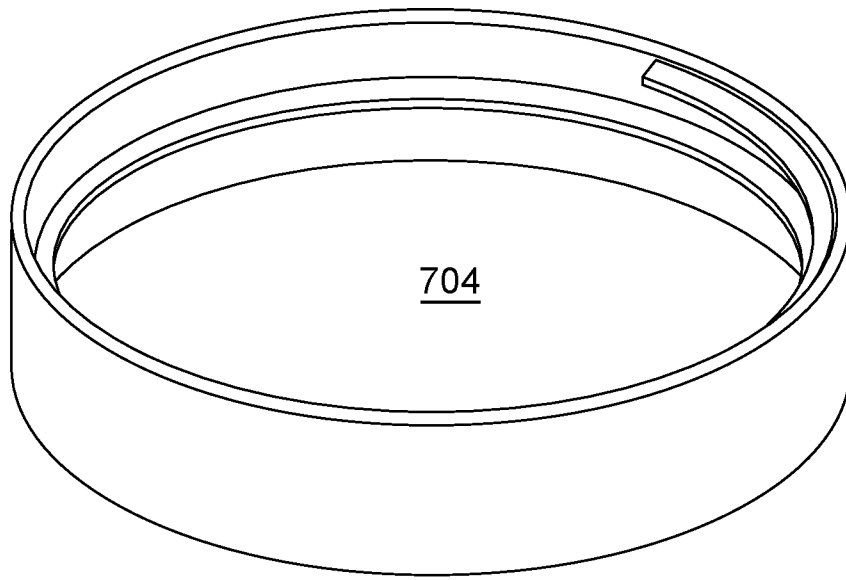

FIGURE 6

7/20



702

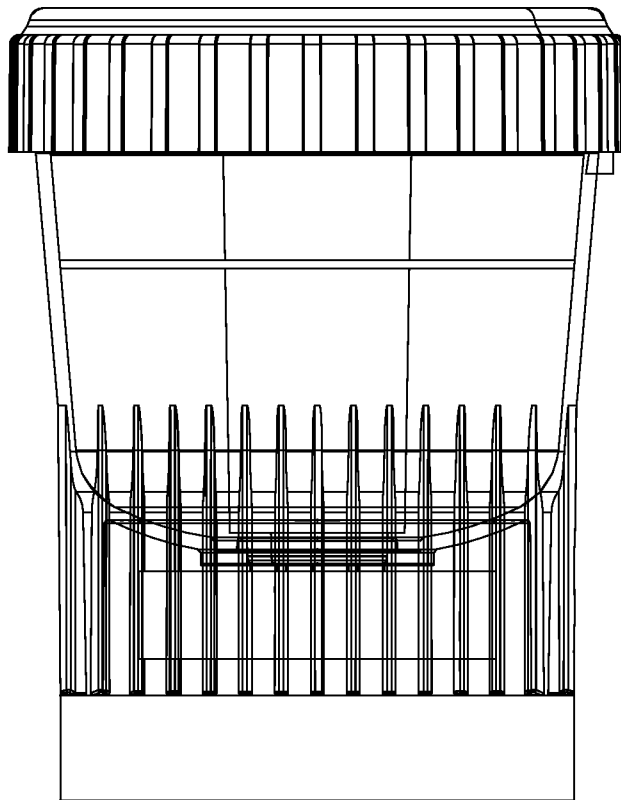
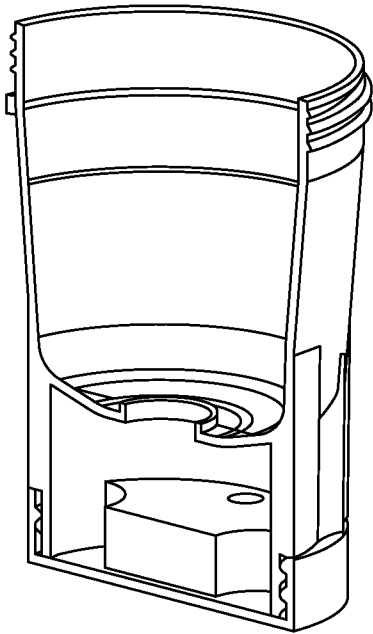
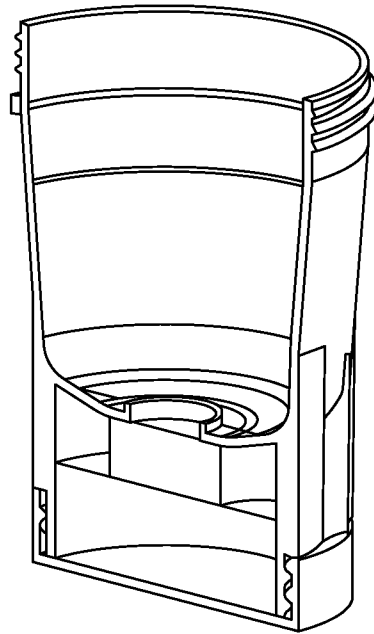

FIGURE 7



802



804

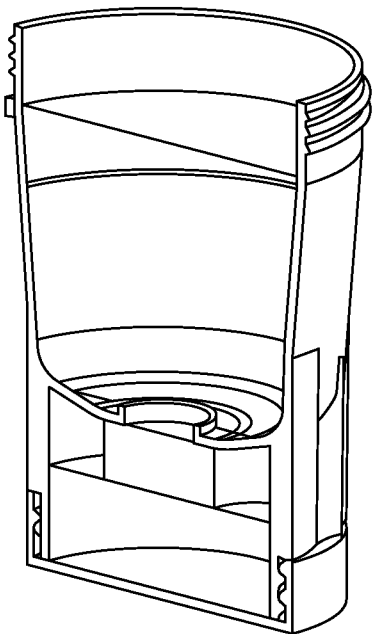

806

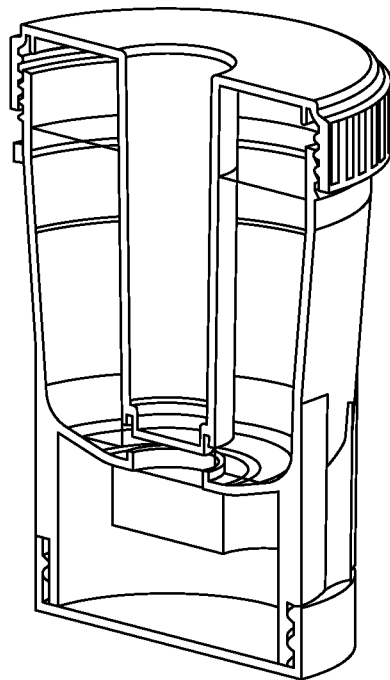

808

FIGURE 8

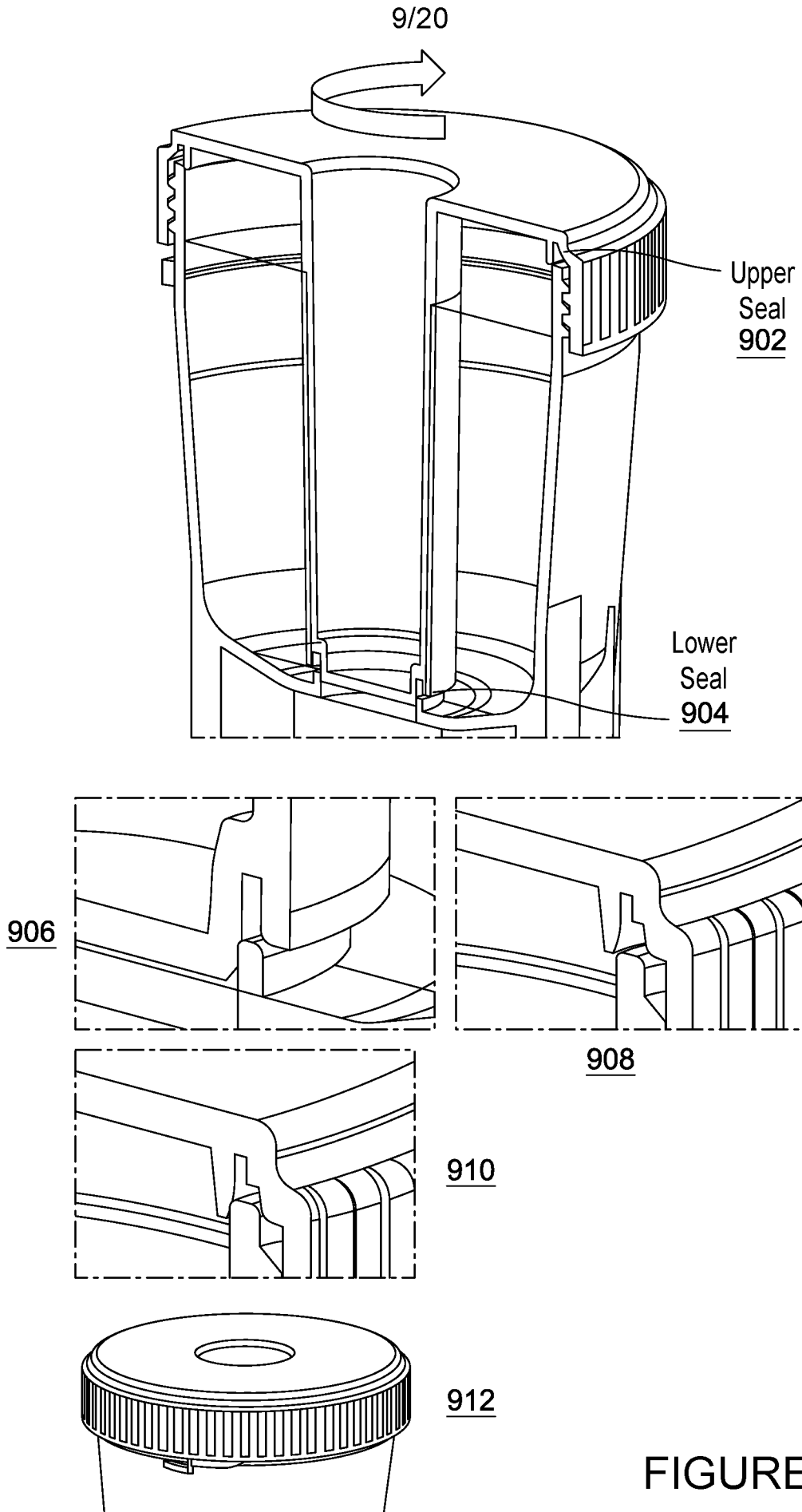

FIGURE 9

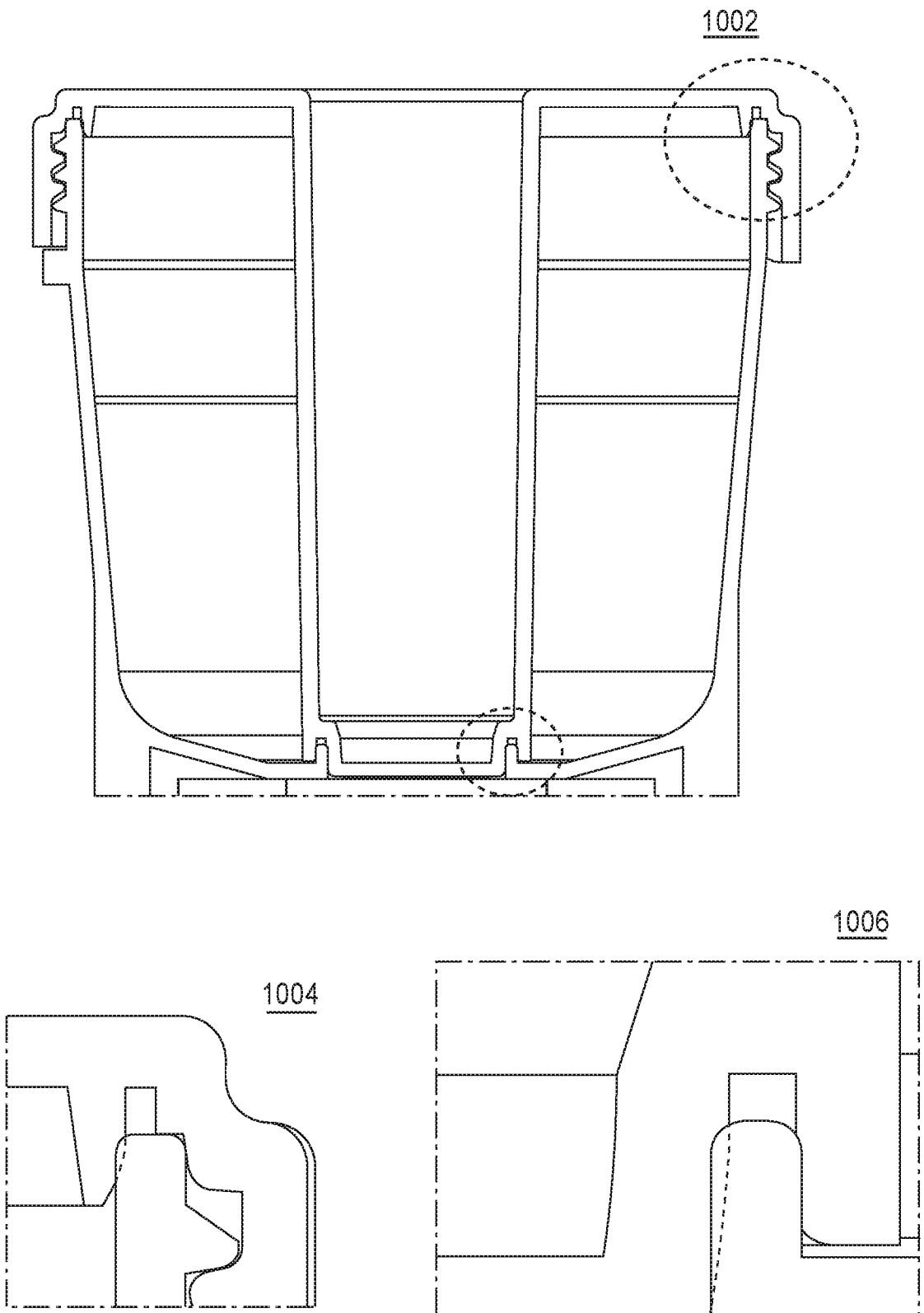
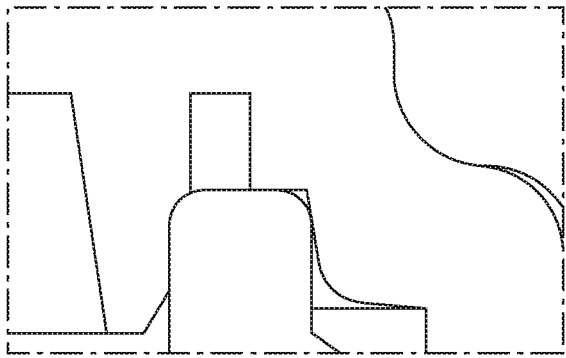
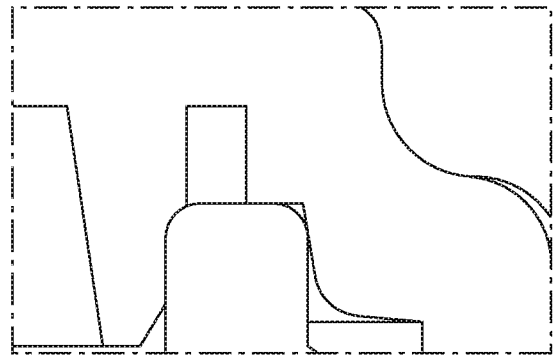

FIGURE 10



1102



1104

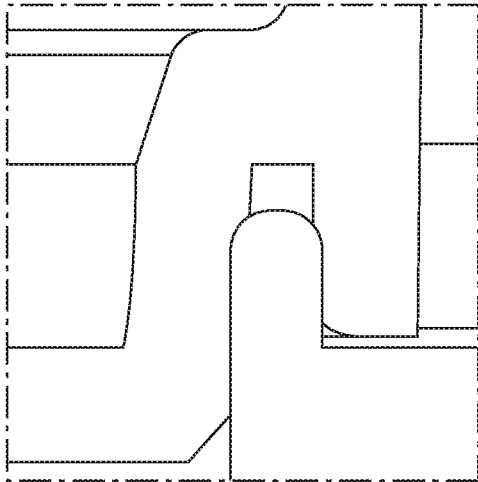

1106

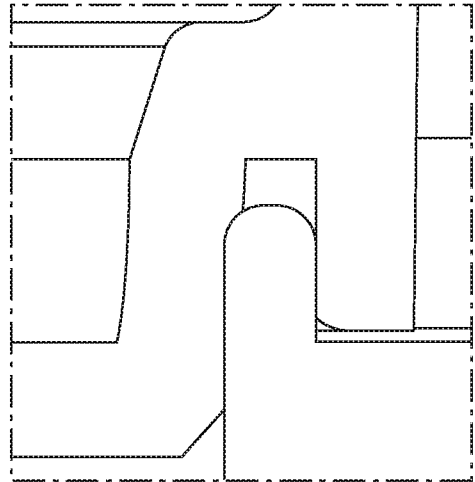

1108

FIGURE 11

12/20

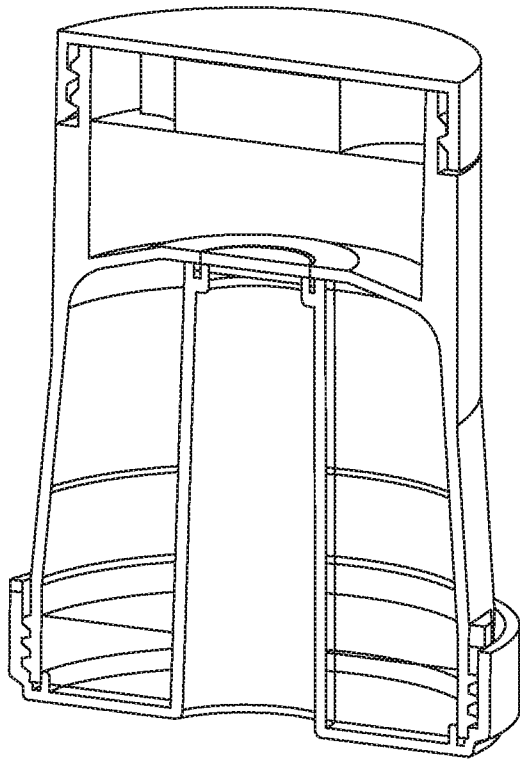

1202

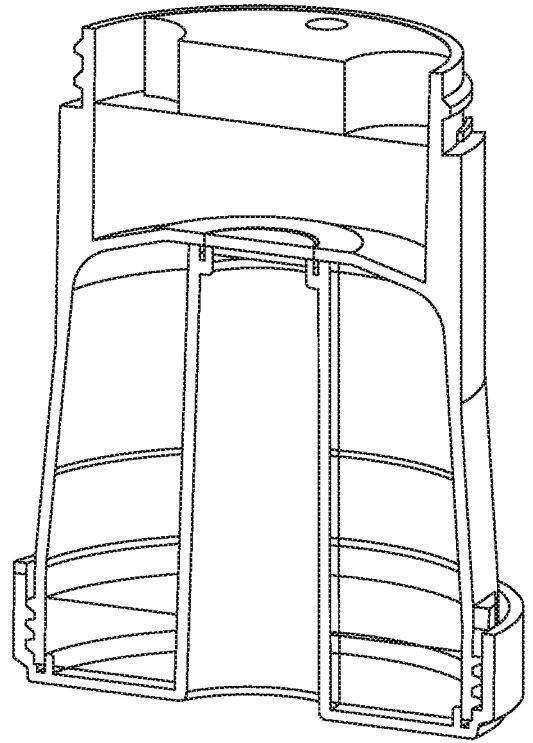

1204

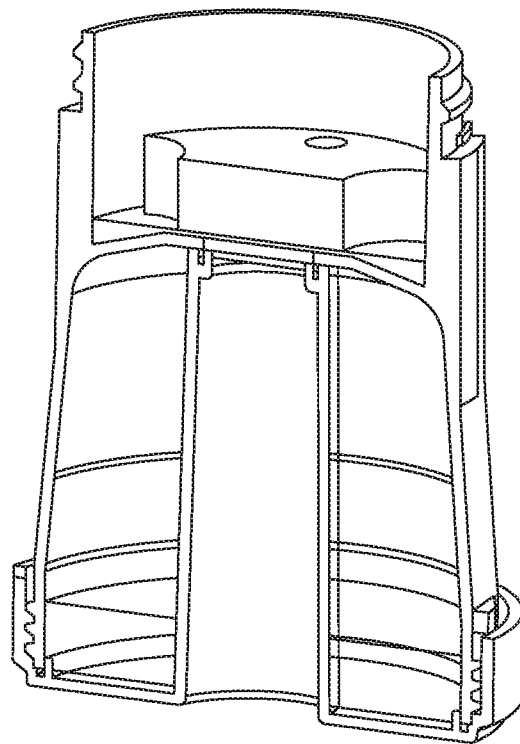

1206

FIGURE 12

13/20

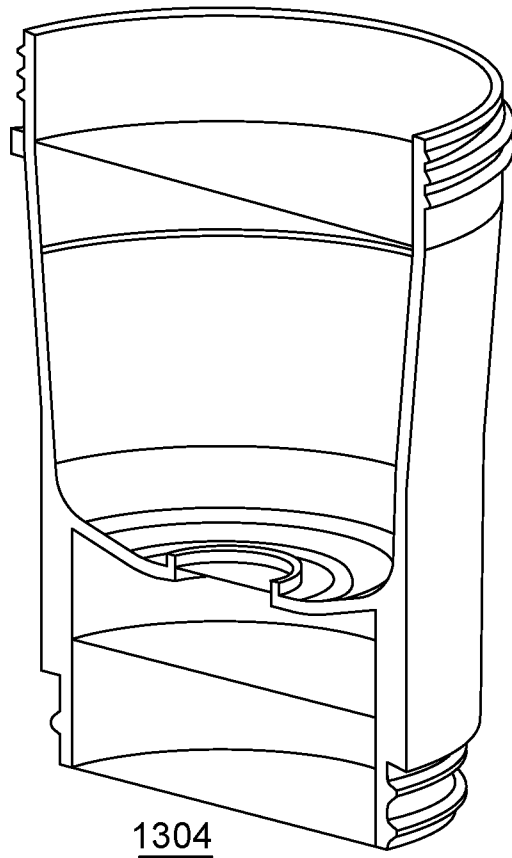
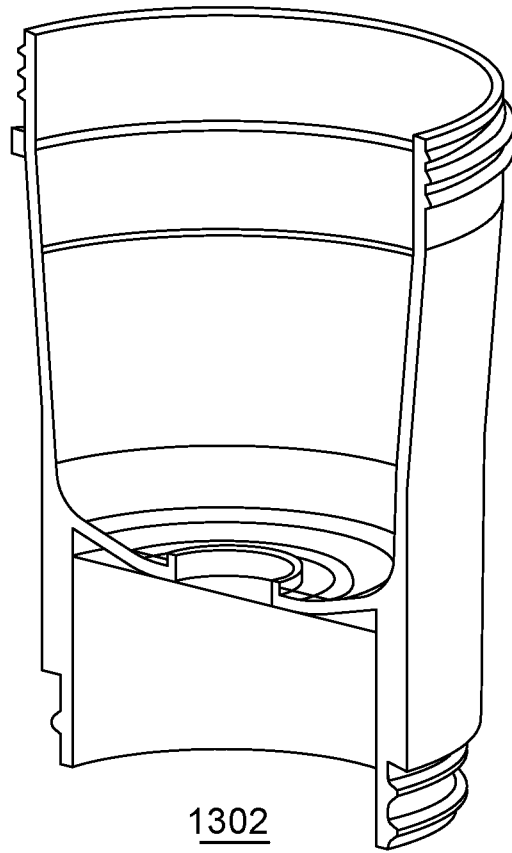

FIGURE 13

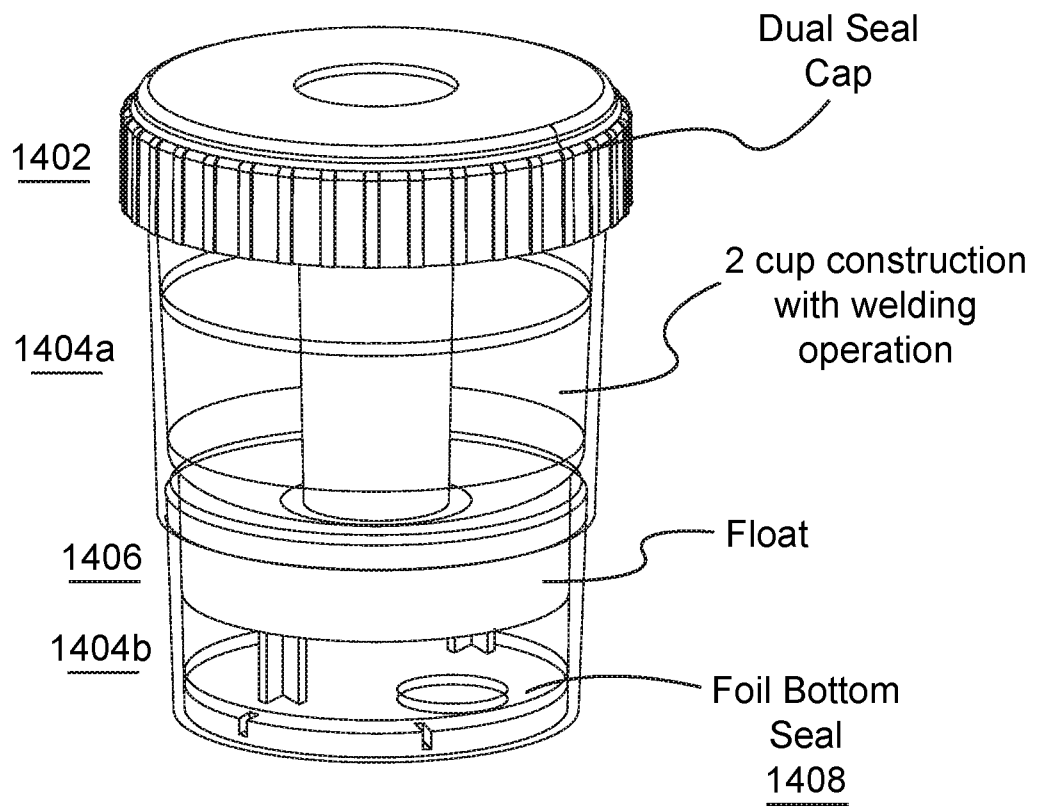

FIGURE 14

15/20

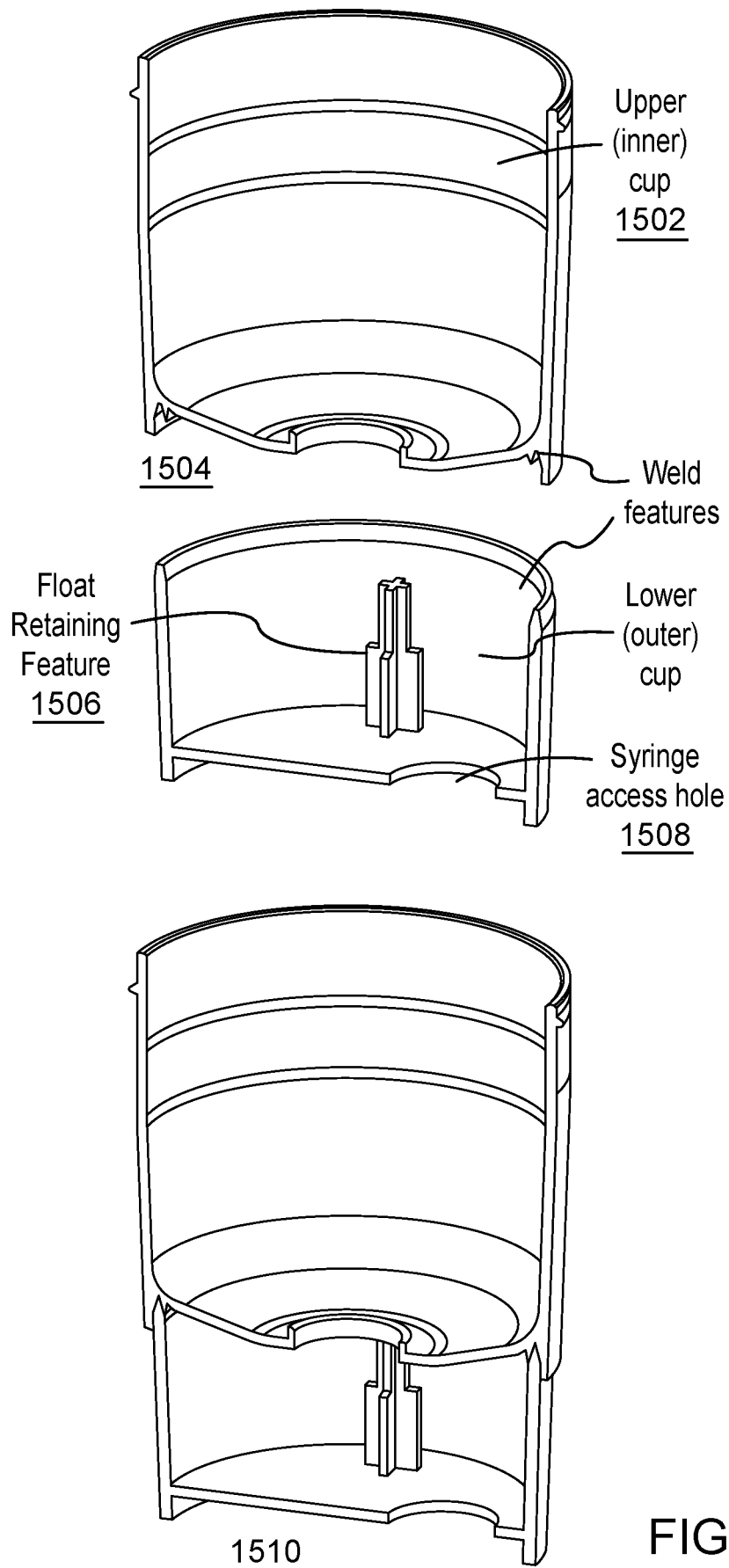

FIGURE 15

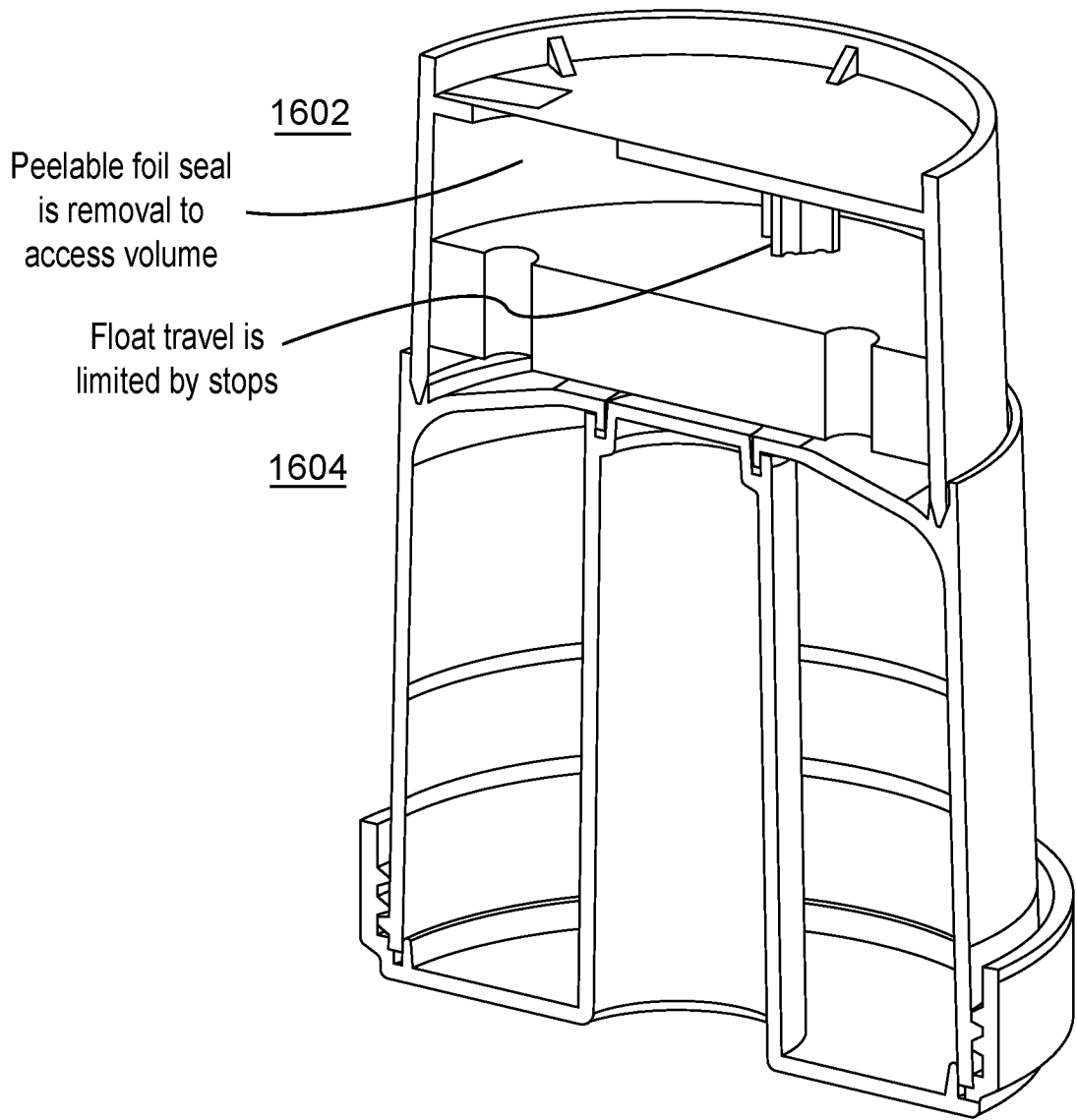

FIGURE 16

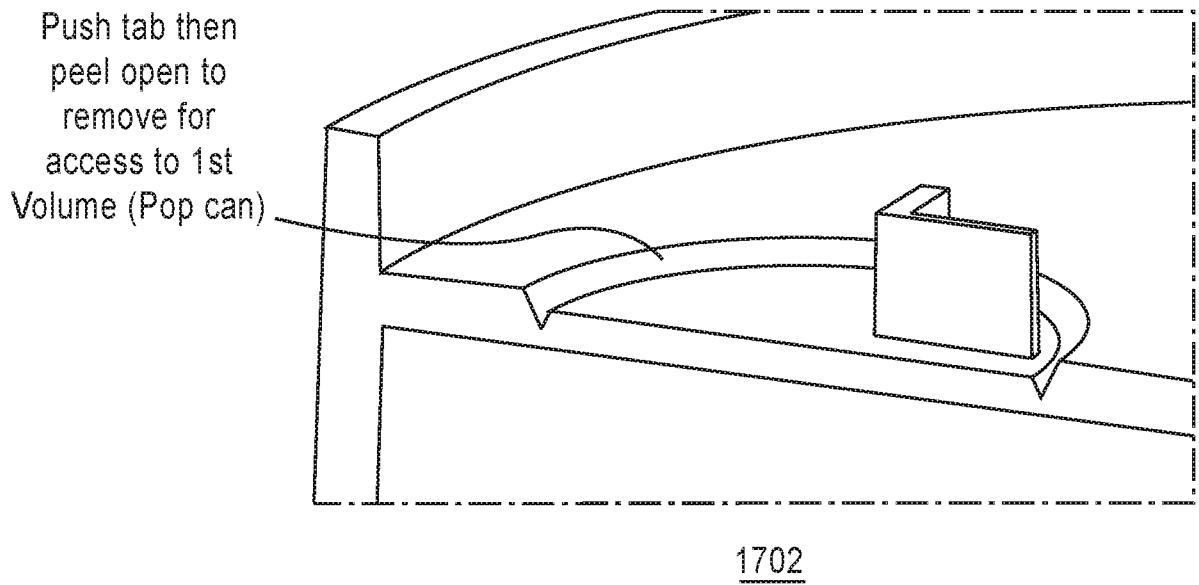
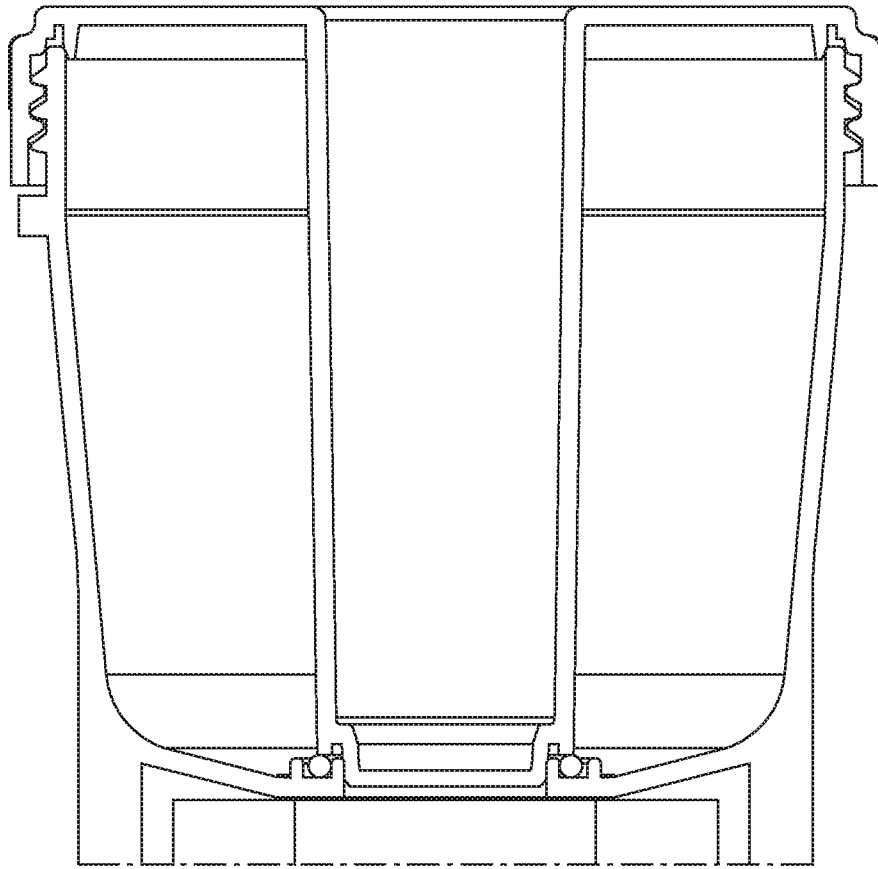
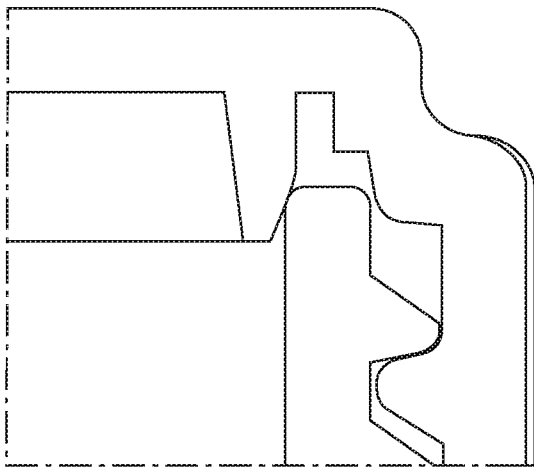

FIGURE 17



1802



1804

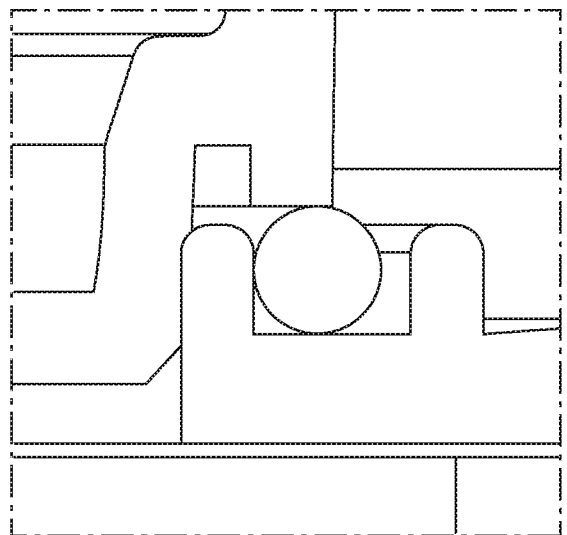

1806

FIGURE 18

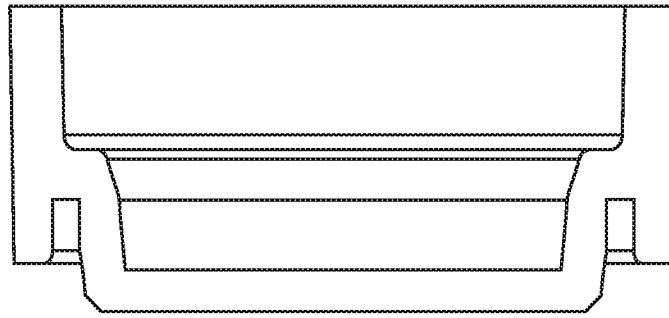

1902

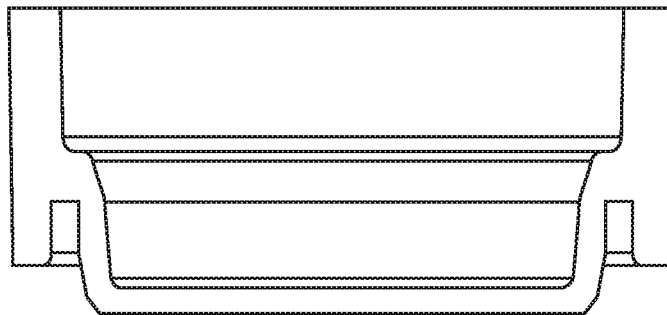

1904

FIGURE 19

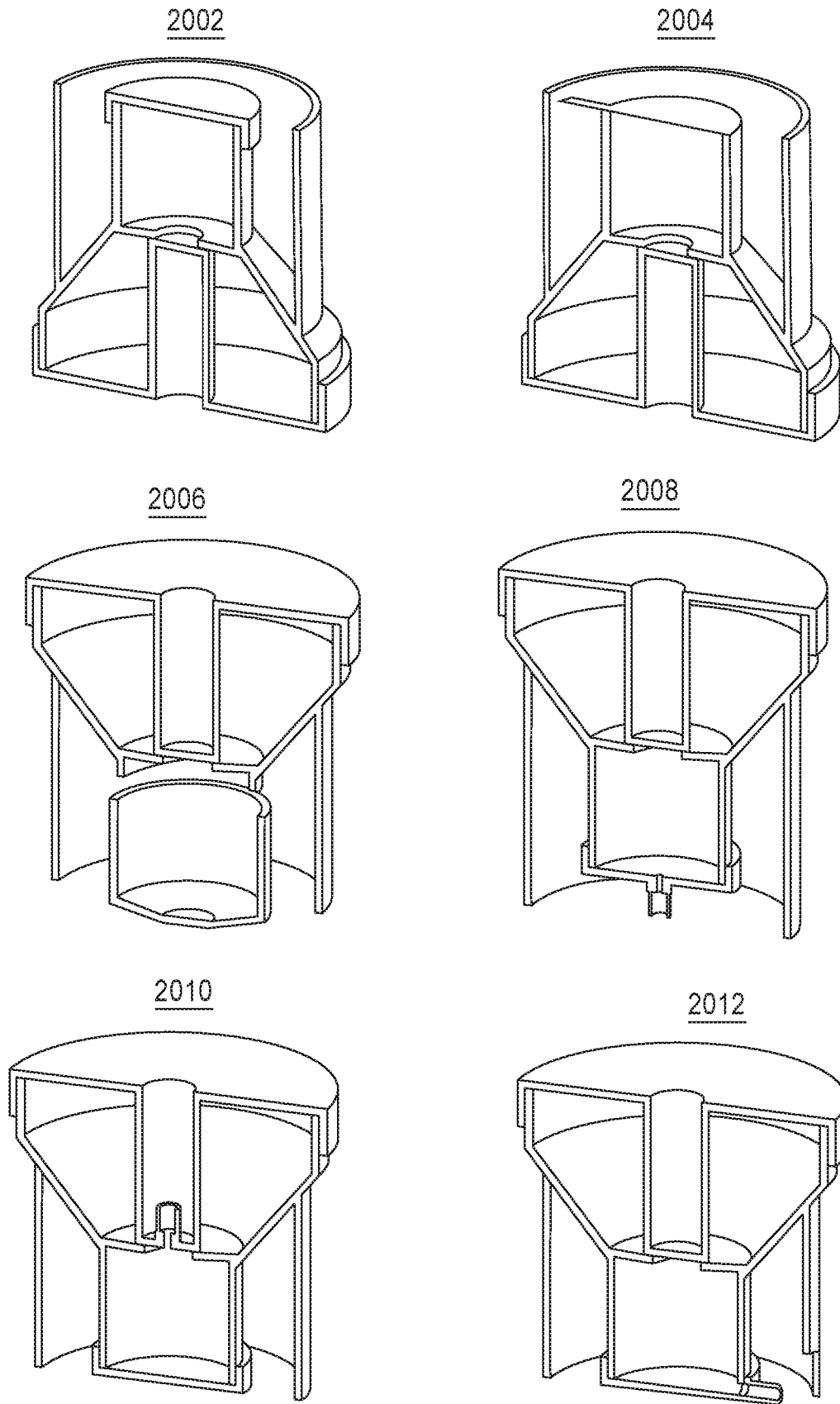

FIGURE 20

INTERNATIONAL SEARCH REPORT

International application No.

PCT/US15/53296

A. CLASSIFICATION OF SUBJECT MATTER IPC(8) - B01L 3/00, 9/00 (2015.01) CPC - B01L 3/50, 3/50215; 3/502, 3/5021 According to International Patent Classification (IPC) or to both national classification and IPC		
B. FIELDS SEARCHED Minimum documentation searched (classification system followed by classification symbols) IPC(8): B01L 3/00, 9/00 (2015.01) CPC: B01L 3/50, 3/50215; 3/502, 3/5021 Documentation searched other than minimum documentation to the extent that such documents are included in the fields searched Electronic data base consulted during the international search (name of data base and, where practicable, search terms used) PatSeer (US, EP, WO, JP, DE, GB, CN, FR, KR, ES, AU, IN, CA, INPADOC Data); Orbit; Google/Google Scholar; PubMed/MEDLINE; ProQuest: urin*, blood*, biological*, float*, piston*, volume*, seal*, separat*, top*, upper*, bottom*, lower*, cap, lid, cover*.		
C. DOCUMENTS CONSIDERED TO BE RELEVANT		
Category*	Citation of document, with indication, where appropriate, of the relevant passages	Relevant to claim No.
X -- A	US 2010/0140182 A1 (CHAPMAN, JR et al.) June 10, 2010; abstract; figures 1, 16-19; paragraphs [0130]-[0132]	21 -- 1-20, 22-23
A	US 5454958 A (FIEHLER, WR) October 03, 1995; abstract; figures 6-10; 18	1-20, 22-23
A	DE 2010/1000645 A1 (KOLPE, D et al.) September 08, 2011; see machine translation; figures 1-7	1-20, 22-23
A	DE 1991/4132480 A1 (KOLPE, D et al.) April 08, 1993; see machine translation; figures 1-2; page 6	1-20, 22-23
A	US 4961432 A (GUIRGUIS, RA) October 09, 1990; abstract; figure 7-8; column 4, lines 11-19	1-20, 22-23
A	WO 2005/014173 A1 (BECTON DICKINSON AND COMPANY) February 17, 2005; paragraph [00107]	1-20, 22-23
A	WO 2009/117212 A1 (SCIENTIFIC PLASTIC PRODUCTS, INC) September 24, 2009; abstract; figures 2, 4	1-20, 22-23
A	WO 2007/149379 A1 (FALCON WATERFREE TECHNOLOGIES, INC) December 27, 2007; entire document	1-20, 22-23
A	US 8747669 B1 (BONNER, AG et al.) June 10, 2014; entire document	1-20, 22-23
<input checked="" type="checkbox"/> Further documents are listed in the continuation of Box C. <input type="checkbox"/> See patent family annex.		
* Special categories of cited documents: "A" document defining the general state of the art which is not considered to be of particular relevance "E" earlier application or patent but published on or after the international filing date "L" document which may throw doubts on priority claim(s) or which is cited to establish the publication date of another citation or other special reason (as specified) "O" document referring to an oral disclosure, use, exhibition or other means "P" document published prior to the international filing date but later than the priority date claimed "T" later document published after the international filing date or priority date and not in conflict with the application but cited to understand the principle or theory underlying the invention "X" document of particular relevance; the claimed invention cannot be considered novel or cannot be considered to involve an inventive step when the document is taken alone "Y" document of particular relevance; the claimed invention cannot be considered to involve an inventive step when the document is combined with one or more other such documents, such combination being obvious to a person skilled in the art "&" document member of the same patent family		
Date of the actual completion of the international search 30 November 2015 (30.11.2015)		Date of mailing of the international search report 29 DEC 2015
Name and mailing address of the ISA/ Mail Stop PCT, Attn: ISA/US, Commissioner for Patents P.O. Box 1450, Alexandria, Virginia 22313-1450 Facsimile No. 571-273-8300		Authorized officer Shane Thomas PCT Helpdesk: 571-272-4300 PCT OSP: 571-272-7774

INTERNATIONAL SEARCH REPORT

International application No.

PCT/US15/53296

C (Continuation). DOCUMENTS CONSIDERED TO BE RELEVANT		
Category*	Citation of document, with indication, where appropriate, of the relevant passages	Relevant to claim No.
A	WO 2010/036895 A1 (STATSPIN, INC) April 01, 2010; entire document	1-20, 22-23
A	US 2003/0021727 A1 (WEYKER, DC et al.) January 30, 2003; entire document	1-20, 22-23