

**(12) STANDARD PATENT**  
**(19) AUSTRALIAN PATENT OFFICE**

(11) Application No. **AU 2009308304 B2**

(54) Title  
**Methods and apparatus to perform audio watermarking and watermark detection and extraction**

(51) International Patent Classification(s)  
**G11B 20/10** (2006.01)                      **H04H 60/37** (2008.01)  
**H04H 20/31** (2008.01)                      **H04H 60/58** (2008.01)

(21) Application No: **2009308304**                      (22) Date of Filing: **2009.10.22**

(87) WIPO No: **WO10/048458**

(30) Priority Data

(31) Number	(32) Date	(33) Country
<b>12/464,811</b>	<b>2009.05.12</b>	<b>US</b>
<b>61/108,380</b>	<b>2008.10.24</b>	<b>US</b>
<b>61/174,708</b>	<b>2009.05.01</b>	<b>US</b>

(43) Publication Date: **2010.04.29**

(44) Accepted Journal Date: **2014.04.17**

(71) Applicant(s)  
**The Nielsen Company (US), LLC,**

(72) Inventor(s)  
**Srinivasan, Venugopal; Topchy, Alexander Pavlovich**

(74) Agent / Attorney  
**Spruson & Ferguson, L 35 St Martins Tower 31 Market St, Sydney, NSW, 2000**

(56) Related Art  
**US 2001/0044899 A1 (Levy) 22 November 2001**  
**US 6968564 B1 (Srinivasan) 22 November 2005**  
**US 2003/0021441 A1 (Levy et al.) 30 January 2003**  
**US 2006/0212710 A1 (Baum et al.) 21 September 2006**

(12) INTERNATIONAL APPLICATION PUBLISHED UNDER THE PATENT COOPERATION TREATY (PCT)

(19) World Intellectual Property Organization  
International Bureau



(43) International Publication Date  
29 April 2010 (29.04.2010)

(10) International Publication Number  
**WO 2010/048458 A3**

(51) International Patent Classification:

H04H 60/37 (2008.01) H04H 60/58 (2008.01)  
G11B 20/10 (2006.01) H04H 20/31 (2008.01)

(21) International Application Number:

PCT/US2009/061749

(22) International Filing Date:

22 October 2009 (22.10.2009)

(25) Filing Language:

English

(26) Publication Language:

English

(30) Priority Data:

61/108,380 24 October 2008 (24.10.2008) US  
61/174,708 1 May 2009 (01.05.2009) US  
12/464,811 12 May 2009 (12.05.2009) US

(71) Applicant: **THE NIELSEN COMPANY (US), LLC**, [US/US]; A Delaware Limited Liability Company, 150 North Martingale Road, Schaumburg, IL 60713 (US).

(72) Inventors: **SRINIVASAN, Venugopal**; 2845 Jarvis Circle, Palm Harbor, FL 34683 (US). **TOPCHY, Alexander Pavlovich**; 7106 Waxwing Drive, New Port Richey, FL 34653 (US).

(74) Agent: **ZIMMERMAN, Michael, W.**; 150 S. Wacker Drive, Suite 2100, Chicago, IL 60606 (US).

(81) Designated States (unless otherwise indicated, for every kind of national protection available): AE, AG, AL, AM,

AO, AT, AU, AZ, BA, BB, BG, BH, BR, BW, BY, BZ, CA, CH, CL, CN, CO, CR, CU, CZ, DE, DK, DM, DO, DZ, EC, EE, EG, ES, FI, GB, GD, GE, GH, GM, GT, HN, HR, HU, ID, IL, IN, IS, JP, KE, KG, KM, KN, KP, KR, KZ, LA, LC, LK, LR, LS, LT, LU, LY, MA, MD, ME, MG, MK, MN, MW, MX, MY, MZ, NA, NG, NI, NO, NZ, OM, PE, PG, PH, PL, PT, RO, RS, RU, SC, SD, SE, SG, SK, SL, SM, ST, SV, SY, TJ, TM, TN, TR, TT, TZ, UA, UG, UZ, VC, VN, ZA, ZM, ZW.

(84) Designated States (unless otherwise indicated, for every kind of regional protection available): ARIPO (BW, GH, GM, KE, LS, MW, MZ, NA, SD, SL, SZ, TZ, UG, ZM, ZW), Eurasian (AM, AZ, BY, KG, KZ, MD, RU, TJ, TM), European (AT, BE, BG, CH, CY, CZ, DE, DK, EE, ES, FI, FR, GB, GR, HR, HU, IE, IS, IT, LT, LU, LV, MC, MK, MT, NL, NO, PL, PT, RO, SE, SI, SK, SM, TR), OAPI (BF, BJ, CF, CG, CI, CM, GA, GN, GQ, GW, ML, MR, NE, SN, TD, TG).

Published:

- with international search report (Art. 21(3))
- before the expiration of the time limit for amending the claims and to be republished in the event of receipt of amendments (Rule 48.2(h))

(88) Date of publication of the international search report:

8 July 2010

(54) Title: METHODS AND APPARATUS TO PERFORM AUDIO WATERMARKING AND WATERMARK DETECTION AND EXTRACTION

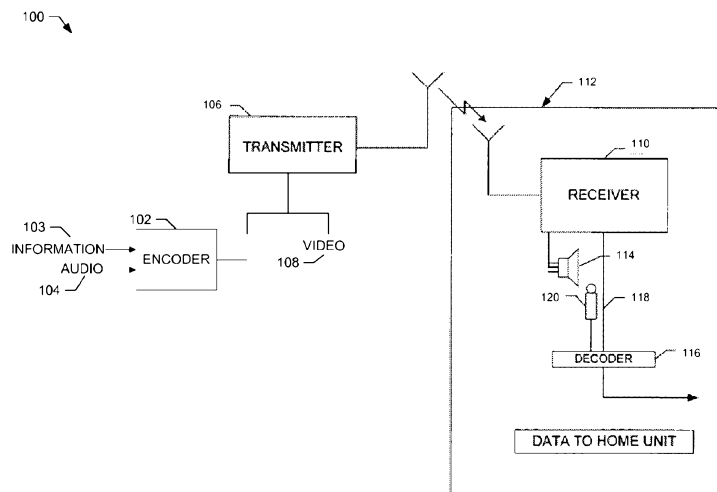

FIG. 1

(57) Abstract: Methods and apparatus to audio watermarking and watermark detection and extracted are described herein. According to an example method, an identifier is encoded in media content when a different identifier has been previously encoded. According to another example method, messages decoded from media content are validated to provide improved decoding accuracy. In another example method, decoded symbols are stored in memory and synchronization symbols are located to detect a message encoded in media content.



WO 2010/048458 A3

METHODS AND APPARATUS TO PERFORM AUDIO WATERMARKING  
AND WATERMARK DETECTION AND EXTRACTION

RELATED APPLICATIONS

[0001] This application claims the benefit of U.S. Provisional Application Serial No. 61/174,708 filed May 1, 2009, entitled "METHODS AND APPARATUS TO PERFORM AUDIO WATERMARKING AND WATERMARK DETECTION AND EXTRACTION" and U.S. Provisional Application Serial No. 61/108,380, filed October 24, 2008, entitled "STACKING METHOD FOR ADVANCED WATERMARK DETECTION." The disclosures of which are incorporated by reference in their entirety.

TECHNICAL FIELD

[0002] The present disclosure relates generally to media monitoring and, more particularly, to methods and apparatus to perform audio watermarking and watermark detection and extraction.

BACKGROUND

[0003] Identifying media information and, more specifically, audio streams (e.g., audio information) is useful for assessing audience exposure to television, radio, or any other media. For example, in television audience metering applications, a code may be inserted into the audio or video of media, wherein the code is later detected at monitoring sites when the media is presented (e.g., played at monitored households). The information payload of the code/watermark embedded into original signal can consist of unique source identification, time of broadcast information, transactional information or additional content metadata.

[0004] Monitoring sites typically include locations such as, for example, households where the media consumption of audience members or audience member exposure to the media is monitored. For example, at a monitoring site, codes from the audio and/or video are captured and may be associated with audio or video streams of media associated with a selected channel, radio station, media source, etc. The collected codes may then be sent to a central data collection

facility for analysis. However, the collection of data pertinent to media exposure or consumption need not be limited to in-home exposure or consumption.

#### BRIEF DESCRIPTION OF THE DRAWINGS

[0005] FIG. 1 is a schematic depiction of a broadcast audience measurement system employing a program identifying code added to the audio portion of a composite television signal.

[0006] FIG. 2 is a block diagram of an example encoder of FIG. 1.

[0007] FIG. 3 is a flow diagram illustrating an example encoding process that may be carried out by the example decoder of FIG. 2.

[0008] FIG. 4 is a flow diagram illustrating an example process that may be carried to generate a frequency index table used in conjunction with the code frequency selector of FIG. 2.

[0009] FIG. 5 is a chart illustrating critical band indices and how they correspond to short and long block sample indices.

[0010] FIG. 6 illustrates one example of selecting frequency components that will represent a particular information symbol.

[0011] FIGS. 7-9 are charts illustrating different example code frequency configurations that may be generated by the process of FIG. 4 and used in conjunction with the code frequency selector of FIG. 2.

[0012] FIG. 10 illustrates the frequency relationship between the audio encoding indices.

[0013] FIG. 11 is a block diagram of the example decoder of FIG. 1.

[0014] FIG. 12 is a flow diagram illustrating an example decoding process that may be carried out by the example encoder of FIG. 11.

[0015] FIG. 13 is a flow diagram of an example process that may be carried out to stack audio in the decoder of FIG. 11.

[0016] FIG. 14 is a flow diagram of an example process that may be carried out to determine a symbol encoded in an audio signal in the decoder of FIG. 11.

[0017] FIG. 15 is a flow diagram of an example process that may be carried out to process a buffer to identify messages in the decoder of FIG. 11.

[0018] FIG. 16 illustrates an example set of circular buffers that may store message symbols.

[0019] FIG. 17 illustrates an example set of pre-existing code flag circular buffers that may store message symbols.

[0020] FIG. 18 is a flow diagram of an example process that may be carried out to validate identified messages in the decoder of FIG. 11.

[0021] FIG. 19 illustrates an example filter stack that may store identified messages in the decoder of FIG. 11.

[0022] FIG. 20 is a schematic illustration of an example processor platform that may be used and/or programmed to perform any or all of the processes or implement any or all of the example systems, example apparatus and/or example methods described herein.

#### DETAILED DESCRIPTION

[0023] The following description makes reference to audio encoding and decoding that is also commonly known as audio watermarking and watermark detection, respectively. It should be noted that in this context, audio may be any type of signal having a frequency falling within the normal human audibility spectrum. For example, audio may be speech, music, an audio portion of an audio and/or video program or work (e.g., a television program, a movie, an Internet video, a radio program, a commercial spot, etc.), a media program, noise, or any other sound.

[0024] In general, as described in detail below, the encoding of the audio inserts one or more codes or information (e.g., watermarks) into the audio and, ideally, leaves the code inaudible to hearers of the audio. However, there may be certain situations in which the code

may be audible to certain listeners. The codes that are embedded in audio may be of any suitable length and any suitable technique for assigning the codes to information may be selected.

**[0025]** As described below, the codes or information to be inserted into the audio may be converted into symbols that will be represented by code frequency signals to be embedded in the audio to represent the information. The code frequency signals include one or more code frequencies, wherein different code frequencies or sets of code frequencies are assigned to represent different symbols of information. Techniques for generating one or more tables mapping symbols to representative code frequencies such that symbols are distinguishable from one another at the decoder are also described. Any suitable encoding or error correcting technique may be used to convert codes into symbols.

**[0026]** By controlling the amplitude at which these code frequency signals are input into the native audio, the presence of the code frequency signals can be imperceptible to human hearing. Accordingly, in one example, masking operations based on the energy content of the native audio at different frequencies and/or the tonality or noise-like nature of the native audio are used to provide information upon which the amplitude of the code frequency signals is based.

**[0027]** Additionally, it is possible that an audio signal has passed through a distribution chain, where, for example, the content has passed from a content originator to a network distributor (e.g., NBC national) and further passed to a local content distributor (e.g., NBC in Chicago). As the audio signal passes through the distribution chain, one of the distributors may encode a watermark into the audio signal in accordance with the techniques described herein, thereby including in the audio signal an indication of that distributor's identity or the time of distribution. The encoding described herein is very robust and, therefore, codes inserted into the audio signal are not easily removed. Accordingly, any subsequent distributors of the audio content may use techniques described herein to encode the previously encoded audio signal in a manner such that the code of the subsequent distributor will be detectable and any crediting due that subsequent distributor will be acknowledged.

**[0028]** Additionally, due to the repetition or partial repetition of codes within a signal, code detection can be improved by stacking messages and transforming the encoded audio signal into a signal having an accentuated code. As the audio signal is sampled at a monitored location,

substantially equal sized blocks of audio samples are summed and averaged. This stacking process takes advantage of the temporal properties of the audio signal to cause the code signal to be accentuated within the audio signal. Accordingly, the stacking process, when used, can provide increased robustness to noise or other interference. For example, the stacking process may be useful when the decoding operation uses a microphone that might pick up ambient noise in addition to the audio signal output by a speaker.

**[0029]** A further technique to add robustness to the decoding operations described herein provides for validation of messages identified by a decoding operation. After messages are identified in an encoded audio signal, the messages are added to a stack. Subsequent repetitions of messages are then compared to identify matches. When a message can be matched to another message identified at the proper repetition interval, the messages are identified as validated. When a message can be partially matched to another message that has already been validated, the message is marked as partially validated and subsequent messages are used to identify parts of the message that may have been corrupted. According to this example validation technique, messages are only output from the decoder if they can be validated. Such a technique prevents errors in messages caused by interference and/or detection errors.

**[0030]** The following examples pertain generally to encoding an audio signal with information, such as a code, and obtaining that information from the audio via a decoding process. The following example encoding and decoding processes may be used in several different technical applications to convey information from one place to another.

**[0031]** The example encoding and decoding processes described herein may be used to perform broadcast identification. In such an example, before a work is broadcast, that work is encoded to include a code indicative of the source of the work, the broadcast time of the work, the distribution channel of the work, or any other information deemed relevant to the operator of the system. When the work is presented (e.g., played through a television, a radio, a computing device, or any other suitable device), persons in the area of the presentation are exposed not only to the work, but, unbeknownst to them, are also exposed to the code embedded in the work. Thus, persons may be provided with decoders that operate on a microphone-based platform so that the work may be obtained by the decoder using free-field detection and processed to extract

codes therefrom. The codes may then be logged and reported back to a central facility for further processing. The microphone-based decoders may be dedicated, stand-alone devices, or may be implemented using cellular telephones or any other types of devices having microphones and software to perform the decoding and code logging operations. Alternatively, wire-based systems may be used whenever the work and its attendant code may be picked up via a hard wired connection.

**[0032]** The example encoding and decoding processes described herein may be used, for example, in tracking and/or forensics related to audio and/or video works by, for example, marking copyrighted audio and/or associated video content with a particular code. The example encoding and decoding processes may be used to implement a transactional encoding system in which a unique code is inserted into a work when that work is purchased by a consumer. Thus, allowing a media distribution to identify a source of a work. The purchasing may include a purchaser physically receiving a tangible media (e.g., a compact disk, etc.) on which the work is included, or may include downloading of the work via a network, such as the Internet. In the context of transactional encoding systems, each purchaser of the same work receives the work, but the work received by each purchaser is encoded with a different code. That is, the code inserted in the work may be personal to the purchaser, wherein each work purchased by that purchaser includes that purchaser's code. Alternatively, each work may be may be encoded with a code that is serially assigned.

**[0033]** Furthermore, the example encoding and decoding techniques described herein may be used to carry out control functionality by hiding codes in a steganographic manner, wherein the hidden codes are used to control target devices programmed to respond to the codes. For example, control data may be hidden in a speech signal, or any other audio signal. A decoder in the area of the presented audio signal processes the received audio to obtain the hidden code. After obtaining the code, the target device takes some predetermined action based on the code. This may be useful, for example, in the case of changing advertisements within stores based on audio being presented in the store, etc. For example, scrolling billboard advertisements within a store may be synchronized to an audio commercial being presented in the store through the use of codes embedded in the audio commercial.



[0034] An example encoding and decoding system 100 is shown in FIG. 1. The example system 100 may be, for example, a television audience measurement system, which will serve as a context for further description of the encoding and decoding processes described herein. The example system 100 includes an encoder 102 that adds a code or information 103 to an audio signal 104 to produce an encoded audio signal. The information 103 may be any selected information. For example, in a media monitoring context, the information 103 may be representative of an identity of a broadcast media program such as a television broadcast, a radio broadcast, or the like. Additionally, the information 103 may include timing information indicative of a time at which the information 103 was inserted into audio or a media broadcast time. Alternatively, the code may include control information that is used to control the behavior of one or more target devices.

[0035] The audio signal 104 may be any form of audio including, for example, voice, music, noise, commercial advertisement audio, audio associated with a television program, live performance, etc. In the example of FIG. 1, the encoder 102 passes the encoded audio signal to a transmitter 106. The transmitter 106 transmits the encoded audio signal along with any video signal 108 associated with the encoded audio signal. While, in some instances, the encoded audio signal may have an associated video signal 108, the encoded audio signal need not have any associated video.

[0036] In one example, the audio signal 104 is a digitized version of an analog audio signal, wherein the analog audio signal has been sampled at 48 kilohertz (KHz). As described below in detail, two seconds of audio, which correspond to 96,000 audio samples at the 48 KHz sampling rate, may be used to carry one message, which may be a synchronization message and 49 bits of information. Using an encoding scheme of 7 bits per symbol, the message requires transmission of eight symbols of information. Alternatively, in the context of overwriting described below, one synchronization symbol is used and one information symbol conveying one of 128 states follows the synchronization symbol. As described below in detail, according to one example, one 7-bit symbol of information is embedded in a long block of audio samples, which corresponds to 9216 samples. In one example, such a long block includes 36 overlapping short blocks of 256 samples, wherein in a 50% overlapping block 256 of the samples are old and 256 samples are new.

[0037] Although the transmit side of the example system 100 shown in FIG. 1 shows a single transmitter 106, the transmit side may be much more complex and may include multiple levels in a distribution chain through which the audio signal 104 may be passed. For example, the audio signal 104 may be generated at a national network level and passed to a local network level for local distribution. Accordingly, although the encoder 102 is shown in the transmit lineup prior to the transmitter 106, one or more encoders may be placed throughout the distribution chain of the audio signal 104. Thus, the audio signal 104 may be encoded at multiple levels and may include embedded codes associated with those multiple levels. Further details regarding encoding and example encoders are provided below.

[0038] The transmitter 106 may include one or more of a radio frequency (RF) transmitter that may distribute the encoded audio signal through free space propagation (e.g., via terrestrial or satellite communication links) or a transmitter used to distribute the encoded audio signal through cable, fiber, etc. In one example, the transmitter 106 may be used to broadcast the encoded audio signal throughout a broad geographical area. In other cases, the transmitter 106 may distribute the encoded audio signal through a limited geographical area. The transmission may include up-conversion of the encoded audio signal to radio frequencies to enable propagation of the same. Alternatively, the transmission may include distributing the encoded audio signal in the form of digital bits or packets of digital bits that may be transmitted over one or more networks, such as the Internet, wide area networks, or local area networks. Thus, the encoded audio signal may be carried by a carrier signal, by information packets or by any suitable technique to distribute the audio signals.

[0039] When the encoded audio signal is received by a receiver 110, which, in the media monitoring context, may be located at a statistically selected metering site 112, the audio signal portion of the received program signal is processed to recover the code, even though the presence of that code is imperceptible (or substantially imperceptible) to a listener when the encoded audio signal is presented by speakers 114 of the receiver 110. To this end, a decoder 116 is connected either directly to an audio output 118 available at the receiver 110 or to a microphone 120 placed in the vicinity of the speakers 114 through which the audio is reproduced. The received audio signal can be either in a monaural or stereo format. Further details regarding decoding and example decoders are provided below.

## AUDIO ENCODING

[0040] As explained above, the encoder 102 inserts one or more inaudible (or substantially inaudible) codes into the audio 104 to create encoded audio. One example encoder 102 is shown in FIG. 2. In one implementation, the example encoder 102 of FIG. 2 may be implemented using, for example, a digital signal processor programmed with instructions to implement an encoding lineup 202, the operation of which is affected by the operations of a prior code detector 204 and a masking lineup 206, either or both of which can be implemented using a digital signal processor programmed with instructions. Of course, any other implementation of the example encoder 102 is possible. For example, the encoder 102 may be implemented using one or more processors, programmable logic devices, or any suitable combination of hardware, software, and firmware.

[0041] In general, during operation, the encoder 102 receives the audio 104 and the prior code detector 204 determines if the audio 104 has been previously encoded with information, which will make it difficult for the encoder 102 to encode additional information into the previously encoded audio. For example, a prior encoding may have been performed at a prior location in the audio distribution chain (e.g., at a national network level). The prior code detector 204 informs the encoding lineup 202 as to whether the audio has been previously encoded. The prior code detector 204 may be implemented by a decoder as described herein.

[0042] The encoding lineup 202 receives the information 103 and produces code frequency signals based thereon and combines the code frequency signal with the audio 104. The operation of the encoding lineup 202 is influenced by the output of the prior code detector 204. For example, if the audio 104 has been previously encoded and the prior code detector 204 informs the encoding lineup 202 of this fact, the encoding lineup 202 may select an alternate message that is to be encoded in the audio 104 and may also alter the details by which the alternate message is encoded (e.g., different temporal location within the message, different frequencies used to represent symbols, etc.).

[0043] The encoding lineup 202 is also influenced by the masking lineup 206. In general, the masking lineup 206 processes the audio 104 corresponding to the point in time at which the encoding lineup 202 wants to encode information and determines the amplitude at

which the encoding should be performed. As described below, the masking lineup 206 may output a signal to control code frequency signal amplitudes to keep the code frequency signal below the threshold of human perception.

**[0044]** As shown in the example of FIG. 2, the encoding lineup includes a message generator 210, a symbol selector 212, a code frequency selector 214, a synthesizer 216, an inverse Fourier transform 218, and a combiner 220. The message generator 210 is responsive to the information 103 and outputs messages having the format generally shown at reference numeral 222. The information 103 provided to the message generator may be the current time, a television or radio station identification, a program identification, etc. In one example, the message generator 210 may output a message every two seconds. Of course, other messaging intervals are possible.

**[0045]** In one example, the message format 222 representative of messages output from the message generator 210 includes a synchronization symbol 224. The synchronization symbol 224 is used by decoders, examples of which are described below, to obtain timing information indicative of the start of a message. Thus, when a decoder receives the synchronization symbol 224, that decoder expects to see additional information following the synchronization symbol 224.

**[0046]** In the example message format 222 of FIG. 2, the synchronization symbol 224, is followed by 42 bits of message information 226. This information may include a binary representation of a station identifier and coarse timing information. In one example, the timing information represented in the 42 bits of message information 226 changes every 64 seconds, or 32 message intervals. Thus, the 42 bits of message information 226 remain static for 64 seconds. The seven bits of message information 228 may be high resolution time that increments every two seconds.

**[0047]** The message format 222 also includes pre-existing code flag information 230. However, the pre-existing code flag information 230 is only selectively used to convey information. When the prior code detector 204 informs the message generator 210 that the audio 104 has not been previously encoded, the pre-existing code flag information 230 is not used. Accordingly, the message output by the message generator only includes the synchronization

symbol 224, the 42 bits of message information 226, and the seven bits of message information 228; the pre-existing code flag information 230 is blank or filled by unused symbol indications. In contrast, when the prior code detector 204 provides to the message generator 210 an indication that the audio 104 into which the message information is to be encoded has previously been encoded, the message generator 210 will not output the synchronization symbol 224, the 42 bits of message information 226, or the seven bits of message information 228. Rather, the message generator 210 will utilize only the pre-existing code flag information 230. In one example, the pre-existing code flag information will include a pre-existing code flag synchronization symbol to signal that pre-existing code flag information is present. The pre-existing code flag synchronization symbol is different from the synchronization symbol 224 and, therefore, can be used to signal the start of pre-existing code flag information. Upon receipt of the pre-existing code flag synchronization symbol, a decoder can ignore any prior-received information that aligned in time with a synchronization symbol 224, 42 bits of message information 226, or seven bits of message information 228. To convey information, such as a channel indication, a distribution identification, or any other suitable information, a single pre-existing code flag information symbol follows the pre-existing code flag synchronization symbol. This pre-existing code flag information may be used to provide for proper crediting in an audience monitoring system.

**[0048]** The output from the message generator 210 is passed to the symbol selector 212, which selects representative symbols. When the synchronization symbol 224 is output, the symbol selector 212 may not need to perform any mapping because the synchronization symbol 224 is already in symbol format. Alternatively, if bits of information are output from the message generator 210, the symbol selector 212 may use straight mapping, wherein, for example seven bits output from the message generator 210 are mapped to a symbol having the decimal value of the seven bits. For example, if a value of 1010101 is output from the message generator 210, the symbol selector 212 may map those bits to the symbol 85. Of course other conversions between bits and symbols may be used. In certain examples, redundancy or error encoding may be used in the selection of symbols to represent bits. Additionally, any other suitable number of bits than seven may be selected to be converted into symbols.

The number of bits used to select the symbol may be determined based on the maximum symbol space available in the communication system. For example, if the communication system can only transmit one of four symbols at a time, then only two bits from the message generator 210 would be converted into symbols at a time.

[0049] The symbols from the symbol selector 212 are passed to the code frequency selector 214 that selects code frequencies that are used to represent the symbol. The symbol selector 212 may include one or more look up tables (LUTs) 232 that may be used to map the symbols into code frequencies that represent the symbols. That is, a symbol is represented by a plurality of code frequencies that the encoder 102 emphasizes in the audio to form encoded audio that is transmitted. Upon receipt of the encoded audio, a decoder detects the presence of the emphasized code frequencies and decodes the pattern of emphasized code frequencies into the transmitted symbol. Thus, the same LUT selected at the encoder 210 for selecting the code frequencies needs to be used in the decoder. One example LUT is described in conjunction with FIGS. 3-5. Additionally, example techniques for generating LUTs are provided in conjunction with FIGS. 7-9.

[0050] The code frequency selector 214 may select any number of different LUTs depending of various criteria. For example, a particular LUT or set of LUTs may be used by the code frequency selector 214 in response to the prior receipt of a particular synchronization symbol. Additionally, if the prior code detector 204 indicates that a message was previously encoded into the audio 104, the code frequency selector 214 may select a lookup table that is unique to pre-existing code situations to avoid confusion between frequencies used to previously encode the audio 104 and the frequencies used to include the pre-existing code flag information.

[0051] An indication of the code frequencies that are selected to represent a particular symbol is provided to the synthesizer 216. The synthesizer 216 may store, for each short block constituting a long block, three complex Fourier coefficients representative of each of the possible code frequencies that the code frequency selector 214 will indicate. These coefficients represent the transform of a windowed sinusoidal

code frequency signal whose phase angle corresponds to the starting phase angle of code sinusoid in that short block.

[0052] While the foregoing describes an example code synthesizer 216 that generates sine waves or data representing sine waves, other example implementations of code synthesizers are possible. For example, rather than generating sine waves, another example code synthesizer 216 may output Fourier coefficients in the frequency domain that are used to adjust amplitudes of certain frequencies of audio provided to the combiner 220. In this manner, the spectrum of the audio may be adjusted to include the requisite sine waves.

[0053] The three complex amplitude-adjusted Fourier coefficients corresponding to the symbol to be transmitted are provided from the synthesizer 216 to the inverse Fourier transform 218, which converts the coefficients into time-domain signals having the prescribed frequencies and amplitudes to allow their insertion into the audio to convey the desired symbols are coupled to the combiner 220. The combiner 220 also receives the audio. In particular, the combiner 220 inserts the signals from the inverse Fourier transform 218 into one long block of audio samples. As described above, for a given sampling rate of 48KHz, a long block is 9216 audio samples. In the provided example, the synchronization symbol and 49 bits of information require a total of eight long blocks. Because each long block is 9216 audio samples, only 73,728 samples of audio 104 are needed to encode a given message. However, because messages begin every two seconds, which is every 96,000 audio samples, there will be many samples at the end of the 96,000 audio samples that are not encoded. The combining can be done in the digital domain, or in the analog domain.

[0054] However, in the case of a pre-existing code flag, the pre-existing code flag is inserted into the audio 104 after the last symbol representing the previously inserted seven bits of message information. Accordingly, insertion of the pre-existing code flag information begins at sample 73,729 and runs for two long blocks, or 18,432 samples. Accordingly, when pre-existing code flag information is used, fewer of the 96,000 audio samples 104 will be unencoded.

[0055] The masking lineup 206 includes an overlapping short block maker that makes short blocks of 512 audio samples, wherein 256 of the samples are old and 256 samples are new. That is, the overlapping short block maker 240 makes blocks of 512 samples, wherein 256 samples are shifted into or out of the buffer at one time. For example, when a first set of 256 samples enters the buffer, the oldest 256 samples are shifted out of the buffer. On a subsequent iteration, the first set of 256 samples are shifted to a latter position of the buffer and 256 samples are shifted into the buffer. Each time a new short block is made by shifting in 256 new samples and removing the 256 oldest samples, the new short block is provided to a masking evaluator



242. The 512 sample block output from the overlapping short block maker 240 is multiplied by a suitable window function such that an “overlap-and-add” operation will restore the audio samples to their correct value at the output. A synthesized code signal to be added to an audio signal is also similarly windowed to prevent abrupt transitions at block edges when there is a change in code amplitude from one 512-sample block to the next overlapped 512-sample block. These transitions if present create audible artifacts.

[0056] The masking evaluator 242 receives samples of the overlapping short block (e.g., 512 samples) and determines an ability of the same to hide code frequencies to human hearing. That is, the masking evaluator determines if code frequencies can be hidden within the audio represented by the short block by evaluating each critical band of the audio as a whole to determine its energy and determining the noise-like or tonal-like attributes of each critical band and determining the sum total ability of the critical bands to mask the code frequencies. According to the illustrated example, the bandwidth of the critical bands increases with frequency. If the masking evaluator 242 determines that code frequencies can be hidden in the audio 104, the masking evaluator 204 indicates the amplitude levels at which the code frequencies can be inserted within the audio 104, while still remaining hidden and provides the amplitude information to the synthesizer 216.

[0057] In one example, the masking evaluator 242 conducts the masking evaluation by determining a maximum change in energy  $E_b$  or a masking energy level that can occur at any critical frequency band without making the change perceptible to a listener. The masking evaluation carried out by the masking evaluator 242 may be carried out as outlined in the Moving Pictures Experts Group – Advanced Audio Encoding (MPEG-AAC) audio compression standard ISO/IEC 13818-7:1997, for example. The acoustic energy in each critical band influences the masking energy of its neighbors and algorithms for computing the masking effect are described in the standards document such as ISO/IEC 13818-7:1997. These analyses may be used to determine for each short block the masking contribution due to tonality (e.g., how much the audio being evaluated is like a tone) as well as noise like (i.e., how much the audio being evaluated is like noise) features. Further analysis can evaluate temporal masking that extends masking ability of the audio over short time, typically, for 50-100 milliseconds (ms). The resulting analysis by the masking evaluator 242 provides a determination, on a per critical band

basis, the amplitude of a code frequency that can be added to the audio 104 without producing any noticeable audio degradation (e.g., without being audible).

[0058] Because a 256 sample block will appear in both the beginning of one short block and the end of the next short block and, thus, will be evaluated two times by the masking evaluator 242, the masking evaluator makes two masking evaluations including the 256 sample block. The amplitude indication provided to the synthesizer 216 is a composite of those two evaluations including that 256 sample block and the amplitude indication is timed such that the amplitude of the code inserted into the 256 samples is timed with those samples arriving at the combiner 220.

[0059] Referring now to FIGS. 3-5, an example LUT 232 is shown that includes one column representing symbols 302 and seven columns 304, 306, 308, 310, 312, 314, 316 representing numbered code frequency indices. The LUT 232 includes 128 rows, which are used to represent data symbols. Because the LUT 232 includes 128 different data symbols, data may be sent at a rate of seven bits per symbol. The frequency indices in the table may range from 180-656 and are based on a long block size of 9216 samples and a sampling rate of 48 KHz. Accordingly, the frequencies corresponding to these indices range between 937.5 Hz and 3126.6 Hz, which falls into the humanly audible range. Of course, other sampling rates and frequency indices may be selected. A description of a process to generate a LUT, such as the table 232 is provided in conjunction with FIGS. 7-9.

[0060] In one example operation of the code frequency selector 214, a symbol of 25 (e.g., a binary value of 0011001) is received from the symbol selector 212. The code frequency selector 214 accesses the LUT 232 and reads row 25 of the symbol column 302. From this row, the code frequency selector reads that code frequency indices 217, 288, 325, 403, 512, 548, and 655 are to be emphasized in the audio 104 to communicate the symbol 25 to the decoder. The code frequency selector 214 then provides an indication of these indices to the synthesizer 216, which synthesizes the code signals by outputting Fourier coefficients corresponding to these indices.

**[0061]** The combiner 220 receives both the output of the code synthesizer 216 and the audio 104 and combines them to form encoded audio. The combiner 220 may combine the output of the code synthesizer 216 and the audio 104 in an analog or digital form. If the combiner 220 performs a digital combination, the output of the code synthesizer 216 may be combined with the output of a sampler rather than the audio that is input to the sampler. For example, the audio block in digital form may be combined with the sine waves in digital form. Alternatively, the combination may be carried out in the frequency domain, wherein frequency coefficients of the audio are adjusted in accordance with frequency coefficients representing the sine waves. As a further alternative, the sine waves and the audio may be combined in analog form. The encoded audio may be output from the combiner 220 in analog or digital form. If the output of the combiner 220 is digital, it may be subsequently converted to analog form before being coupled to the transmitter 106.

**[0062]** An example encoding process 600 is shown in FIG. 6. The example process 600 may be carried out by the example encoder 102 of FIG. 2, or by any other suitable encoder. The example process 600 begins when audio samples to be encoded are received (block 602). The process 600 then determines if the received samples have been previously encoded (block 604). This determination may be carried out, for example, by the prior code detector 204 of FIG. 2, or by any suitable decoder configured to examine the audio to be encoded for evidence of a prior encoding.

**[0063]** If the received samples have not been previously encoded (block 604), the process 600 generates a communication message (block 606), such as a communication message having the format shown in FIG. 2 at reference numeral 222. In one particular example, when the audio has not been previously encoded, the communication message may include a synchronization portion and one or more portions including data bits. The communication message generation may be carried out, for example, by the message generator 210 of FIG. 2.

**[0064]** The communication message is then mapped into symbols (block 608). For example, the synchronization information need not be mapped into a symbol if the synchronization information is already a symbol. In another example, if a portion of

the communication message is a series of bits, such bits or groups of bits may be represented by one

2009308304 26 Jul 2013

symbol. As described above in conjunction with the symbol selector 212, which is one manner in which the mapping (block 608) may be carried out, one or more tables or encoding schemes may be used to convert bits into symbols. For example, some techniques may include the use of error correction coding, or the like, to increase message robustness through the use of coding gain. In one particular example implementation having a symbol space sized to accommodate 128 data symbols, seven bits may be converted into one symbol. Of course, other numbers of bits may be processed depending on many factors including available symbol space, error correction encoding, etc.

**[0065]** After the communication symbols have been selected (block 608), the process 600 selects a LUT that will be used to determine the code frequencies that will be used to represent each symbol (block 610). In one example, the selected LUT may be the example LUT 232 of FIGS. 3-5, or may be any other suitable LUT. Additionally, the LUT may be any LUT generated as described in conjunction with FIGS. 7-9. The selection of the LUT may be based on a number of factors including the synchronization symbol that is selected during the generation of the communication message (block 606).

**[0066]** After the symbols have been generated (block 608) and the LUT is selected (block 610), the symbols are mapped into code frequencies using the selected LUT (block 612). In one example in which the LUT 232 of FIG. 3-5 is selected, a symbol of, for example, 35 would be mapped to the frequency indices 218, 245, 360, 438, 476, 541, and 651. The data space in the LUT is between symbol 0 and symbol 127 and symbol 128, which uses a unique set of code frequencies that do not match any other code frequencies in the table, is used to indicate a synchronization symbol. The LUT selection (block 610) and the mapping (block 612) may be carried out by, for example, the code frequency selector 214 of FIG. 2. After the code frequencies are selected, an indication of the same is provided to, for example, the synthesizer 216 of FIG. 2.

**[0067]** Code signals including the code frequencies are then synthesized (block 614) at amplitudes according to a masking evaluation, which is described in conjunction with blocks 240 and 242 or FIG. 2, and is described in conjunction with the process 600 below. In one example, the synthesis of the code frequency signals may be carried out by providing appropriately scaled

Fourier coefficients to an inverse Fourier process. In one particular example, three Fourier coefficients may be output to represent each code frequency in the code frequency signals. Accordingly, the code frequencies may be synthesized by the inverse Fourier process in a manner in which the synthesized frequencies are windowed to prevent spill over into other portions of the signal into which the code frequency signals are being embedded. One example configuration that may be used to carry out the synthesis of block 614 is shown at blocks 216 and 218 of FIG. 2. Of course other implementations and configurations are possible.

**[0068]** After the code signals including the code frequencies have been synthesized, they are combined with the audio samples (block 616). As described in conjunction with FIG. 2, the combination of the code signals and the audio is such that one symbol is inserted into each long block of audio samples. Accordingly, to communicate one synchronization symbol and 49 data bits, information is encoded into eight long blocks of audio information: one long block for the synchronization symbol and one long block for each seven bits of data (assuming seven bits/symbol encoding). The messages are inserted into the audio at two second intervals. Thus, the eight long blocks of audio immediately following the start of a message may be encoded with audio and the remaining long blocks that make up the balance of the two second of audio may be unencoded.

**[0069]** The insertion of the code signal into the audio may be carried out by adding samples of the code signal to samples of the host audio signal, wherein such addition is done in the analog domain or in the digital domain. Alternatively, with proper frequency alignment and registration, frequency components of the audio signal may be adjusted in the frequency domain and the adjusted spectrum converted back into the time domain.

**[0070]** The foregoing described the operation of the process 600 when the process determined that the received audio samples have not been previously encoded (block 604). However, in situations in which a portion of media has been through a distribution chain and encoded as it was processed, the received samples of audio processed at block 604 already include codes. For example, a local television station using a courtesy news clip from CNN in a local news broadcast might not get viewing credit based on the prior encoding of the CNN clip. As such, additional information is added to the local news broadcast in the form of pre-existing

code flag information. If the received samples of audio have been previously encoded (block 604), the process generates pre-existing code flag information (block 618). The pre-existing code flag information may include the generation of an pre-existing code flag synchronization symbol and, for example, the generation of seven bits of data, which will be represented by a single data symbol. The data symbol may represent a station identification, a time, or any other suitable information. For example, a media monitoring site (MMS) may be programmed to detect the pre-existing code flag information to credit the station identified therein.

[0071] After the pre-existing code flag information has been generated (block 618), the process 600 selects the pre-existing code flag LUT that will be used to identify code frequencies representative of the pre-existing code flag information (block 620). In one example, the pre-existing code flag LUT may be different than other LUTs used in non-pre-existing code conditions. In one particular example, the pre-existing code flag synchronization symbol may be represented by the code frequencies 220, 292, 364, 436, 508, 580, and 652.

[0072] After the pre-existing code flag information is generated (block 618) and the pre-existing code flag LUT is selected (block 620), the pre-existing code flag symbols are mapped to code frequencies (block 612), and the remainder of the processing follows as previously described.

[0073] Sometime before the code signal is synthesized (block 614), the process 600 conducts a masking evaluation to determine the amplitude at which the code signal should be generated so that it still remains inaudible or substantially inaudible to human hearers. Accordingly, the process 600 generates overlapping short blocks of audio samples, each containing 512 audio samples (block 622). As described above, the overlapping short blocks include 50% old samples and 50% newly received samples. This operation may be carried out by, for example, the overlapping short block maker 240 of FIG. 2.

[0074] After the overlapping short blocks are generated (block 622), masking evaluations are performed on the short blocks (block 624). For example, this may be carried out as described in conjunction with block 242 of FIG. 2. The results of the masking evaluation are used by the process 600 at block 614 to determine the amplitude of the code signal to be synthesized. The overlapping short block methodology may yield two masking evaluation for a

particular 256 samples of audio (one when the 256 samples are the “new samples,” and one when the 256 samples are the “old samples”), the result provided to block 614 of the process 600 may be a composite of these masking evaluations. Of course, the timing of the process 600 is such that the masking evaluations for a particular block of audio are used to determine code amplitudes for that block of audio.

#### LOOKUP TABLE GENERATION

[0075] A system 700 for populating one or more LUTs with code frequencies corresponding to symbols may be implemented using hardware, software, combinations of hardware and software, firmware, or the like. The system 700 of FIG. 7 may be used to generate any number of LUTs, such as the LUT of FIGS. 3-5. The system 700 which operates as described below in conjunction with FIG. 7 and FIG. 8, results in a code frequency index LUT, wherein: (1) two symbols of the table are represented by no more than one common frequency index, (2) not more than one of the frequency indices representing a symbol reside in one audio critical band as defined by the MPEG-AA compression standard ISO/IEC 13818-7:1997, and (3) code frequencies of neighboring critical bands are not used to represent a single symbol. Criteria number 3 helps to ensure that audio quality is not compromised during the audio encoding process.

[0076] A critical band pair definer 702 defines a number (P) of critical band pairs. For example, referring to FIG. 9, a table 900 includes columns representing AAC critical band indices 902, short block indices 904 in the range of the AAC indices, and long block indices 906 in the range of the AAC indices. In one example, the value of P may be seven and, thus, seven critical band pairs are formed from the AAC indices (block 802). FIG. 10 shows the frequency relationship between the AAC indices. According to one example, as shown at reference numeral 1002 in FIG. 10 wherein frequencies of critical band pairs are shown as separated by dotted lines, AAC indices may be selected into pairs as follows: five and six, seven and eight, nine and ten, eleven and twelve, thirteen and fourteen, fifteen and sixteen, and seventeen and seventeen. The AAC index of seventeen includes a wide range of frequencies and, therefore, index 17 is shown twice, once for the low portion and once for the high portion.



[0077] A frequency definer 704 defines a number of frequencies (N) that are selected for use in each critical band pair. In one example, the value of N is sixteen, meaning that there are sixteen data positions in the combination of the critical bands that form each critical band pair. Reference numeral 1004 in FIG. 10 identifies the seventeen frequency positions are shown. The circled position four is reserved for synchronization information and, therefore, is not used for data.

[0078] A number generator 706 defines a number of frequency positions in the critical band pairs defined by the critical band pair definer 702. In one example the number generator 706 generates all  $N^P$ , P-digit numbers. For example, if N is 16 and P is 7, the process generates the numbers 0 through 268435456, but may do so in base 16 – hexadecimal, which would result in the values 0 through 10000000.

[0079] A redundancy reducer 708 then eliminates all number from the generated list of numbers sharing more than one common digit between them in the same position. This ensures compliance with criteria (1) above because, as described below, the digits will be representative of the frequencies selected to represent symbols. An excess reducer 710 may then further reduce the remaining numbers from the generated list of numbers to the number of needed symbols. For example, if the symbol space is 129 symbols, the remaining numbers are reduced to a count of 129. The reduction may be carried out at random, or by selecting remaining numbers with the greatest Euclidean distance, or by any other suitable data reduction technique. In another example, the reduction may be carried out in a pseudorandom manner.

[0080] After the foregoing reductions, the count of the list of numbers is equal to the number of symbols in the symbol space. Accordingly, a code frequency definer 712 defines the remaining numbers in base P format to represent frequency indices representative of symbols in the critical band pairs. For example, referring to FIG. 10, the hexadecimal number F1E4B0F is in base 16, which matches P. The first digit of the hexadecimal number maps to a frequency component in the first critical band pair, the second digit to the second critical band pair, and so on. Each digit represents the frequency index that will be used to represent the symbol corresponding to the hexadecimal number F1E4B0F.

[0081] Using the first hexadecimal number as an example of mapping to a particular frequency index, the decimal value of Fh is 15. Because position four of each critical band pair is reserved for non-data information, the value of any hexadecimal digit greater than four is incremented by the value of one decimal. Thus, the 15 becomes a 16. The 16 is thus designated (as shown with the asterisk in FIG. 10) as being the code frequency component in the first critical band pair to represent the symbol corresponding to the hexadecimal number F1E4B0F. Though not shown in FIG. 10, the index 1 position (e.g., the second position from the far left in the critical band 7) would be used to represent the hexadecimal number F1E4B0F.

[0082] A LUT filler 714 receives the symbol indications and corresponding code frequency component indications from the code frequency definer 712 and fills this information into a LUT.

[0083] An example code frequency index table generation process 800 is shown in FIG. 8. The process 800 may be implemented using the system of FIG. 7, or any other suitable configuration. The process 800 of FIG. 8 may be used to generate any number of LUTs, such as the LUT of FIGS. 3-5. While one example process 800 is shown, other processes may be used. The result of the process 800 is a code frequency index LUT, wherein: (1) two symbols of the table are represented by no more than one common frequency index, (2) not more than one of the frequency indices representing a symbol reside in one audio critical band as defined by the MPEG-AA compression standard ISO/IEC 13818-7:1997, and (3) code frequencies of neighboring critical bands are not used to represent a single symbol. Criteria number 3 helps to ensure that audio quality is not compromised during the audio encoding process.

[0084] The process 800 begins by defining a number (P) of critical band pairs. For example, referring to FIG. 9, a table 900 includes columns representing AAC critical band indices 902, short block indices 904 in the range of the AAC indices, and long block indices 906 in the range of the AAC indices. In one example, the value of P may be seven and, thus, seven critical band pairs are formed from the AAC indices (block 802). FIG. 10 shows the frequency relationship between the AAC indices. According to one example, as shown at reference numeral 1002 in FIG. 10 wherein frequencies of critical band pairs are shown as separated by dotted lines, AAC indices may be selected into pairs as follows: five and six, seven and eight,

nine and ten, eleven and twelve, thirteen and fourteen, fifteen and sixteen, and seventeen and seventeen. The AAC index of seventeen includes a wide range of frequencies and, therefore, index 17 is shown twice, once for the low portion and once for the high portion.

**[0085]** After the band pairs have been defined (block 802), a number of frequencies (N) is selected for use in each critical band pair (block 804). In one example, the value of N is sixteen, meaning that there are sixteen data positions in the combination of the critical bands that form each critical band pair. As shown in FIG. 10 as reference numeral 1004, the seventeen frequency positions are shown. The circled position four is reserved for synchronization information and, therefore, is not used for data.

**[0086]** After the number of critical band pairs and the number of frequency positions in the pairs is defined, the process 800 generates all  $N^P$ , P-digit numbers with no more than one hexadecimal digit in common (block 806). For example, if N is 16 and P is 7, the process generates the numbers 0 through 268435456, but may do so in base 16 – hexadecimal, which would result in 0 through FFFFFFFF, but does not include the numbers that share more than one common hexadecimal digit. This ensures compliance with criteria (1) above because, as described below, the digits will be representative of the frequencies selected to represent symbols.

**[0087]** According to an example process for determining a set of numbers that comply with criteria (1) above (and any other desired criteria), the numbers in the range from 0 to  $N^P-1$  are tested. First, the value corresponding to zero is stored as the first member of the result set R. Then, the numbers from 1 to  $N^P-1$  are selected for analysis to determine if they meet criteria (1) when compared to the members of R. Each number that meets criteria (1) when compared against all the current entries in R is added to the result set. In particular, according to the example process, in order to test a number K, each hexadecimal digit of interest in K is compared to the corresponding hexadecimal digit of interest in an entry M from the current result set. In the 7 comparisons not more than one hexadecimal digit of K should equal the corresponding hexadecimal digit of M. If, after comparing K against all numbers currently in the result set, no member of the latter has more than one common hexadecimal digit, then K is added

to the result set R. The algorithm iterates through the set of possible numbers until all values meeting criteria (1) have been identified.

**[0088]** While the foregoing describes an example process for determining a set of numbers that meets criteria (1), any process or algorithm may be used and this disclosure is not limited to the process described above. For example, a process may use heuristics, rules, etc. to eliminate numbers from the set of numbers before iterating throughout the set. For example, all of the numbers where the relevant bits start with two 0's, two 1's, two 2's, etc. and end with two 0's, two 1's, two 2's, etc. could immediately be removed because they will definitely have a hamming distance less than 6. Additionally or alternatively, an example process may not iterate through the entire set of possible numbers. For example, a process could iterate until enough numbers are found (e.g., 128 numbers when 128 symbols are desired). In another implementation, the process may randomly select a first value for inclusion in the set of possible values and then may search iteratively or randomly through the remaining set of numbers until a value that meets the desired criteria (e.g., criteria (1)) is found.

**[0089]** The process 800 then selects the desired numbers from the generated values (block 810). For example, if the symbol space is 129 symbols, the remaining numbers are reduced to a count of 129. The reduction may be carried out at random, or by selecting remaining numbers with the greatest Euclidean distance, or by any other suitable data reduction technique.

**[0090]** After the foregoing reductions, the count of the list of numbers is equal to the number of symbols in the symbol space. Accordingly, the remaining numbers in base P format are defined to represent frequency indices representative of symbols in the critical band pairs (block 812). For example, referring to FIG. 10, the hexadecimal number F1E4B0F is in base 16, which matches P. The first digit of the hexadecimal number maps to a frequency component in the first critical band pair, the second digit to the second critical band pair, and so on. Each digit represents the frequency index that will be used to represent the symbol corresponding to the hexadecimal number F1E4B0F.

**[0091]** Using the first hexadecimal number as an example of mapping to a particular frequency index, the decimal value of Fh is 15. Because position four of each critical band pair

is reserved for non-data information, the value of any hexadecimal digit greater than four is incremented by the value of one decimal. Thus, the 15 becomes a 16. The 16 is thus designated (as shown with the asterisk in FIG. 10) as being the code frequency component in the first critical band pair to represent the symbol corresponding to the hexadecimal number F1E4B0F. Though not shown in FIG. 10, the index 1 position (e.g., the second position from the far left in the critical band 7) would be used to represent the hexadecimal number F1E4B0F.

[0092] After assigning the representative code frequencies (block 812), the numbers are filled into a LUT (block 814).

[0093] Of course, the systems and processes described in conjunction with FIGS. 8-10 are only examples that may be used to generate LUTs having desired properties in conjunction the encoding and decoding systems described herein. Other configurations and processes may be used.

#### AUDIO DECODING

[0094] In general, the decoder 116 detects a code signal that was inserted into received audio to form encoded audio at the encoder 102. That is, the decoder 116 looks for a pattern of emphasis in code frequencies it processes. Once the decoder 116 has determined which of the code frequencies have been emphasized, the decoder 116 determines, based on the emphasized code frequencies, the symbol present within the encoded audio. The decoder 116 may record the symbols, or may decode those symbols into the codes that were provided to the encoder 102 for insertion into the audio.

[0095] In one implementation, the example decoder 116 of FIG. 11 may be implemented using, for example, a digital signal processor programmed with instructions to implement components of the decoder 116. Of course, any other implementation of the example decoder 116 is possible. For example, the decoder 116 may be implemented using one or more processors, programmable logic devices, or any suitable combination of hardware, software, and firmware.

[0096] As shown in FIG. 11, an example decoder 116 includes a sampler 1102, which may be implemented using an analog to digital converter (A/D) or any other suitable technology, to which encoded audio is provided in analog format. As shown in FIG. 1, the encoded audio

may be provided by a wired or wireless connection to the receiver 110. The sampler 1102 samples the encoded audio at, for example, a sampling frequency of 8 KHz. Of course, other sampling frequencies may be advantageously selected in order to increase resolution or reduce the computational load at the time of decoding. At a sampling frequency of 8 KHz, the Nyquist frequency is 4 KHz and, therefore, all of the embedded code signal is preserved because its spectral frequencies are lower than the Nyquist frequency. The 9216-sample FFT long block length at 48 KHz sampling rate is reduced to 1536 samples at 8 KHz sampling rate. However even at this modified DFT block size, the code frequency indices are identical to the original encoding frequencies and range from 180 to 656.

[0097] The samples from the sampler 1102 are provided to a stacker 1104. In general, the stacker 1104 accentuates the code signal in the audio signal information by taking advantage of the fact that messages are repeated or substantially repeated (e.g., only the least significant bits are changed) for a period of time. For example, 42 bits (226 of FIG. 2) of the 49 bits (226 and 224) of the previously described example message of FIG. 2 remain constant for 64 seconds (32 2-second message intervals) when the 42 bits of data 226 in the message include a station identifier and a coarse time stamp which increments once every 64 seconds. The variable data in the last 7 bit group 232 represents time increments in seconds and, thus, varies from message to message. The example stacker 1104 aggregates multiple blocks of audio signal information to accentuate the code signal in the audio signal information. In an example implementation, the stacker 1104 comprises a buffer to store multiple samples of audio information. For example, if a complete message is embedded in two seconds of audio, the buffer may be twelve seconds long to store six messages. The example stacker 1104 additionally comprises an adder to sum the audio signal information associated with the six messages and a divider to divide the sum by the number of repeated messages selected (e.g., six).

[0098] By way of example, a watermarked signal  $y(t)$  can be represented by the sum of the host signal  $x(t)$  and watermark  $w(t)$ :

$$y(t)=x(t)+w(t)$$

[0099] In the time domain, watermarks may repeat after a known period  $T$ :

$$w(t) = w(t-T)$$

[00100] According to an example stacking method, the input signal  $y(t)$  is replaced by a stacked signal  $S(t)$ :

$$S(t) = \frac{y(t) + y(t-T) + \dots + y(t-(n-1)T)}{n}$$

[00101] In the stacked signal  $S(t)$ , the contribution of the host signal decreases because the values of samples  $x(t)$ ,  $x(t-T)$ , ...,  $x(t-nT)$  are independent if the period  $T$  is sufficiently large. At the same time, the contribution of the watermarks being made of, for example, in-phase sinusoids, is enhanced.

$$S(t) = \frac{x(t) + x(t-T) + \dots + x(t-(n-1)T)}{n} + w(t)$$

[0100] Assuming  $x(t)$ ,  $x(t-T)$ , ...,  $x(t-nT)$  are independent random variables drawn from the same distribution  $X$  with zero mean  $E[X]=0$  we obtain:

$$[0101] \quad \lim_{n \rightarrow \infty} E \left[ \frac{x(t) + x(t-T) + \dots + x(t-(n-1)T)}{n} \right] \rightarrow 0,$$

[0102] and

$$[0103] \quad \text{Var} \left[ \frac{x(t) + x(t-T) + \dots + x(t-(n-1)T)}{n} \right] = \frac{\text{Var}(X)}{n}$$

[0104] Accordingly, the underlying host signal contributions  $x(t), \dots, x(t-nT)$  will effectively be canceling each other while the watermark is unchanged allowing the watermark to be more easily detected.

[0105] In the illustrated example, the power of the resulting signal decreases linearly with the number of stacked signals  $n$ . Therefore, averaging over independent portions of the host signal can reduce the effects of interference. The watermark is not affected because it will always be added in-phase.

[0106] An example process for implementing the stacker 1104 is described in conjunction with FIG. 12.

[0107] The decoder 116 may additionally include a stacker controller 1106 to control the operation of the stacker 1104. The example stacker controller 1106 receives a signal

indicating whether the stacker 1104 should be enabled or disabled. For example, the stacker controller 1106 may receive the received audio signal and may determine if the signal includes significant noise that will distort the signal and, in response to the determination, cause the stacker to be enabled. In another implementation, the stacker controller 1106 may receive a signal from a switch that can be manually controlled to enable or disable the stacker 1104 based on the placement of the decoder 116. For example, when the decoder 116 is wired to the receiver 110 or the microphone 120 is placed in close proximity to the speaker 114, the stacker controller 1106 may disable the stacker 1104 because stacking will not be needed and will cause corruption of rapidly changing data in each message (e.g., the least significant bits of a timestamp). Alternatively, when the decoder 116 is located at a distance from the speaker 114 or in another environment where significant interference may be expected, the stacker 1104 may be enabled by the stacker controller 1106. Of course, any type of desired control may be applied by the stacker controller 1106.

**[0108]** The output of the stacker 1104 is provided to a time to frequency domain converter 1108. The time to frequency domain converter 1108 may be implemented using a discrete Fourier transformation (DFT), or any other suitable technique to convert time-based information into frequency-based information. In one example, the time to frequency domain converter 1108 may be implemented using a sliding long block fast Fourier transform (FFT) in which a spectrum of the code frequencies of interest is calculated each time eight new samples are provided to the example time to time to frequency domain converter 1108. In one example, the time to frequency domain converter 1108 uses 1,536 samples of the encoded audio and determines a spectrum therefrom using 192 slides of eight samples each. The resolution of the spectrum produced by the time to frequency domain converter 1108 increases as the number of samples used to generate the spectrum is increased. Thus, the number of samples processed by the time to frequency domain converter 1108 should match the resolution used to select the indices in the tables of FIGS. 3-5.

**[0109]** The spectrum produced by the time to frequency domain converter 1108 passes to a critical band normalizer 1110, which normalizes the spectrum in each of the critical bands. In other words, the frequency with the greatest amplitude in each critical band is set to one and all other frequencies within each of the critical bands are normalized accordingly. For example,



if critical band one includes frequencies having amplitudes of 112, 56, 56, 56, 56, 56, and 56, the critical band normalizer would adjust the frequencies to be 1, 0.5, 0.5, 0.5, 0.5, 0.5, and 0.5. Of course, any desired maximum value may be used in place of one for the normalization. The critical band normalizer 1110 outputs the normalized score for each of the frequencies of the interest.

**[0110]** The spectrum of scores produced by the critical band normalizer 1110 is passed to the symbol scorer 1112, which calculates a total score for each of the possible symbols in the active symbol table. In an example implementation, the symbol scorer 1112 iterates through each symbol in the symbol table and sums the normalized score from the critical band normalizer 1110 for each of the frequencies of interest for the particular symbol to generate a score for the particular symbol. The symbol scorer 1112 outputs a score for each of the symbols to the max score selector 1114, which selects the symbol with the greatest score and outputs the symbol and the score.

**[0111]** The identified symbol and score from the max score selector 1114 are passed to the comparator 1116, which compares the score to a threshold. When the score exceeds the threshold, the comparator 1116 outputs the received symbol. When the score does not exceed the threshold, the comparator 1116 outputs an error indication. For example, the comparator 1116 may output a symbol indicating an error (e.g., a symbol not included in the active symbol table) when the score does not exceed the threshold. Accordingly, when a message has been corrupted such that a great enough score (i.e., a score that does not exceed the threshold) is not calculated for a symbol, an error indication is provided. In an example implementation, error indications may be provided to the stacker controller 1106 to cause the stacker 1104 to be enabled when a threshold number of errors are identified (e.g., number of errors over a period of time, number of consecutive errors, etc.).

**[0112]** The identified symbol or error from the comparator 1116 is passed to the circular buffers 1118 and the pre-existing code flag circular buffers 1120. An example implementation of the standard buffers 1118 is described in conjunction with FIG. 15. The example circular buffers 1118 comprise one circular buffer for each slide of the time domain to frequency domain converter 1108 (e.g., 192 buffers). Each circular buffer of the circular buffers

1118 includes one storage location for the synchronize symbol and each of the symbol blocks in a message (e.g., eight block messages would be stored in eight location circular buffers) so that an entire message can be stored in each circular buffer. Accordingly, as the audio samples are processed by the time domain to frequency domain converter 1108, the identified symbols are stored in the same location of each circular buffer until that location in each circular buffer has been filled. Then, symbols are stored in the next location in each circular buffer. In addition to storing symbols, the circular buffers 1118 may additionally include a location in each circular buffer to store a sample index indicating the sample in the audio signal that was received that resulted in the identified symbol.

[0113] The example pre-existing code flag circular buffers 1120 are implemented in the same manner as the circular buffers 1118, except the pre-existing code flag circular buffers 1120 include one location for the pre-existing code flag synchronize symbol and one location for each symbols in the pre-existing code flag message (e.g., an pre-existing code flag synchronize that includes one message symbol would be stored in two location circular buffers). The pre-existing code flag circular buffers 1120 are populated at the same time and in the same manner as the circular buffers 1118.

[0114] The example message identifier 1122 analyzes the circular buffers 1118 and the pre-existing code flag circular buffers 1120 for a synchronize symbol. For example, the message identifier 1122 searches for a synchronize symbol in the circular buffers 1118 and an pre-existing code flag synchronize symbol in the pre-existing code flag circular buffers 1120. When a synchronize symbol is identified, the symbols following the synchronize symbol (e.g., seven symbols after a synchronize symbol in the circular buffers 1118 or one symbol after an pre-existing code flag synchronize symbol in the pre-existing code flag circular buffers 1120) are output by the message identifier 1122. In addition, the sample index identifying the last audio signal sample processed is output.

[0115] The message symbols and the sample index output by the message identifier 1122 are passed to the validator 1124, which validates each message. The validator 1124 includes a filter stack that stores several consecutively received messages. Because messages are repeated (e.g., every 2 seconds or 16,000 samples at 8 KHz), each message is compared with

other messages in the filter stack that are separated by approximately the number of audio samples in a single message to determine if a match exists. If a match or substantial match exists, both messages are validated. If a message cannot be identified, it is determined that the message is an error and is not emitted from the validator 1124. In cases where messages might be affected by noise interference, messages might be considered a match when a subset of symbols in a message match the same subset in another already validated message. For example, if four of seven symbols in a message match the same four symbols in another message that has already been validated, the message can be identified as partially validated. Then, a sequence of the repeated messages can be observed to identify the non-matching symbols in the partially validated message.

[0116] The validated messages from the validator 1124 are passed to the symbol to bit converter 1126, which translates each symbol to the corresponding data bits of the message using the active symbol table.

[0117] An example decoding process 1200 is shown in FIG. 12. The example process 1200 may be carried out by the example decoder 116 shown in FIG. 11, or by any other suitable decoder. The example process 1200 begins by sampling audio (block 1202). The audio may be obtained via an audio sensor, a hardwired connection, via an audio file, or through any other suitable technique. As explained above the sampling may be carried out at 8,000 Hz, or any other suitable frequency.

[0118] As each sample is obtained, the sample is aggregated by a stacker such as the example stacker 1104 of FIG. 11 (block 1204). An example process for performing the stacking is described in conjunction with FIG. 13.

[0119] The new stacked audio samples from the stacker process 1204 are inserted into a buffer and the oldest audio samples are removed (block 1206). As each sample is obtained, a sliding time to frequency conversion is performed on a collection of samples including numerous older samples and the newly added sample obtained at blocks 1202 and 1204 (block 1208). In one example, a sliding FFT may be used to process streaming input samples including 9215 old samples and the one newly added sample. In one example, the FFT using 9216 samples results in a spectrum having a resolution of 5.2 Hz.

[0120] After the spectrum is obtained through the time to frequency conversion (block 1208), the transmitted symbol is determined (block 1210). An example process for determining the transmitted symbol is described in conjunction with FIG. 14.

[0121] After the transmitted message is identified (block 1210), buffer post processing is performed to identify a synchronize symbol and corresponding message symbols (block 1212). An example process for performing post-processing is described in conjunction with FIG. 15.

[0122] After post processing is performed to identify a transmitted message (block 1212), message validation is performed to verify the validity of the message (block 1214). An example process for performing the message validation is described in conjunction with FIG. 18.

[0123] After a message has been validated (block 1214), the message is converted from symbols to bits using the active symbol table (block 1216). Control then returns to block 1106 to process the next set of samples.

[0124] FIG. 13 illustrates an example process for stacking audio signal samples to accentuate an encoded code signal to implement the stack audio process 1204 of FIG. 12. The example process may be carried out by the stacker 1104 and the stacker controller 1106 of FIG. 11. The example process begins by determining if the stacker control is enabled (block 1302). When the stacker control is not enabled, no stacking is to occur and the process of FIG. 13 ends and control returns to block 1206 of FIG. 12 to process the audio signal samples unstacked.

[0125] When the stacker control is enabled, newly received audio signal samples are pushed into a buffer and the oldest samples are pushed out (block 1304). The buffer stores a plurality of samples. For example, when a particular message is repeatedly encoded in an audio signal every two seconds and the encoded audio is sampled at 8KHz, each message will repeat every 16,000 samples so that buffer will store some multiple of 16,000 samples (e.g., the buffer may store six messages with a 96,000 sample buffer). Then, the stacker 1108 selects substantially equal blocks of samples in the buffer (block 1306). The substantially equal blocks of samples are then summed (block 1308). For example, sample one is added to samples 16,001, 32,001, 48,001, 64,001, and 80,001, sample two is added to samples 16,002, 32,002, 48,002, 64,002, 80,002, sample 16,000 is added to samples 32,000, 48,000, 64,000, 80,000, and 96,000.

[0126] After the audio signal samples in the buffer are added, the resulting sequence is divided by the number of blocks selected (e.g., six blocks) to calculate an average sequence of samples (e.g., 16,000 averaged samples) (block 1310). The resulting average sequence of samples is output by the stacker (block 1312). The process of FIG. 13 then ends and control returns to block 1206 of FIG. 12.

[0127] FIG. 14 illustrates an example process for implementing the symbol determination process 1210 after the received audio signal has been converted to the frequency domain. The example process of FIG. 14 may be performed by the decoder 116 of FIGS. 1 and 11. The example process of FIG. 14 begins by normalizing the code frequencies in each of the critical bands (block 1402). For example, the code frequencies may be normalized so that the frequency with the greatest amplitude is set to one and all other frequencies in that critical band are adjusted accordingly. In the example decoder 116 of FIG. 11, the normalization is performed by the critical band normalizer 1110.

[0128] After the frequencies of interest have been normalized (block 1402). The example symbol scorer 1112 selects the appropriate symbol table based on the previously determined synchronization table (block 1404). For example, a system may include two symbol tables: one table for a normal synchronization and one table for an pre-existing code flag synchronization. Alternatively, the system may include a single symbol table or may include multiple synchronization tables that may be identified by synchronization symbols (e.g., cross-table synchronization symbols). The symbol scorer 1112 then computes a symbol score for each symbol in the selected symbol table (block 1406). For example, the symbol scorer 1112 may iterate across each symbol in the symbol table and add the normalized scores for each of the frequencies of interest for the symbol to compute a symbol score.

[0129] After each symbol is scored (block 1406), the example max score selector 1114 selects the symbol with the greatest score (block 1408). The example comparator 1116 then determines if the score for the selected symbol exceeds a maximum score threshold (block 1410). When the score does not exceed the maximum score threshold, an error indication is stored in the circular buffers (e.g., the circular buffers 1118 and the pre-existing code flag

circular buffers 1120) (block 1412). The process of FIG. 14 then completes and control returns to block 1212 of FIG. 12.

**[0130]** When the score exceeds the maximum score threshold (block 1410), the identified symbol is stored in the circular buffers (e.g., the circular buffers 1118 and the pre-existing code flag circular buffers 1120) (block 1414). The process of FIG. 14 then completes and control returns to block 1212 of FIG. 12.

**[0131]** FIG. 15 illustrates an example process for implementing the buffer post processing 1212 of FIG. 12. The example process of FIG. 15 begins when the message identifier 1122 of FIG. 11 searches the circular buffers 1118 and the circular buffers 1120 for a synchronization indication (block 1502).

**[0132]** For example, FIG. 16 illustrates an example implementation of circular buffers 1118 and FIG. 17 illustrates an example implementation of pre-existing code flag circular buffers 1120. In the illustrated example of FIG. 16, the last location in the circular buffers to have been filled is location three as noted by the arrow. Accordingly, the sample index indicates the location in the audio signal samples that resulted in the symbols stored in location three. Because the line corresponding to sliding index 37 is a circular buffer, the consecutively identified symbols are 128, 57, 22, 111, 37, 23, 47, and 0. Because 128 in the illustrated example is a synchronize symbol, the message can be identified as the symbols following the synchronize symbol. The message identifier 1122 would wait until 7 symbols have been located following the identification of the synchronization symbol at sliding index 37.

**[0133]** The pre-existing code flag circular buffers 1120 of FIG. 17 include two locations for each circular buffer because the pre-existing code flag message of the illustrated example comprises one pre-existing code flag synchronize symbol (e.g., symbol 254) followed by a single message symbol. According to the illustrated example of FIG. 2, the pre-existing code flag data block 230 is embedded in two long blocks immediately following the 7 bit timestamp long block 228. Accordingly, because there are two long blocks for the pre-existing code flag data and each long block of the illustrated example is 1,536 samples at a sampling rate of 8 KHz, the pre-existing code flag data symbol will be identified in the pre-existing code flag circular buffers 3072 samples after the original message. In the illustrated example FIG. 17,

sliding index 37 corresponds to sample index 38744, which is 3072 samples later than sliding index 37 of FIG. 16 (sample index 35672). Accordingly, the pre-existing code flag data symbol 68 can be determined to correspond to the message in sliding index 37 of FIG. 16, indicating that the message in sliding index 37 of FIG. 16 identifies an original encoded message (e.g., identifies an original broadcaster of audio) and the sliding index 37 identifies an pre-existing code flag message (e.g., identifies a re-broadcaster of audio).

**[0134]** Returning to FIG. 12, after a synchronize or pre-existing code flag synchronize symbol is detected, messages in the circular buffers 1118 or the pre-existing code flag circular buffers 1120 are condensed to eliminate redundancy in the messages. For example, as illustrated in FIG. 16, due to the sliding time domain to frequency domain conversion and duration of encoding for each message, messages are identified in audio data for a period of time (sliding indexes 37-39 contain the same message). The identical messages in consecutive sliding indexes can be condensed into a single message because they are representative of only one encoded message. Alternatively, condensing may be eliminated and all messages may be output when desired. The message identifier 1122 then stores the condensed messages in a filter stack associated with the validator 1124 (block 1506). The process of FIG. 15 then ends and control returns to block 1214 of FIG. 12.

**[0135]** FIG. 18 illustrates an example process to implement the message validation process 1214 of FIG. 12. The example process of FIG. 12 may be performed by the validator 1124 of FIG. 11. The example process of FIG. 18 begins when the validator 1124 reads the top message in the filter stack (block 1802).

**[0136]** For example, FIG. 19 illustrates an example implementation of a filter stack. The example filter stack includes a message index, seven symbol locations for each message index, a sample index identification, and a validation flag for each message index. Each message is added at message index M7 and a message at location M0 is the top message that is read in block 1802 of FIG. 18. Due to sampling rate variation and variation of the message boundary within a message identification, it is expected that messages will be separated by samples indexes of multiples of approximately 16,000 samples when messages are repeated every 16,000 samples.

[0137] Returning to FIG. 19, after the top message in the filter stack is selected (block 1802), the validator 1124 determines if the validation flag indicates that the message has been previously validated (block 1804). For example, FIG. 19 indicates that message M0 has been validated. When the message has been previously validated, the validator 1124 outputs the message (block 1812) and control proceeds to block 1816.

[0138] When the message has not been previously validated (block 1804), the validator 1124 determines if there is another suitably matching message in the filter stack (block 1806). A message may be suitably matching when it is identical to another message, when a threshold number of message symbols match another message (e.g., four of the seven symbols), or when any other error determination indicates that two messages are similar enough to speculate that they are the same. According to the illustrated example, messages can only be partially validated with another message that has already been validated. When a suitable match is not identified, control proceeds to block 1814.

[0139] When a suitable match is identified, the validator 1124 determines if a time duration (e.g., in samples) between identical messages is proper (block 1808). For example, when messages are repeated every 16,000 samples, it is determined if the separation between two suitably matching messages is approximately a multiple of 16,000 samples. When the time duration is not proper, control proceeds to block 1814.

[0140] When the time duration is proper (block 1808), the validator 1124 validates both messages by setting the validation flag for each of the messages (block 1810). When the message has been validated completely (e.g., an exact match) the flag may indicate that the message is fully validated (e.g., the message validated in FIG. 19). When the message has only been partially validated (e.g., only four of seven symbols matched), the message is marked as partially validated (e.g., the message partially validated in FIG. 19). The validator 1124 then outputs the top message (block 1812) and control proceeds to block 1816.

[0141] When it is determined that there is not a suitable match for the top message (block 1806) or that the time duration between a suitable match(es) is not proper (block 1808), the top message is not validated (block 1814). Messages that are not validated are not output from the validator 1124.



[0142] After determining not to validate a message (blocks 1806, 1808, and 1814) or outputting the top message (block 1812), the validator 1816 pops the filter stack to remove the top message from the filter stack. Control then returns to block 1802 to process the next message at the top of the filter stack.

[0143] While example manners of implementing any or all of the example encoder 102 and the example decoder 116 have been illustrated and described above one or more of the data structures, elements, processes and/or devices illustrated in the drawings and described above may be combined, divided, re-arranged, omitted, eliminated and/or implemented in any other way. Further, the example encoder 102 and example decoder 116 may be implemented by hardware, software, firmware and/or any combination of hardware, software and/or firmware. Thus, for example, the example encoder 102 and the example decoder 116 could be implemented by one or more circuit(s), programmable processor(s), application specific integrated circuit(s) (ASIC(s)), programmable logic device(s) (PLD(s)) and/or field programmable logic device(s) (FPLD(s)), etc. For example, the decoder 116 may be implemented using software on a platform device, such as a mobile telephone. If any of the appended claims is read to cover a purely software implementation, at least one of the prior code detector 204, the example message generator 210, the symbol selector 212, the code frequency selector 214, the synthesizer 216, the inverse FFT 218, the mixer 220, the overlapping short block maker 240, the masking evaluator 242, the critical band pair definer 702, the frequency definer 704, the number generator 706, the redundancy reducer 708, the excess reducer 710, the code frequency definer 712, the LUT filler 714, the sampler 1102, the stacker 1104, the stacker control 1106, the time domain to frequency domain converter 1108, the critical band normalize 1110, the symbol scorer 1112, the max score selector 1114, the comparator 1116, the circular buffers 1118, the pre-existing code flag circular buffers 1120, the message identifier 1122, the validator 1124, and the symbol to bit converter 1126 are hereby expressly defined to include a tangible medium such as a memory, DVD, CD, etc. Further still, the example encoder 102 and the example decoder 116 may include data structures, elements, processes and/or devices instead of, or in addition to, those illustrated in the drawings and described above, and/or may include more than one of any or all of the illustrated data structures, elements, processes and/or devices.

[0144] FIG. 20 is a schematic diagram of an example processor platform 2000 that may be used and/or programmed to implement any or all of the example encoder 102 and the decoder 116, and/or any other component described herein. For example, the processor platform 2000 can be implemented by one or more general purpose processors, processor cores, microcontrollers, etc. Additionally, the processor platform 2000 be implemented as a part of a device having other functionality. For example, the processor platform 2000 may be implemented using processing power provided in a mobile telephone, or any other handheld device.

[0145] The processor platform 2000 of the example of FIG. 20 includes at least one general purpose programmable processor 2005. The processor 2005 executes coded instructions 2010 and/or 2012 present in main memory of the processor 2005 (e.g., within a RAM 2015 and/or a ROM 2020). The processor 2005 may be any type of processing unit, such as a processor core, a processor and/or a microcontroller. The processor 2005 may execute, among other things, example machine accessible instructions implementing the processes described herein. The processor 2005 is in communication with the main memory (including a ROM 2020 and/or the RAM 2015) via a bus 2025. The RAM 2015 may be implemented by DRAM, SDRAM, and/or any other type of RAM device, and ROM may be implemented by flash memory and/or any other desired type of memory device. Access to the memory 2015 and 2020 may be controlled by a memory controller (not shown).

[0146] The processor platform 2000 also includes an interface circuit 2030. The interface circuit 2030 may be implemented by any type of interface standard, such as a USB interface, a Bluetooth interface, an external memory interface, serial port, general purpose input/output, etc. One or more input devices 2035 and one or more output devices 2040 are connected to the interface circuit 2030.

[0147] Although certain example apparatus, methods, and articles of manufacture are described herein, other implementations are possible. The scope of coverage of this patent is not limited to the specific examples described herein. On the contrary, this patent covers all apparatus, methods, and articles of manufacture falling within the scope of the invention.

2009308304 29 Apr 2011

- 5 Where the terms “comprise”, “comprises”, “comprised” or “comprising” are used in this specification, they are to be interpreted as specifying the presence of the stated features, integers, steps or components referred to, but not to preclude the presence or addition of one or more other features, integers, steps, components to be grouped therewith.

**CLAIMS:**

1. A method to transform media to include an encoding, the method comprising:  
detecting in received audio samples, a first encoding, comprising a first synchronization symbol and a first identification code, the first encoding having been encoded based on a first look-up table correlating symbols of the first encoding with characteristics of the audio samples to be modified to encode the symbols of the first encoding;

in response to the detection, generating a pre-existing code flag comprising a pre-existing code flag synchronization symbol and a second identification code, the pre-existing code flag generated based on a second look-up table correlating the pre-existing code flag synchronization symbol and symbols of the second identification code with a characteristic of the audio samples to be modified to encode the pre-existing code flag synchronization symbol and the symbols of the second identification code, wherein the pre-existing code flag synchronization symbol is encoded using a different characteristic of the audio than the first synchronization symbol;

encoding the pre-existing code flag information in the audio samples to transform the audio samples into encoded audio samples comprising the first encoding and the pre-existing code flag; and

storing the encoded audio samples in a tangible memory.

2. A method as defined in claim 1, wherein the first identification code comprises the first encoding at a first time and a second encoding at a second time and the second identification code is encoded between the first encoding and the second encoding.

3. A method as defined in claim 2, wherein encoding the pre-existing code flag comprises encoding the pre-existing code flag synchronization symbol between the first encoding and the second encoding.

4. A method as defined in claim 1, wherein the second identification code is encoded by:

identifying a set of frequencies corresponding to the second identification code;

and

emphasizing the frequencies in the set of frequencies.

5. A method as defined in claim 4, wherein the emphasizing of the frequencies comprises:
  - generating a code signal having a frequency from the set of frequencies emphasized; and
  - adding the code signal to the audio samples.
  
6. A method as defined in claim 1, wherein the first identification code identifies a first media distributor that broadcast media of the audio samples at a first time and the second identification code identifies a second media distributor that broadcast the media at a second time later than the first time.
  
7. An apparatus to transform media to include an encoding, the apparatus comprising:
  - a prior code detector to detect a first encoding in received audio samples, the first encoding comprising a first synchronization symbol and a first identification code, the first encoding having been encoded based on a first look-up table correlating symbols of the first encoding with a characteristic of the audio samples to be modified to encode the symbols of the first encoding;
  - a code frequency selector to identify a set of frequencies corresponding to a second identification code;
  - a code signal synthesizer to, in response to the detection, generate a pre-existing code flag comprising a pre-existing code flag synchronization symbol and the second identification code, the pre-existing code flag generated by a code signal having a frequency from the set of frequencies to be emphasized; and
  - a mixer to combine the pre-existing code flag and the audio samples to transform the audio samples into encoded audio samples comprising the first encoding and the pre-existing code flag, the mixer to store the encoded audio samples in a tangible memory.
  
8. An apparatus as defined in claim 7, wherein the first identification code comprises first encoding at a first time and a second encoding at a second time and the second identification code is encoded between the first encoding and the second encoding.

9. An apparatus as defined in claim 8, wherein encoding the pre-existing code flag comprises encoding the pre-existing code flag synchronization symbol between the first encoding and the second encoding.

10. An apparatus as defined in claim 7, wherein the first encoded identification code identifies a first media distributor that broadcast media of the audio samples at a first time and the second encoded identification code identifies a second media distributor that broadcast the media at a second time later than the first time.

11. A tangible computer readable storage medium comprising instructions that, when executed, cause a machine to transform media to include an encoding by at least:

detecting a first encoding in received audio samples, the first encoding comprising a first synchronization symbol and a first identification code, the first encoding having been encoded based on a first look-up table correlating symbols of the first encoding with a characteristic of the audio samples to be modified to encode the symbols of the first encoding;

in response to the detection, generating a pre-existing code flag comprising a pre-existing code flag synchronization symbol and a second identification code, the pre-existing code flag generated based on a second look-up table correlating the pre-existing code flag synchronization symbol and symbols of the second identification code with a characteristic of the audio samples to be modified to encode the pre-existing code flag synchronization symbol and the symbols of the second identification code, wherein the pre-existing code flag synchronization symbol is encoded using a different characteristic of the audio than the first synchronization symbol;

encoding the pre-existing code flag in the audio samples to transform the audio samples into encoded audio samples comprising the first encoding and the pre-existing code flag;

storing the encoded audio samples in a tangible memory.

12. A tangible computer readable medium as defined in claim 11, wherein the first identification code comprises the first encoding at a first time and a second encoding at a second time and the second identification code is encoded between the first encoding and the second encoding.

13. A tangible computer readable medium as defined in claim 12, wherein encoding the pre-existing code flag comprises encoding the pre-existing code flag synchronization symbol between the first encoding and the second encoding.
14. A tangible computer readable medium as defined in claim 11, wherein the instructions cause the machine to encode the second encoded identification code by:  
identifying a set of frequencies corresponding to the second identification code;  
and  
emphasizing the frequencies in the set of frequencies.
15. A tangible computer readable medium as defined in claim 14, wherein the instructions causing the machine to emphasize the frequencies comprises:  
generating at least one code signal having at least one frequency from the set of frequencies amplified; and  
adding the at least one code signal to the audio samples.
16. A method to transform media to include an encoding, substantially as hereinbefore described with reference to the accompanying drawings.
17. An apparatus to transform media to include an encoding, substantially as hereinbefore described with reference to the accompanying drawings.
18. A tangible computer readable storage medium comprising instructions that, when executed, cause a machine to transform media to include an encoding, substantially as hereinbefore described with reference to the accompanying drawings.

**The Nielsen Company (US), LLC**  
Patent Attorneys for the Applicant  
Spruson & Ferguson

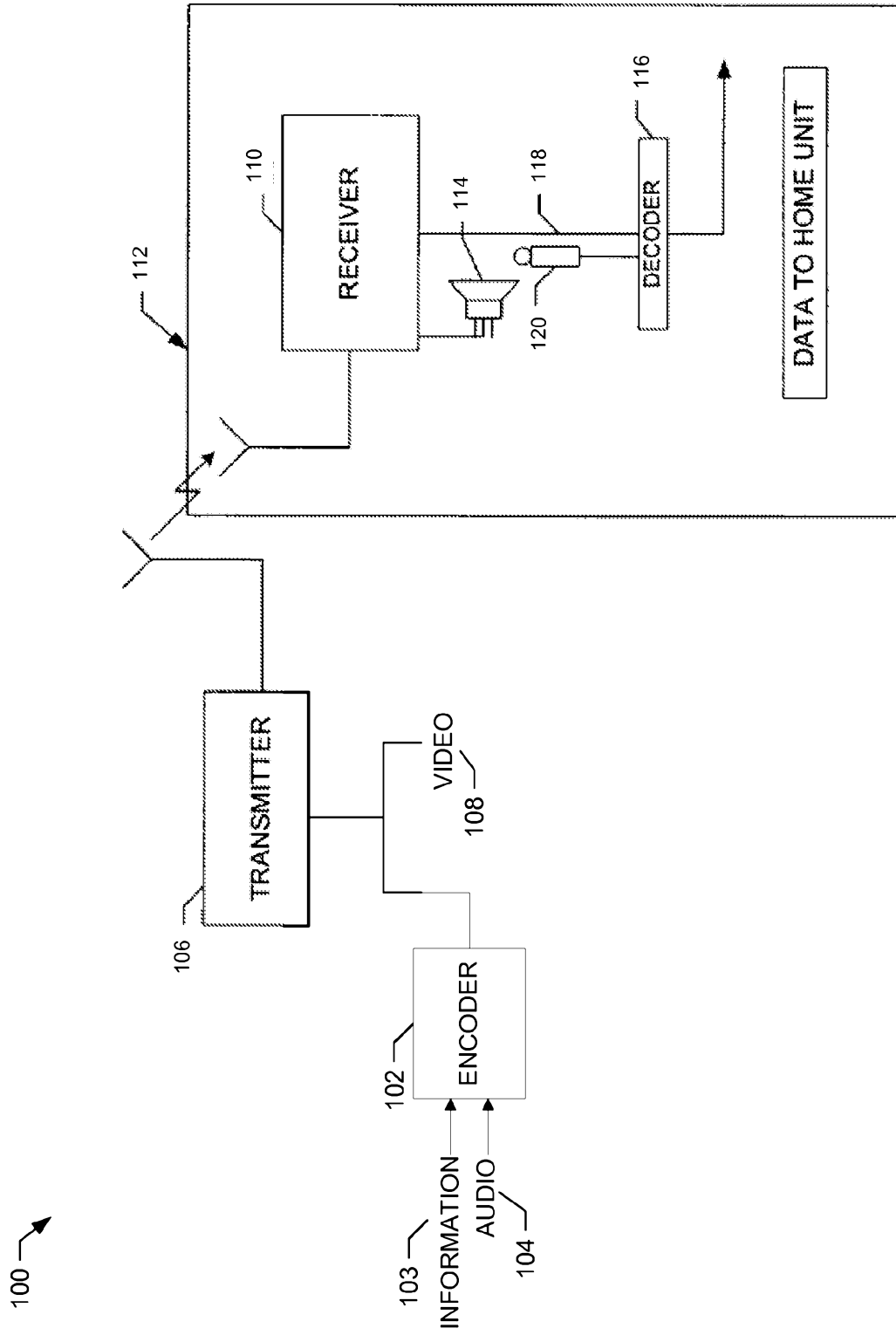

FIG. 1



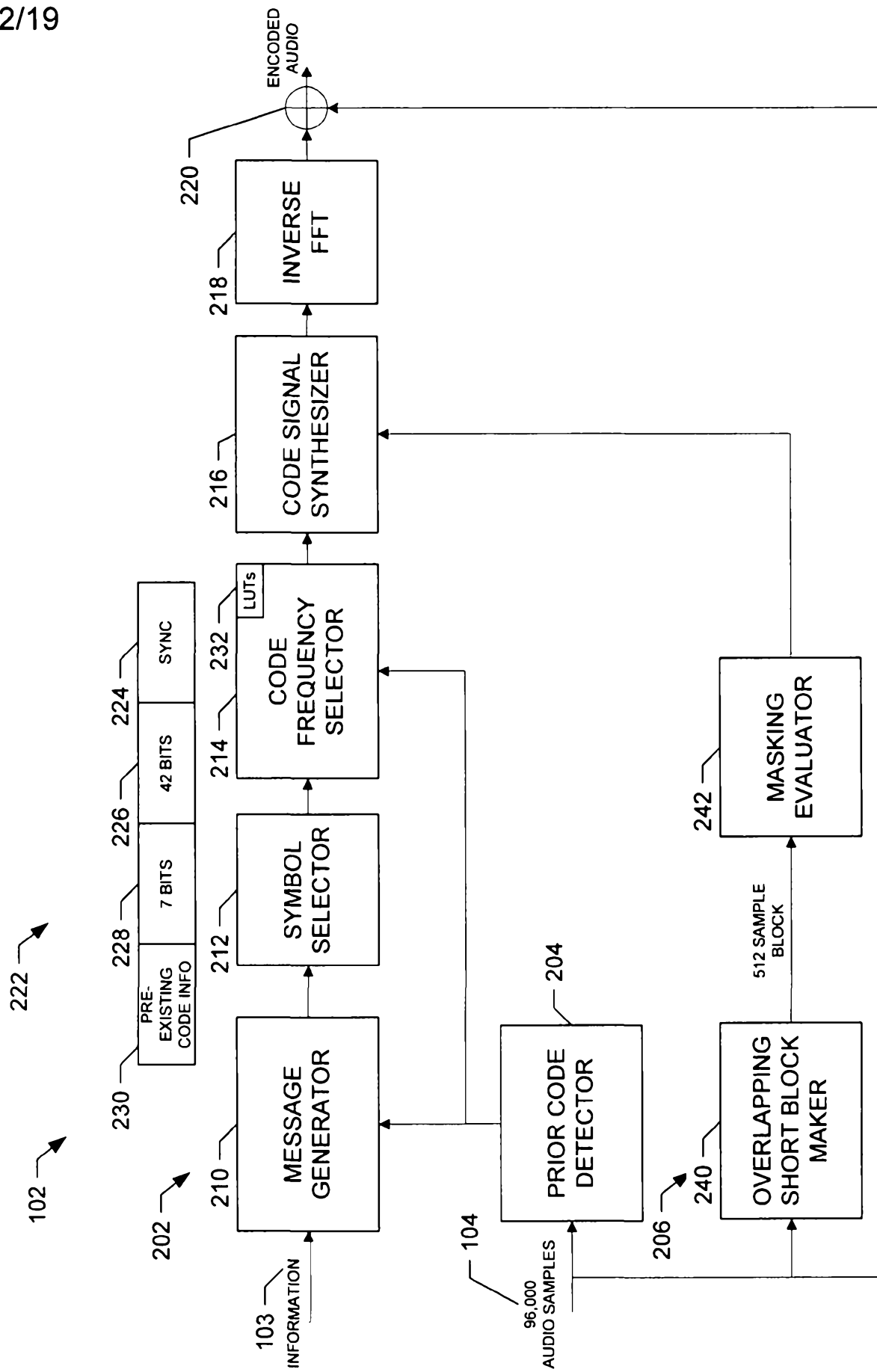

FIG. 2

302 Symbols	304	306	308	310	312	314	316
	Frequency Indices						
0	188	296	360	403	469	546	614
1	216	252	360	437	473	579	615
2	216	253	361	438	474	578	614
3	216	254	362	439	475	577	613
4	216	255	363	440	476	576	612
5	216	257	365	432	468	584	620
6	216	258	366	433	469	583	619
7	216	259	367	434	470	582	618
8	216	260	368	435	471	581	617
9	216	288	324	401	509	543	651
10	216	289	325	402	510	542	650
11	216	290	326	403	511	541	649
12	216	291	327	404	512	540	648
13	216	293	329	396	504	548	656
14	216	294	330	397	505	547	655
15	216	295	331	398	506	546	654
16	216	296	332	399	507	545	653
17	217	252	361	439	476	584	619
18	217	253	360	440	475	583	620
19	217	254	363	437	474	582	617
20	217	255	362	438	473	581	618
21	217	257	366	434	471	579	614
22	217	258	365	435	470	578	615
23	217	259	368	432	469	577	612
24	217	260	367	433	468	576	613
25	217	288	325	403	512	548	655
26	217	289	324	404	511	547	656
27	217	290	327	401	510	546	653
28	217	291	326	402	509	545	654
29	217	293	330	398	507	543	650
30	217	294	329	399	506	542	651
31	217	295	332	396	505	541	648
32	217	296	331	397	504	540	649
33	218	252	362	440	474	543	649
34	218	253	363	439	473	542	648
35	218	254	360	438	476	541	651
36	218	255	361	437	475	540	650
37	218	257	367	435	469	548	654
38	218	258	368	434	468	547	653
39	218	259	365	433	471	546	656
40	218	260	366	432	470	545	655
41	218	288	326	404	510	579	613
42	218	289	327	403	509	578	612

FIG. 3

Symbols	Frequency Indices						
43	218	290	324	402	512	577	615
44	218	291	325	401	511	576	614
45	218	293	331	399	505	584	618
46	218	294	332	398	504	583	617
47	218	295	329	397	507	582	620
48	218	296	330	396	506	581	619
49	219	252	363	438	475	548	653
50	219	253	362	437	476	547	654
51	219	254	361	440	473	546	655
52	219	255	360	439	474	545	656
53	219	257	368	433	470	543	648
54	219	258	367	432	471	542	649
55	219	259	366	435	468	541	650
56	219	260	365	434	469	540	651
57	219	288	327	402	511	584	617
58	219	289	326	401	512	583	618
59	219	290	325	404	509	582	619
60	219	291	324	403	510	581	620
61	219	293	332	397	506	579	612
62	219	294	331	396	507	578	613
63	219	295	330	399	504	577	614
64	219	296	329	398	505	576	615
65	221	252	365	401	504	582	613
66	221	253	366	402	505	581	612
67	221	254	367	403	506	584	615
68	221	255	368	404	507	583	614
69	221	257	360	396	509	577	618
70	221	258	361	397	510	576	617
71	221	259	362	398	511	579	620
72	221	260	363	399	512	578	619
73	221	288	329	437	468	546	649
74	221	289	330	438	469	545	648
75	221	290	331	439	470	548	651
76	221	291	332	440	471	547	650
77	221	293	324	432	473	541	654
78	221	294	325	433	474	540	653
79	221	295	326	434	475	543	656
80	221	296	327	435	476	542	655
81	222	252	366	403	507	577	617
82	222	253	365	404	506	576	618
83	222	254	368	401	505	579	619
84	222	255	367	402	504	578	620
85	222	257	361	398	512	582	612

FIG. 4

Symbols	Frequency Indices						
86	222	258	360	399	511	581	613
87	222	259	363	396	510	584	614
88	222	260	362	397	509	583	615
89	222	288	330	439	471	541	653
90	222	289	329	440	470	540	654
91	222	290	332	437	469	543	655
92	222	291	331	438	468	542	656
93	222	293	325	434	476	546	648
94	222	294	324	435	475	545	649
95	222	295	327	432	474	548	650
96	222	296	326	433	473	547	651
97	223	252	367	404	505	546	651
98	223	253	368	403	504	545	650
99	223	254	365	402	507	548	649
100	223	255	366	401	506	547	648
101	223	257	362	399	510	541	656
102	223	258	363	398	509	540	655
103	223	259	360	397	512	543	654
104	223	260	361	396	511	542	653
105	223	288	331	440	469	582	615
106	223	289	332	439	468	581	614
107	223	290	329	438	471	584	613
108	223	291	330	437	470	583	612
109	223	293	326	435	474	577	620
110	223	294	327	434	473	576	619
111	223	295	324	433	476	579	618
112	223	296	325	432	475	578	617
113	224	252	368	402	506	541	655
114	224	253	367	401	507	540	656
115	224	254	366	404	504	543	653
116	224	255	365	403	505	542	654
117	224	257	363	397	511	546	650
118	224	258	362	396	512	545	651
119	224	259	361	399	509	548	648
120	224	260	360	398	510	547	649
121	224	288	332	438	470	577	619
122	224	289	331	437	471	576	620
123	224	290	330	440	468	579	617
124	224	291	329	439	469	578	618
125	224	293	327	433	475	582	614
126	224	294	326	432	476	581	615
127	224	295	325	435	473	584	612

FIG. 5

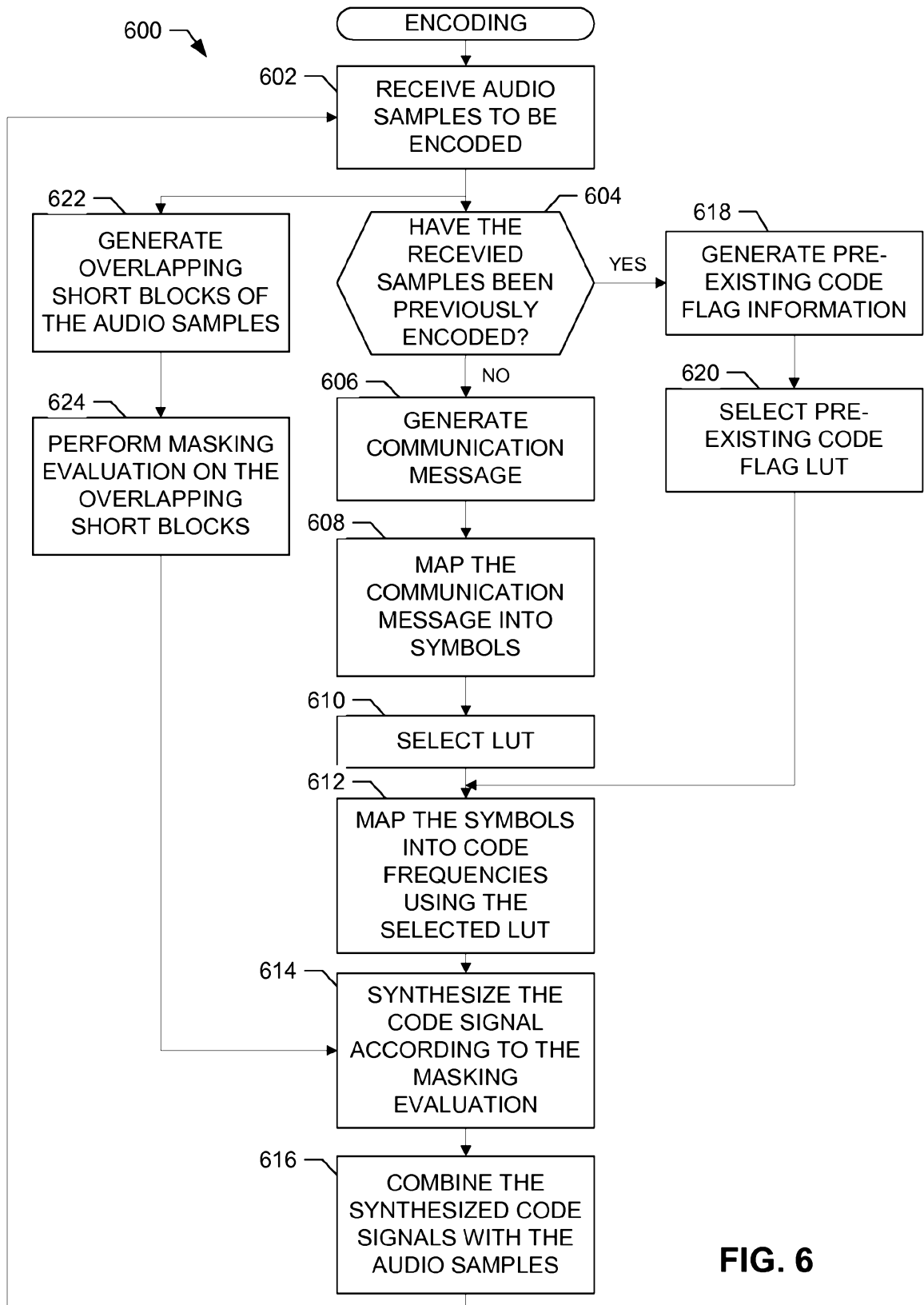

FIG. 6

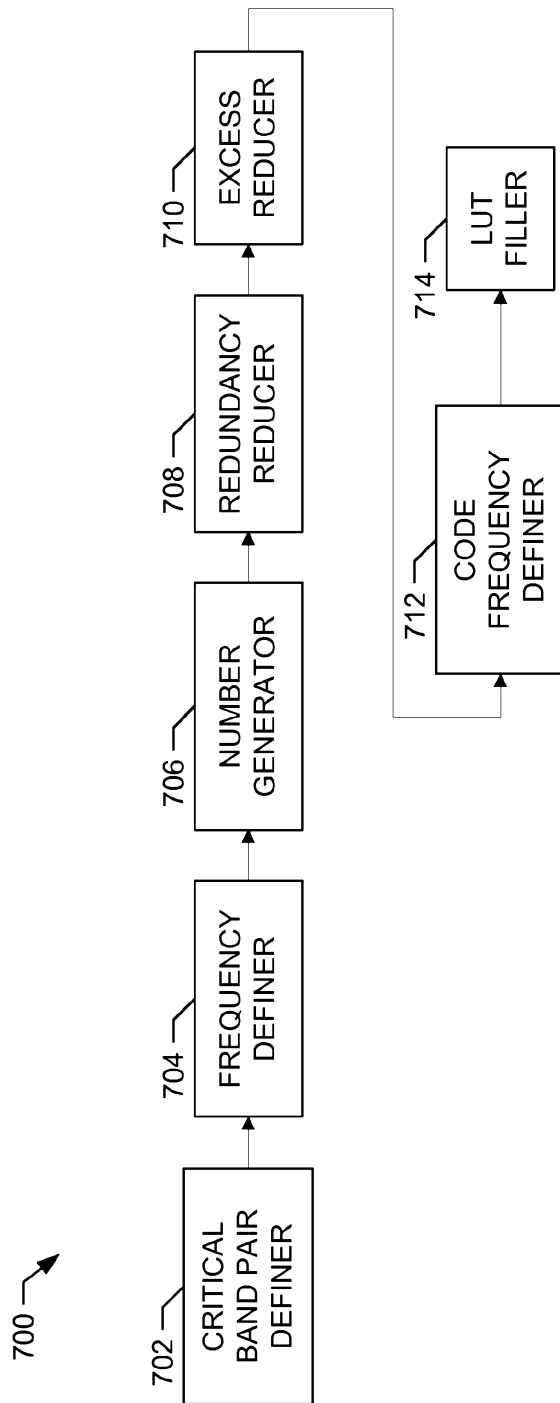

FIG. 7

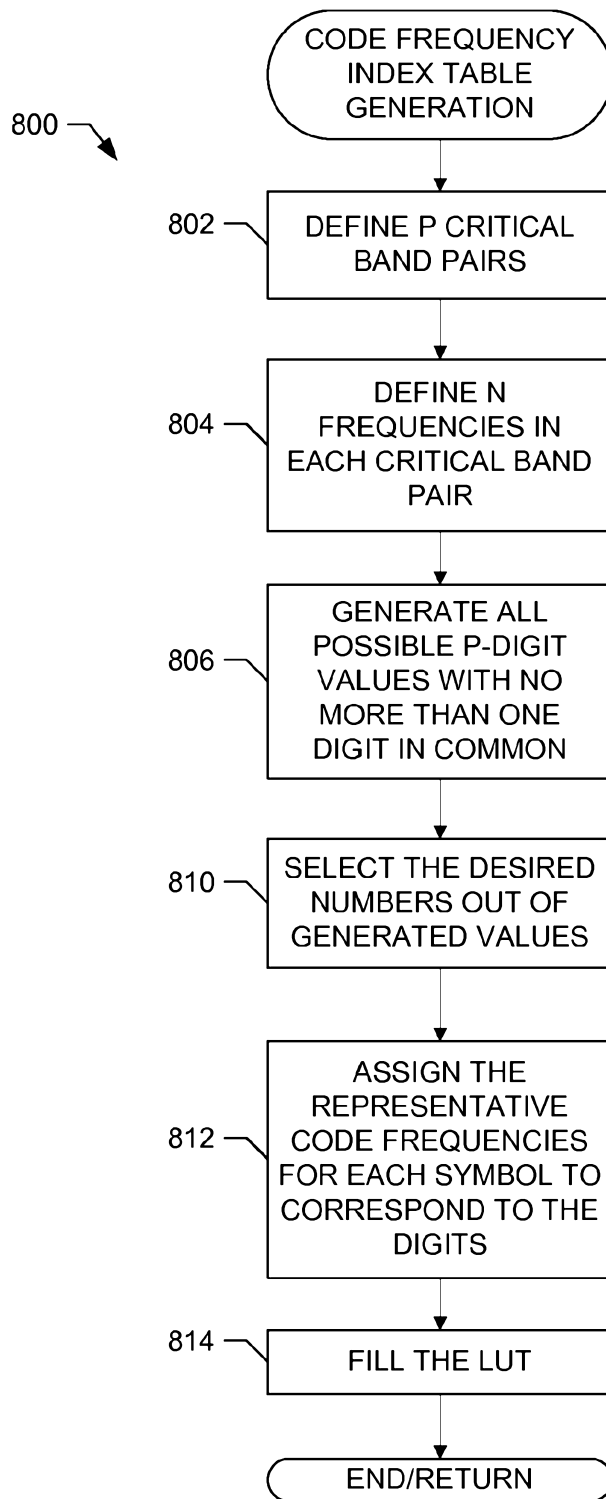

FIG. 8

900

902

904

906

AAC CRITICAL BAND INDEX	SHORT BLOCK (S12 SAMPLES) INDEX RANGE	LONG BLOCK (9216 SAMPLES) INDEX RANGE
5	10,11	180-216
6	12,13	217-252
7	14,15	253-288
8	16,17	289-324
9	18,19	325-360
10	20,21	361-396
11	22,23	397-432
12	24,25	433-468
13	26,27	469-504
14	28,29	505-540
15	30,31	541-576
16	32,33	577-612
17	34,35	613-648
17	36,37	649-684

FIG. 9



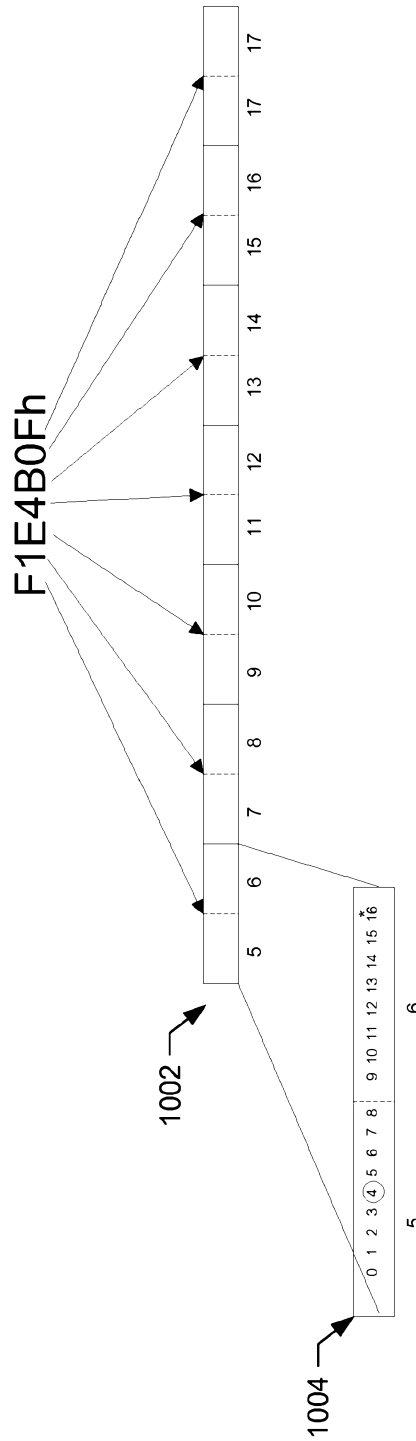

FIG. 10

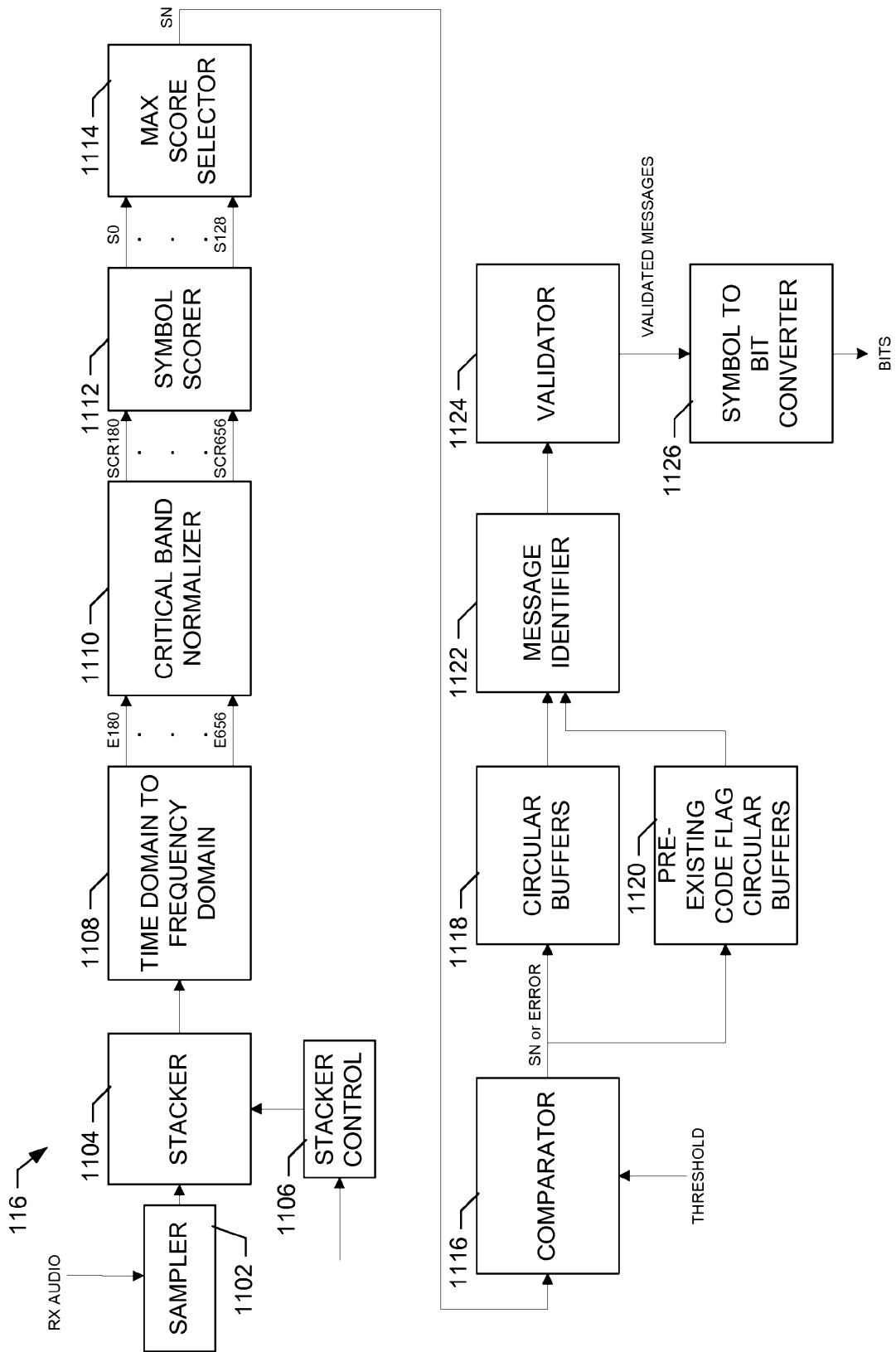

FIG. 11

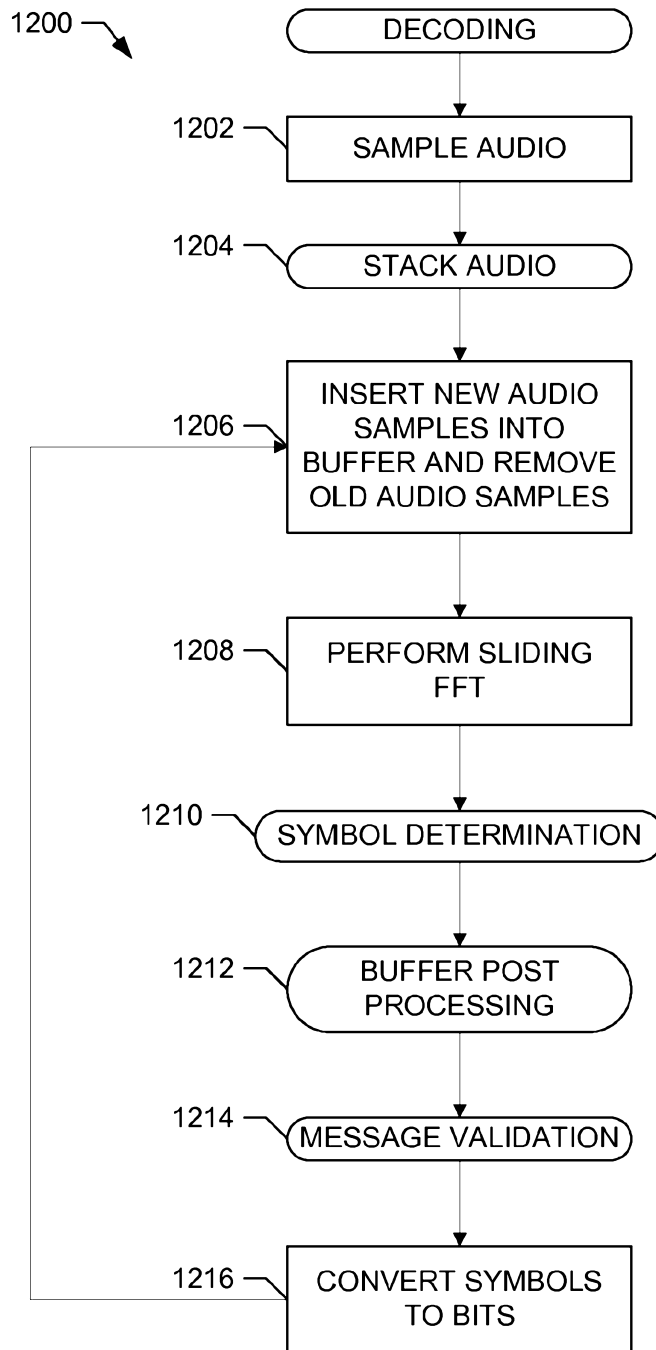

FIG. 12

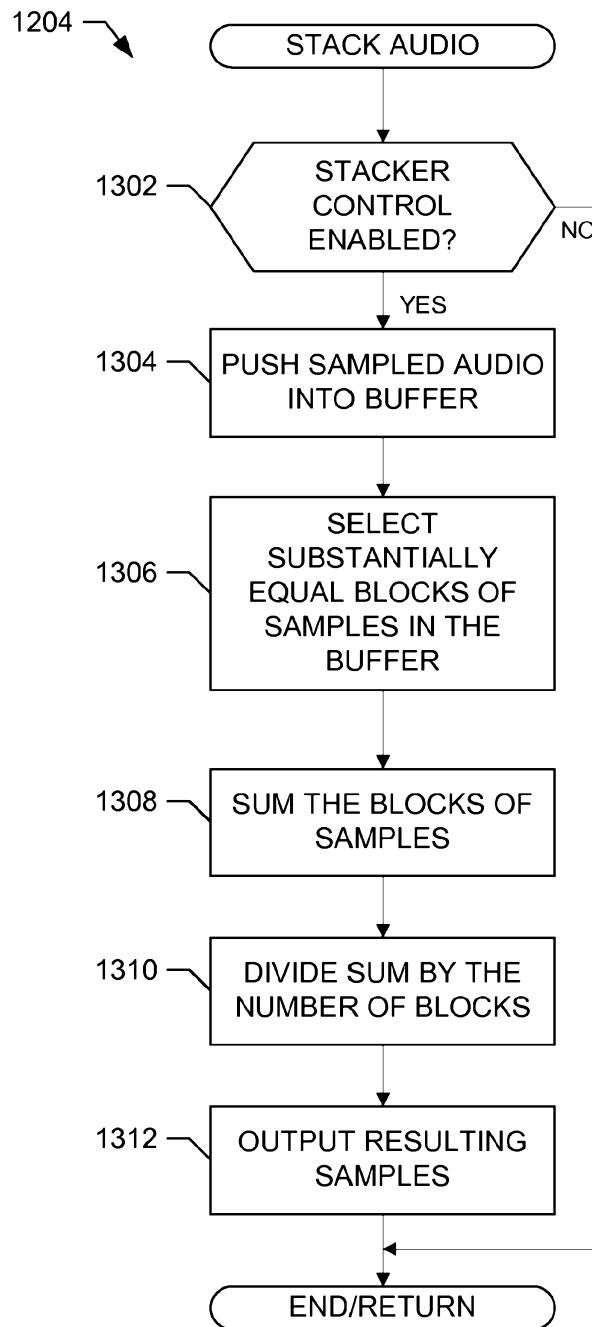

FIG. 13

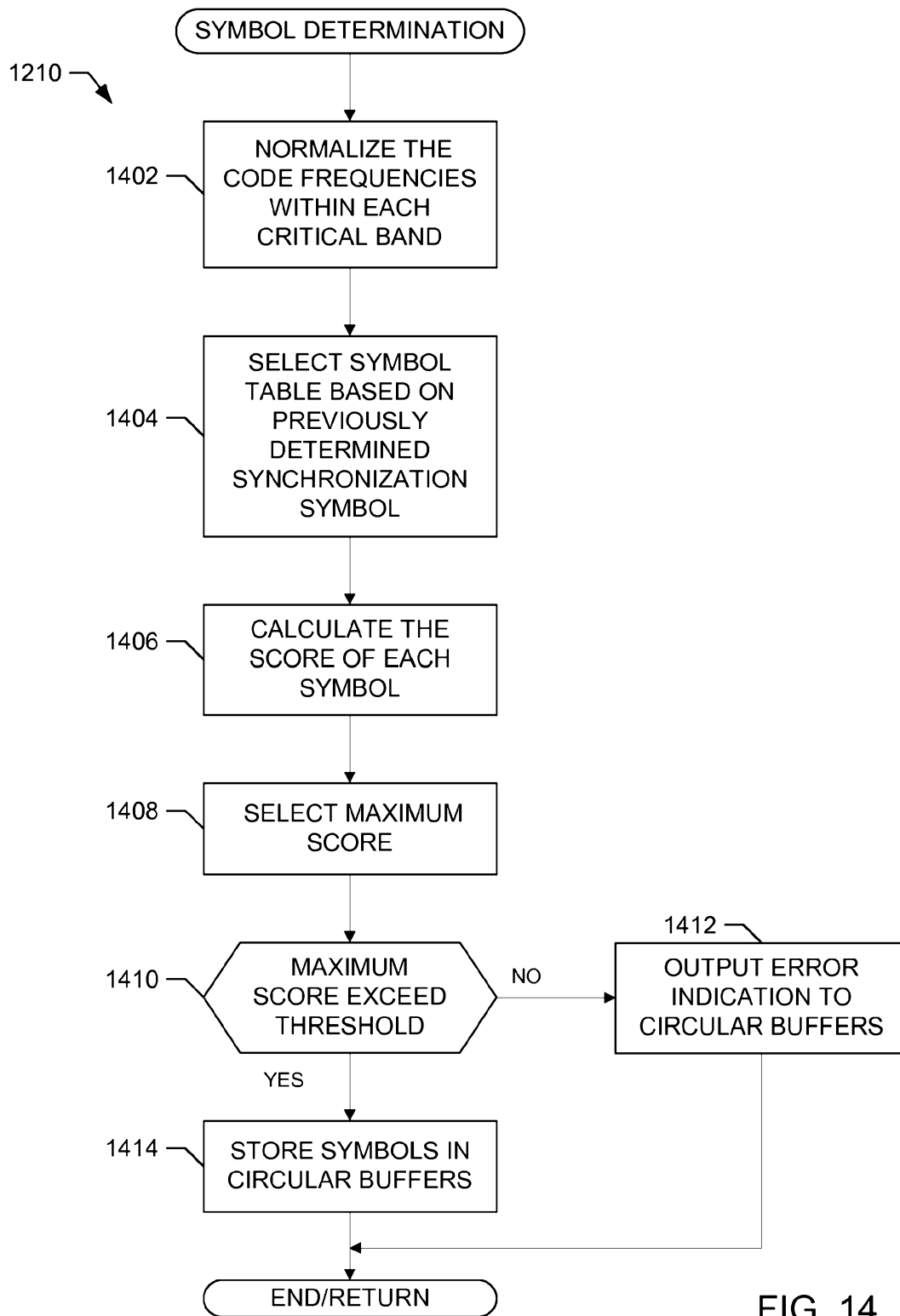

FIG. 14

1212 →

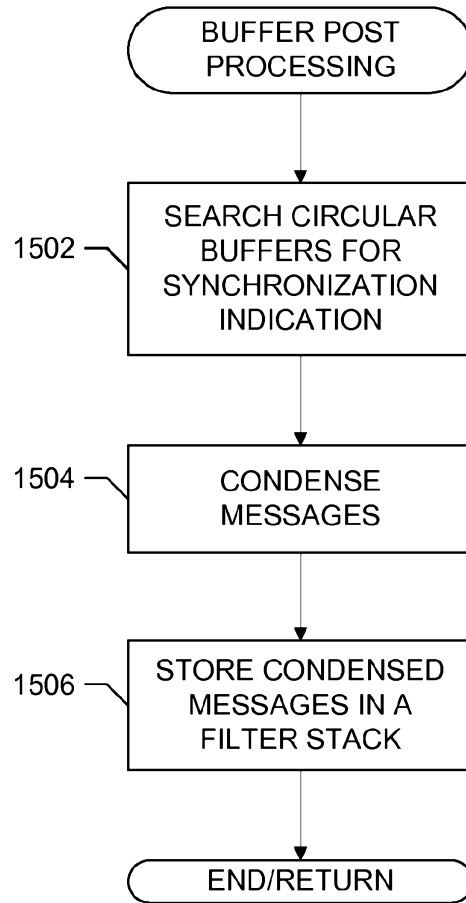

FIG. 15

CURRENT LOCATION

↓

SLIDING INDEX	0	1	2	3	4	5	6	7	SAMPLE INDEX
0									
3	128	128	32	128	35	128	128	128	35400
37	37	23	47	0	128	57	22	111	35672
38	37	23	47	0	128	57	22	111	35680
39	37	23	47	0	128	57	22	111	35688
191	128	128	128	128	128	128	128	128	36904

1118 ↗

FIG. 16

CURRENT LOCATION

↓

SLIDING INDEX	0	1	SAMPLE INDEX
0			
3	128	128	38472
37	254	68	38744
38	254	68	38752
39	254	68	38760
191	128	128	39976

1120 ↗

FIG. 17

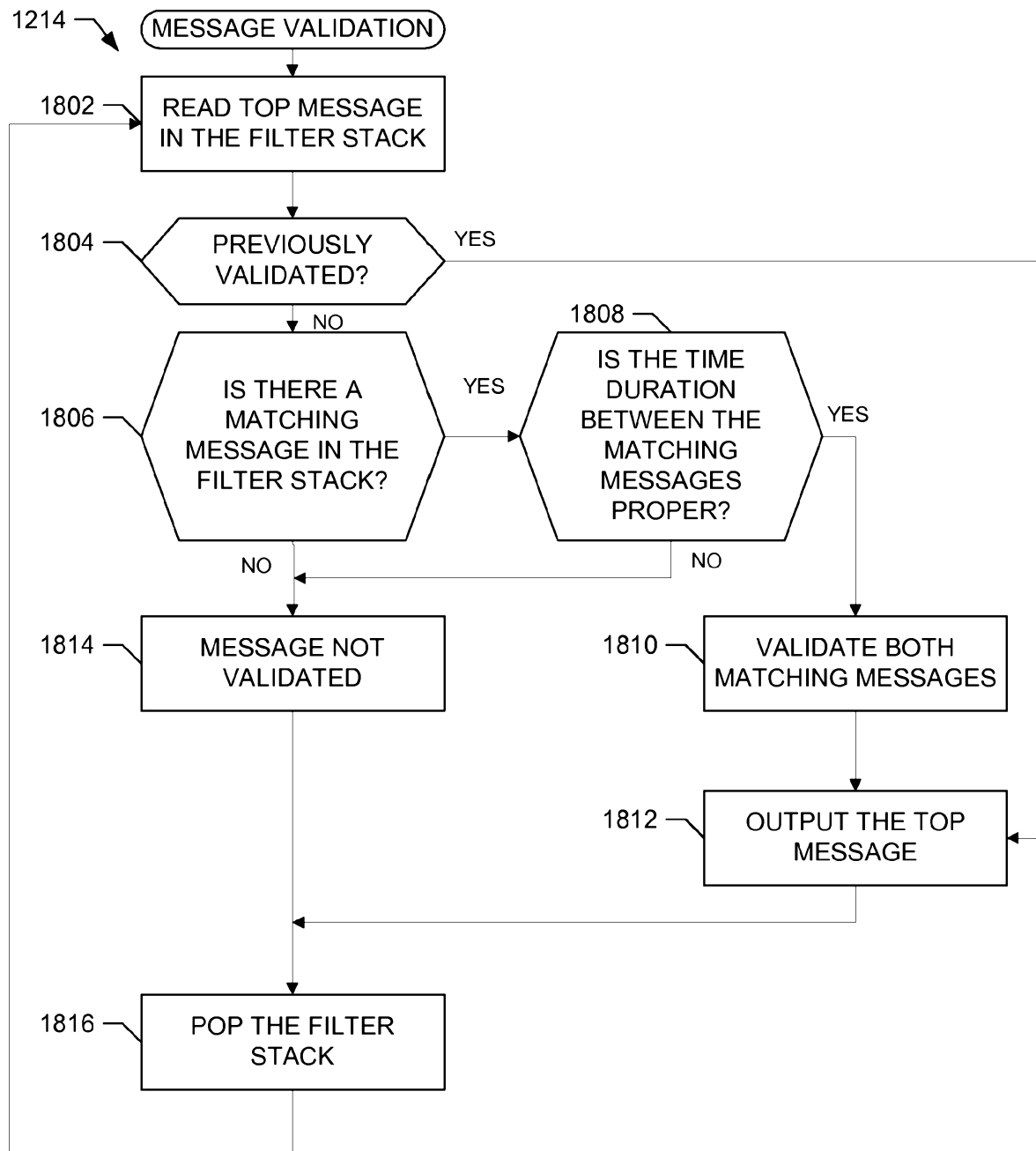

FIG. 18



MESSAGE INDEX	D0	D1	D2	D3	D4	D5	D6	SAMPLE INDEX	VALIDATION FLAG
M0	57	22	111	37	23	47	0	35680	VALIDATED
M7	57	13	111	37	23	33	3	67670	PARTIALLY VALIDATED

FIG. 19

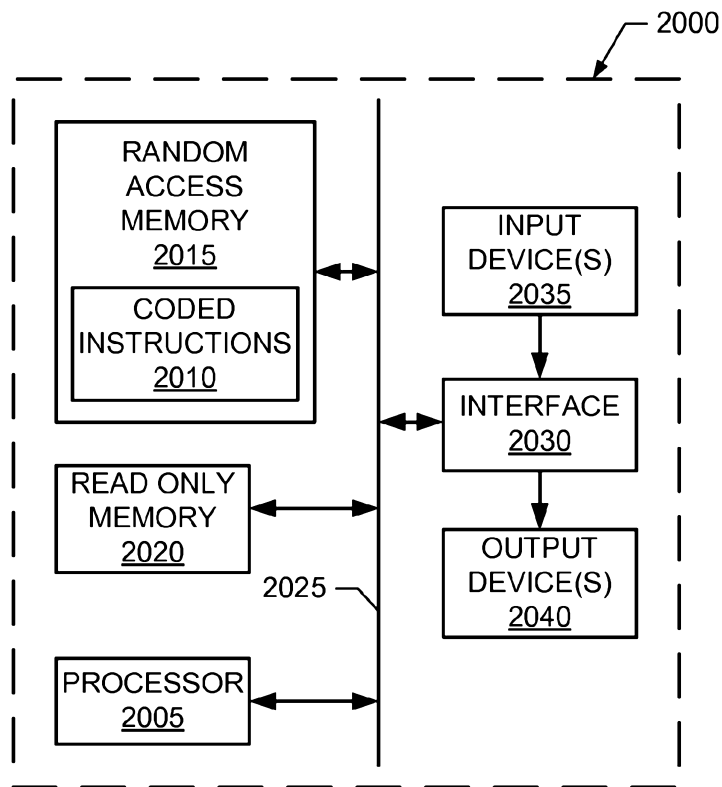

FIG. 20