



(22) Date de dépôt/Filing Date: 2014/02/21

(41) Mise à la disp. pub./Open to Public Insp.: 2015/08/21

(45) Date de délivrance/Issue Date: 2021/03/30

(51) Cl.Int./Int.Cl. *F28F 1/14* (2006.01),
C10G 9/20 (2006.01)

(72) Inventeurs/Inventors:
CROWE, JEFFREY STEPHEN, CA;
TAYLOR, MARK ANDREW, CA

(73) Propriétaire/Owner:
NOVA CHEMICALS CORPORATION, CA

(74) Agent: HAY, ROBERT

(54) Titre : TUBES DE CHAUDIERE A TIGES

(54) Title: PINNED FURNACE TUBES

(57) **Abrégé/Abstract:**

Furnace tubes for cracking hydrocarbons having a longitudinal array of pins having i) a maximum height from 0.5 - 1.3 cm; ii) a contact surface with the tube, having an area from 0.1%-10% of the tube external surface area iii) a uniform cross section along the length of the pin.(i.e. they are not tapered) ;and iv) a length to diameter ratio from 1.5:1 to 0.5:1 have an improved heat transfer over bare fins and reduced stress relative to a finned tube.

PINNED FURNACE TUBES

ABSTRACT OF THE DISCLOSURE

Furnace tubes for cracking hydrocarbons having a longitudinal array of pins having i) a maximum height from 0.5 – 1.3 cm; ii) a contact surface with the tube, having an area from 0.1%-10% of the tube external surface area iii) a uniform cross section along the length of the pin.(i.e. they are not tapered) ;and iv) a length to diameter ratio from 1.5:1 to 0.5:1 have an improved heat transfer over bare fins and reduced stress relative to a finned tube.

PINNED FURNACE TUBES

FIELD OF THE INVENTION

The present invention relates to the field of cracking paraffins to olefins and more particularly to pins (spines or studs) in a longitudinal array on the external surface of the process coil(s) in the radiant section of a cracking furnace. The pins can be spaced
5 apart in a regular pattern, or the spacing and length of the pins may vary to provide a profile to the array of pins. The profile of the array may be varied depending on the exposure of the coil to local radiation intensity in a furnace. A size of a single pin should be such that its base (a contact surface with a coil) should not exceed 10% of the coil
10 external surface area, and its height should not exceed 20% of the coil internal diameter.

These pins increase net transfer of radiant and convective heat from flame, combustion gases and surrounding furnace walls, into the external surface of the process coil.

15

BACKGROUND OF THE INVENTION

The field of heat exchanger designs is replete with applications of fins to improve the heat transfer. Typically this is heat transfer by forced convection mechanism. The heat transfer by forced convection takes place between a solid surface and fluid in motion, which may be gas or liquid, and it comprises the combined effects of
20 conduction and fluid flow. This type of heat transfer occurs in most of the conventional heating systems, either hot water or electric and industrial heat exchangers.

In the cracking process of a paraffin, such as ethane or naphtha, feed flows through a furnace coil (pipe) that is heated up to 1050°C inside the radiant section of a cracking furnace. At these temperatures, the feed undergoes a number of reactions,
25 including a free radical decomposition (cracking), reformation of a new unsaturated

product and the coproduction of hydrogen. These reactions occur over a very short period of time that corresponds to the feed residence time in a coil.

The interior of the radiant section of the furnace is lined with heat absorbing/radiating refractory and is heated, typically, by gas fired burners. The heat transfer within the furnace, between flame, combustion gases, refractory and the process coils is mostly by radiation, and also by forced convection.

There is a drive to improve the efficiency of cracking furnaces as this reduces process costs and greenhouse gas emissions. There have been two main approaches to improving efficiency; improving heat transfer to the furnace coils, i.e. from flame, combustion gases and refractory walls to the external surface of a process coil, and improving heat transfer within the coil, i.e. from the coil walls into the feed flowing inside the coil.

One of the methods representing the second approach, is the addition of internal fins to the inner walls of the furnace coil, to promote the “swirling” or mixing of the feed within the coil. This improves the convective heat transfer from the coil walls to the feed as the turbulence of the feed flow is increased and the heat transferring surface of the hot inner wall of the coil is increased as well.

United States patent 5,950,718 issued Sept. 14, 1999 to Sugitani et al., assigned to Kubota Corporation provides one example of this type of technology.

The papers “Three dimensional coupled simulation of furnaces and reactor tubes for the thermal cracking of hydrocarbons”, by T. Detemmerman, G.F. Froment, (Universiteit Gent, Krijgslaan 281, b9000 Gent – Belgium, mars-avri, 1998); and “Three dimensional simulation of high internally finned cracking coils for olefins production severity”, by Jjo de Saegher, T. Detemmerman, G.F. Froment, (Universiteit Gent1, Laboratorium voor Petrochemische Techniek, Krijgslaan 281, b-9000 Gent,

Belgium, 1998 provide a theoretical simulation of a cracking process in a coil which is internally finned with helicoidal and longitudinal fins (or rather ridges or bumps). The simulation results are verified by lab scale experiments, where hot air flows through such internally finned tubes. The papers conclude that the tube with internal helicoidal
5 fins performs better than with internal longitudinal fins and that the results for “a tube with internal helicoidal fins are in excellent agreement with industrial observations”. However, no experimental data are provided to support these conclusions. There is also no comparison made to the performance of a bare tube, with no internal ribs or fins. The authors agree that one potential disadvantage of such coils with internal fins
10 is that carbon deposits may build up on the fins, increasing the pressure drop through the tube.

United States patent 3,476,180 issued Nov. 4, 1969 to Straight Jr. et al., assigned to Esso Research and Engineering Company teaches tubes for use in the convection section of a cracking furnace. There are pins on the surface of the
15 downward face of the tubes in the convection section of the furnace. The pins are tightly packed and there is no dimension given for the length of the pin. In the convection section of the furnace the feed is relatively cool. The heat loss from the pins is low. In the radiant section of the furnace it is necessary to limit the length of the pin or the pin may become a radiator in effect dissipating heat from the tube. The patent
20 fails to suggest the subject matter of the present claims.

United States patent 5,437,247 issued Aug. 1, 1995 to Dubil et al., assigned to Exxon Research and Engineering Company teaches elongated plates pivotably mounted on at least one horizontal tube in a vertical row that is one row removed from the wall. When the plate is pivoted down it prevents channeling of the hot gases
25 through the convection section of the furnace (flue).

Canadian patent 1,309,841 issued August 25, 1988 to Fernandez – Baujin et al., assigned to Lummus Crest Inc., USA teaches putting “studs” (“pins”) on the external and internal surfaces of pyrolysis coils used in the radiant section of a cracker. The “pins are not arranged in longitudinal rows. Additionally the “pins” have a length from
5 0.5 to 0.75 inches. This is longer than the pin length of the present invention.

U.S. patent 6,250,340 issued June 26, 2001 to Jones et al., assigned to Doncasters PLC, teaches pipes for chemical reactions, such as furnace tubes having internal grooves

The report High Efficiency, Ultra low emissions, Integrated Process Heater by
10 TIAX LLC of June 19, 2006 to the U.S. Department of Energy, Golden Field Office discloses furnace tubes having studs 2 inches long and 0.5 inches in diameter. The studs were placed in longitudinal arrays on the side of the furnace tube facing the refractory wall. The studs have a length of 2 inches (page 3-26) . This teaches away from the subject matter of the present invention.

15 The present invention seeks to provide an enhanced heat transfer, comparable to that of a fin, while reducing the stress on the tube or pipe.

SUMMARY OF THE INVENTION

The present invention provides a tube for use in the radiant section of a furnace for cracking hydrocarbons to produce olefins having on its exterior surface a series of
20 pins in one or more linear arrays parallel to the longitudinal axis of the tube, said pins having:

- i) a height from 0.5 to 1.3 cm (0.25 inches to 0.5 inches) (e.g. from 3%-15% of the tube outer diameter of the tube);
- ii) a contact surface with the tube, having an area from 0.1%-10% of the
25 tube external surface area;

- iii) a uniform cross section along the length of the pin.(i.e. they are not tapered)
- iv) length to diameter ratio from 1.5:1 to 0.5:1

5 The present invention also provides the above tube wherein the distance between consecutive pins within a given linear array is from 0.1 to 5 times the diameter of the pin.

 The present invention also provides the above tube comprising from about 55 to
10 65 weight % of Ni; from about 20 to 10 weight % of Cr; from about 20 to 10 weight % of Co; and from about 5 to 9 weight % of Fe and the balance one or more of the trace elements.

 The present invention also provides the above tube further comprising from 0.2 up to 3 weight % of Mn; from 0.3 to 2 weight % of Si; less than 5 weight % of titanium,
15 niobium and all other trace metals; and carbon in an amount of less than 0.75 weight % the sum of the components adding up to 100 weight %.

 The present invention also provides the above tube, comprising from 40 to 65 weight % of Co; from 15 to 20 weight % of Cr; from 20 to 13 weight % of Ni; less than 4 weight % of Fe and the balance of one or more trace elements and up to 20 weight %
20 of W the sum of the components adding up to 100 weight %.

 The present invention also provides the above tube further comprising from 0.2 up to 3 weight % of Mn; from 0.3 to 2 weight % of Si; less than 5 weight % of titanium, niobium and all other trace metals; and carbon in an amount of less than 0.75 weight %.

The present invention also provides the above tube comprising from 20 to 38 weight % of chromium from 25 to 48, weight % of Ni.

The present invention also provides the above tube further comprising from 0.2 up to 3 weight % of Mn, from 0.3 to 2 weight % of Si; less than 5 weight % of titanium, niobium and all other trace metals; and carbon in an amount of less than 0.75 weight % and the balance substantially iron.

The present invention also provides the above tube wherein the cross section of the pin is round.

The present invention also provides the above tube wherein the cross section of the pin is quadrilateral.

The present invention also provides the above tube wherein the pins in a linear array are of uniform height.

The present invention also provides the above tube wherein the spacing between pins in a linear array is from 1 to 3 times the diameter of the pin.

The present invention also provides the above tube wherein the pins in a linear array are of different heights to provide a profile to the array.

The present invention also provides the above tube wherein at least part of the profile of an array is a taper or curve.

The present invention also provides the above tube wherein the central axis of the pin is at an angle from 90° to 60° relative to the external surface of the tube.

The present invention also provides a method for making a tube as described above by welding (preferably electrical) any stud shaped piece or strip to the surface of the tube and then cutting the stud shaped pieces at a desired length.

25

DETAILED DESCRIPTION

Other than in the operating examples or where otherwise indicated, all numbers or expressions referring to quantities of ingredients, reaction conditions, etc. used in the specification and claims are to be understood as modified in all instances by the term “about.” Accordingly, unless indicated to the contrary, the numerical parameters set forth in the following specification and attached claims are approximations that can vary depending upon the properties that the present invention desires to obtain. At the very least, and not as an attempt to limit the application of the doctrine of equivalents to the scope of the claims, each numerical parameter should at least be construed in light of the number of reported significant digits and by applying ordinary rounding techniques.

Notwithstanding that the numerical ranges and parameters setting forth the broad scope of the invention are approximations, the numerical values set forth in the specific examples are reported as precisely as possible. Any numerical values, however, inherently contain certain errors necessarily resulting from the standard deviation found in their respective testing measurements.

Also, it should be understood that any numerical range recited herein is intended to include all sub-ranges subsumed therein. For example, a range of “1 to 10” is intended to include all sub-ranges between and including the recited minimum value of 1 and the recited maximum value of 10; that is, having a minimum value equal to or greater than 1 and a maximum value of equal to or less than 10. Because the disclosed numerical ranges are continuous, they include every value between the minimum and maximum values. Unless expressly indicated otherwise, the various numerical ranges specified in this application are approximations.

All compositional ranges expressed herein are limited in total to and do not exceed 100 percent (volume percent or weight percent) in practice. Where multiple

components can be present in a composition, the sum of the maximum amounts of each component can exceed 100 percent, with the understanding that, and as those skilled in the art readily understand, that the amounts of the components actually used will conform to the maximum of 100 percent.

5 In the manufacture of ethylene, a feed typically selected from the group consisting of C₂₋₄ alkanes, and naphtha is fed into one or more furnace coils comprising straight tubes and "U" bends which pass through a cracking furnace. The furnace, schematically shown in Fig.1, includes two main parts: the convection section (1) where the feed (2) is initially preheated and initial cracking may occur, and the radiant
10 section (3) where most of the final cracking process takes place. The radiant section of the furnace comprises the inlet (4), located downstream of the convection section (1) which accounts for about half of the furnace radiant section and is sometimes referred to as a "cold" box, and the outlet (5) referred to as "hot" box. The feed flows through the process coil (6) which includes a long coil (7), suspended inside the inlet (4) and
15 outlet (5) radiant sections of the furnace. To increase the length of the coil and, thus, to allow for the adequate residence time of the feed inside both radiant parts of the furnace, the coil comprises multiple vertical straight tubes(7), referred to as "passes", inter-connected by return bends (8) (U-shaped elbows). As the feed flows through the coil passes in the inlet radiant furnace section (4), it is heated approximately to the
20 temperature at which cracking reactions begin and further cracking occurs. Next, the feed leaves the inlet radiant section and flows through the passes of the process coils in the furnace outlet radiant section (5). In this section, the feed is further heated, the cracking reaction is progressing, until the final products exit the coil (9) and are further treated (e.g. quenching and separation) and recovered downstream. In both parts of
25 the furnace radiant section, the feed is heated by flames and by combustion gases

generated by the burners (10) which are mounted on the furnace walls and on the furnace bottom. Heat transfer from combustion gases and flames to the processing coil (6) occurs predominantly by radiation and also, to a lesser extent, by the mechanism of forced convection. Flame and combustion gases heat not only the coils but also the furnace walls. The walls which are lined with a heat absorbing/radiating refractory, radiate heat on the coil, thus contributing to heating process of the flowing feed (2) as well.

If the efficiency of the heat transfer to the process coil in a furnace radiant section is maximized or just increased, fuel consumption by the burners can be reduced and, consequently, so are greenhouse gas emissions reduced. The increased efficiency of heat transfer in the radiant section provides also another possibility, such that the fuel consumption can be kept unchanged, but furnace capacity can be increased, i.e. higher feed flow rates can be cracked in the coil.

In accordance with the present invention, at least a portion of the external surface of one or more passes of the coil or furnace tube is augmented with relatively small pins or studs in a longitudinal array (e.g. along the major axis of the tube.)

The pins or studs may have any cross section such as a quadrilateral (e.g. rectangular or square) or round or oval. Typically the pin or stud will have a height (length) from about 3%-15% of the outer diameter of the tube, typically from 0.5 cm - 1.3 cm, generally from 0.5 cm to 1.2 cm, particularly from 0.8 cm to 1 cm. The base of the pin may cover from 0.1 to 10%, preferably from 1 to 8%, most preferably from 2 to 5% of the external surface area of the pipe or tube defined by the sum total contact area of all pins divided by the total surface area of the tube.

$$\text{area ratio (meter length)} = \frac{\text{Total pin base area}}{\text{Total tube external area}} = \frac{\# \frac{\text{pins}}{m} \times \frac{\pi OD_{pin}^2}{4}}{\pi OD_{tube} \times 1m}$$

The length to diameter ratio of the pin may be from 1.5:1 to 0.5:1, typically from 1:1 to 0.5:1. In a longitudinal array the spacing of the pins maybe from 5 D (diameter of the pin) to D/10, typically from 0.5D to 5 D, preferably from 1 D to 3 D. However, it should be noted that in any array the spacing of the pins need not be uniform. For example the spacing could be wider at the middle of the tube and closer towards the end of the tube. What is more desirable is to increase the heat flux into the tube. While generally it is easiest if the central axis of the pins are perpendicular to the surface of the tube they may be at an angle from 90° to 60 ° relative to the surface of the tube. Typically the pins or studs have a uniform cross section along their length and are not tapered.

The longitudinal arrays are be radially spaced apart along the surface of the tube by an angle from 30 ° to 180 ° so there may be from 12 to 2 longitudinal arrays on a pipe, typically from 2 to 6 longitudinal arrays are used (e.g. radially spaced from 180 ° to 60 °). The arrays need not be circularly parallel. That is adjacent arrays could be offset so that the pins in one array match spaces in an adjacent array. Additionally an array need not be uniform in height along its entire length. The array could have one or more section of reduced height. For example the array could reduce from a maximum height in the middle to a minimum height at each end (an inward facing parabola) or vice versa (an out ward facing parabola) so that the array has a profile.

The location and arrangement of the arrays of pins should maximize radiant and convective heat flux into the coil. The location of the arrays and spacing and heights of the pins need not be uniform.

In designing the pins care must be taken so that they absorb more radiant energy than they may radiate. This may be restated as the transfer of heat through the base of the pin into the coil must exceed that transferred to the equivalent surface on a

bare coil at the same operational conditions. If the concentrations of the pins become excessive and if their geometry (height and diameter) is not selected properly, they may start to reduce heat transfer, due to thermal effects of excessive conductive resistance, which defeats the purpose of the invention. The properly designed and manufactured pins will increase net radiation and convective heat transferred to a coil from surrounding flowing combustion gasses, flame and furnace refractory. Their positive impact on radiation heat transfer is not only because more heat can be absorbed through the increased coil external surface so the contact area between combustion gases and coil is increased, but also because the relative heat loss through the radiating coil surface is reduced, as the coil surface is not smooth any more.

Accordingly, as a pin radiates energy to its surroundings, part of this energy is delivered to and captured by other pins, thus it is re-directed back to the coil surface. The pins will also increase the convective heat transfer to a coil, due to increase in coil external surface that is in contact with flowing combustion gas, but also by increasing turbulence along the coil surface and by reducing the thickness of a boundary layer .

The pins may comprise up to 5%-25%, preferably from 5% to 20% of the weight of the coil pass (7). One of the limiting issues to consider is the creep of the coil pass (7) given the additional weight of the pins. However, it should be noted an array of pins will place less stress on the coil pass than a continuous fin (e.g. there is less mass to support). This may also affect the location and concentration of the pins. It may reduce creep if there are more pins on the upper surface of the pass. Preferably, the pins have the same composition as the material of the pass (7) of the radiant coil.

In one embodiment the tube may be manufactured by welding (electrically) any stud shaped strip (e.g. a wire or a welding rod) to the surface of the tube at a desired location and then cutting the strip at the desired length.

The pass of the coil may be a tube of a stainless steel which may be selected from the group consisting of wrought stainless, austentic stainless steel and HP, HT, HU, HW and HX stainless steel, heat resistant steel, and nickel based alloys. The coil pass may be a high strength low alloy steel (HSLA); high strength structural steel or
5 ultra high strength steel. The classification and composition of such steels are known to those skilled in the art.

In one embodiment the stainless steel, preferably heat resistant stainless steel typically comprises from 13 to 50, preferably 20 to 50, most preferably from 20 to 38 weight % of chromium. The stainless steel may further comprise from 20 to 50,
10 preferably from 25 to 50 most preferably from 25 to 48, desirably from about 30 to 45 weight % of Ni. The balance of the stainless steel may be substantially iron.

The present invention may also be used with nickel and/or cobalt based extreme austentic high temperature alloys (HTAs). Typically the alloys comprise a major amount of nickel or cobalt. Typically the high temperature nickel based alloys comprise
15 from about 50 to 70, preferably from about 55 to 65 weight % of Ni; from about 20 to 10 weight % of Cr; from about 20 to 10 weight % of Co; and from about 5 to 9 weight % of Fe and the balance one or more of the trace elements noted below to bring the composition up to 100 weight %. Typically the high temperature cobalt based alloys
20 comprise from 40 to 65 weight % of Co; from 15 to 20 weight % of Cr; from 20 to 13 weight % of Ni; less than 4 weight % of Fe and the balance one or more trace elements as set out below and up to 20 weight % of W. The sum of the components adding up to 100 weight %.

In some embodiments of the invention the steel may further comprise a number of trace elements including at least 0.2 weight %, up to 3 weight % typically 1.0 weight
25 %, up to 2.5 weight % preferably not more than 2 weight % of manganese; from 0.3 to

2, preferably 0.8 to 1.6 typically less than 1.9 weight % of Si; less than 3, typically less than 2 weight % of titanium, niobium (typically less than 2.0, preferably less than 1.5 weight % of niobium) and all other trace metals; and carbon in an amount of less than 2.0 weight %. The trace elements are present in amounts so that the composition of the steel totals 100 weight %.

BRIEF DESCRIPTION OF THE DRAWINGS

Figure 1 is a schematic drawing of an ethylene cracker.

Figure 2 shows the geometry of a single longitudinal vertical fin with rectangular cross section.

Figure 3 shows an axial fin temperature distribution with increasing height of the fin.

Figure 4 shows a half cross section of bare tube (a), axial finned tube (b), and pinned tube (c).

EXAMPLE

The present invention will now be illustrated by the following non limiting example.

Example 1

A finite element model of the ethylene 1 furnace tubes was performed in ANSYS Mechanical 14.0. This is a commercial finite element analysis (FEA) software used to create numerical models for stress/strain and heat transfer analysis.

Prior to performing a FEA analysis a heat transfer model of a rectangular fin (Figure 2) was created for a one-dimensional heat distribution. The net heat conducted through the fin is equal to heat transferred to the fin external surface from surroundings,

$$Q_{x+dx} - Q_x = Q_{\alpha} ;$$

$$\frac{d}{dx} \left(A \frac{d\Theta}{dx} \right) = \frac{\alpha O}{\lambda} \Theta$$

Where $\Theta = t_g - t_x$ - the temperature difference between combustion gases, t_g , and local temperature in the fin, t_x , at location x ($0 \leq x \leq L_z$)

$O = 2(L_s + L_h)$ - the perimeter of the cross section of the rectangular fin,

λ - thermal conductivity of the fin material,

α - total heat transfer coefficient ($\alpha = \alpha_{rad} + \alpha_{conv}$)

From the above equation.

$$\frac{d^2 \Theta}{dx^2} = B^2 \Theta$$

where:

$$B \equiv \sqrt{\frac{\alpha O}{\lambda A}}$$

The general solution of this equation takes the form:

$$\Theta_x = C_1 e^{Bx} + C_2 e^{-Bx}$$

where the constants C_1 and C_2 are determined from two boundary conditions:

$$\text{for } x=0 \quad \Theta = \Theta_p = C_1 + C_2$$

$$\text{for } x=L_z \quad \Theta = \Theta_k = C_1 e^{BL_z} + C_2 e^{-BL_z}$$

and, $Q_\lambda = Q_\alpha = -A\lambda \left(\frac{d\Theta}{dx} \right)_{x=L_z} = A\alpha\Theta_k$

So, after calculating C_1 and C_2 , the temperature distribution in the fin takes the form:

$$\Theta_x = \Theta_p = \frac{\cosh[B(L_z - x)] + \frac{\alpha}{B\lambda} \sinh[B(L_z - x)]}{\cosh BL_z + \frac{\alpha}{B\lambda} \sinh BL_z}$$

This temperature distribution is shown in Figure 3 for a base temperature of 900°C which was used for generating temperature loads on the axial finned tube.

A static structural FEA was performed on three different furnace tubes; a bare tube, an axial finned tube, and a pinned tube. Half models were created with symmetric boundary conditions. A cross section of each of the tubes is shown in Figure 4(a)(bare tube), Figure 4(b)(axial finned tube), and Figure 4(c)(pinned tube). The temperature distribution described above was applied to the external surface of the finned and pinned tube. Since the above heat transfer analysis was not performed for a pinned tube, the external surfaces of the pinned tube were assumed to follow the same distribution. An average process temperature of approximately 750°C and an average convective heat transfer coefficient of 998W/m²K were used to define the thermal boundary condition on the inner surface of the tube. Both gravity and an internal tube pressure of 0.336MPa were also applied to the furnace tube model. The temperature distribution described above was determined for an axial finned tube and the assumption was made that the distribution would be similar in a pinned tube.

Equivalent stress (MPa) of the external and internal surfaces was modeled for each of the bare tube, the axial finned tube, and the pinned tube. The equivalent stress for the bare tube was found to be 41.6 MPa (external) and 49.8 MPa (internal). The equivalent stress for the axial finned tube was found to be 93.9 MPa (external) and 129.7 MPa (internal). Finally, the equivalent stress for the pinned tube was found to be 41.8 MPa (internal) and 52.6 MPa (external). Furthermore, equivalent stress of the fin portion of the axially finned tube was found to be 302.4 MPa, while the pin portion of the pinned tube demonstrated an equivalent stress lower than 7.93 MPa. The results demonstrate that unlike axially finned tubes, the pinned tube described herein is in a state of stress that approximates a bare tube. Axial finned tubes are in a much higher

state of stress than the bare tube and the pinned tube. Finally, the stress seen in the fin portion of the axially finned tube is not seen in the pin portion of the pin tube.

The advantage of the pinned tube is that it is not constrained in any direction and is free to expand. There is a slight stress concentration at the base of the pin; however the overall state of stress is much lower than that of the axial finned tube. The overall state of stress in the furnace tube is comparable to that of a bare tube. However, there is an increase in heat transfer in the pinned tube over the bare tube.

The embodiments of the invention in which an exclusive property or privilege is claimed are defined as follows:

1. A tube for use in a radiant section of a furnace for cracking hydrocarbons to produce olefins having on its exterior surface a series of pins in one or more linear arrays parallel to a longitudinal axis of the tube, said pins having:
 - i) a maximum height from 0.8 cm to 1 cm;
 - ii) a contact surface with the tube, having an area from 0.1%-10% of the tube external surface area;
 - iii) a uniform cross section along the length of the pin;
 - iv) a length to diameter ratio from 1.5:1 to 0.5:1;
 - v) a distance between consecutive pins within a given linear array is from 0.1 to 5 times a diameter of the pin; and
 - vi) from 2 to 6 longitudinal arrays of pins radially spaced from 60° to 180° apart.

2. The tube according to claim 1, wherein the pins have a maximum length from 3%-15% of the tube outer diameter.

3. The tube according to claim 2, comprising from about 55 to 65 weight % of Ni; from about 20 to 10 weight % of Cr; from about 20 to 10 weight % of Co; and from about 5 to 9 weight % of Fe and the balance one or more of the trace elements.

4. The tube according to claim 3, further comprising from 0.2 up to 3 weight % of Mn; from 0.3 to 2 weight % of Si; less than 5 weight % of titanium, niobium and all other

trace metals; and carbon in an amount of less than 0.75 weight % the sum of the components adding up to 100 weight %.

5. The tube according to claim 2, comprising from 40 to 65 weight % of Co; from 15 to 20 weight % of Cr; from 20 to 13 weight % of Ni; less than 4 weight % of Fe and the balance of one or more trace elements and up to 20 weight % of W the sum of the components adding up to 100 weight %.

6. The tube according to claim 5, further comprising from 0.2 up to 3 weight % of Mn; from 0.3 to 2 weight % of Si; less than 5 weight % of titanium, niobium and all other trace metals; and carbon in an amount of less than 0.75 weight %.

7. The tube according to claim 2, comprising from 20 to 38 weight % of chromium from 25 to 48, weight % of Ni.

8. The tube according to claim 7, further comprising from 0.2 up to 3 weight % of Mn, from 0.3 to 2 weight % of Si; less than 5 weight % of titanium, niobium and all other trace metals; and carbon in an amount of less than 0.75 weight % and the balance substantially iron.

9. The tube according to claim 3, wherein the cross section of the pin is round.

10. The tube according to claim 4, wherein the cross section of the pin is round.

11. The tube according to claim 5, wherein the cross section of the pin is round.

12. The tube according to claim 7, wherein the cross section of the pin is round.
13. The tube according to claim 3, wherein the cross section of the pin is quadrilateral.
14. The tube according to claim 4, wherein the cross section of the pin is quadrilateral.
15. The tube according to claim 5, wherein the cross section of the pin is quadrilateral.
16. The tube according to claim 7, wherein the cross section of the pin is quadrilateral.
17. The tube according to claim 2, wherein the pins in a linear array are of uniform height.
18. The tube according to claim 2, wherein the spacing between pins in a linear array is from 0.5 to 5 times the diameter of the pin.
19. The tube according to claim 2, wherein the pins in a linear array are of different heights to provide a profile to the array.
20. The tube according to claim 19, wherein at least part of the profile is a taper.

21. The tube according to claim 2, where in the central axis of the pin is at an angle from 90° to 60° relative to the external surface of the tube.

22. A method for making a tube according to claim 1, electrical welding a strip of any stud shaped material to the surface of the tube and then cutting the strip at the desired length.

Figure 1

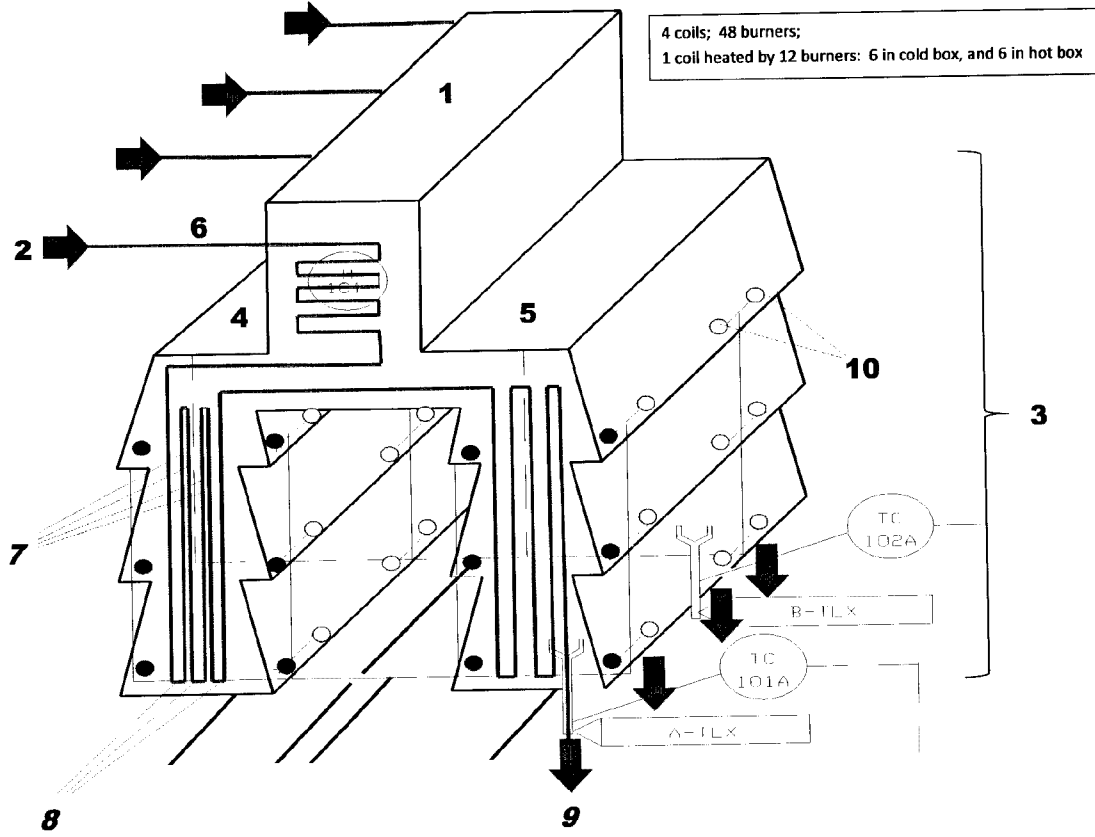

Figure 2

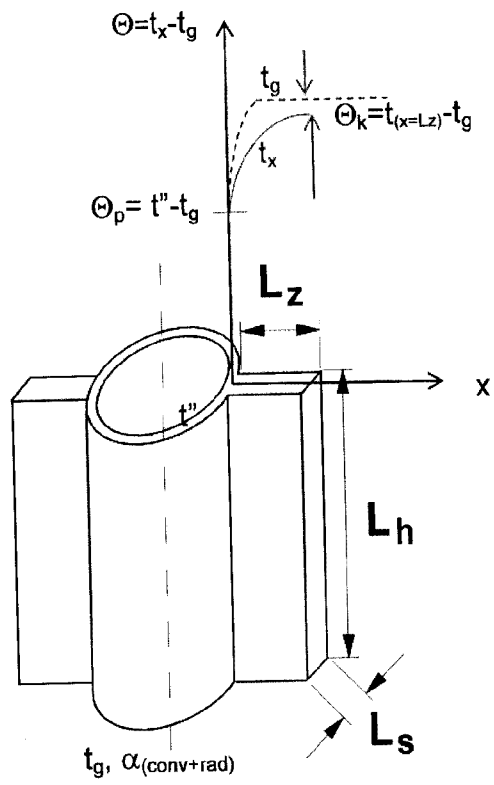

Figure 3

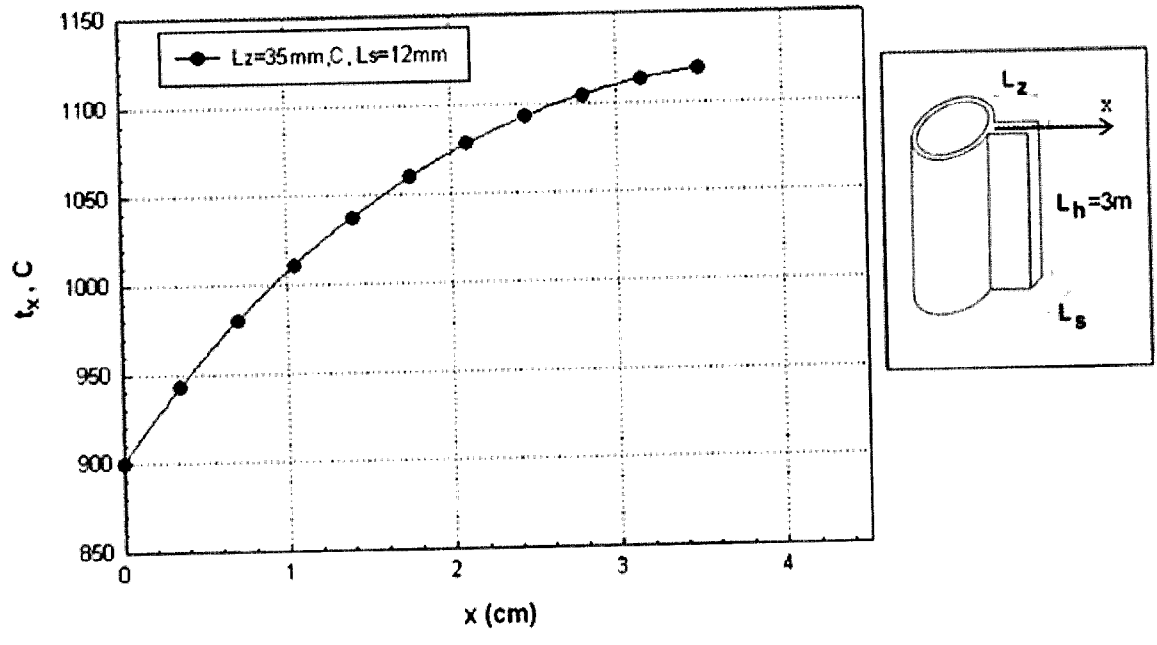

Figure 4

