



Europäisches Patentamt  
European Patent Office  
Office européen des brevets



Publication number: **0 449 643 B1**

12

## EUROPEAN PATENT SPECIFICATION

- 49 Date of publication of patent specification: **31.05.95** 51 Int. Cl.<sup>8</sup>: **B65D 81/34**  
21 Application number: **91302784.3**  
22 Date of filing: **28.03.91**

54 **Food package.**

30 Priority: **30.03.90 GB 9007262**  
**24.09.90 GB 9020726**

43 Date of publication of application:  
**02.10.91 Bulletin 91/40**

45 Publication of the grant of the patent:  
**31.05.95 Bulletin 95/22**

84 Designated Contracting States:  
**AT BE CH DE DK ES FR GB GR IT LI LU NL SE**

56 References cited:  
**EP-A- 0 200 220**

73 Proprietor: **DALGETY SPILLERS FOODS LIMITED**

**19 Hanover Square**  
**London W1R 9DA (GB)**

72 Inventor: **Natt, Anthony Robert**  
**14 St Wilfrids Close,**  
**Kibworth Beauchamp**  
**Leicestershire, LE8 0PY (GB)**

Inventor: **Proffitt, James Adrian**  
**26 Latimer Crescent,**  
**Market Harborough**  
**Leicestershire, LE16 8AP (GB)**

Inventor: **Boothman, Paul Lister**  
**The White House,**  
**Main Street**  
**Peatling Parva,**  
**Leicestershire, LE17 5OA (GB)**

74 Representative: **Greenwood, John David et al**  
**Graham Watt & Co.**

**Riverhead**  
**Sevenoaks**  
**Kent TN13 2BN (GB)**

**EP 0 449 643 B1**

Note: Within nine months from the publication of the mention of the grant of the European patent, any person may give notice to the European Patent Office of opposition to the European patent granted. Notice of opposition shall be filed in a written reasoned statement. It shall not be deemed to have been filed until the opposition fee has been paid (Art. 99(1) European patent convention).

## Description

The present invention relates to the packaging of pre-cooked foods intended to be reheated in a microwave oven.

EP-A-0,200,220 discloses the features of the preamble of claim 1. It shows a container packed with instant noodles comprising a container body, a lid for covering the upper opening of the container body, dehydrated instant noodles and a second container, the noodles and the second container being accommodated in the container and suitable to be heated in a microwave oven.

The present invention is characterised by the characterising features of claim 1.

In particular the present invention provides a food product comprising first and second nested containers, the first container being a closed container formed of a non-metallic (e.g. plastics) material capable of withstanding retorting conditions, the said first container being in the form of a dish and containing a food which has been subjected to cooking by retorting in the container; the second container being a closed container formed of a non-metallic (e.g. plastics) material capable of withstanding temperatures generated in a microwave oven, the said second container containing a pre-cooked dehydrated foodstuff.

Suitably the first and second containers are in the form of a pair of nested bowls. Thus, for example, the innermost of the two nested bowls may rest inside the outermost bowl such that the floor of the inner bowl is spaced above the floor of the outer bowl to define a chamber therebetween in which is located the pre-cooked dehydrated foodstuff. In order to support the inner bowl thus, the outer bowl may be provided with recesses or projections which engage complementary surfaces on the inner bowl. In one embodiment, the outer bowl may be provided with a rim having recesses therein which engage complementary projections on the rim of the inner container, the inner bowl suitably being supported such that the upper surface of its rim is substantially flush with the upper surface of the rim of the outer bowl.

The pre-cooked dehydrated foodstuff typically is selected from instant rice, instant pasta, instant potato, instant pulses and instant fruit and vegetables. The term "instant" as used herein means that the foodstuff has been pre-cooked and then dehydrated such that when added to cold water and exposed to microwave heating, it rapidly rehydrates to afford a fully hydrated cooked product. Preferably, when exposed to microwave heating, the dehydrated foodstuff is fully rehydrated in less than about 8 minutes, for example less than 6 minutes. Most preferably it is fully rehydrated within about 4.5 minutes. A suitable grade of instant pasta may

be obtained from, for example, Soubry of Roeselare, Belgium, and a suitable grade of instant rice may be obtained from, for example, Riviana of Houston, Texas.

5 Herbs and spices may also be included in the foodstuff contained within the outer bowl, for example in dehydrated form where appropriate.

10 The inner container must be capable of withstanding both retorting and microwave heating conditions and must be configured so as to allow efficient heating of the food contained therein in the microwave oven. The inner container should have good barrier properties to both air and water vapour. It may be made from, for example, a single or  
15 multilayer food grade plastics material. Where such plastics material is gas-, or moisture-permeable, a barrier membrane is provided which may, for example, be sandwiched between inner and outer layers of the plastics material. The barrier mem-  
20 brane can be formed from plastics such as polyvinylidene chloride or ethylene vinyl alcohol polymer.

25 The inner container will be sealed at its open end, prior to the food therein being retorted, by means of a lid which can be formed, for example, from a metal/plastics laminate material or a plastics material, either of which must have moisture- and gas-barrier properties. Typically, the lid is sealed to the container by means of the "TOR" closing process described in GB-A-2067157. Thus, the con-  
30 tainer may be filled such that a small headspace volume is left and may then be introduced into a vacuum chamber along with a lid web, a vacuum being applied both above and below a lid web. A profiled heated sealing head is then urged against the lid web and towards a rim or flange on the  
35 container thereby to seal the lid web against the rim or flange. Compressed air is then blown against the surface of the lid and the excess webbing trimmed from the periphery of the rim. The integ-  
40 rity of the resulting seal between the inner container and its lid is important for maintaining the commercial sterility of the food contained within. The gas- and moisture-barrier properties of the  
45 inner container and its lid are important for maintaining the quality of the food contained within.

50 The inner container can contain a wide variety of wet retorted foodstuffs and since the provision of such retorted foodstuffs is known, details of their precise nature and identity will not be provided here. However, it has been found that the quality of the texture of substantially carbohydrate-based  
55 foods such as rice and pasta is impaired by subjecting such foods to cooking by the retorting process, and then storing prior to reheating in a microwave oven. It is thus preferred that the inner container does not contain such substantially carbohydrate-based foods.

Typically, the viscosity of the wet retorted foodstuff in is the range 100 - 10,000 centipoise (preferably greater than 1750 centipoise, e.g. up to 5000 centipoise) at 20 °C as measured by a Brookfield viscometer (RVT) fitted with a spindle number 4 at a speed of 20 r.p.m.

In general, the food contained within the first or inner container has a water content equivalent to less than one hundred percent of the water absorption capacity of the dehydrated food in the second or outer container.

The outermost bowl can be constructed from the same material as the inner bowl but need not be, since it is not required to withstand such rigorous temperature conditions as the inner bowl. Typically it is formed from a food grade plastics material such as polyethylene, polypropylene or polystyrene. The polypropylene can be a "filled" polypropylene, ie. it can contain certain fillers such as talc, mica and pigments.

The outer bowl does not need to be sealed by a closure which has gas-and moisture-barrier properties and hence the manner in which the open end of the bowl is closed is not especially critical. However, in one preferred embodiment, the bowl is closed by means of a peelable plastics lid.

In general the amount of dehydrated food in the outer bowl and the size of the outer bowl are chosen such that the dehydrated food therein, when fully hydrated, will fill at least half of the volume of the container.

Typically the ratio of the internal volume of the outer bowl to the internal volume of the inner bowl is in the range 2:1 to 4:1, for example 2:1 to 2.5:1.

The precise volume ratio required will depend upon the nature of the food in the outer bowl. Thus, for example, when the food is a more compact substance such as rice, the volume ratio typically is approximately 2.2:1 whereas if the food is a less compact substance such as pasta, the volume ratio is usually somewhat larger, for example approximately 2.4:1. Typical internal volumes for the inner bowl are in the range 100cm<sup>3</sup> to 500cm<sup>3</sup> for example 200cm<sup>3</sup> to 300cm<sup>3</sup>, eg. approximately 250cm<sup>3</sup>, whereas typical volumes for the outer bowl are in the range 400cm<sup>3</sup> to 2000cm<sup>3</sup>, for example 500cm<sup>3</sup> to 700cm<sup>3</sup>, eg. approximately 550cm<sup>3</sup> to 600cm<sup>3</sup>.

The thickness of the walls of the containers will be generally of the order of 0.3mm to 1.2mm, and may be reinforced at certain points by means of wall portions having a greater thickness. For example, the outer bowl may have a wall thickness of approximately 0.5mm and the inner bowl may have a wall thickness of approximately 0.75mm.

The walls and floor of the inner container serve to divide the interior of the outer container into two chambers, a first chamber which is bounded by the outer surface of the inner container and the inner

surface of the outer container and a second chamber which is bounded by the inner surface of the inner container. The ratio of the volume of the first chamber to the second chamber suitably is in the range from 2:1 to 1:2, for example 1:1.5 to 1.5:1, preferably 1.5:1 to 1:1.

In one preferred embodiment, the nested containers may be provided with conduit means to permit liquid to be poured into the chamber defined by the respective floors of the inner and outer bowls without first removing the inner bowl. Such an arrangement simplifies the preparation of the meal by the consumer and provides other advantages as discussed below.

The conduit means may comprise an opening defined by a portion of the rim of the outer bowl and/or a portion of the rim of the inner bowl. For example, the rim and the adjacent portion of the side wall of the inner bowl may be recessed inwardly such that, together with the rim and adjacent side wall of the outer bowl, there is formed a channel leading to the interior of the lower food chamber.

The invention will now be illustrated in greater detail by reference to the accompanying drawings of which Figure 1 is a plan view of one embodiment showing the inner container resting inside the outer container, Figure 2 is a sectional side view showing the inner container resting inside the outer container, and Figure 3 is a plan view of a container system according to a second embodiment of the invention.

As illustrated in Figures 1 and 2, the outer container is a thin-walled bowl 1 formed from filled polypropylene by a thermo-forming moulding process in conventional fashion. The bowl is circular in plan and is provided with a rim 2. The rim 2 has two widened portions 3 and 4 which are diametrically opposed and function as handles. The inner edge of the widened portion of the rim has recesses 5 and 6 for engaging complementary widened rim portions 10 and 11 on the inner bowl 9. The undersides of the widened portions 3 and 4 are provided for strengthening purposes with arcuate ribs which appear from above as arcuate grooves 7 and 8.

The inner container is also provided with a peripheral rim 12, two widened portions 10 and 11 of which function both as handles and as a means of supporting the inner bowl in the outer bowl. The widened portions 10 and 11 are configured such that they rest in, and are a close fit with, the recesses 5 and 6 in the rim of the outer container. The shallower inner bowl is thus supported in the outer bowl such that its floor is spaced above the floor of the outer bowl to define a chamber therebetween in which a pre-cooked dehydrated substance such as rice or pasta is located.

The inner bowl has a laminar structure consisting of inner 12 and outer 13 layers of polypropylene sandwiched between which is a barrier layer 14 formed of ethylene vinyl alcohol polymer. The inner bowl contains a retorted food (not shown) and is sealed at its upper end by means of a peelable barrier membrane (not shown). The outer bowl is provided with a peelable plastics lid (not shown).

During manufacture, the food to be retorted is placed into the inner bowl 9 which is then hermetically sealed with the foil membrane. The seal is created in known fashion by a combination of heat and pressure applied by a profiled sealing head. The seal is made sufficiently strong to withstand the manufacturing conditions to which it is subsequently exposed, and to ensure that its integrity is maintained throughout any subsequent storage period, but is made such that it is "peelable", ie. it is made sufficiently weak that the consumer can peel the lid away from the container. Following sealing, the container is subjected to retorting ie. the application of heat in the form of steam or hot water, under pressure, in known fashion. The retorting process serves both to cook and to sterilise the food.

In a separate operation, a foodstuff such as rice, pasta, potato etc. is cooked and is then dehydrated in accordance with known procedures. An appropriate amount of the resulting cooked dehydrated food is then placed into the outer bowl 1 and the sealed inner bowl 9 containing the cooked sterilised food is placed into the outer bowl 1 so that the widened rim portions 10 and 11 of the inner bowl engage and are supported in the recesses 5 and 6 of the outer bowl. A peelable plastics lid is then fitted to the outer bowl to complete the process.

In use by the consumer, the lid is removed and the inner bowl 9 is separated from the outer bowl 1. The foil membrane is removed from the inner bowl. A predetermined quantity of water is added to the contents of the outer bowl, the quantity of water conveniently being predetermined by means of a marker line formed in the wall of the outer container, and both bowls are then subjected to heating in a microwave oven. When an appropriate heating period has elapsed, such that the contents of the inner bowl 9 are adequately heated and the dehydrated matter in the outer bowl has rehydrated fully, the contents of the inner bowl can be poured into the outer bowl to provide a ready-to-eat cooked meal. Alternatively, both bowls may advantageously be removed from the microwave oven before the contents of the outer bowl have fully hydrated (eg. after three and a half minutes) and then left to stand for approximately one minute. During this period, the food in the inner bowl cools to a

more comfortable temperature for eating, whilst the contents of the outer bowl continue to re-hydrate until full re-hydration is achieved.

It will be appreciated that by using the packaging system as defined herein, the consumer is presented with a meal which has an authentic layered appearance, ie. the carbohydrate and meat/vegetable sauce components of the meal are in discrete layers.

Figure 3 illustrates a set of nested containers generally similar to the containers illustrated in Figures 1 and 2 except that certain modifications have been made to the inner container. Thus the outer container, as before, is a thin-walled bowl 17 formed from filled polypropylene. The bowl 17 is generally circular or elliptical in plan and is provided with a rim 18 which has two diametrically opposed widened portions 19 and 20. The inner edge of the widened portions of the rim have recesses 21 and 22 for engaging complementary widened rim portions 23 and 24 on the inner bowl 25. In Figure 3, recess 21 and complementary rim portion 23 are shown as being narrower than recess 22 and rim portion 24 respectively, although this need not necessarily be the case.

As with the embodiment illustrated in Figures 1 and 2, the inner container 25 is provided with a peripheral rim 26, two widened portions 23 and 24 of which function both as handles and as a means of supporting the inner bowl 25 in the outer bowl 17.

The shallower inner bowl 25 is thus supported in outer bowl 17 such that its floor is spaced above the floor of the outer bowl 17 to define a chamber therebetween for the purposes described above. The bowls are sealed with protective foil membranes and/or plastic lids (not shown) in a manner similar to that described above in respect of Figures 1 and 2.

The inner bowl 25 has a similar laminar structure to, and is constructed of the same materials as, the inner bowl 9 illustrated in Figures 1 and 2. However, it differs from inner bowl 9 with regard to its shape, in that its side wall and rim have a recessed portion 27 which gives the inner bowl a kidney shape in plan. Thanks to the recessed portion 27, there is provided a gap bounded by inner bowl rim portion 28 and outer bowl rim portion 18a which constitutes an opening 29 into the chamber between the floors of the two bowls. The provision of the opening 29 is particularly advantageous as will now be described.

As is described above, the consumer using the food product illustrated in Figures 1 and 2 must separate outer and inner bowls in order to add water to the dehydrated matter in the outer bowl. However, by providing the opening 29 in the product illustrated in Figure 3, the requisite amount of

water can be added to the contents of the outer bowl without separating the two bowls. A further advantage is that the food product can subsequently be subjected to microwave heating without the two bowls being separated. A benefit which follows from this is that a "steaming chamber" is created between inner and outer bowls which has the effect of rehydrating the dehydrated foodstuff much more quickly. For example, it has been found that when using the arrangement shown in Figures 1 and 2, a particular carbohydrate such as rice or pasta requires microwaving for three and a half minutes followed by one minute for "rest" during which time the rehydration process is completed. Using the same carbohydrate in the nested bowl arrangement of Figure 3, the carbohydrate is fully hydrated after three minutes of heating in the microwave oven and requires no "resting" time following microwaving.

A further benefit is that the contents of the inner bowl are heated both by the microwave radiation and by heat transfer from boiling water in the outer bowl beneath it. This means that the contents of the inner bowl are heated more uniformly, and a problem often encountered in microwave cooking, ie the formation of cold spots, is thereby avoided.

A still further benefit of the nested bowl arrangement of Figure 3 is that the opening 29 provides a means for straining excess water without losing rehydrated foodstuff from the outer bowl.

### Claims

1. A food product comprising first and second nested containers, the first, inner, container (9) being a closed container capable of withstanding retorting conditions and containing a food which has been subjected to cooking by retorting in the first container (9); the second, outer, container (1) being a closed container formed of a non-metallic (e.g. plastics) material capable of withstanding temperatures generated in a microwave oven, the said second container containing a dehydrated foodstuff, characterised in that the first container (9) is formed of a non-metallic (e.g. plastics) material, the said first container (9) being in the form of a dish.
2. A food product according to claim 1 wherein the first and second containers (9, 1) are a pair of nested bowls.
3. A food product according to claim 2 wherein the first of the two nested bowls (9) rests inside the second bowl (1) such that the floor of the inner bowl (1) is spaced above the floor of the outer bowl (1) to define a chamber therebetween in which is located the dehydrated foodstuff.
4. A food product according to any of the preceding claims wherein the dehydrated foodstuff is selected from instant rice, instant pasta, instant potato, instant pulses and instant fruit and vegetables.
5. A food product according to any of the preceding claims wherein the inner bowl (9) is provided with a rim (12), widened portions (10, 11) of which rest on recesses (5, 6) in the rim (2) of the outer bowls (1) thereby to support the inner bowl (9) such that the floor of the inner bowl (9) is spaced above the floor of the outer bowl (1) to define a chamber therebetween.
6. A food product as claimed in any preceding claim in which the first container (9) is sealed by means of a removable membrane (15) or lid, the first container (9) resting inside the second container (1) such that the floor of the first container (9) is spaced above the floor of the second container (1) to define a chamber therebetween in which is contained a hydratable predominantly carbohydrate-based food, both first and second containers (9, 1) being resistant to conditions generated inside a microwave oven.
7. A food product as claimed in any preceding claim comprising a closed container consisting essentially of an outer container (1) formed of a food grade plastics material, and an inner sealed container (9) removably supported inside the outer container (1) such that its floor is spaced above the floor of the outer chamber (1) to define a first food-containing chamber therebetween, the inner sealed container (9) being formed of a material or materials capable of withstanding retorting and microwave heating conditions and being closed by a removable sealing member (15), the sealed container being impermeable to gas and moisture and defining a second food-containing chamber, wherein the first chamber contains a pre-cooked dehydrated food and the second chamber contains a retorted food, and the ratio of the volume of the first chamber to the second chamber is in the range from 2:1 to 1:2, for example 1:1.5 to 1.5:1, preferably 1.5:1 to 1:1.
8. A food product according to any one of claims 3 to 7 comprising conduit means (29) to permit liquid to be poured into the chamber defined by the respective floors of the inner (9) and

outer bowls (1) without first removing the inner bowl (9).

9. A food product according to claim 8 wherein the conduit means (29) comprises an opening defined by a rim portion (18a) of the outer bowl and/or a rim portion of the inner bowl (28).
10. A food product according to claim 9 wherein the rim and a side wall of the inner bowl are recessed inwardly such that, together with the rim and a portion of a side wall of the outer bowl, they define a channel (29) constituting the conduit means (29).
11. A food product as defined in any one of the preceding claims wherein the food contained within the first or inner container has a viscosity in the range 100 - 10,000 centipoise (preferably greater than 1750 centipoise, e.g. up to 5000 centipoise), at 20 °C as measured by a Brookfield viscometer (RVT) fitted with a spindle member number 4 at a speed of 20 r.p.m.
12. A food product as defined in any one of the preceding claims wherein the food contained within the first, inner, container (9) has a water content equivalent to less than one hundred percent of the water absorption capacity of the dehydrated foodstuff in the second, outer, container (1).
13. A food product as defined in any one of the preceding claims wherein the first, inner, container (9) is formed of a multilayer plastics material comprising a gas- and moisture-impermeable barrier (14) membrane sandwiched between inner and outer layers (12, 13).

#### Patentansprüche

1. Ein Nahrungsmittelprodukt, umfassend erste und zweite ineinandergefügte Behälter, von denen der erste, innere, Behälter (9) ein geschlossener Behälter ist, der in der Lage ist, Erhitzungsbedingungen auszuhalten und ein Nahrungsmittel zu enthalten, das dem Kochen durch Erhitzen in dem ersten Behälter (9) unterworfen worden ist; der zweite, äußere, Behälter (1) ein geschlossener Behälter ist, der aus einem nicht-metallischen (zum Beispiel Kunststoff) Material ausgeformt ist und in der Lage ist, Temperaturen auszuhalten, die in einem Mikrowellenofen erzeugt werden, wobei dieser zweite Behälter ein dehydratisiertes Lebensmittel enthält, dadurch gekennzeichnet, daß der erste Behälter (9) aus einem nicht-

metallischen (zum Beispiel Kunststoff) Material ausgeformt ist, wobei der erste Behälter (9) in der Form einer Schale ausgeformt ist.

2. Ein Nahrungsmittelprodukt nach Anspruch 1, bei dem der erste und der zweite Behälter (9,1) ein Paar ineinandergefügte Schüsseln sind.
3. Ein Nahrungsmittelprodukt nach Anspruch 2, bei dem die erste der zwei ineinandergefügten Schüsseln (9) innerhalb der zweiten Schüssel (1) derart liegt, daß der Boden der inneren Schüssel (9) über dem Boden der äußeren Schüssel (1) mit Abstand liegt, um eine Kammer zwischen ihnen zu bilden, in der das dehydratisierte Nahrungsmittel angeordnet ist.
4. Ein Nahrungsmittelprodukt nach einem der vorhergehenden Ansprüche, bei dem das dehydratisierte Lebensmittel aus Instant-Reis, Instant-Nudeln, Instant-Kartoffeln, Instant-Hülsenfrüchten und Instant-Früchten und -Gemüsen ausgewählt ist.
5. Ein Nahrungsmittelprodukt nach einem der vorhergehenden Ansprüche, bei dem die innere Schüssel (9) mit einem Rand (12) versehen ist, von dem verbreiterte Abschnitte (10,11) auf Aussparungen (5,6) in dem Rand (2) der äußeren Schüssel (1) ruhen, um dadurch die innere Schüssel (9) derart zu halten, daß der Boden der inneren Schüssel (9) über dem Boden der äußeren Schüssel (1) beabstandet ist, um dazwischen eine Kammer auszubilden.
6. Ein Nahrungsmittelprodukt nach einem der vorhergehenden Ansprüche, bei dem der erste Behälter (9) mittels einer entfernbaren Membran (15) oder eines Deckelsabgedichtet ist, wobei der erste Behälter (9) innerhalb des zweiten Behälters (1) derart ruht, daß der Boden des ersten Behälters (9) über dem Boden des zweiten Behälters (1) so beabstandet ist, daß eine Kammer dazwischen gebildet wird, in der ein mit Wasser auflösbares Nahrungsmittel vorwiegend auf Kohlehydratbasis enthalten ist, wobei sowohl der erste als auch der zweite Behälter (9,1) beständig gegen Bedingungen sind, die innerhalb eines Mikrowellenofens erzeugt werden.
7. Ein Nahrungsmittelprodukt nach einem der vorhergehenden Ansprüche, das einen geschlossenen Behälter umfaßt, der im wesentlichen aus einem äußeren Behälter (1), der aus einem Kunststoffmaterial mit Lebensmittelqualität ausgeformt ist, und einem inneren abge-

- dichteten Behälter (9), der entfernbar innerhalb des äußeren Behälters (1) derart gehaltert ist, daß sein Boden über dem Boden der äußeren Kammer (1) gelegen ist, um eine erste Lebensmittel enthaltende Kammer dazwischen zu bilden, besteht, wobei der innere abgedichtete Behälter (9) aus einem Material oder aus Materialien ausgeformt ist, die in der Lage sind, Kochen und Mikrowellenheizbedingungen auszuhalten, und durch ein entfernbares Dichtungsglied (15) verschlossen ist, der abgedichtete Behälter für Gas und Feuchtigkeit undurchlässig ist und eine zweite Lebensmittel enthaltende Kammer bildet, wobei die erste Kammer ein vorgekochtes dehydriertes Nahrungsmittel enthält und die zweite Kammer ein gekochtes Lebensmittel enthält, und das Verhältnis des Volumens der ersten Kammer zu dem der zweiten Kammer in dem Bereich von 2:1 bis 1:2, zum Beispiel 1:1,5 bis 1,5:1, vorzugsweise 1,5:1 bis 1:1, liegt.
8. Ein Nahrungsmittelprodukt nach einem der Ansprüche 3 bis 7, das eine Leitungseinrichtung (29) umfaßt, um zu gestatten, daß Flüssigkeit in die Kammer gegossen wird, die durch die entsprechenden Böden der inneren (9) und der äußeren Schüsseln (1) gebildet wird, ohne zuerst die innere Schüssel (9) zu entfernen.
9. Ein Nahrungsmittelprodukt nach Anspruch 8, bei dem die Leitungseinrichtung (29) eine Öffnung umfaßt, die von einem Randabschnitt (18a) der äußeren Schüssel und/oder einem Randabschnitt der inneren Schüssel (28) gebildet wird.
10. Ein Nahrungsmittelprodukt nach Anspruch 9, bei dem der Rand und eine Seitenwand der inneren Schüssel nach innen derart ausgenommen sind, daß sie zusammen mit dem Rand und einem Abschnitt einer Seitenwand der äußeren Schüssel einen Kanal (29) begrenzen, der die Leitungseinrichtung (29) bildet.
11. Ein Nahrungsmittelprodukt nach einem der vorhergehenden Ansprüche, bei dem das innerhalb des ersten oder inneren Behälters enthaltene Nahrungsmittel eine Viskosität in dem Bereich von 100 bis 10000 Centipoise (vorzugsweise größer als 1750 Centipoise, zum Beispiel bis zu 5000 Centipoise) bei 20 °C, gemessen durch ein Brookfield-Viskosimeter (RVT), das mit einem Spindelglied Nr. 4 bei einer Geschwindigkeit von 20 Upm ausgestattet ist, hat.
12. Ein Nahrungsmittelprodukt nach einem der vorhergehenden Ansprüche, bei dem das innerhalb des ersten, inneren, Behälters (9) enthaltene Nahrungsmittel einen Wassergehalt hat, der equivalent zu weniger als 100% der Wasserabsorptionskapazität des dehydrierten Nahrungsmittels in dem zweiten, äußeren Behälter (1) ist.
13. Ein Nahrungsmittelprodukt nach einem der vorhergehenden Ansprüche, bei dem der erste, innere Behälter (9) aus einem mehrschichtigen Kunststoffmaterial ausgeformt ist, das eine gas- und feuchtigkeitsundurchlässige Sperrmembran (14) umfaßt, die sandwich-artig zwischen der inneren und der äußeren Schicht (12,13) liegt.

### Revendications

- Produit pour aliments comportant un premier et un second conteneurs emboîtés, le premier conteneur (9) intérieur étant un conteneur fermé capable de résister à des conditions de cuisson en cornue et contenant un aliment qui a été soumis à une cuisson en cornue dans le premier conteneur (9), le second conteneur (1) extérieur étant un conteneur fermé formé d'un matériau non métallique, par exemple une matière plastique, capable de résister aux températures engendrées dans un four à micro-ondes, ledit second conteneur contenant un produit alimentaire déshydraté, caractérisé en ce que le premier conteneur (9) est formé de matériau non métallique, par exemple une matière plastique, ledit premier conteneur (9) ayant la forme d'un plat.
- Produit pour aliments selon la revendication 1 dans lequel le premier et le second conteneurs (9, 1) sont deux bols emboîtés.
- Produit pour aliments selon la revendication 2, dans lequel le premier (9) des deux bols emboîtés et en appui à l'intérieur du second bol (9) de telle sorte que le fond du bol intérieur (1) est espacé au-dessus du fond du bol extérieur (1) pour définir entre eux une chambre dans laquelle est située le produit alimentaire déshydraté.
- Produit pour aliments selon l'une quelconque des revendications précédentes, dans lequel le produit alimentaire déshydraté est choisi parmi le riz instantané, les pâtes instantanées, les pommes de terre instantanées, les légumineuses instantanées et les fruits instantanés et les légumes.

5. Produit pour aliments selon l'une quelconque des revendications précédentes, dans lequel le bol intérieur (9) est muni d'un bord (12), des parties élargies (10, 11) de celui-ci étant en appui sur des creux (5, 6) situés dans le rebord (2) du bol extérieur (1) pour supporter ainsi le bol intérieur (9) de telle sorte que le fond du bol (9) intérieur soit espacé au-dessus du fond du bol extérieur (1) pour définir entre eux une chambre.
6. Produit pour aliments selon l'une quelconque des revendications précédentes dans lequel le premier conteneur (9) est rendu étanche par l'intermédiaire d'une membrane ou couvercle (15) amovible, le premier conteneur (9) étant en appui à l'intérieur du second conteneur (1) de telle sorte que le fond du premier conteneur (9) soit espacé au-dessus du fond du second conteneur (1) pour définir entre eux une chambre dans laquelle est contenue un produit pouvant être hydraté ayant pour base prédominante des carbohydrates, à la fois le premier et le second conteneurs (9, 1) résistant aux conditions engendrées à l'intérieur d'un four à micro-ondes.
7. Produit pour aliments selon l'une quelconque des revendications précédentes, comportant un conteneur fermé constitué essentiellement d'un conteneur extérieur (1) en matière plastique de qualité alimentaire, et d'un conteneur intérieur rendu étanche (9) supporté de manière amovible à l'intérieur du conteneur extérieur (1) de telle sorte que son fond soit écarté au-dessus du fond du conteneur extérieur (1) pour définir entre eux une première chambre contenant un aliment, le conteneur intérieur rendu étanche (9) étant formé d'une matière ou de plusieurs matières capables de résister à une cuisson en cornue et au chauffage par micro-ondes et étant fermé par un élément d'étanchéité amovible (15), le conteneur rendu étanche étant imperméable aux gaz et à l'humidité et définissant une seconde chambre contenant un aliment, dans lequel la première chambre contient un aliment déshydraté précuit et la seconde chambre contient un aliment cuit en cornue, et le rapport du volume de la première chambre sur celui de la seconde chambre est situé dans la plage allant de 2/1 à 1/2, par exemple de 1/1,5 à 1,5/1, de préférence 1,5/1 à 1/1.
8. Produit pour aliments selon l'une quelconque des revendications 3 à 7, comportant des moyens (29) formant conduit pour permettre de déverser un liquide à l'intérieur de la chambre définie par les fonds respectifs du bol intérieur (9) et du bol extérieur (1) sans tout d'abord enlever le bol intérieur (9).
9. Produit pour aliments selon la revendication 8, dans lequel les moyens (29) formant conduit comportent une ouverture définie par une partie (18a) formant rebord du bol extérieur et/ou une partie formant rebord du bol intérieur (28).
10. Produit pour aliments selon la revendication 9, dans lequel le rebord et une paroi latérale du bol intérieur sont en creux en direction de l'intérieur de telle sorte que lorsqu'ils sont associés au rebord et à une partie de paroi latérale du bol extérieur, ils définissent un canal (29) constituant les moyens (29) formant conduit.
11. Produit pour aliments selon l'une quelconque des revendications précédentes dans lequel l'aliment contenu à l'intérieur du premier conteneur ou conteneur intérieur a une viscosité située dans la plage allant de 100 à 10000 centipoises, de préférence plus grande que 1750 centipoises, allant par exemple jusqu'à 5000 centipoises, à 20 °C, telle que mesurée par un viscosimètre Brookfield (RVT) muni d'un élément formant tornillon portant le numéro 4, à une vitesse de 20 tours par minute.
12. Produit pour aliments selon l'une quelconque des revendications précédentes, dans lequel l'aliment contenu à l'intérieur du premier conteneur (9) intérieur, a une teneur en eau équivalente à moins de 100% de la capacité d'absorption d'eau du produit alimentaire déshydraté du second conteneur (1) extérieur.
13. Produit pour aliments selon l'une quelconque des revendications précédentes, dans lequel le premier conteneur (9) intérieur est formé de plusieurs couches de matières plastiques comportant une membrane formant barrière (14) imperméable aux gaz et à l'humidité enserrée entre des couches intérieure et extérieure (12, 13).

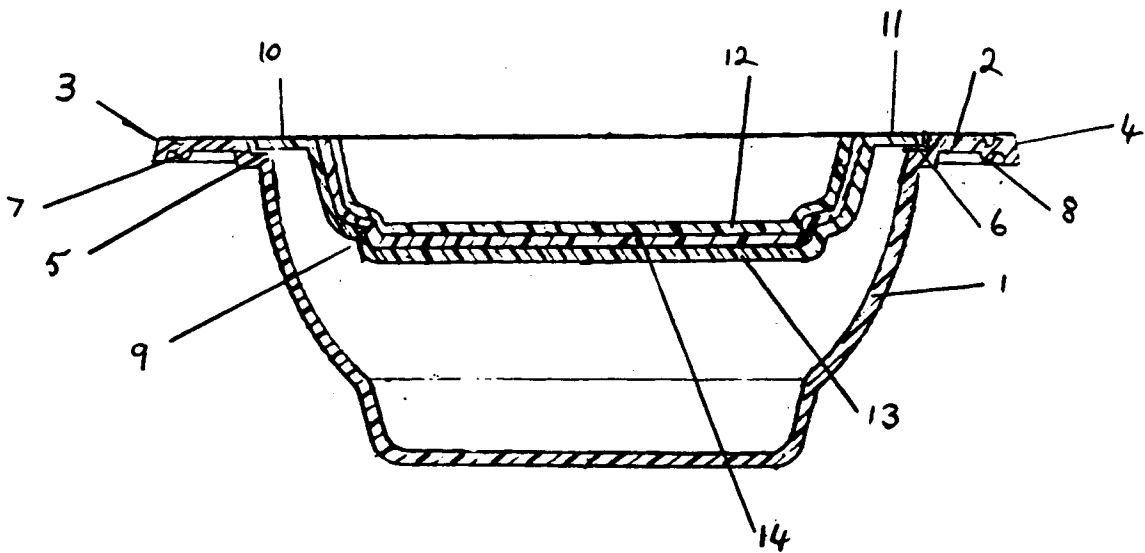
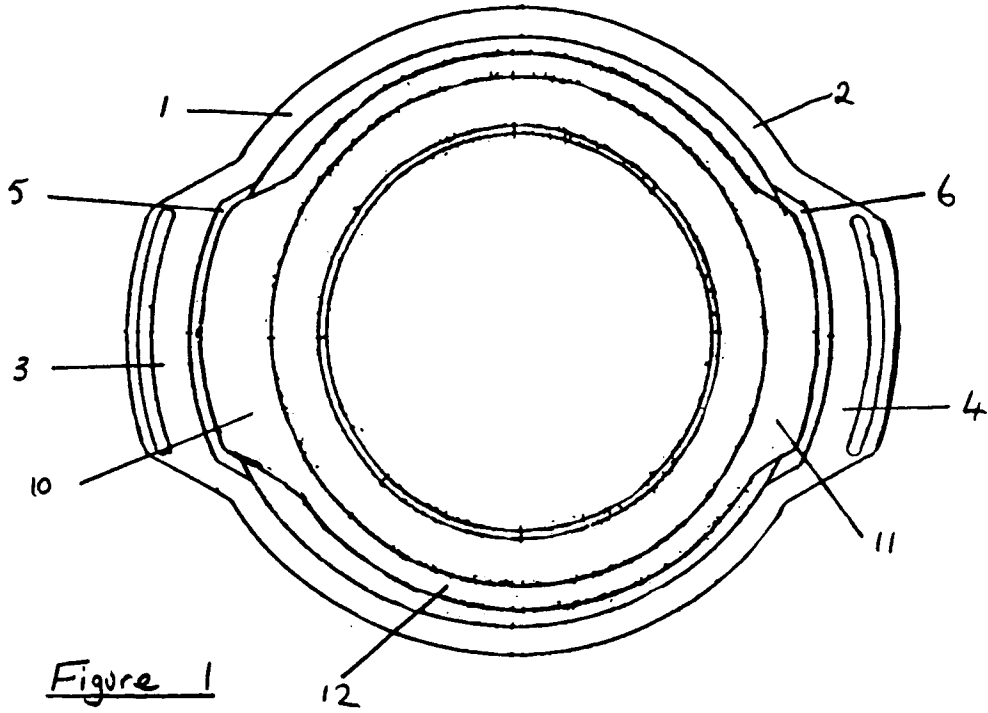

Figure 2

Figure 3

