

(No Model.)

3 Sheets—Sheet 1.

C. P. HIGGINS.
RIVETING MACHINE.

No. 524,325.

Patented Aug. 14, 1894.

Fig. 1.

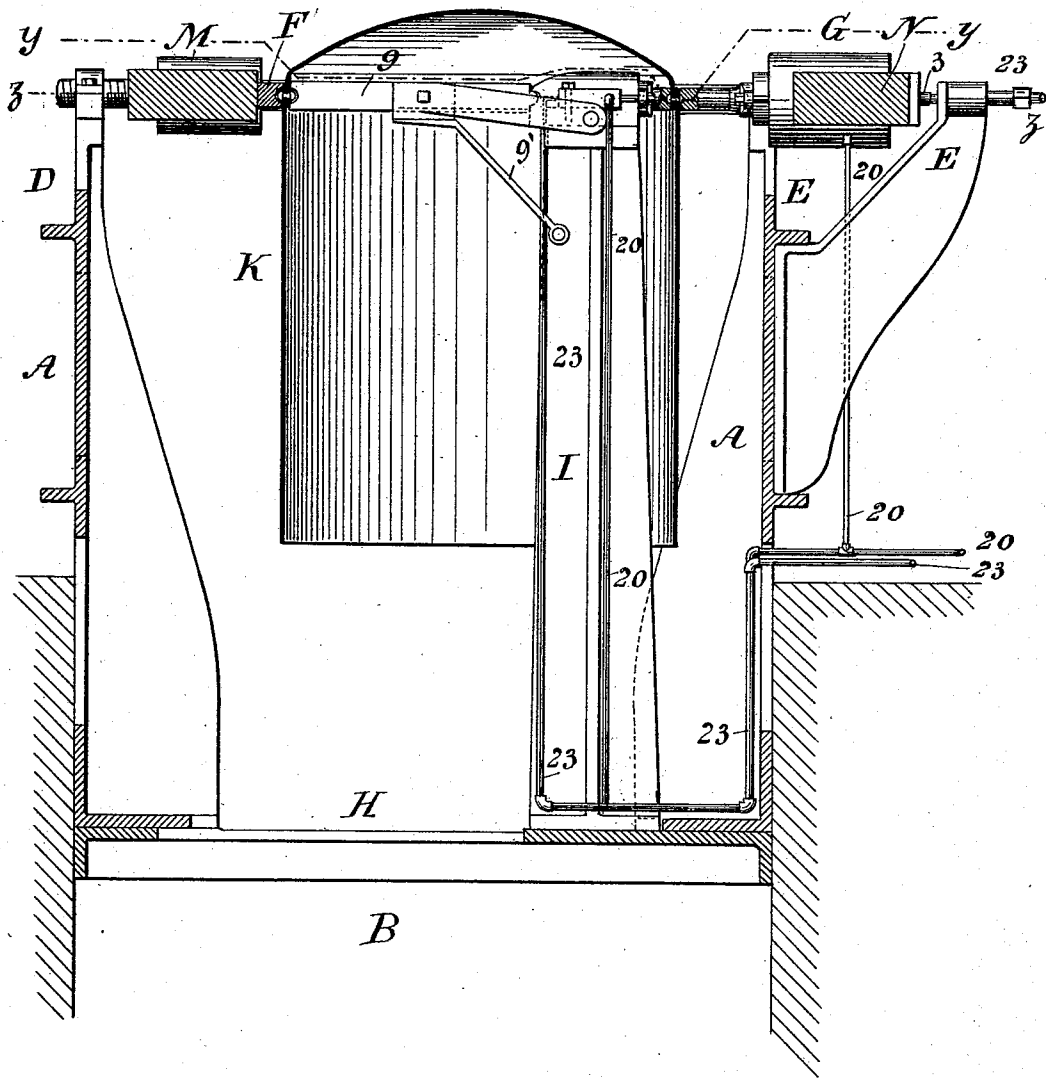

Witnesses
Chas. Hanimann
E. MacArthur

Inventor
Campbell P. Higgins
By his Attorney
Chas. W. Jordan

(No Model.)

3 Sheets—Sheet 2.

C. P. HIGGINS.
RIVETING MACHINE.

No. 524,325.

Patented Aug. 14, 1894.

Fig. 2.

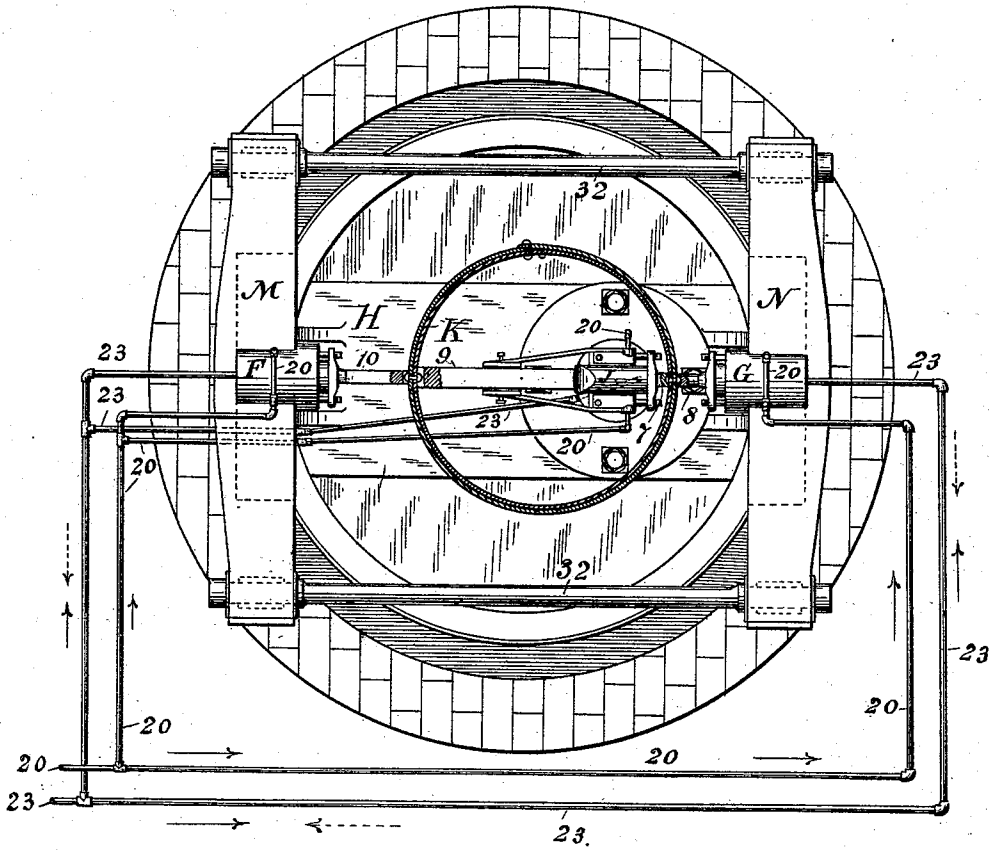

Witnesses
Chas. Hanemann
E. Wae Entie

Inventor
Campbell P. Higgins
By his Attorney
Chas. W. Foster

(No Model.)

3 Sheets—Sheet 3.

C. P. HIGGINS. RIVETING MACHINE.

No. 524,325.

Patented Aug. 14, 1894.

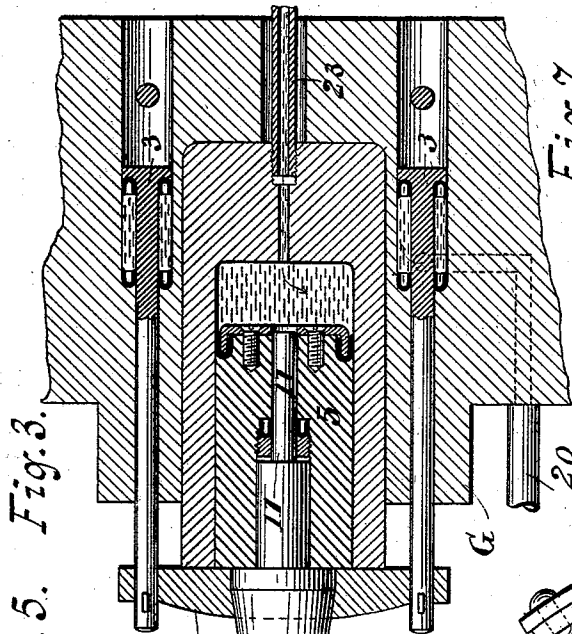

Fig. 3.

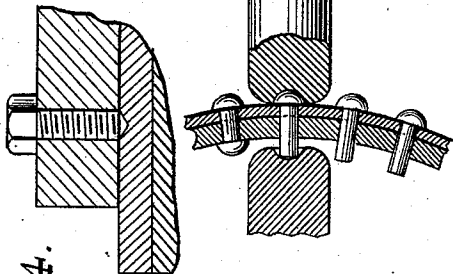

Fig. 4.

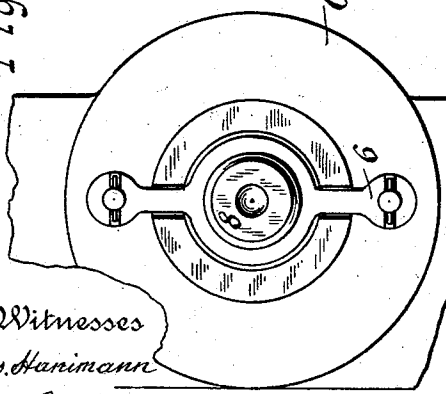

Fig. 5.

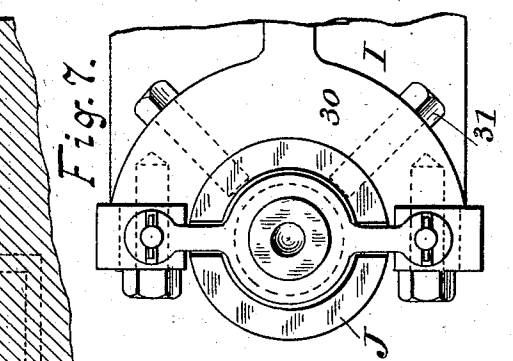

Fig. 6.

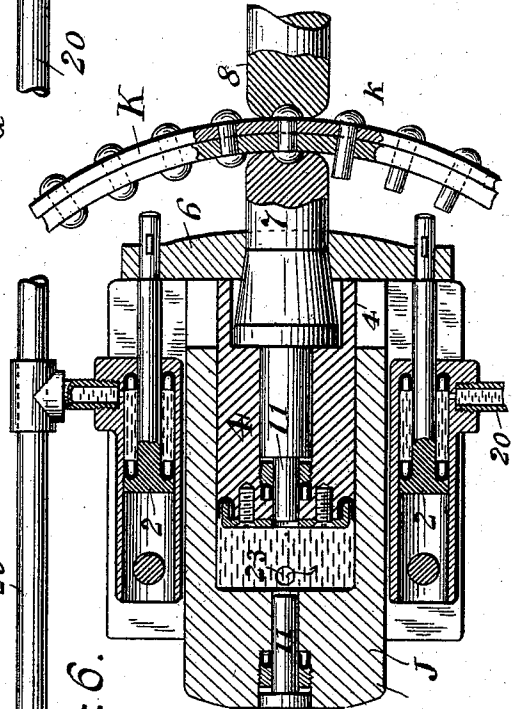

Fig. 7.

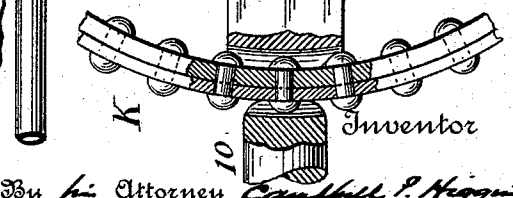

Fig. 8.

Witnesses
Chas. Hanemann
& Mac Cutler

Inventor
Campbell P. Higgins
 By his Attorney
Chas. W. Forster

UNITED STATES PATENT OFFICE.

CAMPBELL P. HIGGINS, OF ROSELLE, NEW JERSEY.

RIVETING-MACHINE.

SPECIFICATION forming part of Letters Patent No. 524,325, dated August 14, 1894.

Application filed May 27, 1893. Serial No. 475,787. (No model.)

To all whom it may concern:

Be it known that I, CAMPBELL P. HIGGINS, a citizen of the United States, residing at Roselle, in the county of Union and State of New Jersey, have invented certain new and useful Improvements in Hydraulic Riveting-Machines, of which the following is a specification.

The invention is applicable for riveting drums or other structures within which a long reach is required to perform the work.

The object of the invention is to provide an apparatus wherein the reach may be practically unlimited in range and the required compression effected without strain on the interior support.

The invention consists in an apparatus having a series of hydraulic plungers aligned so as to form when extended, a continuous abutting connection from one exterior support to and through the work to another exterior support; the interior support is thereby relieved of the function of resisting the working strains, and may therefore be projected from its fastening point to any desired distance to suit the longest drum.

The invention also embodies certain various novel details of construction; and in order to enable others skilled in the art to which said invention appertains to understand and use the same, I will proceed to describe its construction, explain its operation, and point out in the appended claims its novel characteristics.

Referring to the accompanying drawings: Figure 1, is a sectional elevation of an apparatus embodying my invention; Fig. 2, a plan view of Fig. 1, partly taken in section on the line *y y*; Fig. 3, a horizontal section showing the construction of each of the exterior rams on an enlarged scale; Fig. 4, an end view of Fig. 3; Fig. 5, a detail sectional view pertaining to Fig. 3; Fig. 6, a horizontal sectional view showing the hydraulic ram interior to the work in detail; and Fig. 7, an end view of Fig. 6.

A, Fig. 1, represents the external structure or framework of the apparatus, comprising a shell which is placed within a foundation of masonry B, extending for convenience below the level of the floor C.

Upon the shell or main frame A, are mounted the standards D, E, carrying the ex-

ternal hydraulic cylinders F, G, secured at fixed distances apart by means of cross beams, M, N, and tie rods 32, Fig. 2.

In the base of the shell A, a bed-plate H, is provided, upon which the interior idle support I, is mounted, supporting the internal hydraulic cylinder J. The standard I, may be of any suitable length, and the shell A, of any suitable depth and diameter such as necessary or convenient for the reception of the work K, having the intended dimensions.

Pipes 20, 23, for operating the plunger of the internal hydraulic cylinder J, are arranged to pass down into the shell A, and upward along the sides of the column I, giving clearance to the work as seen in Fig. 1.

Referring to Figs. 1, and 2, and also to Figs. 3 and 6, the pipes indicated by 20, supplied with a constant minimum pressure, extend to the various parts of the apparatus to operate the retracting plungers 2, 2, and 3, 3, which counteract the working plungers 4, 5, to release them from the work after each operation.

The pipes 23, extend from a source of variable maximum pressure to the several working plungers 4, 5.

The pipes 20, may be connected to the constant pressure pipes of an apparatus for automatically intensifying and equalizing pressure such as described in my separate patent application filed simultaneously herewith, Serial No. 475,788, and the pressure pipes 23, may be connected to the delivery pipe of the compressor described therein and controlled by means of a suitable distributing valve adapted to alternately charge and exhaust such pipes 23, at each operation.

Referring to the detail views, Figs. 3, to 7, inclusive, the several plungers 2, 3, 4, 5, are provided with suitable hydraulic packings. The working plungers 4, and 5, are each provided with cross-heads 6, to which the retracting plungers 2, 2, 3, 3, are connected.

The riveting rams, 7, 8, and 9, 10, are removable and interchangeable for others of different lengths; such being selected as will complete when in working position a continuous abutting connection from the one exterior support D, to and through the work K, to the other exterior support E; the diameter of the drum K, or dimension of other work determining the selection.

In event of error in the selection of any of

the plungers 7, 8, 9, 10, means are provided for permitting the escape of the working pressure from cylinders F, G, or J. This consists in packed lugs 11, provided to each ram, which project through each cylinder or its working plunger, and are exposed to the pressure within. In event of any of the rams being too short and failing to make abutting connection preparatory to the operation of the machine, such ram is forced out until its plug 11, allows an escape opening for the working pressure to find its exit, thus avoiding lateral strain upon the column I, or other cause of injury to the apparatus.

As seen in Fig. 7, the cylinder J, is secured in a hollow block 30, by means of bolts 31.

The cylinders F, G, are made integral with or supported in yokes M, N, connected together by tie rods 32, at a sufficient distance apart to clear the work. Thus, the standards D, E, are free from strain, and as is the case with the column I, serve solely to support the hydraulic cylinders at coincident level.

In operation, all the rams 7, 8, and 9, 10, may be used for riveting simultaneously; the rivets *k*, on both sides of the drum being upset at each compression, as seen in Fig. 6, and the drum rotated at each retractive movement of the plungers 4, 5, doubling the capacity of the apparatus as compared with machines heretofore used.

This invention may also be applied for the

purpose of punching plates, or punching the rivet holes after the drums have been formed.

Having thus fully described my invention, what I claim, and desire to secure by Letters Patent, is—

1. In a hydraulic riveting machine, the combination of a series of external and internal hydraulic cylinders and rams connected therewith in axial line when in working position, to operate simultaneously on both sides of the work and form a continuous abutting connection from one fixed support to and through the work to another fixed support.

2. The combination, in a hydraulic riveting machine, of two external fixed supports, an internal support, a terminal hydraulic cylinder and ram on each external support, also an intermediate hydraulic cylinder and ram on the internal support, said riveting rams operating and abutting in continuous series from one said support to the other.

3. A riveting machine composed of external supports and an internal support, with hydraulic cylinders and riveting rams arranged in axial line on the respective supports, the internal support being projected to any desired distance within the work.

CAMPBELL P. HIGGINS.

Witnesses:

L. D. BURNHAM,
W. A. PEARSALL.