

March 7, 1944.

C. A. FOX

2,343,657

DRYING RACK

Filed Dec. 10, 1944.

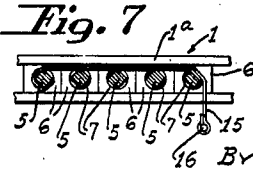
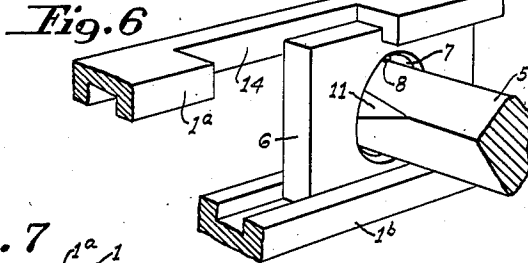
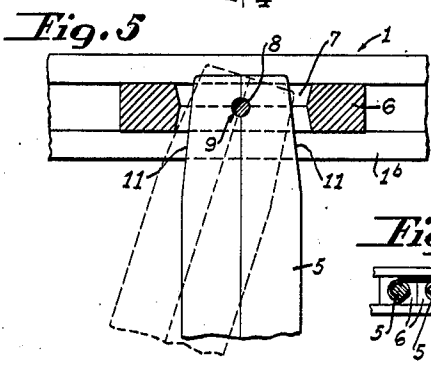
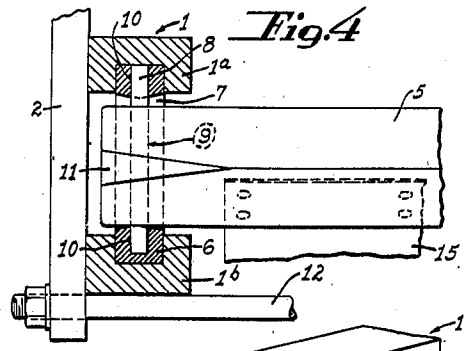
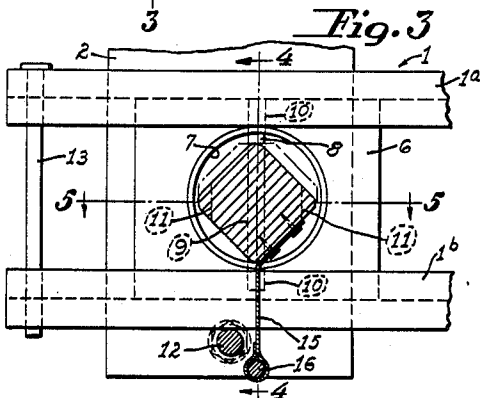
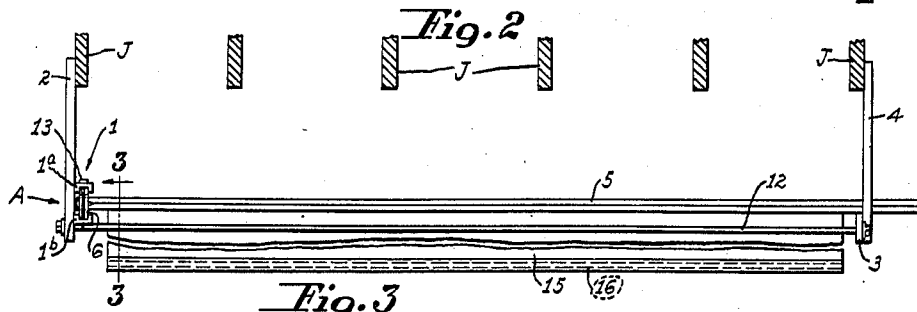
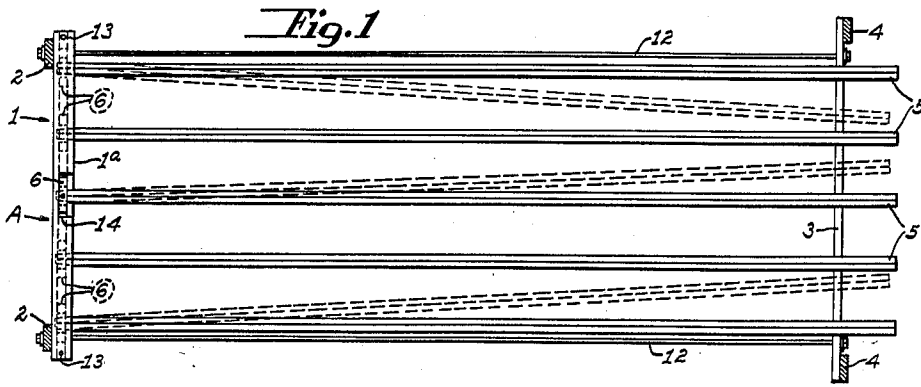

INVENTOR
CHARLES ADIN FOX
BY *Em Harrington*
ATTORNEY

UNITED STATES PATENT OFFICE

2,343,657

DRYING RACK

Charles Adin Fox, Oakland Village, Mo.

Application December 10, 1942, Serial No. 468,463

5 Claims. (Cl. 211-46)

This invention relates generally to drying racks and more specifically to drying racks for laundered articles, the predominant object of the invention being to provide a rack of this description which is particularly well adapted for use in basements and other locations in homes, flats, and apartments where space is limited and where the maximum hanging space for laundered articles is desired.

As is quite well known to the average individual, it has been the usual practice heretofore for persons living in homes, flats, and apartments, who desired to dry laundered articles indoors, to string clothes lines ordinarily in the basements of the structures in which they lived, for supporting the laundered articles while same were drying. Such strung clothes lines usually were quite a nuisance inasmuch as they were in the way if permitted to remain up in their strung condition permanently so that they interfered with movement of persons and articles about the basement, and if they were put up for each drying operation and were taken down after the drying operation, considerable work was involved. The predominant object of the present invention, therefore, is to provide a drying rack which is so characterized that it may remain permanently in place at all times and when not in use may be caused to assume a non-operative condition where the rack occupies the minimum of space and where said rack is in an out-of-the-way position, for instance adjacent to a wall, where it will not interfere in any manner with movement about the basement.

Briefly stated the improved rack comprises a plurality of elongated bars which are supported for sliding movement with respect to a trackway located at one end of the group of bars, and relative to a supporting member located adjacent to the opposite end of the group of bars. In their proper positions the elongated bars extend at an approximate right angle relative to the trackway by which they are slidingly supported, and an important feature of the invention is the provision of means, forming parts of the rack structure, which prevent a binding action being set up between the elongated bars and the trackway that would, in the absence of such means, interfere with free sliding movement of the bars with respect to the trackway if the bars should be displaced from their proper positions relative to the trackway.

Fig. 1 is a plan view of the improved rack with

the supporting brackets thereof shown in section.

Fig. 2 is a front elevation of the improved rack showing same supported by joists of a building, such joists and associated joists being shown in section.

Fig. 3 is an enlarged fragmentary section taken on line 3-3 of Fig. 2.

Fig. 4 is a fragmentary section taken on line 4-4 of Fig. 3.

Fig. 5 is a fragmentary section taken on line 5-5 of Fig. 3.

Fig. 6 is a fragmentary perspective with portions shown in section and illustrating a bar of the improved rack, together with its associated head, in assembled relation with the trackway of the rack.

Fig. 7 is a cross-section of the improved rack on a reduced scale showing the bars thereof in their non-operative positions and illustrating the protective covering for the bars in its effective position.

In the drawing, wherein is shown for the purpose of illustration, merely one embodiment of the invention, A designates the improved drying rack generally. The rack A includes a trackway 1 which is located at one side of the rack, said trackway comprising a pair of elongated channel members 1a and 1b which are spaced apart in a vertical direction with the channels thereof open toward each other as shown to good advantage in Figs. 4 and 6. The channel members may be made from wood or any other suitable material and they are secured to vertically disposed brackets 2, said brackets being shown in Figs. 1 and 2 as being secured at their upper ends to a joist J of a building although, obviously, they may be secured to other suitable overhead supports. At the opposite end of the rack A an elongated supporting member 3 is provided, and this supporting member is supported in spaced and approximately alined relation with respect to the trackway 1, as shown in Figs. 1 and 2, by brackets 4 which are secured to said supporting member 3 and to a joist J.

Supported by the trackway 1 and the supporting member 3, for sliding movement with respect thereto, is a plurality of elongated bars 5 which may be made from wood or any other suitable material. At the ends of the elongated bars 5 at which the trackway 1 is located, each of said bars is provided with a head 6 which is supported by the trackway for sliding movement longitudinally thereof. The head of each elongated bar

5 comprises a block of wood, or other suitable material, of rectangular shape, whose upper and lower edge portions are disposed for sliding movement in the channels of the channel members 1a and 1b of the trackway 1. Each head 6 has formed therethrough a centrally located opening 7, said opening preferably, though not necessarily, being of circular shape and the wall thereof being shaped so that the opening is of slightly greater diameter at the opposite sides of the head than at the transverse center of said head (see Fig. 5).

Each elongated bar 5 is pivotally attached to its associated head 6, a pivot pin 8 being employed for this purpose. In this connection it is to be noted that an end portion of each elongated bar 5 extends through the opening 7 of its associated head 6 and that the pivot pin 8 is extended loosely through an opening 9 formed through such end portion of the bar with the opposed end portions of the pivot pin seated in similar and aligned openings 10 formed in opposed upper and lower portions of the head 6. Preferably, though not necessarily, the opening 10 in the lower portion of the head 6 is closed at its bottom in order to properly support the pivot pin 8, each elongated bar and its associated head being pivotally assembled by forcing the pivot pin downwardly through the opening 10 in the upper portion of the head, through the opening 9 formed through the bar 5, and into the opening 10 in the lower portion of the head until the lower end of the pivot pin is seated against the bottom wall of said lower opening 10. As is shown to the best advantage in Figs. 3 and 6, the elongated bars 5 are so disposed that the pivot pins 8 thereof extend vertically through the bars from one to the opposite angular edge thereof, and also, at the horizontally opposed angular edges of the bars, said bars are tapered, as indicated at 11, to provide for free pivotal movement about the pivot pins without interference from the walls of the openings 7 of the heads 6.

At the end of the improved rack opposite to the end thereof at which the trackway 1 is located, the elongated bars are supported by the supporting member 3 for sliding movement longitudinally with respect thereto, said bars overhanging said supporting member as shown in Figs. 1 and 2. Also, in order to provide the rack structure with the required stability and rigidity a pair of tie rods 12 are employed, said tie rods extending between and being fixed to the brackets 2 at one side of the rack and the supporting member 3 at the opposite side of the rack.

The heads 6 of the elongated bars 5 are prevented from becoming displaced from the trackway 1 at the opposite ends thereof by pins 13 which are supported in openings formed in the top and bottom solid portions of the channel members 1a and 1b and which extend between said channel members, said pins providing stops which arrest sliding movement of said heads adjacent to the extreme ends of the trackway. Additionally, the upper channel member 1a of the trackway 1 is provided with a cutout portion 14 that is located at the approximate longitudinal center of said channel member. This cutout portion 14 is so shaped and is of such dimensions that an elongated bar 5 may be removed from or assembled with the trackway 1 by passing the head 6 of the bar through said cutout portion. Because of this arrangement it is not necessary to remove several of the elongated bars from the trackway 1 at the forward or rear ends

thereof in order to remove an intermediately positioned bar, as would be the case if the cutout portion 14 were not provided. It is to be noted that the widths of the heads 6 are greater than the heights thereof, and therefore it is not possible for a user to introduce the heads into the trackway 1 in improper positions where the pivot pins 8 would be disposed horizontally, this being so because the greater widths of the heads would not permit the heads to be passed into the channels of the trackway in such improper positions.

When the improved drying rack disclosed herein is not in use the elongated bars 5, together with their associated heads 6, are pushed toward the rear ends of the trackway 1 and the supporting member 3 into closely grouped relation where they occupy relatively little space and where they are located above the heads of persons moving about in the basement or room in which the rack is located. When the bars 5 are arranged in such non-operative positions they are protected from dust by the protective covering 15 shown to the best advantage in Fig. 7. The protective covering comprises a sheet of suitable fabric which is of only slightly less width than the lengths of the bars 5 and is secured at its rear edge to the rearmost bar 5, said sheet of material being provided at its free end with a rod 16. When the bars 5 are in their non-operative positions the protective covering 15 overlies said bars and hangs downwardly from the forward bar to prevent dust from settling on the bars from above. When, however, it is desired to use the rack the protective covering 15 is thrown rearwardly where it hangs downwardly from the rearmost bar 5, as shown in Fig. 3, and the bars are spaced apart as desired to receive the laundered articles, said articles being draped over said bars so that no pins or other fastening devices are required.

An extremely important feature of the invention resides in the fact that the elongated bars 5 are pivotally attached to the heads 6. As a result of this pivotal arrangement, displacement of the bars from their normal rectangularly extended positions relative to the trackway 1 will not cause a binding action to be set up between the heads 6 and the channel members 1a and 1b of the trackway 1 which would interfere with free sliding movement of the heads with respect to the trackway, as would be the case if the bars were rigidly fixed to the heads and they became so displaced.

I claim:

1. A drying rack for laundered articles including a trackway comprising a pair of channel members arranged in vertically spaced relation with the channels thereof facing each other, a plurality of independent heads having opposed upper and lower portions disposed in the channels of said channel members whereby said heads are supported by said trackway for independent sliding movement longitudinally thereof and with respect to each other, a plurality of horizontal bars each one of which is associated with one of said heads, vertically disposed pivot pins which are disposed in openings formed in portions of said bars and portions of said heads for pivotally attaching together the respective associated bars and heads, and a supporting member spaced from said trackway for supporting said bars for sliding movement longitudinally thereof, said heads and the bars associated therewith being movable to closely grouped positions to

collapse the structure and being spaced apart for use of the structure.

2. A drying rack for laundered articles including a trackway having opposed channels, a plurality of heads supported by said trackway for guided sliding movement longitudinally thereof with portions of said heads slidably disposed in said channels, each of said heads having an opening formed therethrough, a plurality of horizontal bars each one of which is associated with one of said heads with an end portion of each bar extended through the opening of its associated head, a vertically disposed pivot pin associated with each associated head and bar so that said pivot pin engages portions of said head and a portion of said bar to provide for pivotal movement of said bar with respect to said head, and a supporting member spaced from said trackway for supporting said bars for sliding movement longitudinally thereof.

3. A drying rack for laundered articles including a trackway comprising a pair of channel members arranged in vertically spaced relation with the channels thereof facing each other, a plurality of heads having opposed portions disposed in the channels of said channel members whereby said heads are supported by said trackway for sliding movement longitudinally thereof, each of said heads having an opening formed therethrough, a plurality of horizontal bars each one of which is associated with one of said heads with an end portion of each bar extended through the opening of its associated head, a vertically disposed pivot pin associated with each associated head and bar so that the pivot pin engages portions of said head and a portion of said bar to provide for pivotal movement of said bar with respect to said head, and a supporting member spaced from said trackway for supporting said bars for sliding movement longitudinally thereof.

4. A drying rack for laundered articles including a trackway comprising a pair of channel members arranged in vertically spaced relation with the channels thereof facing each other, a plurality of heads having opposed portions dis-

posed in the channels of said channel members whereby said heads are supported by said trackway for sliding movement longitudinally thereof, each of said heads having an opening formed therethrough, a plurality of horizontal bars each one of which is associated with one of said heads with an end portion of each bar extended through the opening of its associated head, a vertically disposed pivot pin associated with each associated head and bar so that the pivot pin engages portions of said head and a portion of said bar to provide for pivotal movement of said bar with respect to said head, the uppermost of said vertically spaced channel members of said trackway being provided with a cutaway portion through which said heads may be passed to associate said heads with or remove said heads from said trackway, and a supporting member spaced from said trackway for supporting said bars for sliding movement longitudinally thereof.

5. A drying rack for laundered articles including a trackway comprising a pair of channel members arranged in vertically spaced relation with the channels thereof facing each other, a plurality of heads having opposed portions disposed in the channels of said channel members whereby said heads are supported by said trackway for sliding movement longitudinally thereof, each of said heads having an opening formed therethrough, a plurality of horizontal bars each one of which is associated with one of said heads with an end portion of each bar extended through the opening of its associated head, tapered portions formed on the end portions of the bars which are extended through the openings of the heads associated with said bars, a vertically disposed pivot pin associated with each associated head and bar so that the pivot pin engages portions of said head and a portion of said bar to provide for pivotal movement of said bar with respect to said head, and a supporting member spaced from said trackway for supporting said bars for sliding movement longitudinally thereof.

CHARLES ADIN FOX.