

United States Patent [19]

[11] **3,729,611**

Vas

[45] **Apr. 24, 1973**

[54] **PLASMA GENERATOR** 3,200,233 8/1965 Anderson219/74
 [75] Inventor: **Alexandru Vas, Timisoara, Romania** 3,223,822 12/1965 Browning219/75 X
 [73] Assignee: **Centrul de Sudura Si Incercari La Oboseala Timisoara, Timisoara, Romania** 3,471,675 10/1969 Sargent et al.219/75
 2,569,661 3/1971 Ebeling et al.219/75 X

[22] Filed: **June 8, 1971**

[21] Appl. No.: **151,108**

Primary Examiner—J. V. Truhe
Assistant Examiner—Gale R. Peterson
Attorney—Karl F. Ross

Related U.S. Application Data

[63] Continuation-in-part of Ser. No. 721,843, April 16, 1968, Pat. No. 3,594,609.

[52] U.S. Cl.219/121 P, 313/231

[51] Int. Cl.B23k 15/00

[58] Field of Search.....219/121 P, 75, 121 R, 219/74; 313/161; 315/111

[57] ABSTRACT

A plasma generator with a hollow electrode connected to a venturi pump which draws a portion of the gas out of the arc chamber in a direction away from the workpiece to stabilize a molten-metal pool formed by the plasma generator. The withdrawn portion of the gas is recycled to the region around the plasma arc between the arc chamber and the workpiece.

[56] References Cited

UNITED STATES PATENTS

3,010,009 11/1961 Ducati.....219/121 P

2 Claims, 1 Drawing Figure

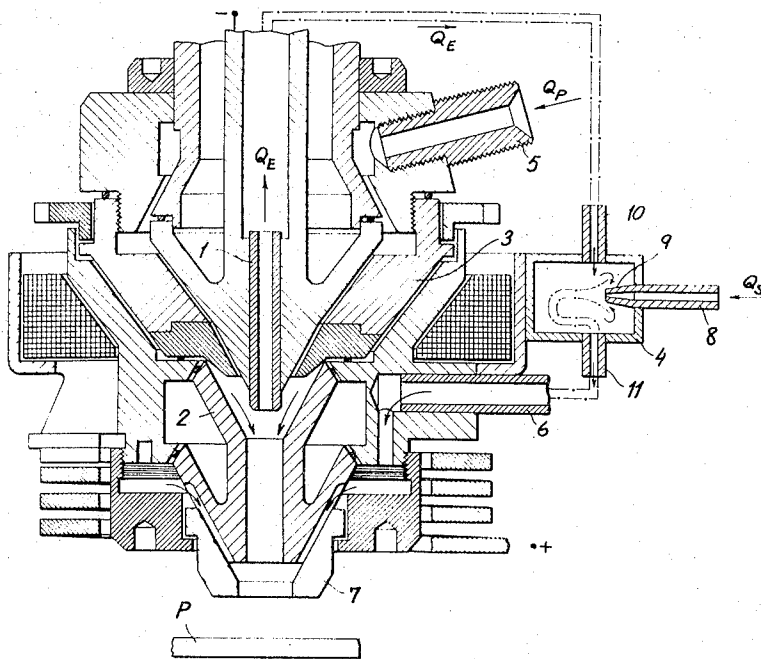

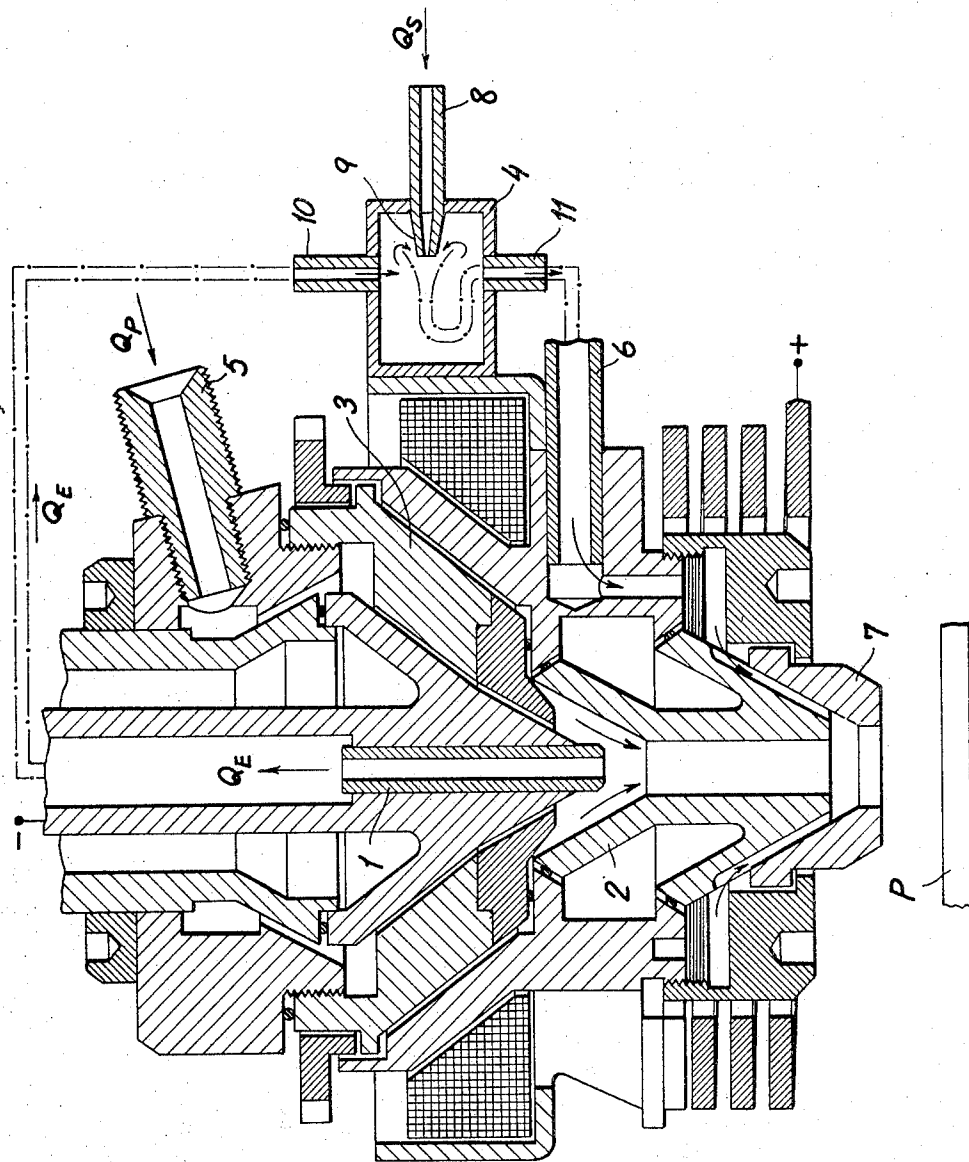

PLASMA GENERATOR

CROSS-REFERENCE TO RELATED APPLICATION

This application is a continuation-in-part of my application Ser. No. 721,843 filed Apr. 16, 1968 and issued July 20, 1971 as U.S. Pat. No. 3,594,609.

FIELD OF THE INVENTION

The present invention relates to improvements in plasma generators of the type described in the above-identified application and particularly to improved plasma generators with magnetic focusing of the plasma and means for admitting supplemental gases to the arc chamber. The invention also relates to improved plasma generators for cutting and welding metals and for coating materials with metal, for metallization and for chemical reactions at high temperatures in the metallurgical industries.

BACKGROUND OF THE INVENTION

Plasma generators of various types have been proposed heretofore, such generators generally comprising a nozzle through which a gas is induced to flow and an electrode arrangement for ionizing the gas and converting the same into a plasma. The system may use a transferred arc or a completely internal arc and is generally connected to a source of gas at high pressure.

The mechanical forces at the nozzle, as a consequence of high-gas velocity, often give rise to instability of a metal pool formed by the plasma generator during welding or the like. Such high axial forces may be required where metal cutting is desired but represents a disadvantage where welding, metal cutting or the like using a pool of metal is desired. It should also be mentioned that it is known to provide tubular electrodes in a plasma generator, mainly for introducing additives to the plasma stream.

OBJECT OF THE INVENTION

It is the principal object of the present invention to provide a plasma generator which is more versatile and effective than the plasma generator described in my prior application and which also is able to overcome the disadvantages of prior-art plasma generators as described above.

SUMMARY OF THE INVENTION

This object and others which will become apparent hereinafter are attained in a plasma generator which, except as modified as described below, will have the configuration and operating modalities of the plasma generator described in the aforementioned copending application. I have now found that it is possible to stabilize the metal pool formed by the plasma generator when the latter is not used for cutting, e.g., to obtain a stable metal bath for welding, coating, remelting, alloy . . . , by reducing the axial velocity of the jet emerging from the arc chamber of the plasma generator, especially by inducing a low-pressure drop in this chamber at the electrode tip. More specifically, I provide the electrode as a tubular member through which a portion of a plasmogen gas is induced to flow in a direction opposite the plasma jet and from the axial zone of the arc chamber by an external ejector (venturi pump) connected to the tubular electrode. The extracted gas is

then reintroduced into the nozzle in an exit zone thereof between the nozzle member defining the outlet from the arc chamber and an annular piece which covers this nozzle and defines an angular space therewith. This space may also be used to introduce a metal powder when metallization is effected.

DESCRIPTION OF THE DRAWING

The above and other objects, features and advantages of the present invention will become more readily apparent from the following description, reference being made to the accompanying drawing at which the sole FIGURE is an axial cross-sectional view of the nozzle region of a plasma generator according to the present invention.

SPECIFIC DESCRIPTION

The plasma generator illustrated in the drawing comprises a tubular electrode 1 and a nozzle body 2 supported with respect to one another by a ceramic insulator 3. When the electrode 1 is replaced by a solid rod, the apparatus can be used for metal cutting with high jet velocity. When, however, the nozzle is tubular as illustrated, e.g., for welding with a stable metal pool, it is connected to the inlet 10 of a venturi ejector (venturi pump) represented at 4 and located externally of the generator on a suitable bracket as illustrated.

When the ejector 4 is operative, a portion of the plasmogen gas Q_p , introduced via the coupling 5 and passing through the nozzle chamber 2 as represented by the arrows, is withdrawn and is represented by the gas portion Q_e .

From the venturi pump 4, the gas Q_e is introduced via a fitting 6 into the space between the nozzle 2 and an annular piece 7, the nozzle and this angular piece 7 defining a downwardly converging annular chamber so that the gas emerging therefrom focuses upon the imaginary conical apex which lies at the axis of the generator and the pool. Because of the reduced pressure in the arc chamber (i.e., the chamber of member 3 in which an arc is struck between the electrode 1 and member 2), the axial velocity of the plasma arc or jet is reduced and impinges upon the workpiece P with reduced force. As a consequence, the hot metal bath remains stable. Of course, when the system is operating with a transferred arc, the arc passes from member 2 to the workpiece P.

When the plasma generator is used for alloying, metal powder is introduced into the plasma arc together with a supplementary gas Q_s . The powder is thus carried by the gas traversing the space between piece 7 and nozzle 2. When the generator is used for chemical reactions or metallization, gas subject to the reaction or metallization powder can be introduced at the top of electrode 1 or through fitting 6 or both.

The venturi pump (ejector) 4 comprises a nozzle 8 through which the supplementary gas portion Q_s is introduced. Around the nozzle, in accordance with the venturi principle, a low pressure is produced at 9, thereby drawing gas in through fitting 10. The gas then flows through outlet 11 into fitting 6.

I claim:

1. A plasma-arc generator comprising: a housing structure;

3

4

a nozzle received in said housing structure and having a mouth adapted to be trained against a workpiece;

a tubular electrode mounted in said housing structure and extending axially toward said nozzle while defining an arc chamber therewith for generating a plasma therein;

means communicating with said arc chamber for introducing a plasmogen gas thereto for conversion into a plasma and projection through said nozzle as a plasma jet against said workpiece;

an annular piece spacedly surrounding said nozzle at the mouth thereof to define an annular compartment opening inwardly toward said workpiece;

5

10

15

20

25

30

35

40

45

50

55

60

65

and

a venturi pump connected to said electrode and to said annular chamber for inducing a portion of the plasmogen gas to flow away from said mouth and said workpiece through said electrode in said arc chamber and thereafter returning said portion through said annular chamber, thereby reducing the velocity of said jet.

2. The plasma-arc generator defined in claim 1, further comprising means for introducing metal powder into said annular chamber for metallizing said workpiece.

* * * * *