



(11) **EP 2 573 623 B1**

(12) **EUROPEAN PATENT SPECIFICATION**

(45) Date of publication and mention of the grant of the patent:
23.11.2016 Bulletin 2016/47

(51) Int Cl.:
G03G 15/00 (2006.01)

(21) Application number: **11182394.4**

(22) Date of filing: **22.09.2011**

(54) **Method and apparatus for enveloping printed sheets**

Verfahren und Vorrichtung zum Einwickeln von bedruckten Blättern

Appareil et procédé pour envelopper des feuilles imprimées

(84) Designated Contracting States:
AL AT BE BG CH CY CZ DE DK EE ES FI FR GB GR HR HU IE IS IT LI LT LU LV MC MK MT NL NO PL PT RO RS SE SI SK SM TR

(43) Date of publication of application:
27.03.2013 Bulletin 2013/13

(73) Proprietors:
• **Segelberg, Tommy**
186 55 Vallentuna (SE)
• **SWARTZ, Per, Gunnar**
S-131 47 Nacka (SE)
• **Mejdahl, Jonny**
131 46 Nacka (SE)

(72) Inventors:
• **Segelberg, Tommy**
186 55 Vallentuna (SE)
• **Swartz, Per**
134 38 Gustavsberg (SE)
• **Mejdahl, Jonny**
131 46 Nacka (SE)

(74) Representative: **Platt, Timothy Nathaniel**
IPQ IP Specialists AB
Docketing
PO Box 42
683 21 Hagfors (SE)

(56) References cited:
EP-A1- 2 316 661 US-A1- 2003 234 282
US-A1- 2011 220 557 US-B1- 6 980 767

EP 2 573 623 B1

Note: Within nine months of the publication of the mention of the grant of the European patent in the European Patent Bulletin, any person may give notice to the European Patent Office of opposition to that patent, in accordance with the Implementing Regulations. Notice of opposition shall not be deemed to have been filed until the opposition fee has been paid. (Art. 99(1) European Patent Convention).

Description

Technical Field

[0001] The present invention relates to a method and apparatus for enveloping printed sheets. The present invention relates to a method according to the preamble to Claim 1, to an system according to the preamble of Claim 6. The method and apparatus are particularly well suited to use in or with a standard printer, having multiple standard trays carrying standard paper of different formats.

Background Art

[0002] Xerox Disclosure Journal Vol. 14, No. 6, November/December 1989, 315 in an article entitled Toner Gluing, describes the use of toner to glue together two paper surfaces. This makes possible the creation of an envelope from two sheets of paper, one provided with a border of toner, whereafter pressure and heat are applied to create the seal.

[0003] Such a solution sealing multiple sheets to each other by heating and/or pressing together toner borders on the sheets is shown in WO 96/09935.

[0004] EP 0 514 699 A1 describes a system where a toner border is applied to a paper sheet, is heated and then folded and then forced through heated rollers, thereby providing a sealed document.

[0005] US-A-2011/220557 discloses an enveloping system where sheets are inserted into envelopes and each envelope including sheets is weighed and sorted based on the weight. US-A-6980767 describes a printer where two or more sheets are joined together by using toner strips.

[0006] US-A-2003/234282 describes the forming of an envelope from a single standard size sheet with a sealing mechanism such as knurling or crimping.

[0007] Such previously known solutions do not provided for the automatic printing of both the envelope and sheets to be enclosed in the envelope. The previously known solutions do not achieve this in a standard laser-jet printer, nor do they provide automatic assurance that the correct contents are enclosed in the envelope. Previously known solutions have required several lines, separate envelope blank feeders and coding means to make sure that the correct contents are enclosed in the correct envelope. These and other shortcomings of the previously known solutions are remedied with a method and an apparatus of the type described by way of introduction which have the characterizing features of the main claims. The present invention provides a very cost effective solution which utilizes an existing standard printer with standard grade paper of standard sizes.

Brief Description of Drawings

[0008] The present invention will be described in the

following with reference to the drawings of which, Fig. 1 shows schematically how the present invention could be realized in one embodiment using standard paper sizes printed. A paper sheet 1 of size A3+ in this specific example is printed in a standard laser printer with a toner border 4 on the side facing the viewer. A text 6 is also printed on the same side. The reverse side of the A3+ sheet can be provided with an address for example, as indicated by the address "SENATUM POPULUMQUE ROMANUM" 2 visible in reverse. It is of course possible to print any texts available with a standard duplex printer. The numeral 5 indicates printed standard A4 sheets of any reasonable number which are to be enclosed in the envelope created from the A3+ sheet 1 in this example, by folding along the crease 3, whereupon the toner border will adhere to itself and seal the envelope, as will be described below.

[0009] One particularly advantageous embodiment of the method and apparatus of the present invention is illustrated schematically in Fig. 2, which shows a standard duplex laser printer 7, which in many cases today is a copier and a scanner as well. The printer 7 is provided in this case with a number of trays 8, 9, 10 and 11 for different sheets of standard paper, in this case, for example, tray 11 may contain standard A3+ paper (329 x 483 mm) and tray 10 may contain standard A4 paper (210 x 297 mm). In the process according to the invention an A3+ sheet is duplex printed on one side with an address, return address and/or other desired text and the other side is printed with a toner border frame 4 (see Fig. 1) as well as any desired text, for example the salutation "Ave, Amici et Senatori" 6 in Fig. 1. Any large A3+ sheet is automatically guided after printing and is fed out downwards in the figure (arrow 13) to rollers 14 and 16, which crease it at crease line 3 and feed it upwards to a collecting station. The filler, i.e. and desired printed A4 sheets 5 are then printed one by one on both sides (Here with the bread text "Gallia est omnis divisa") and are fed individually (arrow 12) and stacked at the collecting station above the roller 14 in the figure here. When all the desired A4 sheets have been printed and collected, the stack is fed into the crease of the waiting A3+ sheet and the complete packet is fed (arrow 17) through between the rollers 15 and 16, which will press the toner border sections against each other thereby sealing the entire envelope with the printed A4 sheets inside. The sealed envelope 1 b with contents 5b can be seen to the right in Fig. 2. The rollers may be heated to increase the sealing effect but this is not at all necessary for the invention.

[0010] One important advantage of the method and apparatus of the present invention is that, since a single standard duplex printer is used to produce both the printed envelope 1 b and the printed sheet contents 5b, this makes it possible to guarantee that the correct contents are inserted into the correct envelope. Previously known enveloping methods and apparatuses have had to rely on numbered envelopes and contents to make sure that

the correct contents have been inserted into the proper envelope, thus adding extra steps to the process and still not eliminating the risk of mismatched contents.

[0011] With the present method it is possible to produce finished printed enveloped packets at a very rapid rate, with assured correct contents, with a standard laser printer, since both the envelope with printed text, address etc, as well as toner adhesive edges, and the printed content sheets are produced by single standard printer in a single sequence. First the A3+ sheet is printed with the address 2 on one side and the toner edges 4 and possibly a printed text 6 on the other, and it is advanced to the creasing and pausing station by the rolls 14 and 16, while the A4 content sheets 5 are printed and collected. When the content sheets are completely printed and collected, the stack 5 is advanced toward the crease 3 in the waiting printed A3+ sheet and the entire folded packet is pressed forward through the rollers 16 and 17 sealing the toner edges 4 to each other. The laser printer signal for starting the printing of the next A3+ envelope sheet is simultaneous with the signal to advance the stack of printed A4 content sheets 5 towards its waiting creased A3+ sheet. There is thus a completely continuous printing process at the maximum rate for the printer.

[0012] It should be emphasized that this is merely one method, apparatus and printer for realizing the present invention. Other dimensions and grades of non-standard paper can also be used according to the invention with advantage. It is also envisioned that the enveloping method can easily be combined with a perforation step to facilitate opening the delivered missive. The apparatus can easily be incorporated and built into a printer at its output.

Claims

1. Method for creating a sealed envelope (1 b) from a laser printed sheet (1), comprising:

- a. Printing (6, 2) in a printer (7) a standard envelope-width printed sheet (1) with printed toner borders (4) along its edges,
- b. feeding out (13) from the printer (7) said standard envelope-width printed sheet (1)
- c. creasing (3) said standard envelope-width printed sheet (1),
- d. folding over (17) said standard envelope-width printed sheet (1), bringing said toner borders (4) into mutual contact,
- e. applying pressure to the toner borders (4) in mutual contact, sealing the folded printed sheet into an envelope (17),

characterized by the additional steps of:

- f. halting advance of the standard envelope-width printed sheet (1) after feeding out (13) from the printer,

g. printing and collecting from the printer one or more insert sheets (5) having a transverse dimension smaller than the width between the toner borders (4) on the envelope-width printed sheet (1),

h. inserting said collected insert sheets (5b) as the standard envelope width printed sheet is folded, completely avoiding contact with the toner borders, which are folded against each other.

2. Method for creating a sealed envelope according to Claim 1, **characterized by** the additional step of:

g. Pressure sealing the toner borders folded against each other.

3. Method for creating a sealed envelope according to Claim 1, **characterized in that** feed out (13) from the printer (7) of a standard envelope-width printed sheet triggers the insertion of collected insert sheets (5b) into a preceding envelope width printed sheet (1) being folded.

4. Method for creating a sealed envelope according to Claim 1, **characterized in that** the printer (7) is a duplex printer and text is provided in the printer (7) on both sides of the printed sheet.

5. Method for creating a sealed envelope according to Claim 1, **characterized by** the further step of perforating tear indications around three edges of the sealed envelope (1 b).

6. Printing and enveloping system comprising an enveloping apparatus and a printer having a plurality of paper trays of standard rectangular dimensions, containing at least standard rectangular envelope-width sheets and standard smaller width sheets **characterized by**:

a. Roller means for advancing (13), holding (14, 16) and transverse creasing (3) one of said standard rectangular envelope-width sheets (1), printed with toner borders (4), when fed out of said printer (7)

b. Collecting means for collecting, when fed out of said printer, printed standard smaller width sheets (5) of a width smaller than the width between said toner borders (4),

c. Inserting means for inserting said collection of printer standard smaller width sheets into the crease in the printed standard-width sheet, as the printed standard-width sheet is folded, completely avoiding contact with the toner borders (4) on the printed standard-width sheets.

d. Roller means (15, 16) for pressing together folded over toner borders (4) against each other, applying pressure to the toner borders in mutual

contact, sealing the folded printed standard-width sheet into an envelope .

7. Printing and enveloping system according to Claim 6, **characterized in that** said means for pressing together the folded toner borders against each other comprise heated rollers (15, 16), providing enhanced sealing effect to the toner.

8. Printing and enveloping system according to Claim 6, comprising an enveloping apparatus and a standard multi-tray printer having a plurality of paper trays of standard rectangular dimensions, containing at least standard A3+ rectangular envelope-width sheets and standard smaller width A4 sheets **characterized in that:**

said standard envelope width sheets are standard A3+ sheets and said smaller standard size rectangular printed sheets (5) are standard A4 sheets.

Patentansprüche

1. Verfahren zum Erzeugen eines versiegelten Umschlags (1b) aus einem laserbedruckten Blatt (1), umfassend:

- a. Drucken (6, 2) eines standardumschlagbreiten bedruckten Blattes (1) mit gedruckten Tonerrändern (4) entlang seinen Kanten in einem Drucker (7),
- b. Herausführen (13) des standardumschlagbreiten bedruckten Blattes (1) aus dem Drucker (7)
- c. Falzen (3) des standardumschlagbreiten bedruckten Blattes (1),
- d. Zusammenfalten (17) des standardumschlagbreiten bedruckten Blattes (1), so dass die Tonerränder (4) in gegenseitigen Kontakt gebracht werden,
- e. Anwenden von Druck auf die Tonerränder (4), die in gegenseitigem Kontakt sind, so dass das gefaltete bedruckte Blatt in einen Umschlag (17) versiegelt wird,

gekennzeichnet durch die zusätzlichen Schritte von:

- f. Anhalten des Vorwärtsbewegens des standardumschlagbreiten bedruckten Blattes (1) nach dem Herausführen (13) aus dem Drucker,
- g. Drucken und Sammeln eines oder mehrerer Einlegeblätter (5), die eine Querabmessung kleiner als die Breite zwischen den Tonerrändern (4) auf dem umschlagbreiten bedruckten Blatt (1) aufweisen, von dem Drucker,

h. Einlegen der gesammelten Einlegeblätter (5b), wenn das standardumschlagbreite bedruckte Blatt gefaltet wird, wobei Kontakt mit den Tonerrändern, die gegeneinander gefaltet werden, vollständig vermieden wird.

2. Verfahren zum Erzeugen eines versiegelten Umschlags gemäß Anspruch 1, **gekennzeichnet durch** den zusätzlichen Schritt von:

g. Druckversiegeln der gegeneinander gefalteten Tonerränder.

3. Verfahren zum Erzeugen eines versiegelten Umschlags gemäß Anspruch 1, **dadurch gekennzeichnet, dass** das Herausführen (13) eines standardumschlagbreiten bedruckten Blattes aus dem Drucker (7) das Einlegen gesammelter Einlegeblätter (5b) in ein vorheriges umschlagbreites bedrucktes Blatt (1), das gefaltet wird, auslöst.

4. Verfahren zum Erzeugen eines versiegelten Umschlags gemäß Anspruch 1, **dadurch gekennzeichnet, dass** der Drucker (7) ein Duplexdrucker ist und in dem Drucker (7) Text auf beiden Seiten des bedruckten Blattes bereitgestellt wird.

5. Verfahren zum Erzeugen eines versiegelten Umschlags gemäß Anspruch 1, **gekennzeichnet durch** den weiteren Schritt des Perforierens von Rissmarkierungen um drei Kanten des versiegelten Umschlags (1b).

6. Druck- und Umschlagformsystem umfassend eine Umschlagformvorrichtung und einen Drucker, der mehrere Papierschächte mit Standard-Rechteckabmessungen aufweist, die zumindest standardumschlagbreite Rechteckblätter (1) und Standardblätter mit kleinerer Breite enthalten, **gekennzeichnet durch:**

a. Walzenmittel zum Vorwärtsbewegen (13), Halten (14, 16) und Querfalzen (3) eines der mit Tonerrändern (4) bedruckten standardumschlagbreiten Rechteckblätter (1), wenn es aus dem Drucker (7) herausgeführt wird

b. Sammelmittel zum Sammeln bedruckter Standardblätter (5) mit kleinerer Breite, die eine kleinere Breite aufweisen als die Breite zwischen den Tonerrändern (4), wenn sie aus dem Drucker herausgeführt werden,

c. Einlegemittel zum Einlegen der Sammlung bedruckter Standardblätter mit kleinerer Breite in den Falz in dem bedruckten standardbreiten Blatt, wenn das bedruckte standardbreite Blatt gefaltet wird, wobei Kontakt mit den Tonerrändern (4) an den gedruckten standardbreiten Blättern vollständig vermieden wird.

d. Walzenmittel (15, 16) zum Zusammendrücken gegeneinander zusammengefalteter Tonerränder (4), wobei auf die Tonerränder, die in gegenseitigem Kontakt sind, Druck angewandt wird, so dass das gefaltete bedruckte standardbreite Blatt in einen Umschlag versiegelt wird.

7. Druck- und Umschlagformsystem gemäß Anspruch 6, **dadurch gekennzeichnet, dass** die Mittel zum Zusammendrücken der gegeneinander gefalteten Tonerränder erhitze Walzen (15, 16) umfassen, die einen erhöhten Versiegelungseffekt für den Toner bereitstellen.

8. Druck- und Umschlagformsystem gemäß Anspruch 6, umfassend eine Umschlagformvorrichtung und einen Standardmultischachtdrucker, der mehrere Papierschächte mit Standard-Rechteckabmessungen aufweist, die zumindest A3+- standardumschlagbreite Rechteckblätter und Blätter mit kleinerer A4-Standardbreite enthalten, **dadurch gekennzeichnet, dass:**

die standardumschlagbreiten Blätter A3+-Standardblätter sind und die bedruckten Rechteckblätter (5) mit kleinerer Standardgröße A4-Standardblätter sind.

Revendications

1. Procédé pour créer une enveloppe scellée (1b) à partir d'une feuille (1) imprimée par impression laser, comprenant :

- a. le fait d'imprimer (6, 2) dans une imprimante (7) une feuille imprimée standard (1) à largeur d'enveloppe, avec des bordures en toner imprimées (4) le long de ses bords,
- b. le fait de laisser sortir (13) de l'imprimante (7) ladite feuille imprimée standard (1) à largeur d'enveloppe,
- c. le fait de rainer (3) ladite feuille imprimée standard (1) à largeur d'enveloppe,
- d. le fait de replier (17) ladite feuille imprimée standard (1) à largeur d'enveloppe, de façon à amener lesdites bordures en toner (4) en contact mutuel,
- e. le fait d'appliquer une pression sur les bordures en toner (4) en contact mutuel, de façon à fixer la feuille imprimée sous la forme d'une enveloppe (17),

caractérisé par les étapes supplémentaires consistant dans :

- f. le fait d'arrêter l'avance de la feuille imprimée

standard (1) à largeur d'enveloppe après la sortie (13) hors de l'imprimante,

g. le fait d'imprimer et de collecter depuis l'imprimante une ou plusieurs feuilles (5) à insérer ayant une dimension transversale inférieure à la largeur située entre les bordures en toner (4) présentes sur la feuille imprimée standard (1) à largeur d'enveloppe,

h. le fait d'insérer lesdites feuilles à insérer (5b) collectées lorsque la feuille imprimée standard (1) à largeur d'enveloppe est pliée, en évitant complètement tout contact avec les bordures en toner, qui sont repliées les unes contre les autres.

2. Procédé pour créer une enveloppe scellée selon la revendication 1, **caractérisé par** l'étape supplémentaire consistant dans :

g. le fait de faire adhérer par pression les bordures en toner repliées les unes contre les autres.

3. Procédé pour créer d'une enveloppe scellée selon la revendication 1, **caractérisé en ce que** la sortie (13) depuis l'imprimante (7) d'une feuille imprimée standard à largeur d'enveloppe déclenche l'insertion de feuilles à insérer (5b) collectées dans une feuille imprimée à largeur d'enveloppe précédente qui est pliée.

4. Procédé pour créer une enveloppe scellée selon la revendication 1, **caractérisé en ce que** l'imprimante (7) est une imprimante recto-verso et **en ce que** du texte est fourni dans l'imprimante (7) sur les deux côtés de la feuille imprimée.

5. Procédé pour créer une enveloppe scellée selon la revendication 1, **caractérisé par** l'étape supplémentaire consistant à perforer des indications de déchirure autour de trois bords de l'enveloppe scellée (1b).

6. Système d'impression et de mise sous enveloppe comprenant un appareil de mise sous enveloppe et une imprimante ayant une pluralité de bacs à papier de dimensions rectangulaires standard, contenant au moins des feuilles rectangulaires standard à largeur d'enveloppe et des feuilles standard de largeur plus petite, **caractérisé par** :

- a. des moyens formant rouleaux pour faire avancer (13), maintenir (14, 16) et rainer transversalement (3), une desdites feuilles standard rectangulaire (1) à largeur d'enveloppe, qui est imprimée avec des bordures en toner (4), lorsqu'elle est délivrée par ladite imprimante (7),
- b. des moyens de collecte pour collecter, lors-

- qu'elles sont délivrées par ladite imprimante, des feuilles imprimées (5) de largeur standard plus petite, d'une largeur inférieure à la largeur s'étendant entre lesdites bordures en toner (4),
- c. des moyens d'insertion pour insérer lesdites feuilles imprimées collectées de largeur standard plus petite dans le pli présent dans la feuille imprimée de largeur standard, lorsque la feuille imprimée de largeur standard est pliée, de façon à éviter complètement le contact avec les bordures en toner (4) présentes sur les feuilles imprimées de largeur standard,
- d. des moyens formant rouleaux (15, 16) pour presser ensemble les bordures en toner (4) repliées les unes contre les autres, en appliquant une pression sur les bordures en toner en contact mutuel, scellant la feuille imprimée pliée de largeur standard sous la forme d'une enveloppe.
7. Système d'impression et de mise sous enveloppe selon la revendication 6, **caractérisé en ce que** lesdits moyens pour presser ensemble les bordures en toner repliées les unes contre les autres comprennent des rouleaux (15, 16) chauffés, fournissant au toner un effet de scellage augmenté.
8. Système d'impression et de mise sous enveloppe selon la revendication 6, comprenant un appareil de mise sous enveloppe et une imprimante multi-bac standard comportant une pluralité de bacs à papier de dimensions rectangulaires standard, contenant au moins des feuilles rectangulaires de format A3 + à largeur d'enveloppe et des feuilles de format A4 de largeur plus petite, **caractérisé en ce que :**
- lesdites feuilles standard à largeur d'enveloppe sont des feuilles de format A3 + et lesdites feuilles imprimées (5) rectangulaires standard plus petites sont des feuilles de format A4.

5

10

15

20

25

30

35

40

45

50

55

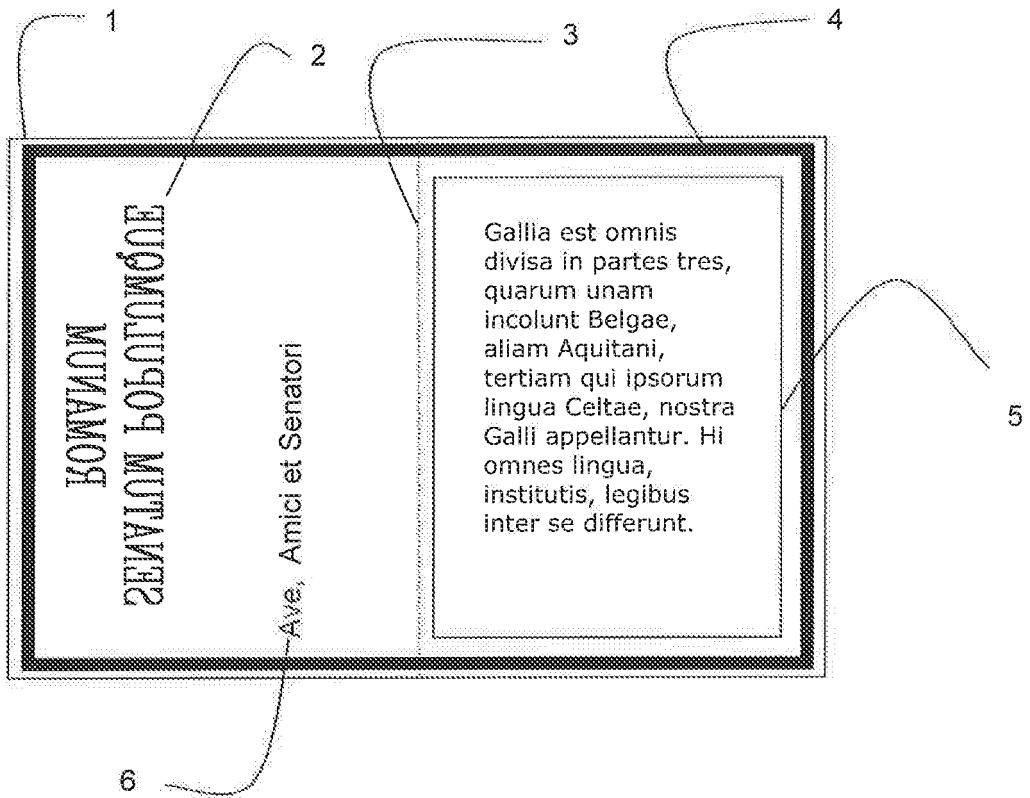

Fig. 1

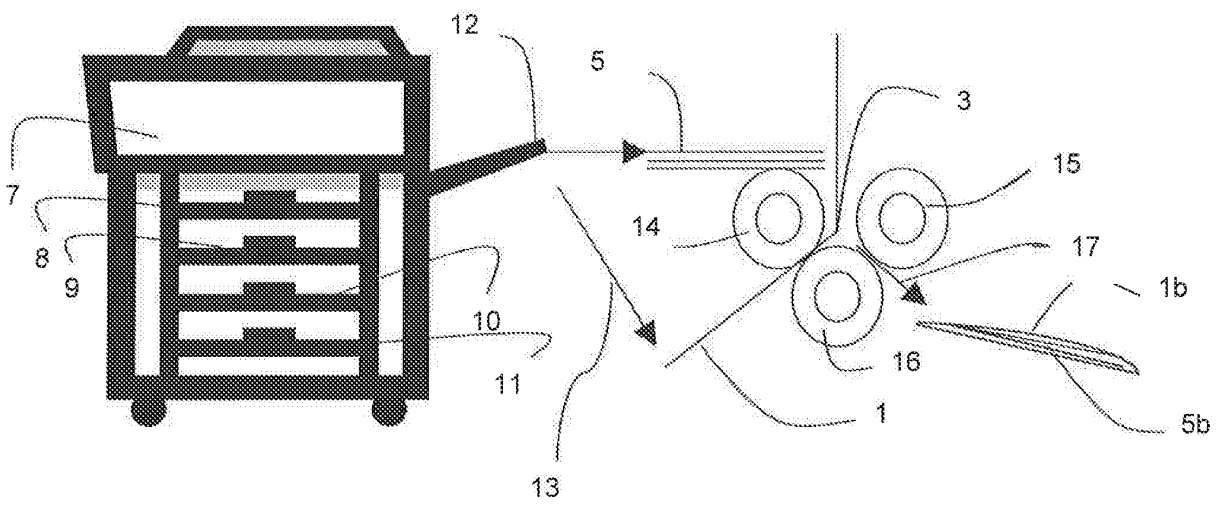

Fig. 2

REFERENCES CITED IN THE DESCRIPTION

This list of references cited by the applicant is for the reader's convenience only. It does not form part of the European patent document. Even though great care has been taken in compiling the references, errors or omissions cannot be excluded and the EPO disclaims all liability in this regard.

Patent documents cited in the description

- WO 9609935 A [0003]
- EP 0514699 A1 [0004]
- US 2011220557 A [0005]
- US 6980767 A [0005]
- US 2003234282 A [0006]

Non-patent literature cited in the description

- Xerox Disclosure Journal. *Toner Gluing*, November 1989, vol. 14 (6), 315 [0002]