

(19) World Intellectual Property Organization
International Bureau



(43) International Publication Date
17 November 2005 (17.11.2005)

PCT

(10) International Publication Number
WO 2005/108180 A1

- (51) International Patent Classification⁷: **B60V 1/16**
- (21) International Application Number:
PCT/US2005/012127
- (22) International Filing Date: 11 April 2005 (11.04.2005)
- (25) Filing Language: English
- (26) Publication Language: English
- (30) Priority Data:
10/832,198 26 April 2004 (26.04.2004) US
- (71) Applicant (for all designated States except US): **TEXTRON INC.** [US/US]; 19401 Chef Menteur Highway, New Orleans, LA 70129 (US).
- (72) Inventors: **DUBOSE, Keith, W.**; 14146 River Road, Pensacola, FL 32507 (US). **MAGNUSEN, Kirk, A.**; 306 Robin Lane, Slidell, LA 70458-1636 (US).
- (74) Agents: **GRODT, Thomas, P.** et al.; Textron Systems Corporation, 201 Lowell Street, Wilmington, MA 01887 (US).
- (81) Designated States (unless otherwise indicated, for every kind of national protection available): AE, AG, AL, AM,

AT, AU, AZ, BA, BB, BG, BR, BW, BY, BZ, CA, CH, CN, CO, CR, CU, CZ, DE, DK, DM, DZ, EC, EE, EG, ES, FI, GB, GD, GE, GH, GM, HR, HU, ID, IL, IN, IS, JP, KE, KG, KM, KP, KR, KZ, LC, LK, LR, LS, LT, LU, LV, MA, MD, MG, MK, MN, MW, MX, MZ, NA, NI, NO, NZ, OM, PG, PH, PL, PT, RO, RU, SC, SD, SE, SG, SK, SL, SM, SY, TJ, TM, TN, TR, TT, TZ, UA, UG, US, UZ, VC, VN, YU, ZA, ZM, ZW.

(84) Designated States (unless otherwise indicated, for every kind of regional protection available): ARIPO (BW, GH, GM, KE, LS, MW, MZ, NA, SD, SL, SZ, TZ, UG, ZM, ZW), Eurasian (AM, AZ, BY, KG, KZ, MD, RU, TJ, TM), European (AT, BE, BG, CH, CY, CZ, DE, DK, EE, ES, FI, FR, GB, GR, HU, IE, IS, IT, LT, LU, MC, NL, PL, PT, RO, SE, SI, SK, TR), OAPI (BF, BJ, CF, CG, CI, CM, GA, GN, GQ, GW, ML, MR, NE, SN, TD, TG).

Declaration under Rule 4.17:

— as to applicant's entitlement to apply for and be granted a patent (Rule 4.17(ii)) for all designations

Published:

— with international search report

[Continued on next page]



WO 2005/108180 A1

(54) Title: WRAPPED-CONE FINGERS FOR SKIRT SYSTEMS

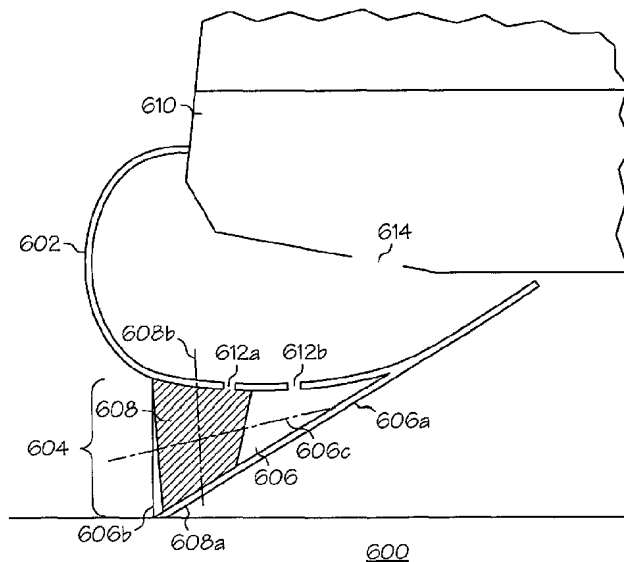

(57) Abstract: Wrapped-cone fingers (604) for use in an air-cushion vehicle (ACV) skirt system are described. Wrapped-cone fingers (604) may include an inner cone (608) that is "wrapped" or generally enclosed by an outer finger (606). The inner cone (608) may include an inner cone opening (612A) through which air may travel. The outer finger (606) may include a back face opening (606b). When inflated, the inner cone (608) blocks the back face opening (606b) in the outer finger (606), allowing for increased air pressure in the outer finger (606) and thus inflating the inner cone (608) and outer finger (606) of the wrapped-cone finger (604). Wrapped-cone fingers according to the present invention may be lightweight, inexpensive and resistant to scooping and snagging. Embodiments are also directed to ACV skirt systems and methods of manufacturing wrapped-cone fingers for use with an ACV skirt system.



For two-letter codes and other abbreviations, refer to the "Guidance Notes on Codes and Abbreviations" appearing at the beginning of each regular issue of the PCT Gazette.

WRAPPED-CONE FINGERS FOR SKIRT SYSTEMS

BACKGROUND

5 Hovercraft or air-cushion vehicles (ACVs) are commonly used to transport passengers and cargo over variable terrain including water, snow, and land. ACVs typically use a skirt system to contain a volume of air, or "air cushion," which supports the weight of the vehicle during operation. An ACV skirt system commonly includes a skirt bag and multiple smaller cells or "fingers" that are adjacent to one another and located around the lower periphery of
10 the skirt bag. The skirt bag forms a boundary or curtain around the perimeter of the ACV hull to contain the air cushion. The fingers help to form an air cushion seal between the skirt bag and the underlying terrain, e.g., land or water.

FIG. 1 shows a perspective view of the underside of a representative hovercraft or ACV
15 including a prior art skirt system **100** with direction of forward travel **1** toward the ACV bow indicated. The prior art skirt system **100** includes a peripheral bag or skirt bag **106** and fingers **110**. The skirt bag **106** is attached to the periphery of the underside of an ACV hull **102**. The hull **102** may be attached to a deck **108** as shown. The skirt bag **106** may include bow **106a**, port **106b**, stern **106c**, and starboard **106d** sections.

20 The design of a finger **110** may vary, depending on the location of a particular finger on the perimeter of the skirt bag **106**. Different finger designs may help to maintain the air cushion as the ACV moves in various directions and over different types of surfaces and terrain. For example, an open-cone or open-finger design is commonly used for fingers **110a** located at
25 the bow section **106a** and side sections **106b**, **106d** of the skirt bag **106**. An open finger **110a** may include an open loop or cone of flexible material that is attached to the peripheral bag **106** along a perimeter. For further example, a closed-cone or closed-finger design is commonly used for fingers located at the stern and stern corner locations of a skirt system, e.g., skirt system **100**. Closed fingers **110b** may include a closed loop or cone of flexible
30 material, forming a substantially closed air cell or compartment.

The skirt bag **106** is typically inflated through ports or feed ducts that are supplied with air by one or more fans located on the deck **108**. The fingers **110** are typically inflated with air from the skirt bag and/or air from the air cushion. Feed holes in the skirt bag may supply air

to closed fingers. Open fingers are open to and receive a supply of air from the air cushion. Open fingers may also have local feed holes supplying air from the skirt bag to facilitate inflation.

5 FIG. 2 shows a profile of a prior art skirt system **200** including a skirt bag **202** connected to a portion of an ACV hull **206**. A finger **204** is attached to the skirt bag **202**. The direction of the bow of the ACV is indicated **1**. The finger **204** is shown as a conventional closed finger design and would normally be located at the stern or stern corners of a skirt bag. The finger **204** may include a leading face or edge **204a** and a swept-back finger or cone portion **204b**
10 that is formed by the looped edge of the finger or cone material. The leading edge **204a** may face in a desired direction relative to the skirt and ACV hull, depending on the type of finger and its location on the skirt bag **202**, e.g., toward the bow **1** or towards the port and starboard directions. The leading edge **204a** may form a leading edge angle **208** with the underlying terrain or sea surface **10** as shown. The finger **204** design shown may sometimes be referred
15 to as a “swept-back cone” design, in reference to the finger resembling a cone of fabric or flexible material that has been cut in half.

With continued reference to FIG. 2, the stern finger **204** is attached to the skirt bag **202** at an attachment perimeter **214** (only one portion of the attachment perimeter is shown). One of
20 skill in the art will understand that the attachment perimeter **214** will typically have an open-ended shape for an open finger design, e.g., in the shape of the letter “U” or an open oval shape. For a closed finger design, an aft panel forming a back face **204c** would normally be included to seal the swept-back cone portion **204b**.

25 FIG. 3 shows a profile of the prior art skirt system **200** of FIG. 2 with a conventional closed finger **204** that is in a collapsed position. Closed fingers **204** may collapse in certain situations, such as when a water wave **10** impacts the leading edge **204a** of the finger **204**. When the pressure and forces on the leading edge **204a** exceed the counter pressure and force of the air inside the finger **204**, the leading edge **204a** can become turned inside out thereby
30 creating a scoop **214**, e.g., a concave surface with an included angle, as shown.

The creation of a scoop **214** is sometimes referred to as “scooping”. When scooping occurs in one or more close fingers, large water-generated forces or water loads can result in a degradation in ACV performance and ultimately either a material or attachment structural

failure to a finger and/or adjacent skirt structure. These types of failures are sometimes referred to as finger "blow-out". Accordingly, FIG. 3 illustrates one problem associated with prior art stern fingers, e.g., finger 200.

5 FIG. 4 shows two profiles, FIG. 4A and FIG. 4B, that show a prior art ACV skirt system 400 with a finger and planing element or stiffener 414. Planing elements or stiffeners, such as 414, have been used to prevent scooping and related problems, described above, for closed stern fingers or stern finger cones in certain applications. Planing element 414 is attached to a leading edge 404a of the closed finger 404. FIG. 4A shows the direction of ACV
10 movement 1 relative to the underlying water or terrain 416 for forward motion of the ACV. FIG. 4B shows the ACV moving in a reversed direction relative to FIG. 4A, with the ACV movement 3 and underlying terrain, e.g., water, movement 4 indicated.

Stiffeners such as 414 may reduce the occurrence of scooping, however they may introduce
15 other disadvantages for the associated skirt systems. Stiffeners are typically made from multiple bonded layers of skirt fabric or hard plastic. As a result of such construction, cones or fingers with stiffeners may be two to three (or more) times heavier than conventional open-finger designs. Additionally, fingers with stiffeners such as 414 may be more expensive than open-finger designs.

20 With particular reference to FIG. 4B, another notable problem associated with the use of stiffeners 414 may be seen. When an ACV having stern fingers 404 with leading edge stiffeners 414a backs up or moves to the stern, the stiffener tip 414a can snag on the underlying terrain or water surface 416 as shown. Such snagging of the stiffener tip 414a
25 may increase the moving resistance of the ACV and possibly result in damage to the finger 404 and adjacent structure of the skirt system 400. For example, flagellating remnants of a damaged or blown-out finger with stiffeners may cause damage to adjacent fingers or other portions of the associated skirt system.

30 FIG. 5 shows the underside of a stern corner of prior art ACV skirt system 500 having fingers with stiffening elements. The direction of water surface flow 1 is shown and represents the direction of water flow for normal forward motion of the related ACV. The skirt system 500 has a skirt bag (omitted for clarity) with attached fingers including stern fingers 504 and stern

corner fingers 506. The fingers 504, 506 include stiffening elements 504a, 506a located at the leading edges.

5 When stiffeners 506a are used with stern corner fingers 506, the stiffening elements 506a may twist and under go a displacement 506b, e.g., either up or down, due to the water surface flow 1 relative to the ACV. The twisting of the stiffeners 506a produces drag on the ACV and stress on adjacent fingers, e.g. stern corner fingers 506. Damage may occur to one or more of the adjacent fingers 506 as a result of such twisting and displacement 506b.

10 Attempts have been made to reinforce stern corner fingers to withstand twisting stresses produced by the forces on stiffener elements. However, these efforts have had only marginal success at increasing finger life and have significantly increased the cost and weight of the fingers.

15 What are needed therefore are lightweight, inexpensive stern fingers for an air-cushion vehicle (ACV) that are resistant to scooping and snagging. What are further needed are related methods of manufacturing such stern fingers for use with ACV skirt systems.

SUMMARY

20 Embodiments of the present invention are directed to wrapped-cone fingers that are lightweight, inexpensive and resistant to scooping and snagging. Wrapped-cone fingers may include an inner cone that is "wrapped" or generally enclosed by an outer finger. Embodiments of the present invention are also directed to skirt systems and methods of
25 manufacture wrapped-cone fingers for use with ACV skirt systems.

A first embodiment may include a wrapped-cone finger for an air-cushion vehicle (ACV) system. The wrapped-cone finger may include an outer finger having an outer finger surface having an outer finger opening. The outer finger may have an outer finger longitudinal axis.
30 The wrapped-cone finger may include an inner cone placed in the outer finger. The inner cone may have an inner cone longitudinal axis. The wrapped-cone finger is operable to move from an inflated state where the outer finger opening is substantially blocked by the inner cone to a deflated state where the outer finger opening is not substantially blocked by the inner cone.

The inner cone may include an inner cone opening. The outer finger may include an outer finger attachment perimeter for connection to a skirt bag surface. The inner cone may include an inner cone attachment perimeter for connection to a skirt bag surface. The outer
5 finger may be attached to a skirt bag surface. The outer finger may include a flexible material. The outer finger flexible material may be made of a suitable material such as nylon and may include an elastomer, such as for non-limiting example, natural rubber or rubber-coated fabric.

10 A second embodiment may include an air-cushion vehicle (ACV) skirt system that includes a skirt bag and a plurality of fingers attached to and depending from the skirt bag. The plurality of fingers includes one or more wrapped-cone fingers having an inner cone placed within an outer finger. Each of said one or more wrapped-cone fingers may include an outer
15 finger having an outer finger surface having an outer finger opening. The outer finger may have an outer finger longitudinal axis. Each of the one or more wrapped-cone fingers may include an inner cone placed in the outer finger. Each wrapped-cone finger is operable to move from an inflated state where the outer finger opening is substantially blocked by the inner cone to a deflated state where the outer finger opening is not substantially blocked by the inner cone.

20 The inner cone of a wrapped-cone finger may include an inner cone opening. The outer finger may include an outer finger attachment perimeter for connection to a surface of a skirt bag. The inner cone may include an inner cone attachment perimeter for connection to a surface of a skirt bag. The outer finger may include a surface of the skirt bag. The outer
25 finger may include a flexible material. The one or more wrapped-cone fingers may be located at a stern portion of the skirt bag. The one or more wrapped-cone fingers may be located at a stern corner portion of the skirt bag.

A third embodiment may include a method of manufacturing a wrapped-cone finger. An
30 outer finger may be formed of flexible material. An inner cone may be formed of flexible material. The inner cone may be placed in the outer finger, thereby forming a wrapped-cone finger. The outer finger may be attached to a skirt bag. The step of attaching the outer finger to a skirt bag may include a step of releasably attaching the outer finger to the skirt bag. The

step of attaching the outer finger to a skirt bag may include bolting or riveting the outer finger to the skirt bag. The inner cone may be attached to a skirt bag.

DESCRIPTION OF THE DRAWINGS

5

These and other features, aspects, and advantages of the present invention will become better understood with regard to the following description, appended claims, and accompanying drawings. The drawings are not necessarily to scale, emphasis instead being placed on illustration of principles of the invention. The drawings include the following figures:

10

FIG. 1 shows a perspective view of the underside of a representative hovercraft with prior art air-cushion vehicle (ACV) skirt system.

FIG. 2 shows a profile of a prior art skirt system.

15

FIG. 3 shows a profile of the skirt system of FIG. 2 with a conventional, prior art finger that is in a collapsed position

20

FIG. 4 shows two profiles, FIG. 4A and FIG. 4B, that show a prior art ACV skirt system with a finger and planing element or stiffener.

FIG. 5 shows the underside of a stern corner of prior art ACV skirt system having fingers with stiffening elements.

25

FIG. 6 shows a profile of one embodiment of the present invention including a wrapped-cone air cell or finger.

FIG. 7 is a perspective view of a stern portion of a skirt system with wrapped-cone fingers according to one embodiment

30

FIG. 8 shows a profile of the wrapped-cone finger of FIG. 6 with bow direction indicated.

FIG. 9 shows the underside of a skirt system according to one embodiment.

FIG. 10 shows steps in a method of manufacturing a wrapped-cone finger for use in a skirt system.

DETAILED DESCRIPTION

5

The present invention may be understood by the following detailed description, which should be read in conjunction with the attached drawings. The following detailed description of certain embodiments is by way of example only and is not meant to limit the scope of the present invention.

10

Embodiments of the present invention are directed to wrapped-cone fingers for use in an air-cushion vehicle (ACV) skirt system. Wrapped-cone fingers according to the present invention may be lightweight, inexpensive and resistant to scooping and snagging. Wrapped-cone fingers may include an inner cone that is “wrapped” or generally enclosed by an outer
15 finger. Embodiments of the present invention are also directed to skirt systems and methods of manufacturing wrapped-cone fingers.

FIG. 6 shows a profile of one embodiment 600 of the present invention including a wrapped-cone air cell or finger 604. The wrapped-cone finger 604 may include an outer finger 606 of flexible material that “wraps” or generally encloses an inner cone 608 of flexible material. The outer finger 606 may be attached to a skirt bag 602 as part of an air-cushion vehicle (ACV) skirt system. In certain embodiments, the outer finger may be attached to an intermediate attachment structure or finger flap (not shown) that is attached to the skirt bag 602. The outer finger 606 may include a leading face or edge 606a and an opening or open
25 back face 606b. The inner cone may have a lower opening 608a. The wrapped-cone finger 604 may be located at the stern or stern corners of a skirt bag in certain embodiments. The skirt bag 602 may be inflated by suitable means. For example, the skirt bag may be inflated with air from one or more air ducts 614 receiving air from fans located on a deck 610 of the ACV.

30

The outer finger 606 may have an outer finger longitudinal axis 606c substantially along the midline of the volume or interior defined by the outer finger 606 surface. The inner cone 608 may have an inner cone longitudinal axis 608b. When the wrapped-cone finger 604 is in an inflated state, the inner cone longitudinal axis 608b may be in a first position relative to the

outer finger longitudinal axis **606c**. In certain embodiments, the first position of the inner cone longitudinal axis may be substantially perpendicular or not parallel to the outer finger longitudinal axis **606c**, for example as shown in FIG. 6. When the wrapped-cone finger **604** is in a deflated state, for example as shown in FIG. 8, the inner cone longitudinal axis **608b** may be in a second position with respect to the outer finger longitudinal axis **606c**. In certain embodiments, the second position of the inner cone longitudinal axis **608b** may be more acute or more closely parallel to the outer finger longitudinal axis **606c** when compared to the first position. It should be understood that the respective cones and fingers, including the respective longitudinal axes, may bend or deform as the respective cones and fingers move and/or deform in shape during usage.

Any suitable materials may be used for the skirt bag **602** and wrapped-cone finger **604**. For example, the skirt bag **602** and wrapped-cone finger **604** may be made from materials including but not limited to elastomer-coated fabrics. In certain embodiments, a Type I Rubber Coated Fabric, Part No. 50000010, made by Bell Avon, Inc. of 1200 Martin Luther King Jr. Blvd, Picayune, Mississippi 39466 may be used. Suitable coatings may include but are not limited to polybutadiene or natural rubber. In certain other embodiments, neoprene or natural rubber coated nylon may be used for a wrapped-cone finger **604**. The thickness of any coating and amount of plies and density of the base, e.g., nylon fabric, may be adapted to a particular application. For example, the thickness of the base and the number of base plies may be selected based on design parameters such as finger size, ACV speed, cushion pressure, and weight of the ACV.

With continued reference to FIG. 6, the inner cone **608** may receive air through an inner cone feed hole **612a** located in the wall of the skirt bag **602**. During the inflation, the inner cone lower opening **608a** may be sealed or substantially sealed by the leading face **606a** of the outer finger **606**. As the inner cone **608** becomes inflated, it obstructs or blocks the passage of air out of the open back face **606b** of the outer finger, creating a pressure differential between the interior of the outer finger **606** and the ambient environment. In certain embodiments, the outer finger **606** may receive air through one or more outer finger feed holes **612b**. A feed duct **614** is shown in the hull **610** for the inflation of the skirt bag **602**.

FIG. 7 is a perspective view of a stern portion of a skirt system **700** with wrapped-cone fingers according to one embodiment. The skirt system **700** may include a skirt bag **702** and

one or more wrapped-cone fingers **704**. The wrapped-cone fingers **704** may each include an outer finger **706** and an inner cone **708**. An outer finger **706** may include a leading edge or face **706a** and an open back face **706b**. Each inner cone **708** may be located within the interior of an outer finger **706**. When inflated as shown, each inner cone **708** may block the
5 open back face **706b** of the associated outer finger **706**.

Referring to FIG. 8, use of an embodiment of the present invention will now be described. FIG. 8 shows a profile of the wrapped-cone finger **604** of FIG. 6 with bow direction **1** indicated. The wrapped-cone finger **604** is shown in a collapsed state due to the impact of a
10 wave **8**. During the operation of an associated ACV over a water surface, the force of the impacting wave **8** may cause wrapped-cone finger to deflate, e.g., by causing air to exit through the inner cone opening **608a** and the open back face **606b**.

When a wave **8** hits or impacts the leading edge **606a** of the wrapped-cone finger **604**, the
15 outer finger or cone **606** sweeps back and the inner cone **608** collapses. After the wave **8** passes, the inner cone **608** reinflates with air forced through the one or more inner cone feed holes **612a**, thereby closing the back of the outer finger **606b** and allowing the outer the wrapped-cone finger **604** to reinflate. The inflation of the wrapped-cone finger **604** with air from the skirt bag **602** and feed duct **614** may be further facilitated by an optional outer finger
20 feed hole **612b**. The outer finger feed hole **612b** may open into the outer finger **606** at a location interior to the inner cone **608**.

Because the wrapped-cone finger **604** does not have an attached back-face, forces on the leading edge **606a** due to impacting waves tend to collapse the outer finger **606** and angle or
25 sweep the inner cone **608** backward within the wrapped-cone finger **604**. As the inner cone **608** sweeps backward, air is pushed out of the wrapped-cone finger **604** through the inner cone lower opening **608a** and the open back face **606b** of the outer finger **606**. When the wrapped-cone finger **604** is deflated by an impacting wave in this manner, scooping may be minimized or avoided altogether. The lack of any stiffeners minimizes or prevents snagging
30 and allows the wrapped-cone finger **604** to be light-weight.

FIG. 9 shows the underside of a skirt system **900** according to one embodiment. The skirt system **900** may include wrapped-cone fingers **904** at the stern and stern corner areas of an associated skirt bag **902** and open fingers **906** at the skirt port and starboard sides. Water

surface flow direction **1** is indicated for movement of the related ACV and skirt system **900** toward or in front of the ACV bow.

The wrapped-cone fingers **904** may be installed or located in stern corner areas of an
5 associated skirt bag without the inherent problems of stiffener elements, e.g., **506a** of FIG. 5, misaligned to the ACV direction. Compared to fingers having stiffener elements, e.g., fingers **506** with stiffeners **506a** shown in FIG. 5, an outer edge **904a** of a wrapped-cone finger **904** may have a more rounded interface with the water surface flow **1**. Consequently, the wrapped-cone fingers **904** are resistant to twisting and displacement when water flows across
10 the finger **904**. Problems described above regarding prior art skirt systems and fingers, e.g., twisting and drag, may be consequently be minimized or eliminated.

FIG. 10 shows steps in a method **1000** of manufacturing a wrapped-cone finger for use in a skirt system. An outer finger of flexible fabric may be formed **1002**. An inner cone of
15 flexible fabric may be formed **1004**. The inner cone may have an inner cone lower opening. The outer finger may have an open back face. The inner cone may be attached **1006** to a skirt bag for use on an air cushioned vehicle (ACV). The outer finger may be attached **1008** to the skirt bag around the inner cone, thereby forming a wrapped cone finger. The outer finger may optionally be attached **1010** to a finger flap acting as an intermediate attachment
20 structure between the skirt bag and the outer finger. An adjacent finger for use in a skirt system of an ACV may be attached **1012** to the finger flap. The adjacent finger may include a wrapped-cone finger.

Accordingly, embodiments of the present invention may provide wrapped-cone fingers and
25 skirt systems that have advantages over the prior art. In certain embodiments, wrapped-cones fingers may be lower in cost and lighter in weight than typical fingers. Wrapped-cone fingers may be located at desired portions or locations of a skirt bag for an air cushioned vehicle (ACV) including, for non-limiting example, the stern and stern corner portions of a skirt bag. Embodiments may eliminate the need for stiffeners or planing elements for certain types of
30 fingers, e.g., stern fingers and stern corner fingers. Wrapped-cone fingers may also be installed in corners portions or areas of a skirt bag without the inherent problems of stiffener elements being misaligned to the craft direction. In certain embodiments, stern fingers may be created that have low-drag, stable shapes that minimize or prevent the scooping of water.

5 Wrapped-cone fingers of certain embodiments may be suitable for implementation or retrofit on existing air-cushion vehicles (ACVs) and associated skirt systems. For example, wrapped-cone fingers according to the present invention may be suitable for implementation on ACVs including, but not limited to, the Landing Craft, Air Cushion (LCAC) used by the U.S. Navy.

10 Failure modes for certain embodiments may be a gradual wearing out of the outer finger or cone material, and then wearing out the bottom of the inner cone due to abrasion and flagellation. In the case that failure of an individual wrapped-cone finger occurs, undue damage to adjacent fingers or skirt bag areas may be minimized or prevented. Embodiments may also provide improved longevity for skirt systems and ease of repair may be increased by localized spot repair, e.g., the application of patches, to portions of the wrapped-cone outer and inner assemblies.

15 Although the present invention has been described in considerable detail with reference to certain preferred version thereof, other versions are possible. For example, while the previous description has described use of wrapped-cone fingers at stern and stern corner locations of ACV skirt systems, wrapped-cone fingers may be used at other locations of skirt systems in certain embodiments.

20 The reader's attention is directed to all papers and documents that are filed concurrently with this specification and which are open to public inspection with this specification, and the contents of all such papers and documents are incorporated herein by reference. All the features disclosed in this specification, including any accompanying claims, abstract, and drawings, may be replaced by alternative features serving the same, equivalent or similar purpose, unless expressly stated otherwise.

25

30

CLAIMS

What is claimed is:

1. A wrapped-cone finger for an air-cushion vehicle skirt system, said wrapped-cone finger
5 comprising:
 an outer finger having an outer finger surface having an outer finger opening; and
 an inner cone disposed within said outer finger;
wherein said wrapped-cone finger is operable to move from an inflated state where said outer
finger opening is substantially blocked by said inner cone to a deflated state where said outer
10 finger opening is not substantially blocked by said inner cone.
2. The wrapped-cone finger of Claim 1, wherein said inner cone further comprises an inner
cone opening.
- 15 3. The wrapped-cone finger of Claim 1, wherein said first outer finger surface further
comprises an outer finger attachment perimeter for connection to a skirt bag surface.
4. The wrapped-cone finger of Claim 1, wherein said inner cone further comprises an inner
cone attachment perimeter for connection to a skirt bag surface.
20
5. The wrapped-cone finger of Claim 3, wherein said outer finger further comprises a skirt
bag surface attached to said attachment perimeter.
6. The wrapped-cone finger of Claim 1, wherein said outer finger comprises a flexible
25 material.
7. The wrapped-cone finger of Claim 6, wherein said flexible material comprises an
elastomer.
- 30 8. The wrapped-cone finger of Claim 6, wherein said flexible material comprises natural
rubber.
9. The wrapped-cone finger of Claim 6, wherein said flexible material comprises a rubber-
coated fabric.

10. The wrapped-cone finger of Claim 9, wherein said rubber-coated fabric includes polybutadiene as a coating.
- 5 11. The wrapped-cone-finger of Claim 6, wherein said flexible material includes a nylon base fabric.
12. The wrapped-cone finger of Claim 11, wherein said nylon base fabric includes one or more plies of nylon fabric.
- 10 13. The wrapped-cone finger of Claim 1, wherein said outer finger includes an outer finger longitudinal axis and said inner cone includes an inner cone longitudinal axis, wherein in said inflated state said inner cone longitudinal axis is in a first position with respect to said outer finger longitudinal axis, and wherein in said deflated state said inner cone longitudinal axis is
- 15 in a second position with respect to said outer finger longitudinal axis.
14. The wrapped-cone finger of Claim 13, wherein said first position of said inner cone longitudinal axis is substantially perpendicular to said outer finger longitudinal axis.
- 20 15. The wrapped-cone finger of Claim 13, wherein said second position of said inner cone longitudinal axis is substantially parallel to said outer finger longitudinal axis.
16. An air cushion vehicle (ACV) skirt system comprising:
- 25 a skirt bag;
- a plurality of fingers attached to and depending from said skirt bag, wherein said plurality of fingers includes one or more wrapped-cone fingers having an inner cone placed within an outer finger.
17. The system of Claim 16, wherein each of said one or more wrapped-cone fingers
- 30 comprises:
- an outer finger having an outer finger surface defining an outer finger opening and an outer finger interior having an outer finger longitudinal axis; and

an inner cone disposed with said outer finger interior, said inner cone having an inner cone longitudinal axis that is not parallel to said outer finger longitudinal axis when said inner cone is in an inflated state.

5 18. The system of Claim 17, wherein said inner cone further comprises an inner cone opening.

19. The system of Claim 17, wherein said outer finger further comprises an outer finger attachment perimeter for connection to a surface of said skirt bag.

10

20. The system of Claim 17, wherein said inner cone further comprises an inner cone attachment perimeter for connection to a surface of said skirt bag.

15 21. The system of Claim 19, wherein said outer finger attachment perimeter comprises a finger flap.

22. The system of Claim 17, wherein said first outer finger comprises a flexible material.

20 23. The system of Claim 17, wherein said one or more wrapped-cone fingers are located at a stern portion of said skirt bag.

24. The system of Claim 17, wherein said one or more wrapped-cone fingers are located at a stern corner portion of said skirt bag.

25 25. A method of manufacturing a wrapped-cone finger comprising the steps of:
forming an outer finger of flexible material having an outer finger opening;
forming an inner cone of flexible material having an inner cone opening;
attaching said inner cone to a skirt bag; and
attaching said outer finger to a skirt bag around a location of said inner cone, thereby
30 forming a wrapped-cone finger operable to move from an inflated state where said outer finger opening is substantially blocked by said inner cone to a deflated state where said outer finger opening is not substantially blocked by said inner cone.

26. The method of Claim 25, wherein said step of attaching said inner cone to a skirt bag is performed before said step of attaching said outer finger to a skirt bag.
27. The method of Claim 25, wherein said step of attaching said outer finger to a skirt bag
5 includes the step of releasably attaching said outer finger to said skirt bag.
28. The method of Claim 25, wherein said step of attaching said outer finger to a skirt bag includes the step of attaching said outer finger to a finger flap.
- 10 29. The method of Claim 28, wherein said step of attaching said outer finger to a skirt bag includes the step of riveting said outer finger to said finger flap.
30. The method of Claim 25, wherein said step of attaching said inner cone to a skirt bag includes attaching said inner cone to a finger flap.
15
31. The method of Claim 25, wherein said step of attaching said inner cone to a skirt bag includes the step of releasably attaching said inner cone to said skirt bag.
32. The method of Claim 31, wherein said step of attaching said inner cone to a skirt bag
20 includes the step of bolting said inner cone to said skirt bag.
33. The method of Claim 25, wherein said step of attaching said inner cone to a skirt bag includes the step of riveting said inner cone to said skirt bag.
- 25 34. The method of Claim 28, further comprising a step of attaching an adjacent finger to said finger flap.
35. The method of Claim 34, wherein said adjacent finger is a wrapped-cone finger.
- 30 36. The method of Claim 34, wherein said step of attaching said adjacent finger to said finger flap includes a step of releasably attaching said adjacent finger to said finger flap.
37. The method of Claim 34, wherein said step of attaching said adjacent finger to said finger flap includes a step of bolting said adjacent finger to said finger flap.

38. The method of Claim 34, wherein said step of attaching said adjacent finger to said finger flap includes a step of riveting said adjacent finger to said finger flap.

5 39. The method of Claim 25, wherein said step of attaching said outer finger to a skirt bag comprises attaching said outer finger to a stern portion of a skirt bag.

40. The method of Claim 39, wherein said step of attaching said outer finger to a stern portion of a skirt bag comprises attaching said outer finger to a stern corner portion of a skirt
10 bag.

41. The method of Claim 25, wherein said step of attaching said outer finger to a skirt bag comprises retrofitting said outer finger to a pre-existing skirt bag on an air cushion vehicle (ACV).

15

42. The method of Claim 41, wherein said step of attaching said inner cone to a skirt bag comprises retrofitting said inner cone to a pre-existing skirt bag on an air cushion vehicle (ACV), thereby retrofitting said skirt system with a wrapped-cone finger.

20

25

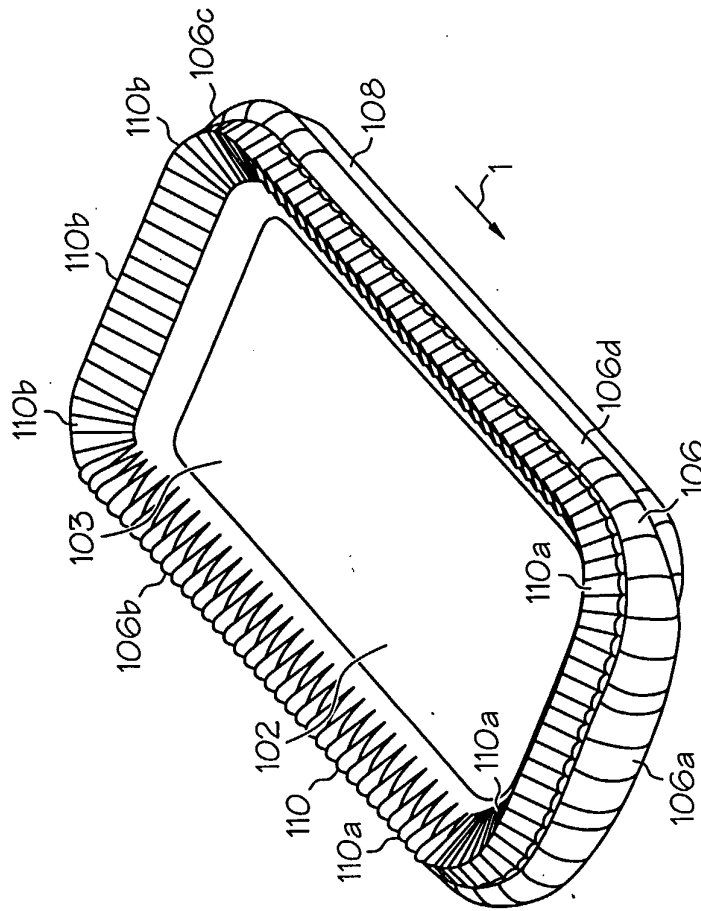

100
FIG. 1
(PRIOR ART)

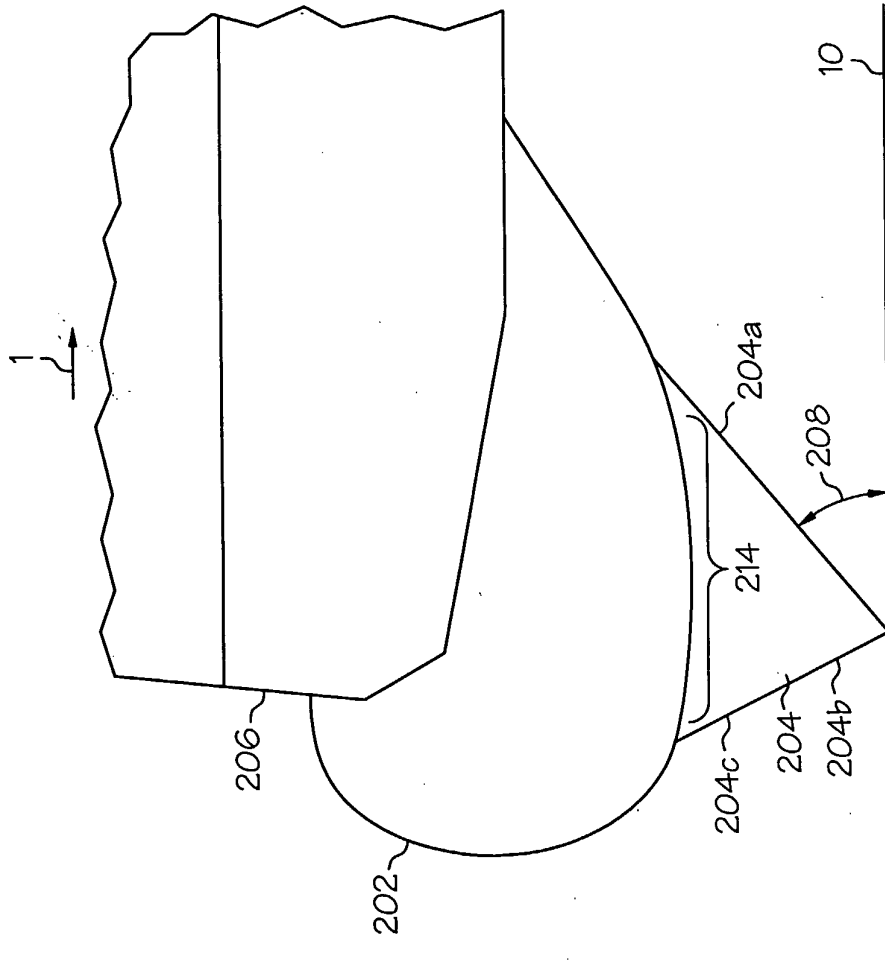

200
FIG. 2
(PRIOR ART)

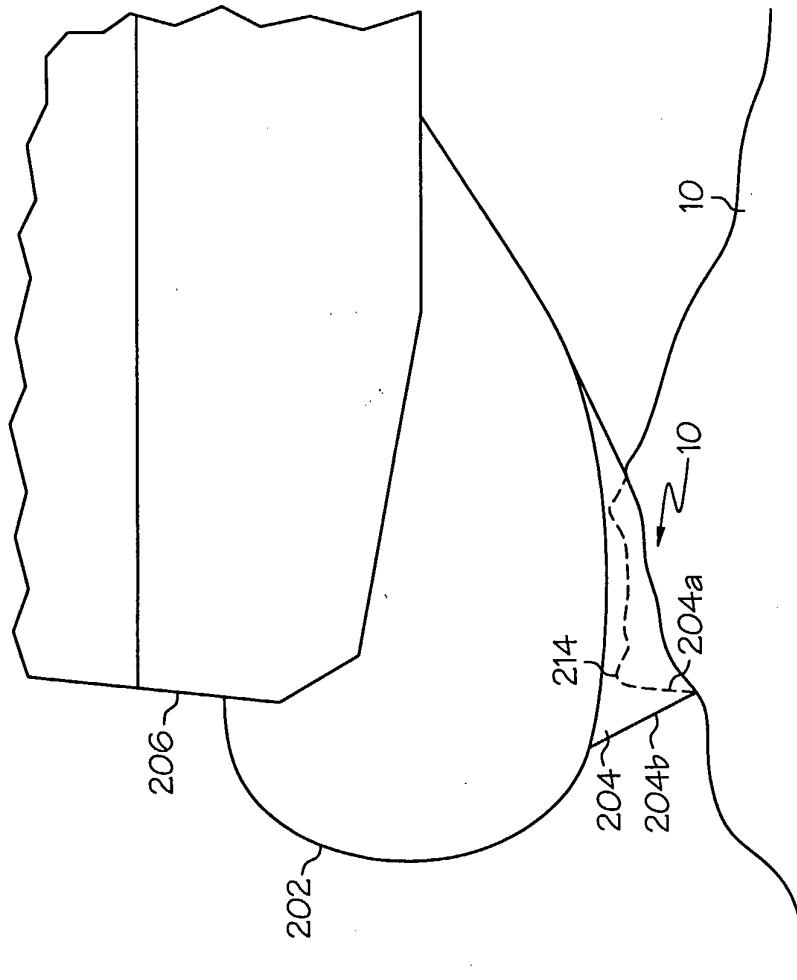

FIG. 3
(PRIOR ART)

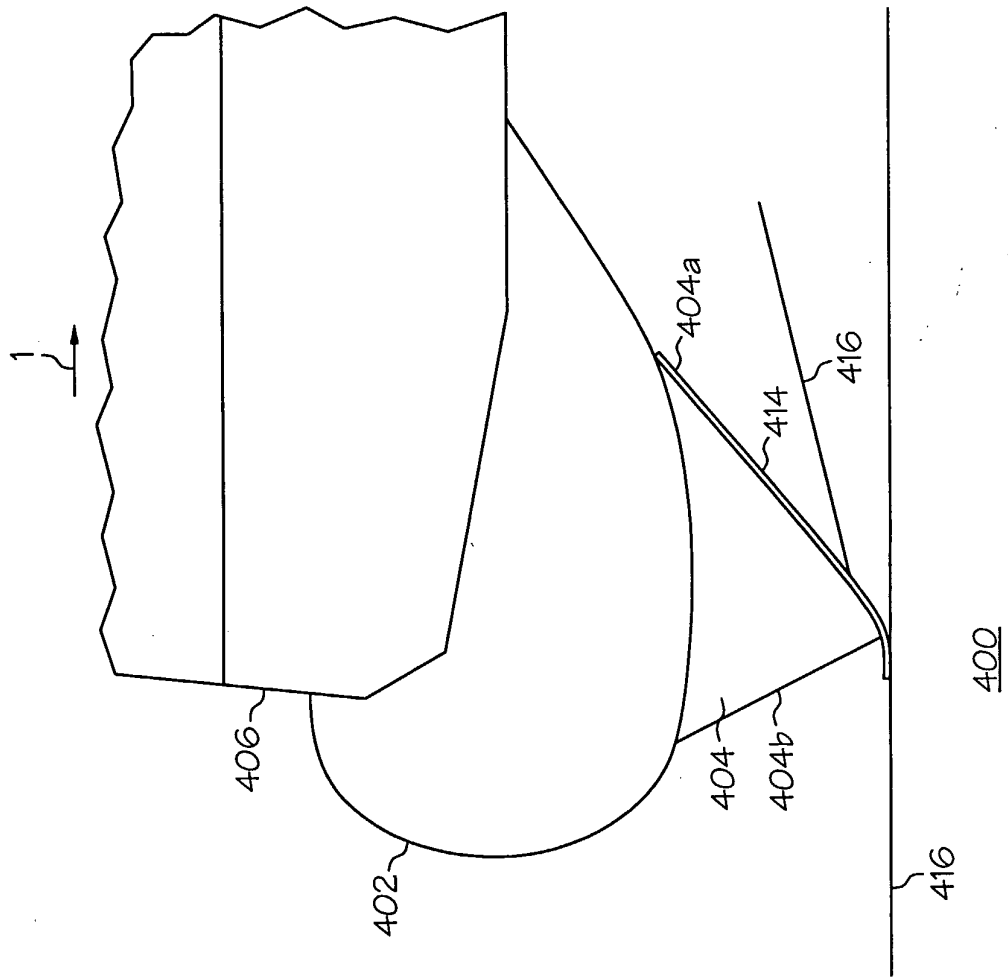

FIG. 4A
(PRIOR ART)

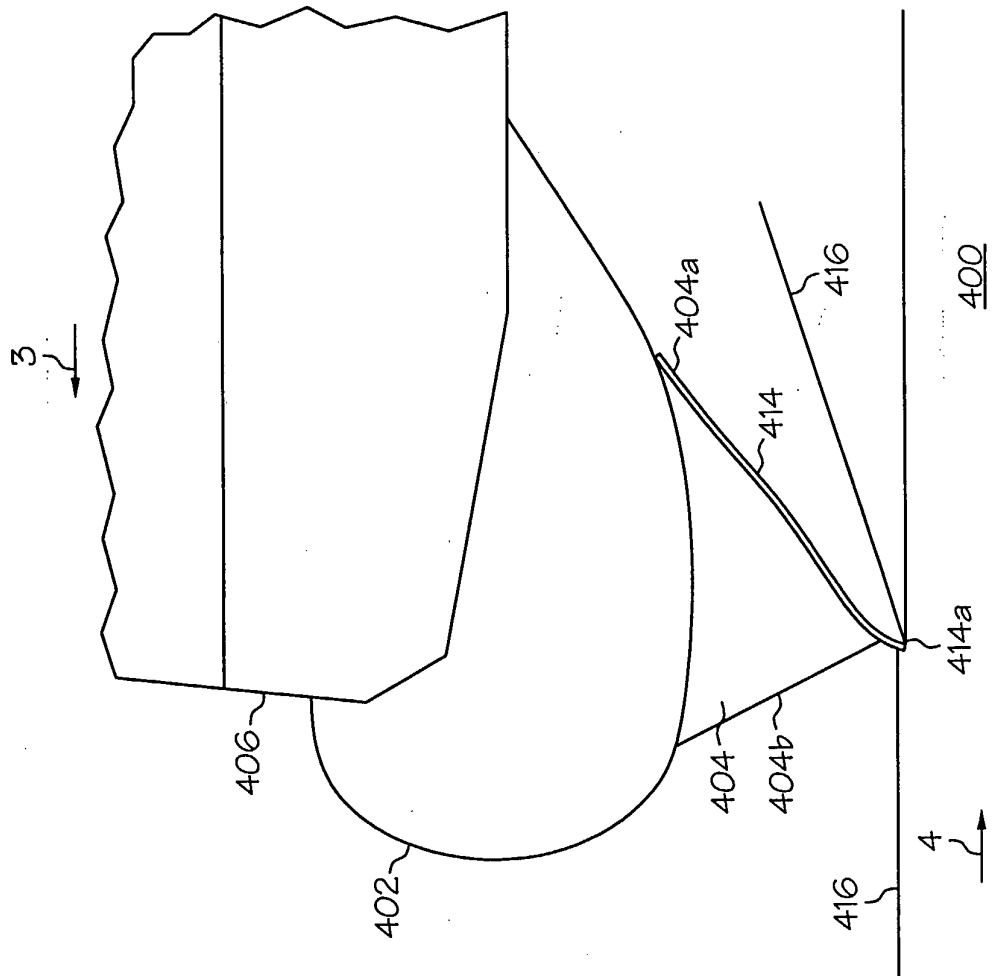

FIG. 4B
(PRIOR ART)

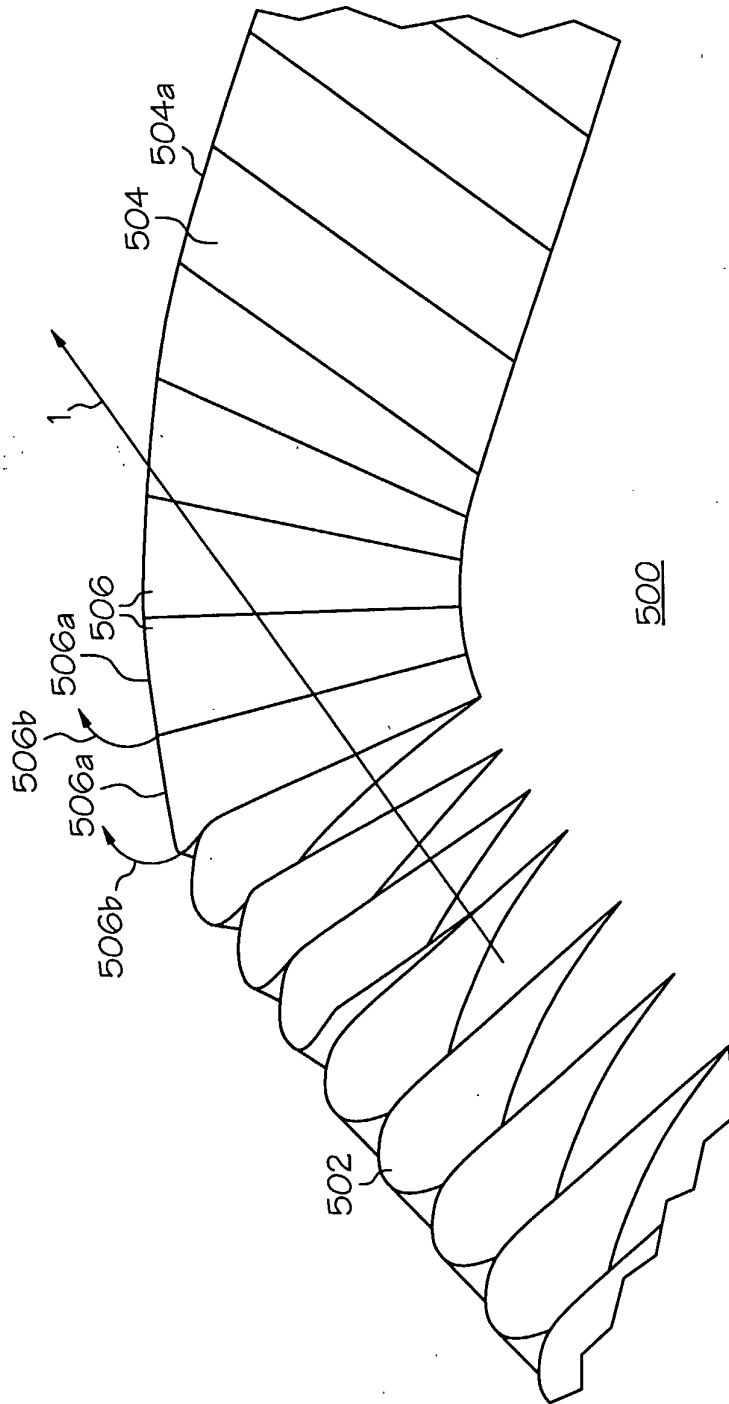

FIG. 5
(PRIOR ART)

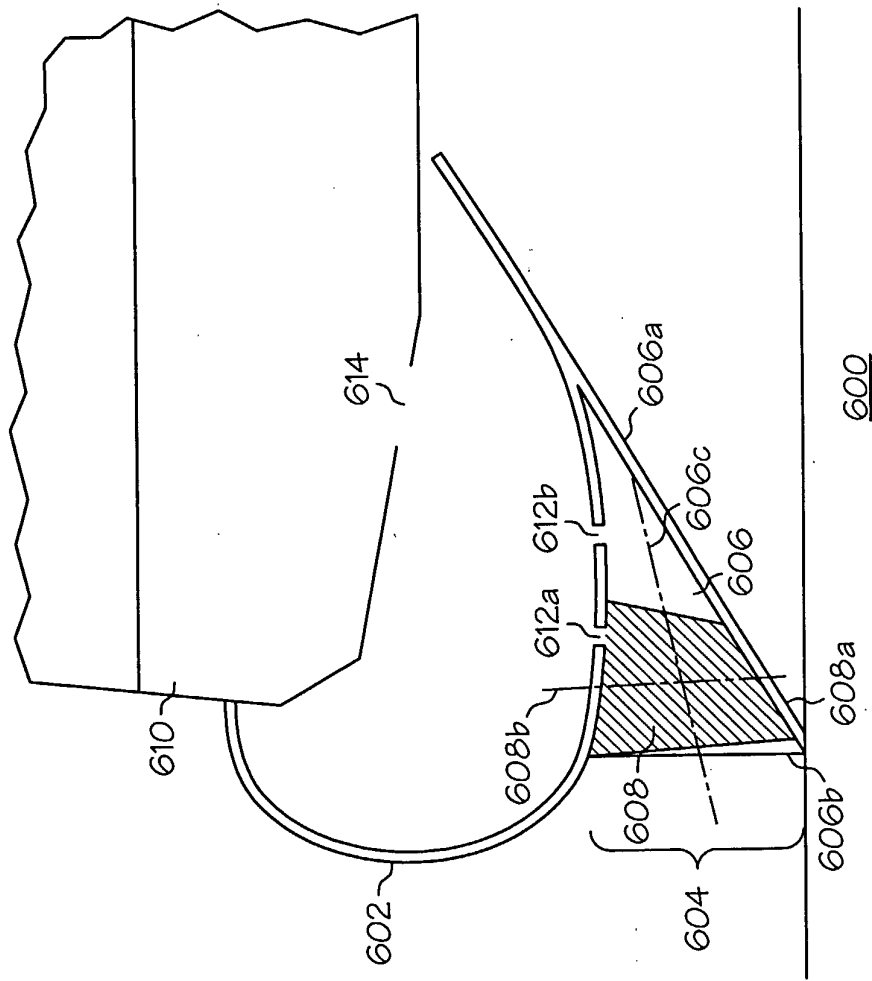
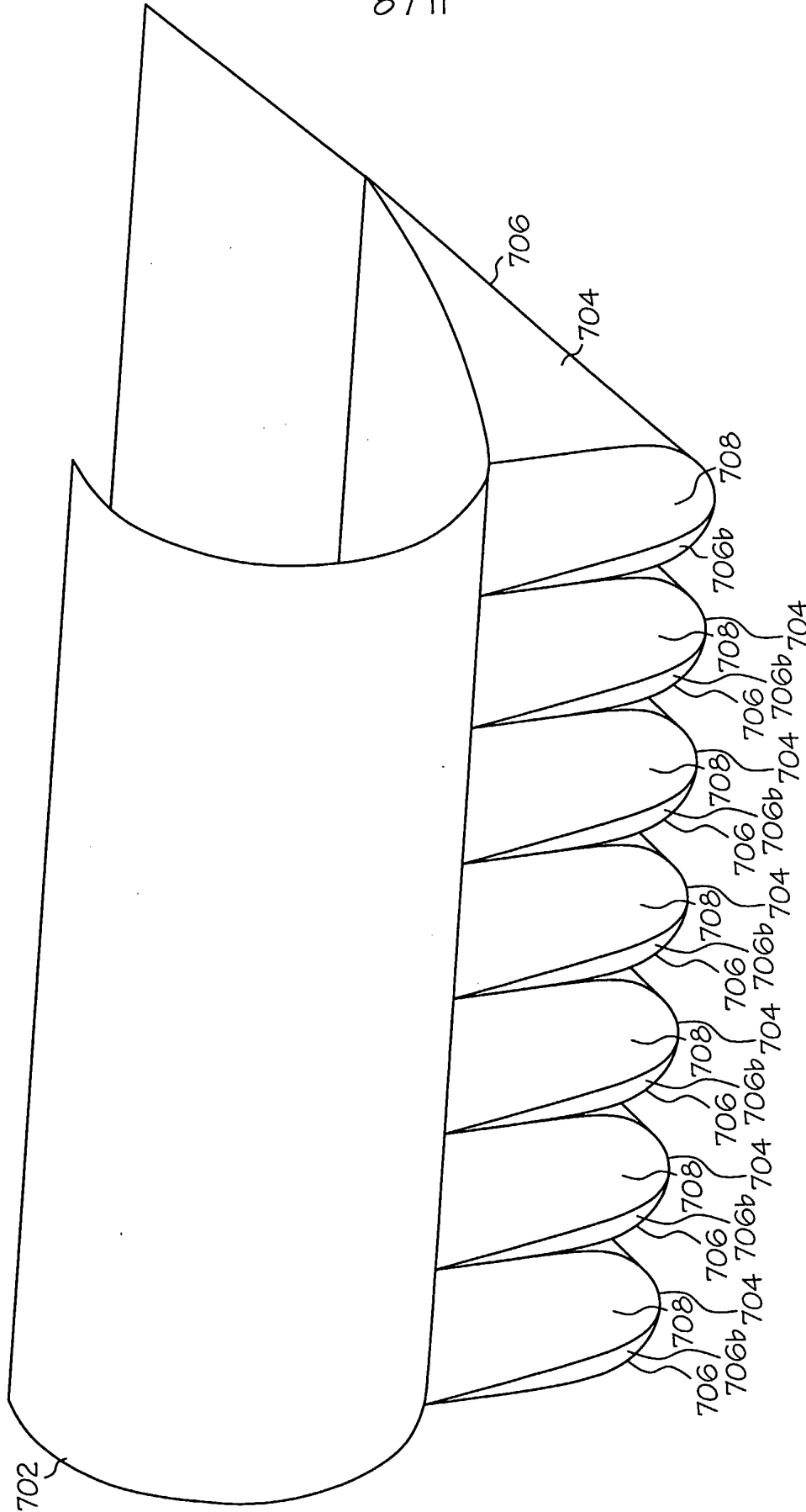

FIG. 6



700

FIG. 7

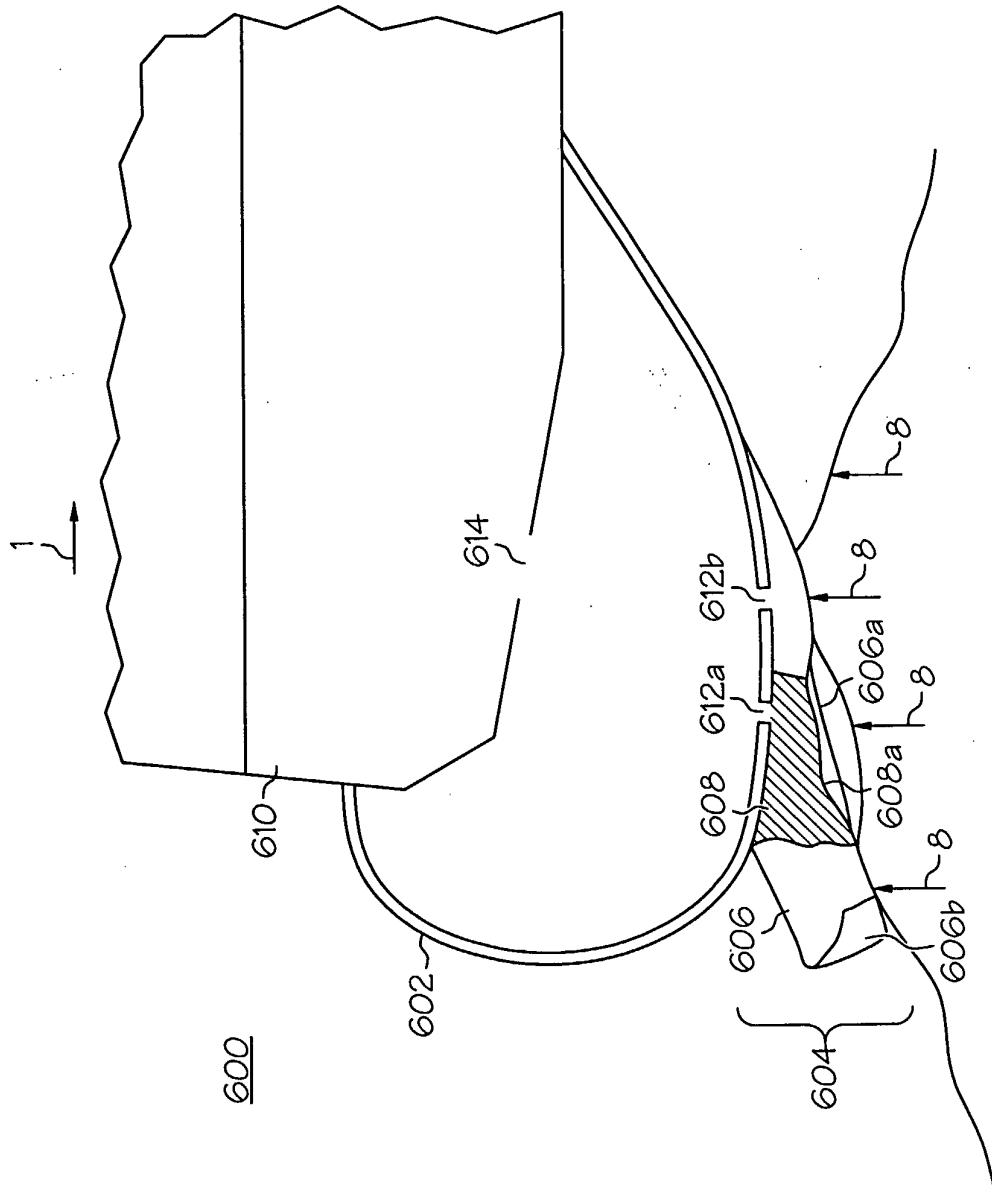

FIG. 8

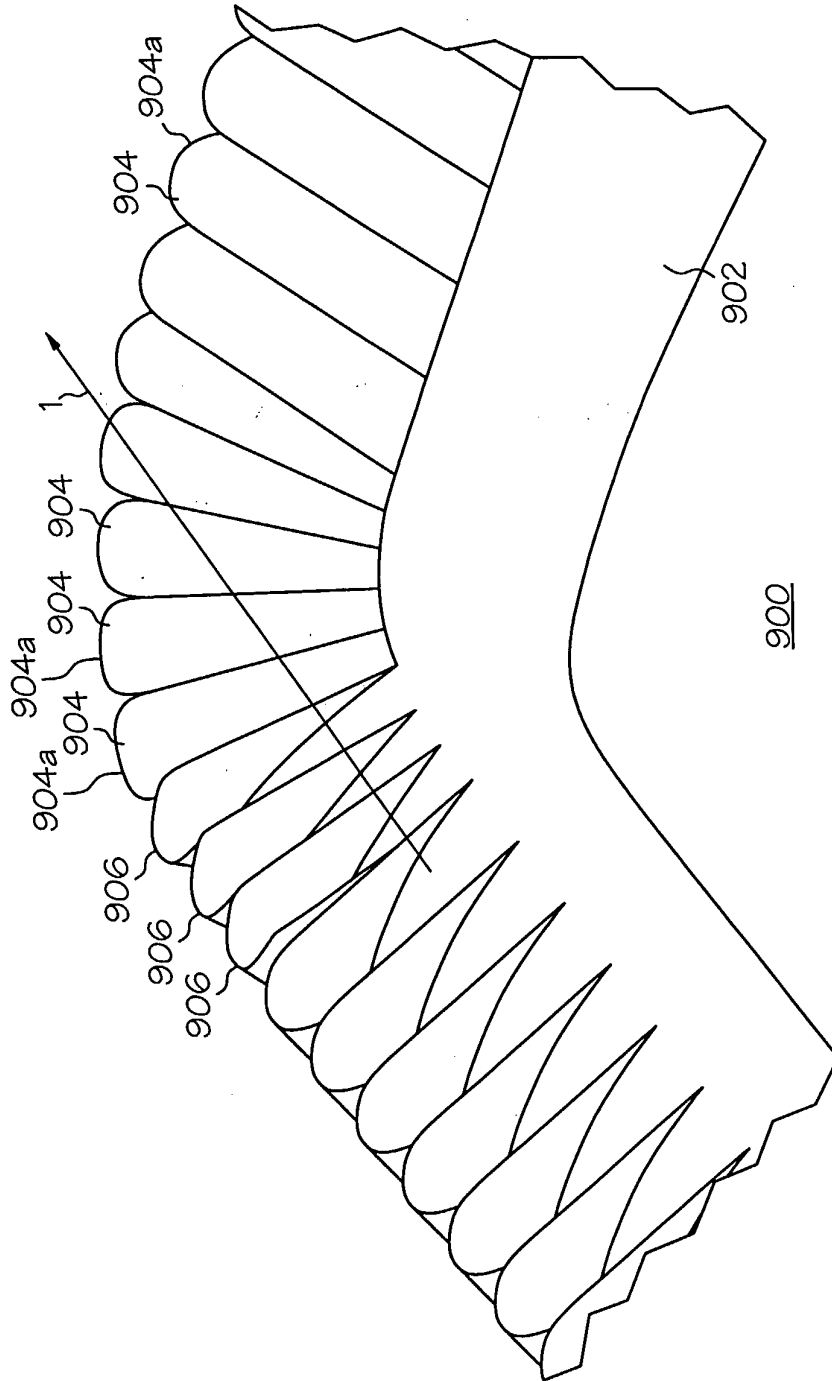
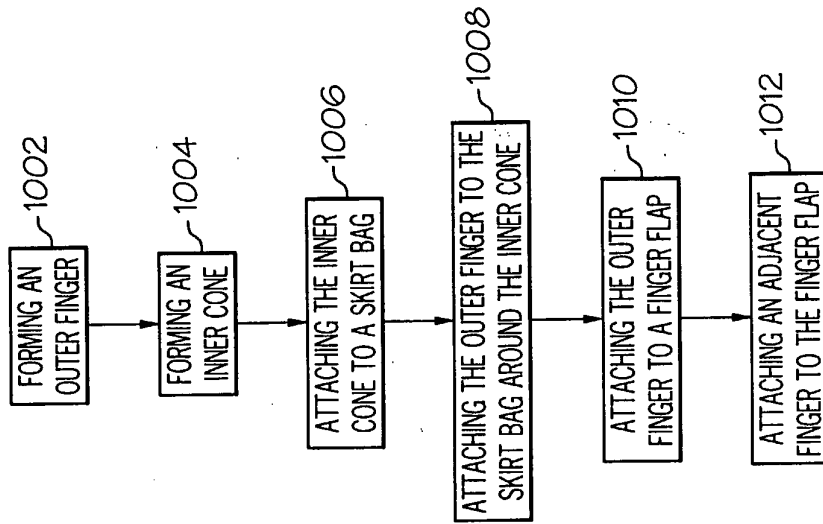

FIG. 9



1000

FIG. 10