



Europäisches Patentamt  
European Patent Office  
Office européen des brevets



Publication number: **0 404 189 B1**

**EUROPEAN PATENT SPECIFICATION**

- (49) Date of publication of patent specification: **30.11.94** (51) Int. Cl.<sup>5</sup>: **D21F 11/04, D21H 27/38**  
(21) Application number: **90111901.6**  
(22) Date of filing: **22.06.90**

(54) **A method of making a two-ply tissue and a two-ply tissue product.**

(30) Priority: **23.06.89 US 370427**

(43) Date of publication of application:  
**27.12.90 Bulletin 90/52**

(45) Publication of the grant of the patent:  
**30.11.94 Bulletin 94/48**

(84) Designated Contracting States:  
**AT BE CH DE DK ES FR GB GR IT LI LU NL SE**

(56) References cited:  
**EP-A- 0 003 377**  
**US-A- 4 300 981**

(73) Proprietor: **KIMBERLY-CLARK CORPORATION**  
**401 North Lake Street**  
**Neenah, Wisconsin 54956-0349 (US)**

(72) Inventor: **Allen, Peter John**  
**3261 Brook Highland Trace**  
**Birmingham Alabama 35242 (US)**  
Inventor: **Bauernfeind, Robert Norman**  
**6 Freddy's Lane**  
**Brookfield Conn. 06804 (US)**

(74) Representative: **Diehl, Hermann O. Th., Dr. et al**  
**Diehl & Glaeser, Hiltl & Partner**  
**Patentanwälte**  
**Postfach 19 03 65**  
**D-80603 München (DE)**

**EP 0 404 189 B1**

Note: Within nine months from the publication of the mention of the grant of the European patent, any person may give notice to the European Patent Office of opposition to the European patent granted. Notice of opposition shall be filed in a written reasoned statement. It shall not be deemed to have been filed until the opposition fee has been paid (Art. 99(1) European patent convention).

## Description

The invention relates to a method of forming a two-ply tissue and a two-ply tissue product.

In the manufacture of tissue products such as facial and bathroom tissue, it is known to improve the softness of the tissue by incorporating hardwood fibers into the tissue furnish. This can be accomplished by using a blended furnish or by making a layered product in which the hardwood fibers are concentrated in the outer layers. An example of a layered tissue process and product is provided by U.S. Patent No. 4,300,981 to Carstens, in which a tissue web having 60% or more short fibers in the outer layer is disclosed. However, conventional wisdom in the tissue industry, as evidenced by Carstens, is that in order to obtain a softer, smoother tissue, it is preferred to use the dryer side of the tissue web as the outwardly facing surface of the final tissue product. This is because the dryer side of the tissue web (the side that is in contact with the dryer during drying and creping) experiences the greatest degree of debonding during creping and hence is traditionally viewed as the softer of the two sides of the tissue web. Hence commercially available layered prior art tissue is made by placing the hardwood layer against the dryer surface and positioning that layer as the outwardly facing surface of the final product. However, it has now been discovered that by producing a layered tissue web with a former commonly known in the industry as a crescent former, in which a tissue web is initially formed between a forming wire and a papermaking felt, a superior product can be made with a lesser amount of short fibers.

The invention provides a method of making a two-ply tissue product according to independent claim 1 and a two-ply facial tissue according to independent claim 8. Further features and advantages of the process and products are evident from the dependent claim; the following description and examples. The claims should be viewed as a first non-limiting approach of defining the invention in general terms.

In one aspect, the invention resides in a method for making a two-ply tissue product comprising:

- a. depositing a stratified aqueous slurry of papermaking fibers on a forming wire to form a layered embryonic web, said embryonic web having a first layer of fibers comprising a substantial amount of short fibers and a second layer of fibers, preferably of predominantly long fibers, which provides most of the strength of the resulting tissue web and which is in contacting relationship with the forming wire;
- b. dewatering the web, preferably to a consistency of about 30 weight percent or greater;

- c. adhering the dewatered web to the surface of a rotating drying cylinder and drying the web;
- d. creping the dried web to form a tissue web and

- 5 e. converting the tissue web into a two-ply tissue product wherein the first layer of the tissue web is positioned as an outwardly facing surface of the tissue product;

the improvement over the prior art being that

- 10 f. said stratified aqueous slurry of papermaking fibers is deposited between said forming wire and a felt to form said layered embryonic web;
- g. said first layer of fibers is in contacting relationship with said felt and
- 15 h. said second layer is in contacting relationship with said surface of the drying cylinder.

In another aspect, the invention resides in a two-ply tissue product made by the method described herein.

- 20 It has been found that the method of this invention offers a large number of advantages. First, the resulting product has surprising softness and is preferred by users relative to untreated commercially available tissues made in the conventional manner. In addition, forming the embryonic web with the second layer, which is preferably predominantly long fibers, in contact with the forming wire provides a filter and forming base for the short fibers of the first layer and results in higher fiber retention than forming with a substantial amount of short fibers against the forming wire. Also, applying a predominantly long fiber layer against the drying/creping cylinder reduces the amount of dust generated during creping, both in the tissue web and in the manufacturing environment. Further, by winding two of these plies together with the dryer (dustier) side inward to convert the plies into a two-ply tissue product, the dust level in the manufacturing and converting areas of the mill are further reduced. Furthermore, such a two-ply tissue product exhibits reduced lint in use because the dustier sides of each of the two tissue webs are plied together inwardly in the middle of the tissue product. This is a significant benefit to the user, for which lint is a common complaint when using tissues having a significant level of hardwood fibers.
- 25
- 30
- 35
- 40
- 45

For purposes herein, a tissue web is a web suitable for use as a facial or bath tissue and having a finished basis weight of from about 2.3 to about 6.8 kg per 267.6m<sup>2</sup> (about 5 to about 15 pounds per 2880 square feet) per ply. Creped tissue web densities can be from about 0.1 to about 0.3 grams per cubic centimeter. Strengths in the machine direction can be from about 100 to about 1000 grams per 2.54 cm (1 inch) of width, preferably from about 200 to about 350 grams per 2.54 cm (1 inch) of width. Tensile strengths in the

cross-machine direction can be from about 50 to about 500 grams per 2.54 cm (1 inch) of width, preferably from about 100 to about 250 grams per 2.54 cm (1 inch) of width. Such webs are preferably made from natural cellulosic fiber sources such as hardwoods, softwoods, and none species, but can also contain significant amounts of synthetic fibers.

Figure 1 is a schematic flow diagram of the method of this invention.

Figure 2 is a schematic flow diagram of the converting step of this invention, depicting plying of two creped webs together such that the layers containing a substantial amount of short fibers are the outwardly facing surfaces of the final tissue product.

Referring to Figure 1, the invention will be described in greater detail. Shown is a multi-layered headbox 1 which can have one, two, or more internal dividers for separating different furnishes during formation of an embryonic web. Headboxes of this kind are well known in the paper industry and a wide variety of suitable designs are available. Not shown is the stock system for supplying the multi-layered headbox with different furnishes used to form the different layers within the tissue. In operation, the headbox deposits a stratified aqueous slurry of papermaking fibers between a forming wire 2 and a felt 3. Each of the strata consists of a fibrous slurry of different characteristics. The felt is wrapped around the forming roll 4. The forming wire is also partially wrapped around the forming roll, but to a lesser extent, and simultaneously spans the gap between the breast roll 5 and the wire take-off roll 6. Remaining rolls 7, 8, 9, and 10 provide means to properly adjust the tension of the forming wire. The relative positions of the forming roll, the breast roll, and the wire take-off roll must be adjusted to optimize the forming process.

The forming wire is characterized by a weave which provides immediate water drainage while providing adequate support for the fibers deposited thereon. Typically these fabrics are made of polyester or nylon and have a mesh of at least about 80 and a count of at least about 100. On the other hand, the felt is characterized by a fabric construction which absorbs or wicks away water from the embryonic web to assist in dewatering and which causes the embryonic web to adhere to the felt. Typically felts are made of a woven base with graded layers of batt needled into the base, with finished weights of from at least about 102.1 gms per 0.09m<sup>2</sup> (about 3.6 ounces per square foot) to about 141.8 gms per 0.09m<sup>2</sup> (5 ounces per square foot).

The layered embryonic web contains at least two layers or strata. The first layer 15, which is in contacting relationship with the felt, comprises a

substantial amount of short fibers such as hardwood fibers. Suitably, the amount of short fibers constitutes at least 40 weight percent of the fiber content of the layer. Preferably, the amount of short fibers is from about 50 to about 60 weight percent of the layer, although amounts up to 100 percent can be used to further alter the surface characteristics of the web. Because of the presence of substantial amounts of short fibers which tend to form webs of low strength, the fiber composition of this first layer generally exhibits a handsheet TAPPI burst factor of about 15 meters<sup>2</sup> per gram<sup>2</sup>, second layer 16, which is in contacting relationship with the forming wire, can be of any composition which provides sufficient strength to the resulting tissue web for its intended use and preferably consists predominantly (50 dry weight percent or greater) of long fibers such as softwood fibers. For purposes herein, short fibers are those which have an average length of from about 0.25 millimeters to about 1.50 millimeters and primarily include hardwood fibers, such as eucalyptus fibers. Long fibers are those which have an average length greater than about 1.50 millimeters and primarily include softwood fibers. The strength layer fiber composition exhibits a greater handsheet TAPPI burst factor than the layer 15, which preferably is about 30 meters squared per gram squared.

In the vicinity between the forming roll 4 and the wire take-off roll 6, the forming wire is passively disengaged from the embryonic web, which remains with the felt. The embryonic web is dewatered by the absorbent action of the felt as the felt carries the web to the rotating drying cylinder 20. Transfer of the dewatered web to the drying cylinder takes place at the pressure roll 21, which presses the dewatered web against the surface of the drying cylinder. The degree of hardness of the pressure roll can vary, although pressure rolls having a hardness of about 38 P&J (as measured on the Pusey and Jones scale) are preferred. Adhesion of the dewatered web to the drying cylinder is accomplished by the presence of moisture in the web and is preferably augmented by the presence of a creping adhesive, which is applied by a suitable spray device 22 as shown. The creping adhesive can be any creping adhesive which provides the appropriate level of adhesion for the particular web composition and basis weight. Such adhesives are well known in the papermaking industry. Particular adhesives which have been found to work well are those based on polyvinyl alcohol. The web is then dried to about 5 weight percent moisture and is dislodged from the drying cylinder by contact with the doctor blade 23, which crepes the web. Because the second layer of the web (dryer side) is against the dryer surface, the formation of lint is minimized while the web is softened, particu-

larly if the second layer primarily contains long fibers. The creped web is then wound onto a soft roll 24 with the aid of a reel drum 25.

Figure 2 illustrates a method of combining two of the layered webs made as described above to form a two-ply facial tissue in accordance with this invention. Shown are two soft rolls 24 being unwound and brought together in a nip formed between a first pair of steel calender rolls 31 and 32 followed by a second pair of steel calender rolls 33 and 34. The calendered webs are then crimped together between an anvil roll 35 and a crimper wheel 36. The crimped webs, now a two-ply basesheet, are then appropriately slit between an anvil roll 37 and a slitter roll 38 and wound onto a hardroll 40, from which the tissue web is further converted (folded, interfolded, packaged) into the final tissue product.

#### Examples

##### Example 1: Making the tissue web.

A tissue web was made as illustrated in Figures 1 and 2. More specifically, a layered headbox was used to form a two-layered embryonic web between the felt and the forming wire. The layer against the felt (first layer) consisted of 100 dry weight percent eucalyptus fibers provided as an aqueous slurry having a consistency of about 0.14 weight percent. The layer against the forming wire (second layer) consisted of 100 dry weight percent northern softwood kraft fibers provided as an aqueous slurry having a consistency of about 0.14 weight percent. The forming wire was an 84 mesh polyester fabric manufactured by Appleton Wire Company, Appleton, Wisconsin. The felt was a Yankee pick-up felt also manufactured by Appleton Wire Company. The embryonic layered web was dewatered to a consistency of about 40 weight percent before being transferred to a Yankee dryer with the second layer against the surface of the dryer. Transfer to the dryer was effected with a soft pressure roll having a hardness of about 38 P&J. A creping adhesive consisting of a mixture of polyvinyl alcohol, KYMENE, and Quaker release agent was used to enhance the adhesion of the web to the Yankee dryer. The web was creped at about 5 weight percent moisture and the resulting tissue web was wound onto a softroll.

Two softrolls of tissue webs, each made as described above, were plied together as described above in reference to Figure 2. The two-ply basesheet was converted into two-ply facial tissue having a finished basis weight of about 8.4 kg per 267.6m<sup>2</sup> (18.5 pounds per 2880 square feet) with the first layer of each ply positioned as the outwardly facing surface of the tissue product.

##### Example 2: Making the tissue web.

A two-ply facial tissue was made as described in Example 1, except the furnish of the layer against the felt (first layer) was about 50 dry weight percent eucalyptus fibers and about 50 dry weight percent northern softwood kraft fibers and was unrefined. The furnish of the layer against the forming wire (second layer) was the same, but was highly refined to provide sufficient strength. The finished basis weight of the two-ply facial tissue was about 8.6 kg per 267.6m<sup>2</sup> (19 pounds per 2880 square feet).

##### Example 3: Making the tissue web.

A two-ply facial tissue was made as described in Example 1, except the furnish of the layer against the felt (first layer) was about 55 dry weight percent eucalyptus fibers and about 45 dry weight percent northern softwood kraft fibers and was unrefined. The furnish of the layer against the forming wire (second layer) was the same, but was highly refined to provide sufficient strength. The finished basis weight of the two-ply tissue product was about 8.6 kg per 267.6m<sup>2</sup> (19 pounds per 2880 square feet).

##### Example 4: Consumer evaluations.

Two-ply facial tissues made as described in Examples 1 and 2 were placed with consumers in test cells of 100 subjects each. The consumers were given unidentified sample facial tissues to view and handle and were asked to determine which sample was softer. In the evaluations, tissue samples of Examples 1 and 2 were compared to a commercially-available two-ply facial tissue (PUFFS), each ply of which is layered and having an outer layer of about 100% eucalyptus fibers which during manufacture is positioned against the creping cylinder surface. In the test cells comparing facial tissues of Example 1 versus PUFFS, on average about 58 percent selected Example 1 as being softer, about 20 percent selected PUFFS as being softer, and about 22 percent had no preference. In the test cells comparing facial tissues of Example 2 versus PUFFS, on average about 54 percent selected Example 2 as being softer, about 39 percent selected PUFFS as being softer, and about 7 percent had no preference. In the test cells comparing facial tissues of Example 3 versus PUFFS, on average about 51 percent selected Example 3 as being softer, about 30 percent selected PUFFS as being softer, and about 19 percent had no preference. These results are statistically significant and illustrate that the method of this invention produces tissue products which are superior in

softness, either with an equal percentage or with a lesser percentage of eucalyptus fibers in the outer layer of the tissue. This is not only an advantage from a product performance standpoint, but is also an advantage from an economic standpoint because of the relatively greater expense of eucalyptus fibers compared to softwood fibers.

### Claims

1. A method of making a two-ply tissue product comprising:
  - a) depositing a stratified aqueous slurry of papermaking fibers on a forming wire (2) to form a layered embryonic web, said embryonic web having a first layer (15) of fibers comprising a substantial amount of short fibers and a second layer (16) of fibers which provides most of the strength of the resulting tissue web and is in contacting relationship with the forming wire (2);
  - b) dewatering the embryonic web;
  - c) adhering the dewatered web to the surface drying means (20) and drying the web;
  - d) creping the dried web to form a tissue web;
  - e) converting the tissue web into a two-ply tissue product wherein the first layer (15) of the tissue web is positioned as an outwardly facing surface of the tissue product characterized in that
    - f) said stratified aqueous slurry of papermaking fibers is deposited between said forming wire (2) and a felt (3) to form said layered embryonic web;
    - g) said first layer (15) of fibers is in contacting relationship with said felt (3) and
    - h) said second layer (16) is in contacting relationship with said surface of the drying means (20).
2. The method of claim 1 wherein the drying means (20) is a rotating drying cylinder.
3. The method of claims 1 or 2 wherein the short fibers are hardwood fibers.
4. The method of one of claims 1 to 3 wherein the hardwood fibers are eucalyptus fibers.
5. The method of one of claims 1 to 4 wherein the second layer (16) primarily comprises long fibers.
6. The method of claims 1 to 5 wherein the first layer (15) contains at least about 40 dry weight percent short fibers.

7. The method of claim 6 wherein the amount of short fibers in the first layer (15) is from about 50 to about 60, preferably 55 dry weight percent.
8. A two-ply facial tissue obtainable by the method of one of the preceding claims.

### Patentansprüche

1. Verfahren zur Herstellung eines zweilagigen Tuchprodukts mit den folgenden Schritten:
  - a) Ablegen einer geschichteten, wäßrigen Aufschlämmung aus Fasern zur Papierherstellung auf einem Formsieb (2), um eine geschichtete Rohbahn zu bilden, wobei die Rohbahn eine erste Schicht (15) aus Fasern mit einer wesentlichen Menge an Kurzfasern und eine zweite Schicht (16) aus Fasern aufweist, welche den größten Teil der Festigkeit der resultierenden Tuchbahn liefert und mit dem Formsieb (2) in Berührung steht;
  - b) Entwässern der Rohbahn;
  - c) Anhaften der entwässerten Bahn an der Oberflächentrocknungseinrichtung (20) und Trocknen der Bahn;
  - d) Kreppen der getrockneten Bahn zur Bildung einer Tuchbahn;
  - e) Umwandeln der Tuchbahn in ein zweilagiges Tuchprodukt, bei dem die erste Schicht (15) der Tuchbahn als auswärts gerichtete Oberfläche des Tuchprodukts angeordnet wird
 dadurch gekennzeichnet, daß
  - f) die geschichtete wäßrige Aufschlämmung aus Fasern zur Papierherstellung zwischen dem Formsieb (2) und einem Filz (3) abgelegt wird, um die geschichtete Rohbahn zu bilden;
  - g) die erste Schicht (15) aus Fasern in Berührung mit dem Filz (3) steht und
  - h) die zweite Schicht (16) in Berührung mit der Oberfläche der Trocknungseinrichtung (20) steht.
2. Verfahren gemäß Anspruch 1, bei dem die Trocknungseinrichtung (20) ein rotierender Trockenzylinder ist.
3. Verfahren gemäß Anspruch 1 oder 2, bei dem die Kurzfasern Hartholzfasern sind.
4. Verfahren gemäß einem der Ansprüche 1 bis 3, bei dem die Hartholzfasern Eukalyptusfasern sind.

- |   |                              |  |
|---|------------------------------|--|
| <p>5. Verfahren gemäß einem der Ansprüche 1 bis 4, bei dem die zweite Schicht (16) vorwiegend Langfasern enthält.</p> <p>6. Verfahren gemäß Ansprüchen 1 bis 5, bei dem die erste Schicht (15) mindestens etwa 40 Trockengewichtsprozent Kurzfasern enthält.</p> <p>7. Verfahren gemäß Anspruch 6, bei dem die Menge der Kurzfasern in der ersten Schicht (15) zwischen etwa 50 bis etwa 60, vorzugsweise bei 55 Trockengewichtsprozent liegt.</p> <p>8. Zweilagiges Gesichtstuch, erhältlich durch das Verfahren gemäß einem der vorhergehenden Ansprüche.</p> | <p>5</p> <p>10</p> <p>15</p> | <p>3. Procédé selon la revendication 1 ou 2, dans lequel les fibres courtes sont des fibres de feuillus .</p> <p>4. Procédé selon l'une des revendications 1 à 3, dans lequel les fibres de feuillus sont des fibres d'eucalyptus.</p> <p>5. Procédé selon l'une des revendications 1 à 4, dans lequel ladite seconde couche (16) est constituée fondamentalement de fibres longues.</p> <p>6. Procédé selon l'une des revendications 1 à 5, dans lequel la première couche (15) contient au moins environ 40% en poids sec de fibres courtes.</p> |
|---|------------------------------|--|

### Revendications

- |  |   |   |
|--|---|---|
| <p>1. Procédé de fabrication d'un produit en tissu de papier à deux épaisseurs consistant :</p> <p>(a) à déposer une bouillie aqueuse stratifiée de fibres papetières sur une toile de formation (2) pour former une nappe stratifiée embryonnaire, ladite nappe embryonnaire ayant une première couche (15) de fibres formées d'une quantité substantielle de fibres courtes et une seconde couche (16) de fibres qui fournit la plus grande partie de la résistance à la nappe de tissu résultante et qui est en relation de contact avec la toile de formation (2) ;</p> <p>(b) l'essorage de la nappe embryonnaire ;</p> <p>(c) le collage de la nappe essorée sur la surface d'un moyen de séchage (20) et le séchage de la nappe ;</p> <p>(d) le crêpage de la nappe séchée pour former une nappe de tissu ;</p> <p>(e) la transformation de la nappe de tissu en un produit de tissu à deux épaisseurs dans lequel la première couche (15) de la nappe de tissu est disposée en tant que surface tournée vers l'extérieur du produit de tissu, caractérisé en ce que :</p> <p>(f) ladite bouillie aqueuse stratifiée de fibres papetières est déposée entre ladite toile de formation (2) et un feutre (3) pour former ladite nappe stratifiée embryonnaire,</p> <p>(g) ladite première couche (15) de fibres est en relation de contact avec ledit feutre (3) et</p> <p>(h) ladite seconde couche (16) est en relation de contact avec ladite surface dudit moyen de séchage (20).</p> <p>2. Procédé selon la revendication 1, dans lequel ledit moyen de séchage (20) est constitué d'un cylindre de séchage rotatif.</p> | <p>20</p> <p>25</p> <p>30</p> <p>35</p> <p>40</p> <p>45</p> <p>50</p> <p>55</p> | <p>7. Procédé selon la revendication 6, dans lequel la quantité de fibres courtes dans la première couche (15) va d'environ 50 à environ 60%, et est de préférence de 55%, en poids sec.</p> <p>8. Mouchoir en papier à deux épaisseurs pouvant être obtenu par le procédé selon l'une quelconque des revendications précédentes.</p> |
|--|---|---|

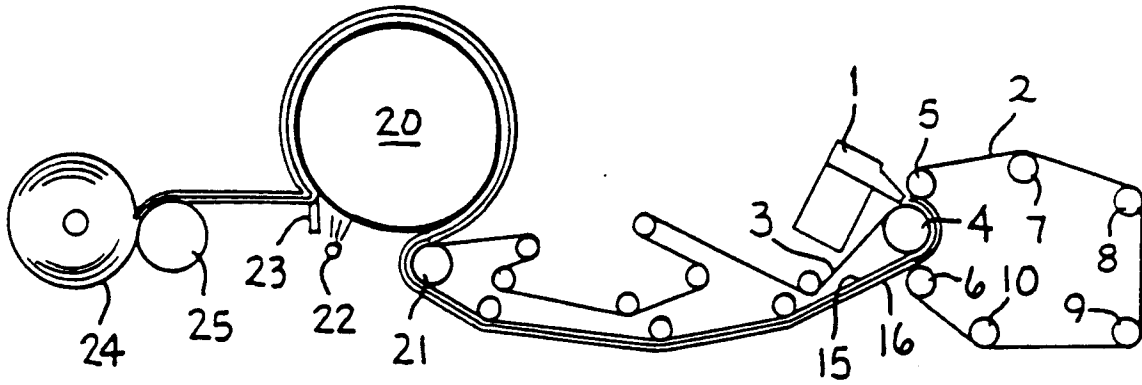

FIG. 1

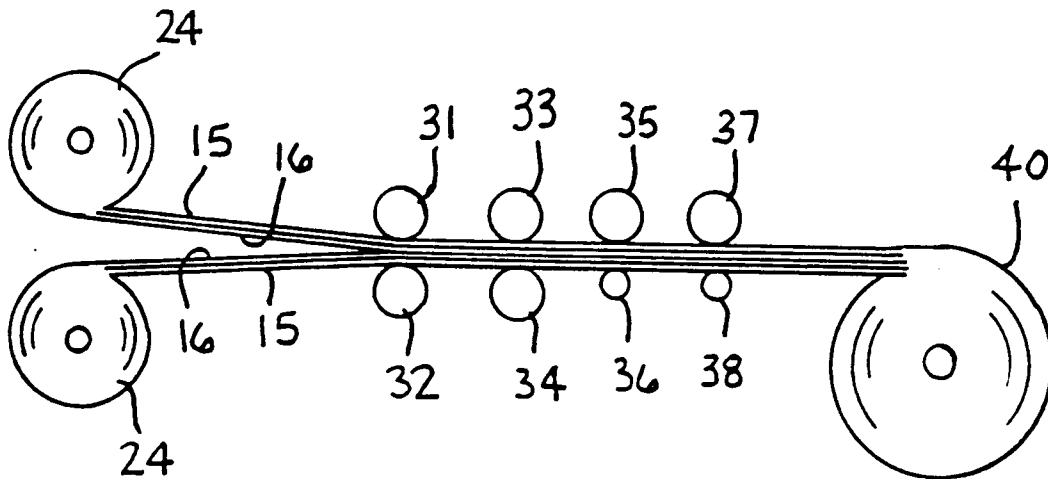

FIG. 2