

(12) STANDARD PATENT
(19) AUSTRALIAN PATENT OFFICE

(11) Application No. **AU 2004309560 B2**

(54) Title
Heat exchanger

(51) International Patent Classification(s)
H01L 23/473 (2006.01) **F28F 9/26** (2006.01)
F28D 9/00 (2006.01) **F25B 21/00** (2006.01)

(21) Application No: **2004309560** (22) Date of Filing: **2004.12.22**

(87) WIPO No: **WO05/064245**

(30) Priority Data

(31) Number	(32) Date	(33) Country
0315257	2003.12.23	FR

(43) Publication Date: **2005.07.14**

(44) Accepted Journal Date: **2009.12.24**

(71) Applicant(s)
Cooltech Applications

(72) Inventor(s)
Heitzler, Jean-Claude;Muller, Christian;Dupin, Jean-Louis

(74) Agent / Attorney
Spruson & Ferguson, Level 35 St Martins Tower 31 Market Street, Sydney, NSW, 2000

(56) Related Art
US 4644385
US 5509468
US 3481393

(12) DEMANDE INTERNATIONALE PUBLIÉE EN VERTU DU TRAITÉ DE COOPÉRATION
EN MATIÈRE DE BREVETS (PCT)

(19) Organisation Mondiale de la Propriété
Intellectuelle
Bureau international



(43) Date de la publication internationale
14 juillet 2005 (14.07.2005)

PCT

(10) Numéro de publication internationale
WO 2005/064245 A3

- (51) Classification internationale des brevets⁷ : F28F 9/26, H01L 23/473
- (71) Déposants et
(72) Inventeurs : MULLER, Christian [FR/FR]; 10, rue Déserte, F-67000 Strasbourg (FR). DUPIN, Jean-Louis [FR/FR]; 56, rue Principale, F-68320 Muntzenheim (FR). HEITZLER, Jean-Claude [FR/FR]; 142, Grand'Rue, F-68180 Horbourg-Wihr (FR).
- (21) Numéro de la demande internationale : PCT/FR2004/003332
- (74) Mandataire : NITHARDT, Roland; Cabinet Nithardt et Associés S.A., B.P. 1445, F-68071 Mulhouse Cedex (FR).
- (22) Date de dépôt international : 22 décembre 2004 (22.12.2004)
- (25) Langue de dépôt : français
- (81) États désignés (sauf indication contraire, pour tout titre de protection nationale disponible) : AE, AG, AL, AM, AT, AU, AZ, BA, BB, BG, BR, BW, BY, BZ, CA, CH, CN, CO, CR, CU, CZ, DE, DK, DM, DZ, EC, EE, EG, ES, FI, GB, GD, GE, GH, GM, HR, HU, ID, IL, IN, IS, JP, KE, KG, KP, KR, KZ, LC, LK, LR, LS, LT, LU, LV, MA, MD, MG, MK, MN, MW, MX, MZ, NA, NI, NO, NZ, OM, PG, PH,
- (26) Langue de publication : français
- (30) Données relatives à la priorité : 0315257 23 décembre 2003 (23.12.2003) FR

[Suite sur la page suivante]

(54) Title: HEAT EXCHANGER

(54) Titre : ECHANGEUR THERMIQUE

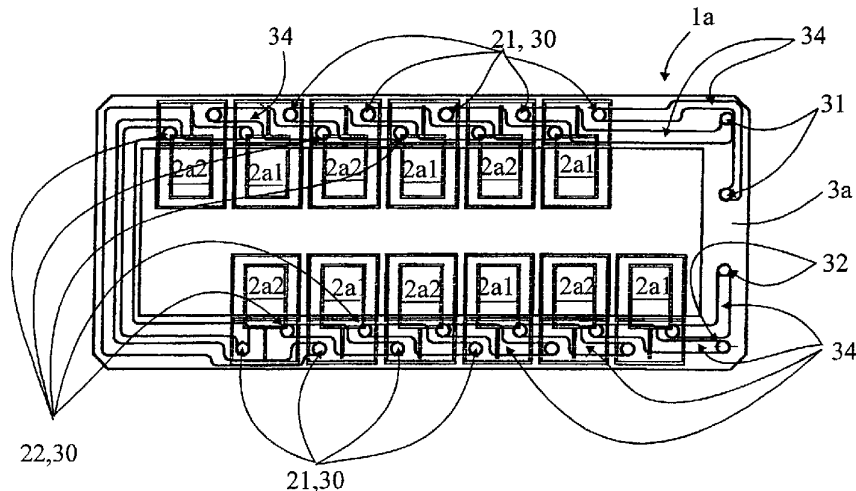

(57) Abstract: The invention relates to a heat exchanger permitting, in an efficient, simple and reliable manner and for a moderate cost, the connection in series, in parallel or according to a mixed configuration of thermal elements to one another and to an external circuit while limiting the risks of leakage and the number of connections. The heat exchanger (1a) comprises calorie-emitting and negative calorie-emitting thermal elements (2a1, 2a2) each of which being passed through by a conduit whose inlet orifices (21) and outlet orifices (22) are connected to one another and to at least one thermal fluid circuit by an interface plate (3a) situated above a closing plate (5a) and defining two interface circuits (4a1, 4a2). The interface plate (3a) also comprises two supply orifices (31) and two discharge orifices (32) for connecting the interface circuits to two external circuits hot and cold suited for using the calories and the negative calories recovered from said thermal fluid. The inventive heat exchanger is to be used for cooling, heating, air-conditioning, and regulating temperature in any type of installation.

[Suite sur la page suivante]

WO 2005/064245 A3



PL, PT, RO, RU, SC, SD, SE, SG, SK, SL, SM, SY, TJ, TM, TN, TR, TT, TZ, UA, UG, US, UZ, VC, VN, YU, ZA, ZM, ZW.

(84) **États désignés** (sauf indication contraire, pour tout titre de protection régionale disponible) : ARIPO (BW, GH, GM, KE, LS, MW, MZ, NA, SD, SL, SZ, TZ, UG, ZM, ZW), eurasién (AM, AZ, BY, KG, KZ, MD, RU, TJ, TM), européen (AT, BE, BG, CH, CY, CZ, DE, DK, EE, ES, FI, FR, GB, GR, HU, IE, IS, IT, LT, LU, MC, NL, PL, PT, RO, SE, SI, SK, TR), OAPI (BF, BJ, CF, CG, CI, CM, GA, GN, GQ, GW, ML, MR, NE, SN, TD, TG).

Publiée :

- avec rapport de recherche internationale
- avant l'expiration du délai prévu pour la modification des revendications, sera republiée si des modifications sont reçues

(88) **Date de publication du rapport de recherche internationale:**

9 septembre 2005

En ce qui concerne les codes à deux lettres et autres abréviations, se référer aux "Notes explicatives relatives aux codes et abréviations" figurant au début de chaque numéro ordinaire de la Gazette du PCT.

(57) **Abrégé :** La présente invention concerne un échangeur thermique permettant, de manière efficace, simple, fiable et pour un coût modéré, de raccorder en série, en parallèle ou selon une configuration mixte, des éléments thermiques entre eux et à un circuit extérieur, en limitant les risques de fuite et le nombre de raccords. L'échangeur thermique (1a) comporte des éléments thermiques (2a1, 2a2) émetteurs de calories et de frigories traversés chacun par un conduit dont les orifices d'entrée (21) et de sortie (22) sont reliés entre eux et à au moins un circuit de fluide thermique par une plaque d'interface (3a) superposée à une plaque d'obturation (5a) et définissant deux circuits d'interface (4a1, 4a2). La plaque d'interface (3a) comporte également deux orifices d'arrivée (31) et deux orifices d'évacuation (32) pour raccorder les circuits d'interface à deux circuits extérieurs « chaud » et « froid » agencés pour utiliser les calories et les frigories récupérées par ledit fluide thermique. Application : Echangeur thermique pour refroidissement, chauffage, climatisation, tempérage dans tout type d'installation.

HEAT EXCHANGER

Technical Field:

5 The present invention concerns a heat exchanger comprising at least one group of at least two calorie- and/or frigorie-emitting thermal elements, each equipped with at least one inlet orifice and at least one outlet orifice joined through at least one conduit traversing the thermal element, capable of receiving a thermal fluid for recovering the calories and/or frigories, said heat exchanger comprising means for interconnecting the conduits and at
10 least one circuit external to the heat exchanger to utilize the calories and/or frigories recovered by said thermal fluid.

Prior Art:

15 In the conventional manner, traditional heat exchangers comprise thermal elements connected to one another and to one or more external thermal fluid circuits using pipes, connectors, and seals. The connectors are preferably removable to facilitate installation and maintenance operations. This connection technique takes a long time to perform, requires a large number of parts, and makes achieving a tight seal on this type of heat
20 exchanger difficult.

One example is illustrated in Publication WO-A-03/050456 which describes a magneto-caloric heat exchanger comprising twelve gadolinium based thermal elements alternately subjected to a magnetic field generated by a rotating permanent magnet. Each thermal
25 element is provided with a minimum of four orifices, two inlet orifices and two outlet orifices, connected in pairs by conduits and joined to the external "hot" and "cold" circuits by turning seals. Each turning seal comprises seven connections selectively joining the conduits, depending upon the position of the permanent magnet, to the "hot" and "cold" external circuits. Thus, this heat exchanger comprises four turning seals per thermal
30 element, either 48 connectors to which seven connections are added for each of the four

turning seals, or 28 additional connectors, for a total of 76 connections. This large number of connectors proportionately increases the number of mechanical parts as well as increasing the risk of thermal fluid leaks. Moreover, it imposes considerable technical limitations on the heat exchanger that make it economically impractical. This is, therefore, not a very satisfactory solution.

Another connection technique is illustrated in Publications US-A-4,644,385 and US-A-5,509,468, which provide for the pipes to be replaced by rigid plates integrating the circulation channels for cooling fluid in radiators for electronic circuits. In this type of application, the radiator comprises for each electronic circuit an individual plate for absorbing the dissipated calories, connected to a collector plate coupled with a heat exchanger. However, the connection between the different plates and the heat exchanger requires specific rigid or flexible connectors which may or may not include a valve. Thus, this solution does not eliminate the need for connecting parts with their associated disadvantages. Moreover, in this type of application, the cooling circuit is fixed rather than evolving, with its objective being simply the dissipation of calories.

Object of the Invention

It is the object of the present invention to substantially overcome or ameliorate one or more of the disadvantages of the prior art.

Summary of the Invention

The present invention provides a heat exchanger comprising at least one group of at least two calorie- or frigorie-emitting thermal elements, each provided with at least one inlet orifice and at least one outlet orifice connected by at least one conduit traversing said thermal element capable of receiving thermal fluid designed to recover said calories and/or said frigories, said heat exchanger comprising connection means designed to connect said conduits to one another and to at least one circuit external to said heat exchanger designed to utilize the calories and/or frigories recovered by said thermal fluid, wherein said connection means comprises at least one interface plate placed flat against said thermal elements, comprising at least one channel equipped with connecting orifices facing the inlet orifices and outlet orifices in said thermal elements and defining at least one interface circuit allowing said thermal fluid to circulate between said thermal elements and said interface plate through a series, parallel, or mixed connection, said interface plate also comprising at least one supply orifice and at least one discharge orifice which connect said interface circuit to said exterior circuit.

In a preferred embodiment of the invention, the thermal elements alternately emit calories and frigories and the interface plate comprises at least two channels, each equipped with at least one supply orifice, one evacuation orifice, and connecting orifices, and disposed so as to define two distinct interface circuits connected to two external
5 circuits.

Advantageously, the heat exchanger comprises at least two groups of thermal elements, each provided with at least one interface plate, and complementary connection elements designed to connect the interface plates to each other and to the interface circuits in said corresponding groups in a series, parallel or mixed connection.

10 According to a variation, the connection elements comprise at least two interface plates superimposed back to back, each comprising at least one channel, one supply orifice, one discharge orifice, and connecting orifices joined to a unit of thermal elements. These interface plates may comprise traversing orifices facing each other defining a common interface circuit.

15 The channel may be at least partially formed of a network of perforations through the interface plate and selectively blocked by plugs depending upon the interface circuit desired.

The channel may also be at least partially formed of one or more grooves on at least one surface of the interface plate, formed by machining, engraving, or casting. In
20 this case, the connection elements advantageously comprise at least one closing plate superimposed on

the interface plate on the side with the groove to form the channel.

The closing plate may be located between two interface plates in order to form a channel with each one. This closing plate may comprise traversing orifices opening into said
5 channels and designed to connect them in a series, parallel, or mixed connection.

Preferably, the connecting means are made of a thermally insulating material and comprise seals located at least between the thermal elements and the interface plates, said seals possibly consisting of a coating or a sheet of Teflon, a liquid seal, or the like.
10

According to a preferred embodiment, the closing plate comprises a switch movable between at least two positions in order to modify the mode of connection between said interface circuits. This switch may be chosen from the group comprising at least a slide block , a core, or a sliding unit and controlled by a driving means.
15

Brief Description of the Drawings:

The present invention and its advantages will be more apparent from the following description of several embodiments, with reference to the attached drawings, provided by
20 way of non-limiting examples, wherein:

- Figures 1A-C are respectively views from above, from the side, and a transparent overhead view of a first embodiment of a heat exchanger according to the invention;
- Figure 1D is a view similar to Figure 1C in which the hot and cold thermal circuits
25 are shown schematically;
- Figures 1E and 1F are cross-sections along lines AA and BB of the single interface plate of the heat exchanger of Figure 1D;
- Figures 1G and 1H are cross-sections of the heat exchanger in the preceding drawings in which the hot and cold thermal circuits are shown schematically;
- 30 - Figures 1I and 1J are exploded perspective views, from above and below, of the

heat exchanger in the preceding drawings;

- Figures 2A, 2B and 2D are exploded perspective views from below, from above, and a side view, respectively, of a second embodiment of the heat exchanger according to the invention;
- 5 - Figure 2C is a view similar to Figure 1D of the heat exchanger of Figure 2A;
- Figures 3A and 3B are views from above and from the side, respectively, of a third embodiment of the heat exchanger of the invention;
- Figure 3C illustrates assembly by superimposing the interface plates and the closing plate to form the connection means for the heat exchanger of Figures 3A, B;
- 10 - Figures 3D and 3E are exploded perspective views from above and below the heat exchanger of Figures 3A-C;
- Figures 4A-D are cross-sectional side views of several embodiments of the connection means for the heat exchanger according to the invention;
- Figures 5A, 6A, 7A are overhead views of three other embodiments of heat exchangers according to the invention;
- 15 - Figures 5B, 6B, 7B are views similar to Figures 5A, 6A, 7A with their hot and cold thermal circuits shown schematically;
- Figures 8A and 8B are overhead views of another embodiment of a heat exchanger, according to the invention, with a portion of the hot and cold thermal circuits shown schematically on each one;
- 20 - Figures 9A and 9B are partially exploded and unexploded complete perspective views, respectively, of another embodiment of the heat exchanger of the invention; and
- Figures 10 and 11A-C are perspective views of other embodiments of the heat exchanger according to the invention.
- 25

Illustrations of the Invention:

With reference to the drawings, and in known manner, the heat exchanger 1a-o comprises
30 one or several groups 200a-o of calorie- and/or frigorie-emitting thermal elements 2a-o on

a support to which they are attached by a permanent or temporary attachment means (not shown), such as, for example, gluing, soldering, bolting, setting, or casting.

In the examples shown, thermal elements 2a-o are the magneto-calorie type. It is obvious
5 that they could be any other type functioning according to any other adapted principle. Each thermal element 2a-o contains a magneto-calorie material such as gadolinium (Gd), for example, or any other equivalent material. Thus, when thermal element 2a-o is subjected to the presence of a magnetic field, it heats up and when the magnetic field disappears, it cools to a temperature lower than its initial temperature. The operating
10 principle of heat exchangers 1a-o, given by way of example, consists, therefore, of alternately subjecting thermal elements 2a-o to the presence and absence of a magnetic field and recovering the calories and/or frigories successively emitted by each thermal element 2a-o using a circulating thermal fluid. In order to do this, the magnetic field is designed to be movable relative to the thermal elements and/or variable, and each thermal
15 element 2a-o is traversed by at least one conduit 20 with its inlet orifices 21 and outlet orifices 22 connected by connecting means 3a-o to one or more external circuits (not shown) through which the thermal fluid is caused to circulate and the calories and/or frigories are used in a piece of equipment to heat, cool, air condition, or regulate the temperature of the atmosphere.

20

The number of thermal elements 2a-o provided in each group 200a-o can be adapted to need and to the type of operation desired.

In the examples shown, conduit 20 traversing thermal elements 2a-o is U-shaped.
25 Obviously, it could have any other adapted shape. According to a variation that is not shown, conduit 20 may comprise, for example, an internal chamber to receive magneto-caloric material which may consist of pellets.

The magnetic field may be generated by permanent magnets, for example, or by magnetic
30 assemblies (not shown) overlapping elements 2a-o and alternated to exert force on every

other thermal element 2a-o. The magnetic field may also be generated by adjacent permanent magnets (not shown) alternately and simultaneously exerting force on all the thermal elements 2a-o. The permanent magnets are fixed or coupled with displacement means (not shown) to make them movable relative to thermal elements 2a-o. These
5 displacement means may be alternating, stepping, or continuous and they may generate rotating, pivoting, translational, or any combination of movement on the part of the permanent magnets; the trajectory may follow a helical, circular, sinusoidal translational path or any other adapted translational trajectory. The displacement means may comprise, for example, a motor, a cylinder, a spring mechanism, an aerogenerator, an electromagnet,
10 a hydrogenerator, or any other equivalent means. The permanent magnets may also be aligned side by side to attract all the thermal elements in a single series.

According to the invention, the connection elements for the heat exchanger 2a-o comprise at least one interface plate 3a-o provided with one or more channels 34. These channels 34
15 comprise connecting orifices 30 joined directly to inlet orifice 21 and outlet orifice 22 allowing communication between conduits 20 in the different thermal elements 2a-o and defining one or more interface circuits 4a-o so as to allow thermal fluid to circulate between thermal elements 2a-o. This interface plate 3a-o is also equipped with one or more supply orifices 31 and discharge orifices 32 for connecting the interface circuit or circuits
20 4a-o with one or more external circuits, for example, a hot external circuit and a cold external circuit.

In the examples shown in Figures 1-8, thermal heat exchangers 1a-j each comprise a single group 200a-j of thermal elements 1a-j, whereas with reference to Figures 9-11, heat
25 exchangers 1k-o each comprise several groups 200k-o of thermal elements 1k-o. The purpose of these different examples is to show the multiple combinations that are possible with the present invention.

With reference to Figures 1A-J and according to a first embodiment, heat exchanger 1a
30 comprises a group 200a of two rows of six alternating thermal elements 2a1, 2a2 joined to

an interface plate 3a forming a rectilinear frame. Thermal elements 2a1, 2a2 are simultaneously subjected to the presence and absence of a magnetic field and are joined to interface plate 3a so as to define two distinct interface circuits 4a1, 4a2. This heat exchanger 1a therefore allows simultaneous recovery of the calories emitted by thermal elements 2a1 in a first unit by means on the first interface circuit 4a1 and of the frigories emitted by thermal elements 2a2 on the second unit by means of the second interface circuit 4a2, and vice versa.

Interface plate 3a may be made of a thermally insulating, mechanically rigid material such as, for example, a composite or synthetic material or other equivalent material. It may also be made of a thermally conductive material such as a metal alloy or porcelain and it may be thermally insulated at the exterior walls, for example, using some type of adapted covering. This interface plate 3a comprises four orifices, of which two supply orifices 31 and two discharge orifices 32 are connected by conventional connection means (not shown) to two external circuits (not shown), one being a hot exterior circuit and one a cold external circuit.

A switching means (not shown) may be interposed for toggling between one exterior circuit and the other, and vice versa. The switching means allows each interface circuit 4a1, 4a2 to be connected alternately to the exterior hot circuit and then the exterior cold circuit. It may comprise valves, electrically, pneumatically or hydraulically controlled slide mechanisms, or any other adapted means. The exterior circuits comprise free or forced thermal fluid circulation means (not shown) such as for example a pump or other equivalent means. Each hot or cold external circuit is additionally equipped with one or more heat exchangers for calories or frigories, respectively, or other equivalent means allowing diffusion and utilization of these calories and frigories. Depending upon the application, the external circuits may also comprise a means for reversing the direction in which the thermal fluid circulates.

Interface plate 3a is designed to lie flat against thermal elements 2a and to ensure

connection by means of simple contact without any additional mechanical connector. For this purpose, it comprises connecting orifices 30 joined in pairs by grooves formed on the surface of interface plate 3a opposite thermal elements 2a1, 2a2, these connecting orifices 30 facing inlet orifices 21 and outlet orifices 22 on each thermal element 2a1, 2a2.

5 Interface plate 3a is superimposed on a closing plate 5a by the grooves to form channel 34. Interface plate 3a, closing plate 5a, and thermal elements 2a1, 2a2 are assembled with seals (not shown) such as, for example, a sheet of Teflon, a liquid seal, or a specific coating. These sealing elements, when provided between interface plate 3a and thermal elements 2a1, 2a2, comprise orifices for the passage of thermal fluid facing connecting orifices 30.

10

The grooves are arranged so as to connect inlet orifice 21 of the first thermal element 2a1, 2a2 of each unit to a supply orifice 31 and a discharge orifice 22 of the last thermal element 2a1, 2a2 of each unit to a discharge orifice 32. Excluding the already connected inlet orifices 21 and outlet orifices 22, on each unit the grooves connect the outlet orifice 22 of one thermal element 2a1, 2a2 to the inlet orifice 21 on the next thermal element 2a1, 2a2. Thermal elements 2a1 and 2a2 in the same unit are thus respectively connected in series. In order to avoid any crossover between interface circuits 4a, the grooves follow a semi-crenellated tangled trajectory. The grooves may be formed by machining, stamping, or casting.

20

Interface plate 3a, such as the one shown, may easily be adapted to a larger number of thermal elements 2a in order to increase the thermal capacity of heat exchanger 1a.

The operation of heat exchanger 1a can be broken down into two stages, between which the switching means are toggled and the magnetic field is modified. Thus, as each stage changes, the first unit of thermal elements 2a1 previously subjected to the magnetic field is subjected to the absence of magnetic field, and conversely for the second unit of thermal elements 2a2. Moreover, the first interface circuit 4a1 previously connected to the exterior hot circuit is connected to the exterior cold circuit, and conversely for the second interface circuit 4a2.

30

In a first stage of operation, thermal elements 2a1 on the first unit subjected to the magnetic field heat up and heat the thermal fluid present in first interface circuit 4a1. In parallel, thermal elements 2a2 on the second unit, which are no longer subjected to the magnetic field, cool down, reaching a temperature that is lower than their initial temperature and cooling the thermal fluid present in second interface circuit 4a2.

In this series configuration, thermal fluid enters interface plate 3a through one of the supply orifices 31. The thermal fluid in the first interface circuit 4a1 is heated to a temperature $+t_1$ by first thermal element 2a1 on the first unit subjected to the magnetic field. It is then guided by channel 34 toward second thermal element 2a1 which heats it to a temperature $+t_2$, higher than $+t_1$, and so forth, until reaching the last thermal element 2a1. Next, the heated thermal fluid exits interface plate 3a through one of the discharge orifices 32, guided toward the external hot circuit where the calories are evacuated, recovered, and utilized, using one or more calorie exchangers, for example.

Simultaneously, the thermal fluid in second interface circuit 4a2 is cooled down to a temperature $-t_1$ by first thermal element 2a2 on the second unit not subjected to the magnetic field. It is then guided by channel 34 toward second thermal element 2a2 which cools it to a temperature $-t_2$, lower than $-t_1$, and so forth, until reaching the last thermal element 2a2. Next, the cooled thermal fluid exits interface plate 3a through the other evacuation orifice 32, guided toward the external cold circuit where the frigories are evacuated, recovered, and utilized, using one or more frigorie exchangers, for example.

The second stage is essentially similar to the first stage, with heating thermal elements 2a1 becoming cooling and cooling thermal elements 2a2 becoming heating. The operation continues by alternating between the first and second stages.

Heat exchanger 1a in this first embodiment may be connected to another similar or dissimilar heat exchanger 1a in series, in parallel or a mixture of series/parallel. This connection may be done conventionally using pipes or using an interface connecting plate

(not shown) allowing interface plates 3a of each heat exchanger 1a to communicate, or even using multiple interface plates to replace the two interface plates 3a and the connecting plate.

5 Best Way to Achieve the Invention:

With reference to Figures 2A-D and according to a preferred embodiment of the invention, heat exchanger 1b, essentially similar to the preceding one, is differentiated by its circular configuration, which allows activation of the magnetic elements in a continuous circular
10 movement instead of the rectilinear, alternating movement in the case of the linear configuration. It comprises a group 200b of twelve thermal elements 2b1, 2b2 in the form of circular sections supported by an interface plate 3b forming a ring and provided with four openings, two of which are supply orifices 31 and two of which are discharge orifices 32. Connecting orifices 30 and channels 34 provided in interface plate 3b are essentially
15 similar to the preceding elements. Interface plate 3b is attached to a closing plate 5b comprising traversing orifices 40 facing supply orifices 31 and discharge orifices 32 on interface plate 3b. Thermal elements 2b1, 2b2 and interface plate 3b define two interface circuits 4b1, 4b2. The operation of this heat exchanger 1b is essentially similar to the preceding one. Heat exchanger 1b of this second embodiment can also be connected to
20 another similar or dissimilar heat exchanger 1b in series, in parallel or a series/parallel mixture.

According to a third embodiment shown by Figures 3A-E, heat exchanger 1c comprises a group 200c consisting of two superimposed and combined heat exchangers essentially
25 similar to those of Figures 1A-J. This heat exchanger 1c therefore comprises four rows of six thermal elements 2c1, 2c2, two rows being supported by a first interface plate 3c1 and two other rows being supported by a second interface plate 3c2 superimposed on first plate 3c1. Each interface plate 3c1, 3c2 is similar to interface plate 3a. It comprises four orifices, two supply orifices 31 and two discharge orifices 32, connecting orifices 30 and
30 channels 34 identically organized. Interface plates 3c1, 3c2 are separated by a closing plate

5c comprising traversing orifices 50 facing supply orifices 31 and discharge orifices 32 on the two interface plates 3c1, 3c2 to connect their interface circuits (not shown) in parallel. Interface plates 3c1 and 3c2 and closing plate 5c are assembled using permanent or temporary attachment means such as, for example, gluing, soldering, screwing, setting, casting. The operation of this heat exchanger 1c is essentially similar to that of Figures 1A-5 J. Interface plates 3c1, 3c2 may be made differently, one connecting thermal elements 2c1, 2c2 which it supports in series, and the other connecting thermal elements 2c1, 2c2 which it supports in parallel as described below. In the example described, supply orifices 31 and discharge orifices 32 on the two interface plates 3c1, 3c2 are superimposed and connected 10 in parallel by orifices 50 traversing closing plate 5 and then connected to the external circuits.

According to a first variation which is not shown, it is possible to join interface plates 3c1, 3c2 in series, for example, by providing that closing plate 5c comprises:

- 15 - a supply orifice connected to the supply orifice on a first interface plate 3c1;
 - a channel connecting the discharge orifice on said first interface plate 3c1 to a supply orifice on second interface plate 3c2;
 - a discharge orifice connected to the discharge orifice of second interface plate 3c2,
- with the channel possibly being formed by a groove or by a perforation.

20

According to a second variant shown in Figure 4A, heat exchanger 1d, only the connecting elements of which are shown, comprises interface plates 3d1, 3d2 separated by a closing plate 5d preventing any passage of thermal fluid between the two.

25 According to a third variant shown in Figure 4B, heat exchanger 1e, only the connecting elements of which are shown, comprises interface plates 3e1, 3e2 separated by a closing plate 5e equipped with traversing orifices 50 allowing thermal fluid to pass through them to define a common interface circuit.

30 According to a fourth variant not shown, the heat exchanger may comprise superimposed

interface plates without any closing plate. In this case the channels in these interface plates may comprise one or more traversing orifices 20 allowing thermal fluid to pass from one to the other to define a common interface circuit.

- 5 According to a fifth variation not shown, the thermal exchanger comprises interface plates having channels without any traversing orifice, with the interface circuits remaining independent.

10 Figures 4C and 4D show a sixth variant wherein closing plate 5f comprises a switch 6 movable between an open position (cf. Figure 4C) and a closed position (cf. Fig. 4D). In the open position switch 6 allows passage of thermal fluid into one portion of closing plate 5f from one interface plate 3f1 to the other interface plate 3f2, and defines a portion of the interface circuit. In the closed position (cf. Fig. 4D) switch 6 prevents the passage of thermal fluid through a portion of closing plate 5f. In this example, switch 6 is a circular
15 core with circular grooves 60. In the open position, circular grooves 60 are aligned with traversing orifices 50 on closing plate 5f allowing them to communicate. In the closed position circular grooves 60 are offset to prevent communication.

20 According to other embodiments not shown, switch 6 may be a slide block or a sliding element with its translational or rotational movement regulated by a control means associated with the elements driving the permanent magnets. It is also possible for switch 6 to move between a larger number of positions. Switch 6, depending on its position, its design, and that of the traversing orifices, effects the connection of the interface circuits on interface plates 3f1, 3f2 in series, in parallel, or a series/parallel mixture.

25 According to a fourth embodiment illustrated by Figures 5A and 5B, heat exchanger 1g comprises a group 200g of two rows of four interface elements 2g1, 2g2 supported by an interface plate 3g forming a rectilinear frame. This interface plate 3g comprises two channels 34 designed so as to connect in parallel:

- 30 - all the inlet orifices 21 of thermal elements 2g1 in a first unit with a first supply

orifice 31;

- all the outlet orifices 22 of thermal elements 2g1 in the first unit with a first discharge orifice 32 and similarly,

5 - all the inlet and outlet orifices 21 and 22 on thermal elements 2g2 of second unit 2, respectively, with second supply orifices 31 and discharge orifices 32.

This configuration thereby allows the definition of two interface circuits 4g1 and 4g2, within each of which the interface elements 2g1 and 2g2 are respectively connected in parallel. As in the preceding examples, supply orifices 31 and discharge orifices 32 on interface plate 3g are connected to external circuits.

10

The operation of this heat exchanger 1g can be broken down into two stages:

15 - a first stage in which thermal elements 2g1 on the first unit, which are subject to the magnetic field are heated and simultaneously heat the thermal fluid present in first interface circuit 4g1 and wherein, simultaneously, thermal elements 2g2 on the second unit, which are not subjected to the magnetic field are cooled and simultaneously cool the thermal fluid present in second interface circuit 4g2; and

- a second step in which the situation is reversed, with thermal elements 2g1 of the first unit, which are no longer subjected to the magnetic field cooling down, and thermal elements 2g2 of the second unit, which are subjected to the magnetic field heating up.

20 The passage from one stage to the other takes place through the switching elements and by displacing the magnetic field.

In this parallel configuration the thermal fluids simultaneously enter interface plate 3g through two supply orifices 31. The thermal fluid in first interface circuit 4g1 is simultaneously reheated to a temperature $+t$ by the unit of thermal elements 2g1 in the first unit subjected to the magnetic field. It is then guided toward the exterior of interface plate 3g by a first discharge orifice 32 toward the external hot circuit where the calories are evacuated, recovered, and utilized, for example, by means of one or more calorie exchangers. At the same time, the thermal fluid in second circuit 4g2 is simultaneously cooled to a temperature $-t$ by the unit of thermal elements 2g2 on the second unit not

25

30

subjected to the magnetic field. It is then guided toward the exterior of interface plate 3g by second evacuation orifice 32 toward the external cold circuit where the frigories are evacuated, for example, by means of one or more frigorie exchangers.

5 With reference to Figures 6A and 6B and according to a fifth embodiment, heat exchanger 1h, essentially similar to the preceding one, is differentiated by its channels 34 formed of a network of perforations traversing interface plate 3h. These traversing perforations, which may be formed by casting, machining, or any other adapted technique, are equipped with stoppers (not shown) permitting selective blockage to form interface circuits 4h1, 4h2.

10 According to the configuration chosen, these traversing perforations may be located on a single level within interface plate 3h or on different levels, thereby preventing crossover. This solution offers the advantage of not requiring any closing plate. The operation of this heat exchanger 1h is essentially similar to the preceding one, with thermal elements 2h1, 2h2 in each unit being connected in parallel to define two interface circuits 4h1, 4h2.

15

With reference to Figures 7A and 7B and according to a sixth embodiment, heat exchanger 1i, essentially similar to the one in Figures 5A and 5B, is differentiated by the fact that each of its thermal elements 2i is traversed by two conduits and thus comprises four orifices, two of which are inlet orifices 21 and two of which are outlet orifices 22. Channels 34 on interface plate 3i simultaneously connect all the thermal elements 2i to a first interface circuit 4i1 and these same thermal elements 2i to a second interface circuit 4i2, said interface circuits 4i1 and 4i2 being independent. The operation of this heat exchanger 1i can be broken down into two stages represented schematically and superimposed in Figure 7B:

25 - a first stage in which all the thermal elements 2i are subjected to the magnetic field, heating up and heating the thermal fluid present in the first interface circuit 4i1; and

- a second step in which all the thermal elements 2i are no longer subjected to the magnetic field, cooling down and cooling the thermal fluid present in the second interface circuit 4i2.

30 The passage from one stage to the other is obtained by alternately supplying the fixed

electromagnets facing thermal elements 2i. This heat exchanger 1i can obviously be combined with another similar or dissimilar thermal exchanger 1i, by a connecting interface plate, or any other adapted means.

5 Figure 8A shows a heat exchanger 1j essentially similar to the preceding one. Thermal elements 2j1 and 2j2 supported by interface plate 3j are traversed by two conduits connected in series. The operation of this thermal heat exchanger 1j can be broken down into two stages, shown separately by Figures 8A and 8B, essentially similar to the two stages of heat exchanger 1a in Figures 1A-J. This configuration is special because conduits
10 20 of thermal elements 2j1, 2j2 and channels 34 define four interface circuits 4j1, 4j2, 4j3, and 4j4. In effect, this heat exchanger 1j eliminates the need for switching means necessary to alternately connect thermal elements 1j to the external hot and cold circuits. This thermal heat exchanger 1j may obviously be combined with another similar or dissimilar thermal exchanger 1j, by a connecting interface plate, or any other adapted means.

15

With reference to Figures 9-11, heat exchangers 1k-o comprise several groups 200k-o of thermal elements 2k-o and complementary connection means 300k-o allowing them to communicate. In these examples, the complementary connection means are joined to interface plates 3k-o and comprise one or more complementary channels 340 connecting
20 channels 34 (not shown in these drawings) in each group 200k-o.

In the example shown in Figures 9A and 9B, heat exchanger 1k comprises two groups 200k, 200k' of thermal elements 2k, 2k' each equipped with an interface plate 3k 3k' essentially similar to that of Figures 2A-C. Interface plates 3k, 3k' comprise lateral
25 extensions 300k, 300k' extending axially, comprising a complementary channel 340 and defining the complementary connection means. Complementary channel 340 in each lateral extension 300k, 300k' comprises two conduits 341, 342 and two orifices 343 for connection to an exterior circuit or to another interface plate. Groups 200k, 200k' are superimposed such that conduits 341, 342 are each located in the extension of the other.
30 Conduits 341, 342 are therefore provided to define a complementary connecting circuit

joining the interface circuits in each group 200k, 200k' in series, in parallel, or in a mixed series/parallel combination.

Heat exchanger 1l shown in Figure 10 is constructed in a manner essentially similar to the preceding one. It comprises four groups 200l, 200l', 200l'' of thermal elements 2l, 2l', 2l'' (only three of which are represented), supported by two pairs of interface plates 3l, 3l' allowing the groups 200l, 200l', 200l'' to be arranged side by side in pairs and stacked. Each pair of interface plates 3l, 3l' comprises a lateral extension 300l, 300l' equipped with conduits 341, 342 and connecting orifices (not shown) provided to define a complementary connecting circuit joining the interface circuits of groups 200l, 200l', 200l'' in series, in parallel, or in a mixed series/parallel combination. It is obviously possible to provide triple interface plates or other numbers in order to have multiple groups of thermal elements.

Heat exchangers 1m-o shown in Figures 11A-C are constructed in a manner essentially similar to those in Figures 3A-E.

Heat exchanger 1m in Figure 11A comprises three groups 200m, 200m', 200m'' of thermal elements 2m, 2m', 2m'' superimposed by interface plates 3m, 3m', 3m''. Two of the interface plates 3m, 3m', 3m'' comprise two lateral extensions 300m, 300m' equipped with conduits 341, 342 and with connecting orifices 343 to define a complementary connecting circuit joining the interface circuits of the different groups in series, in parallel, or in a series/parallel combination.

Heat exchanger 1n in Figure 1B comprises two groups 200n, 200n' of thermal elements 2n, 2n' supported by a single interface plate 3n allowing groups 200n, 200n' to be aligned side by side. Said interface plate 3n comprises complementary a channel (not shown) for connecting the interface circuits of groups 200n, 200n' in series, in parallel, or in a series/parallel combination. In addition, it comprises connecting orifices 343 to allow connection to an external circuit or to another interface plate.

Heat exchanger 1o in Figure 11C combines the two preceding examples by allowing the superimposition combined with the side-by-side alignment of three groups 200o, 200o', 200o'' of thermal elements 2o, 2o', 2o'' and connecting them through a complementary circuit using two interface plates 3o, 3o'.

5

These last embodiments allow the configuration and operation of the heat exchangers of the invention to be modified at will in order to produce stronger thermal power or higher thermal intensity.

10 In these examples, the magnetic fields are generated by permanent magnets, movable magnetic assemblies, or fixed alternately supplied electromagnets. Obviously, they could be generated by any other equivalent means.

Possibilities for Industrial Applications:

15

This description clearly shows that heat exchanger 1a-o of the invention responds to the stated objectives. More specifically, it provides a simple, reliable means of connecting a significant number of thermal elements 2a-o by replacing pipes and conventional connections with an interface plate 3a-o integrating channels 34 in the form of grooves and/or perforations, and connectors in the form of connecting orifices 30 and traversing orifices 40, 50. This interface allows the simultaneous connection of thermal elements 2a-o in a single group 200 a-o and/or several distinct groups 200a-o and/or several heat exchangers 1a-o in a series, parallel, or a mixed connection, configurations that are currently difficult or impossible to achieve. The significantly smaller number of mechanical parts leads to increased reliability in use, limits leakage, and reduces both the manufacturing and maintenance costs of heat exchanger 1a-o.

20
25

This type of heat exchanger 1a-o can be used in any industrial or domestic application that requires cooling, heating, air conditioning, or temperature regulation.

30

The present invention is not limited to the exemplary embodiments described, but extends to any modification or variation obvious to a person skilled in the art which remains within the scope of protection defined by the attached claims.

The claims defining the invention are as follows:

1. A heat exchanger comprising at least one group of at least two calorie- or frigorie-emitting thermal elements, each provided with at least one inlet orifice and at least one outlet orifice connected by at least one conduit traversing said thermal element
5 capable of receiving thermal fluid designed to recover said calories and/or said frigories, said heat exchanger comprising connection means designed to connect said conduits to one another and to at least one circuit external to said heat exchanger designed to utilize the calories and/or frigories recovered by said thermal fluid, wherein said connection
10 means comprises at least one interface plate placed flat against said thermal elements, comprising at least one channel equipped with connecting orifices facing the inlet orifices and outlet orifices in said thermal elements and defining at least one interface circuit allowing said thermal fluid to circulate between said thermal elements and said interface
15 plate through a series, parallel, or mixed connection, said interface plate also comprising at least one supply orifice and at least one discharge orifice which connect said interface circuit to said exterior circuit.

2. A heat exchanger according to claim 1, wherein said thermal elements alternately emit calories and frigories, and wherein said interface plate comprises at least two channels each equipped with at least one supply orifice, one discharge orifice, and
20 connecting orifices defining two distinct interface circuits connected to two external circuits.

3. A heat exchanger according to claim 1, wherein it comprises at least two groups of thermal elements each provided with at least one interface plate and complementary connection means for connecting said interface plates to one another and
25 the interface circuits of said corresponding groups in a series, parallel, or mixed connection.

4. A heat exchanger according to claim 1, wherein said connection means comprises at least two interface plates superimposed back to back, each comprising at least one channel, one supply orifice, one discharge orifice, and connecting orifices
30 connected to a unit of thermal elements.

5. A heat exchanger according to claim 4, wherein said interface plates comprise traversing orifices facing each other to define a common interface circuit.

6. A heat exchanger according to claim 1, wherein said channel is at least partially formed of a network of perforations through the wall of said interface plate

selectively blocked by plugs depending upon the function of the interface circuit to be formed.

7. A heat exchanger according to claim 1, wherein said channel is at least partially formed by one or more grooves located on at least one surface of said interface plate.

8. A heat exchanger according to claim 7, wherein said grooves are formed by machining, engraving, or casting.

9. A heat exchanger according to claim 7, wherein said connection means comprise at least one closing plate superimposed on said interface plate on the grooved side to form said channel.

10. A heat exchanger according to claims 5 and 9, wherein said closing plate is located between two interface plates to form with each one said channel.

11. A heat exchanger according to claim 10, wherein said closing plate comprises traversing orifices opening into said channels in order to connect them in a series, parallel, or mixed connection.

12. A heat exchanger according to claim 11, wherein said closing plate comprises a switch movable between at least two positions so as to modify the mode of connection between said interface circuits.

13. A heat exchanger according to claim 12, wherein said switch is chosen from the group comprising at least a slide block, a core, or a sliding unit and it is controlled by a driving mechanism.

14. A heat exchanger according to claim 1, wherein said connection means comprises sealing elements located at least between said thermal elements and said interface plate.

15. A heat exchanger according to claim 14, wherein said sealing means are selected from the group comprising a coating, a Teflon sheet, or a liquid seal.

16. A heat exchanger according to claim 1, wherein said connection means is at least partially made of a thermally insulating material.

17. A heat exchanger substantially as hereinbefore described with reference to any one of the embodiments as that embodiment is shown in the accompanying drawings.

Dated 4 December 2009

Cooltech Applications S.A.S.

Patent Attorneys for the Applicant/Nominated Person

SPRUSON & FERGUSON

FIG. 1A

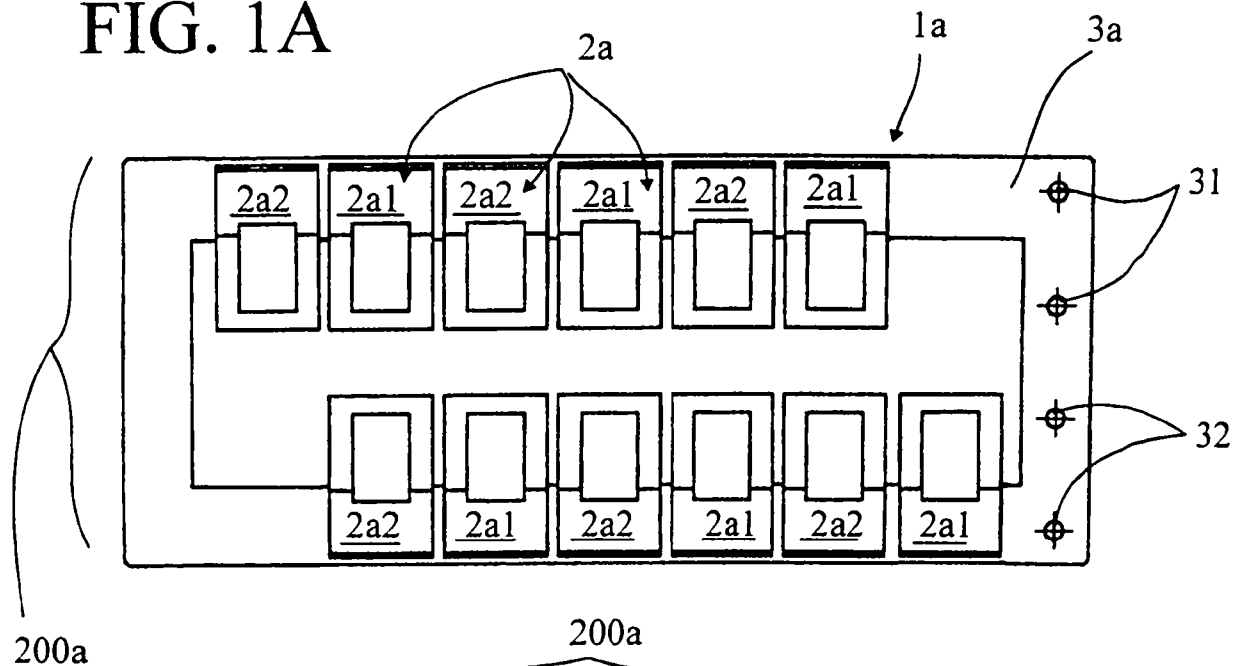

FIG. 1B

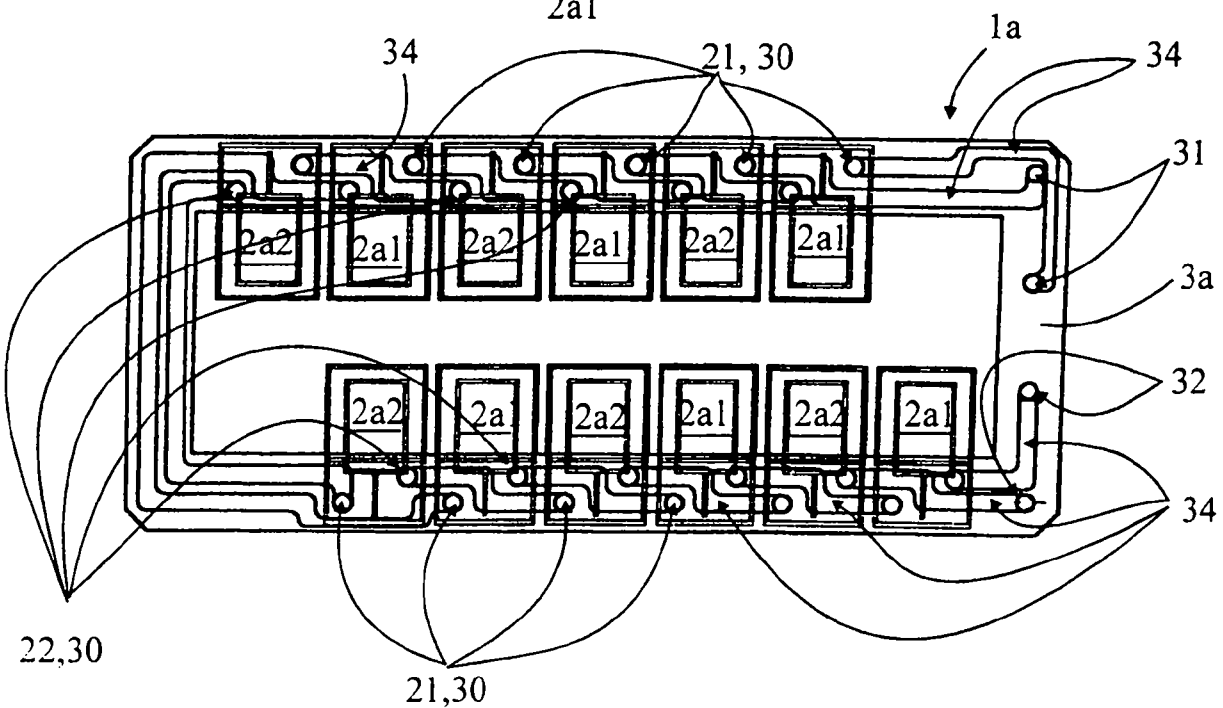
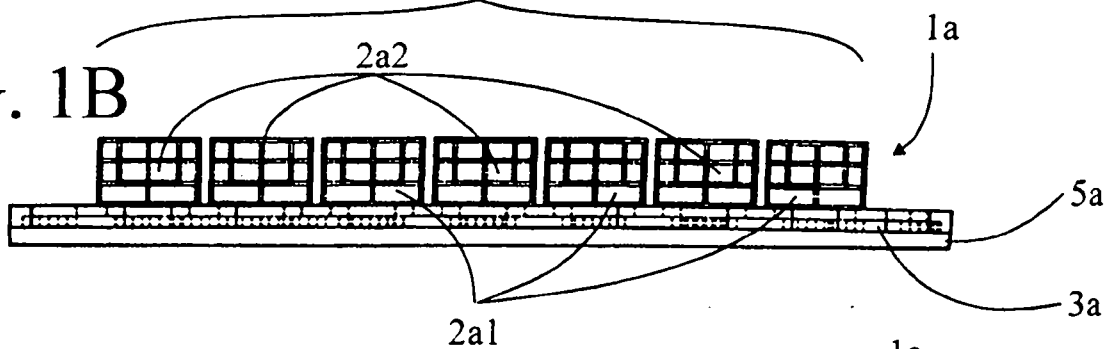

FIG. 1C

FIG. 1D

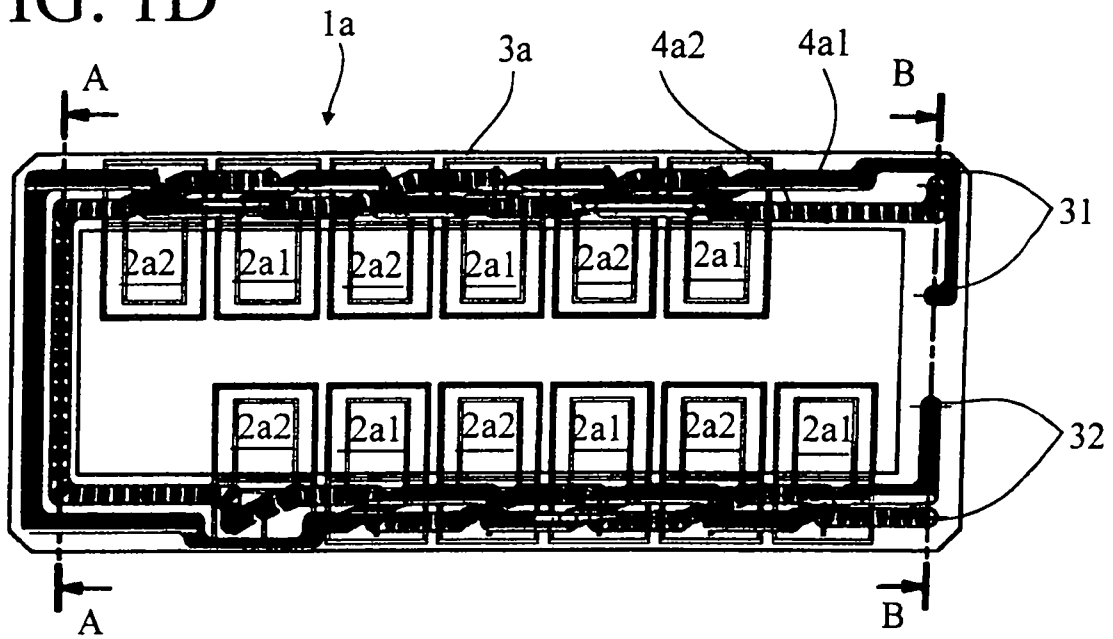

FIG. 1E



FIG. 1F

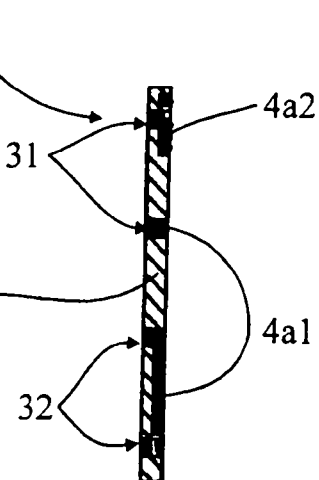

FIG. 1G

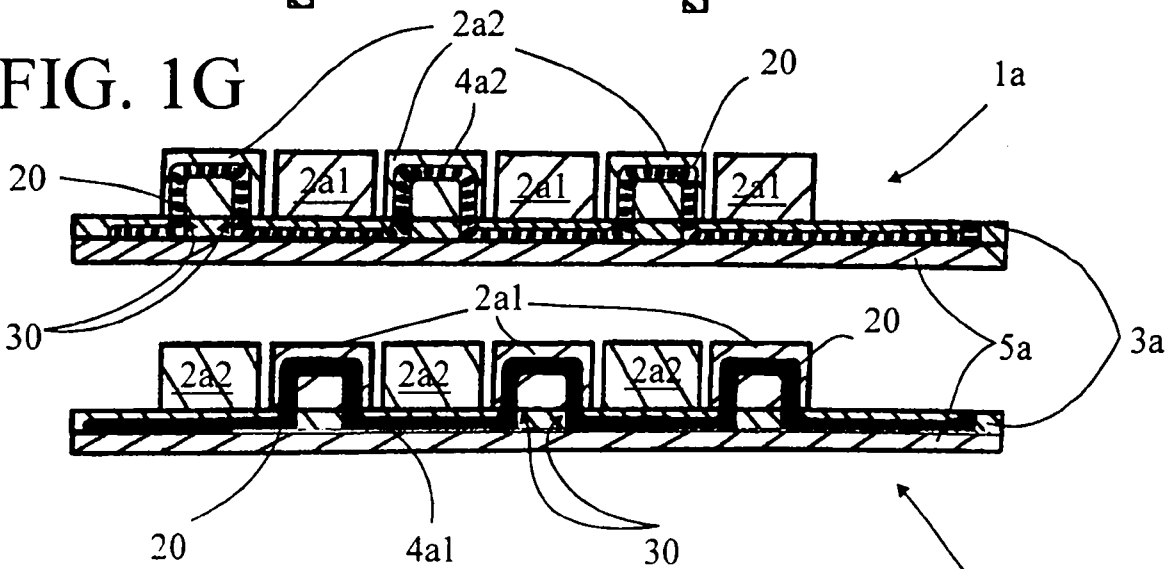

FIG. 1H

1a

FIG. 1I

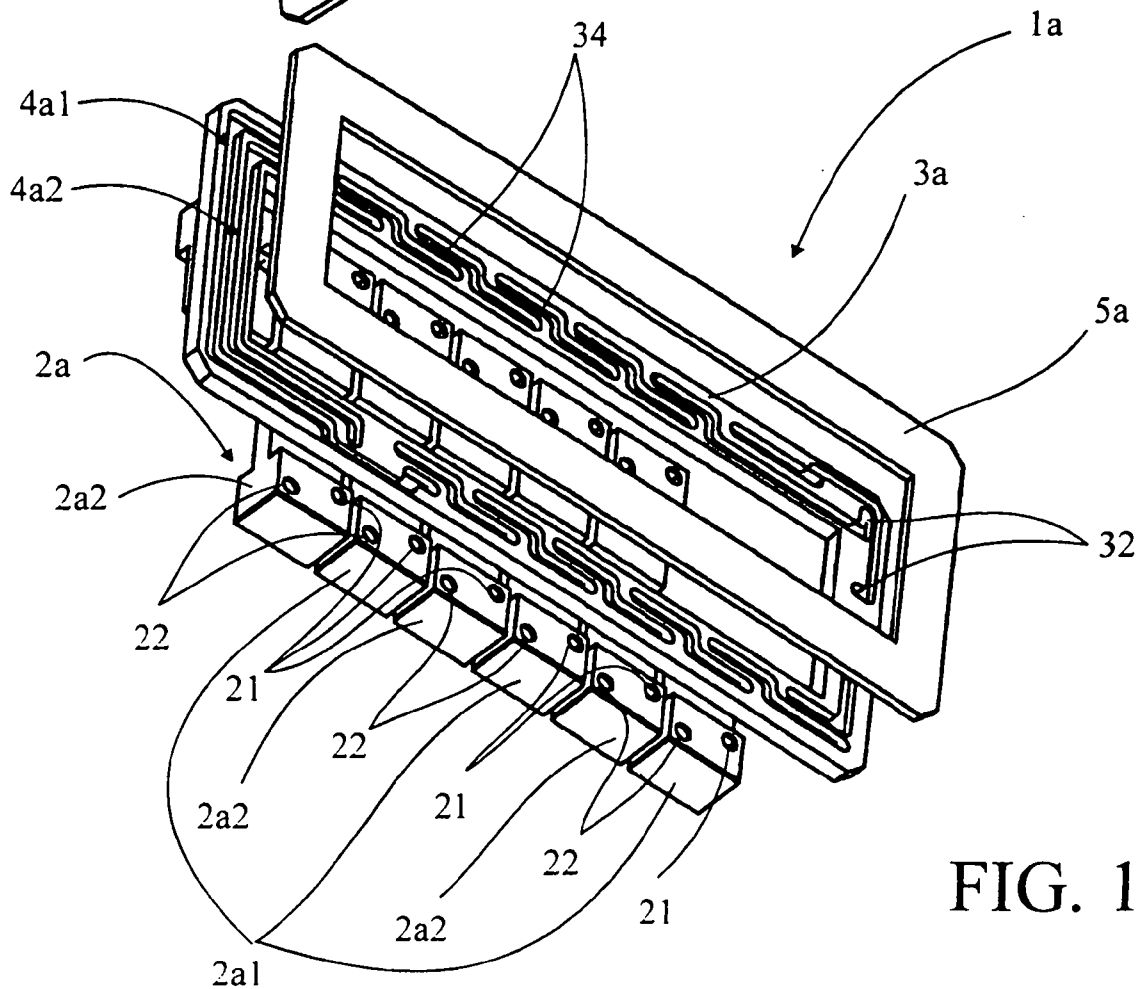
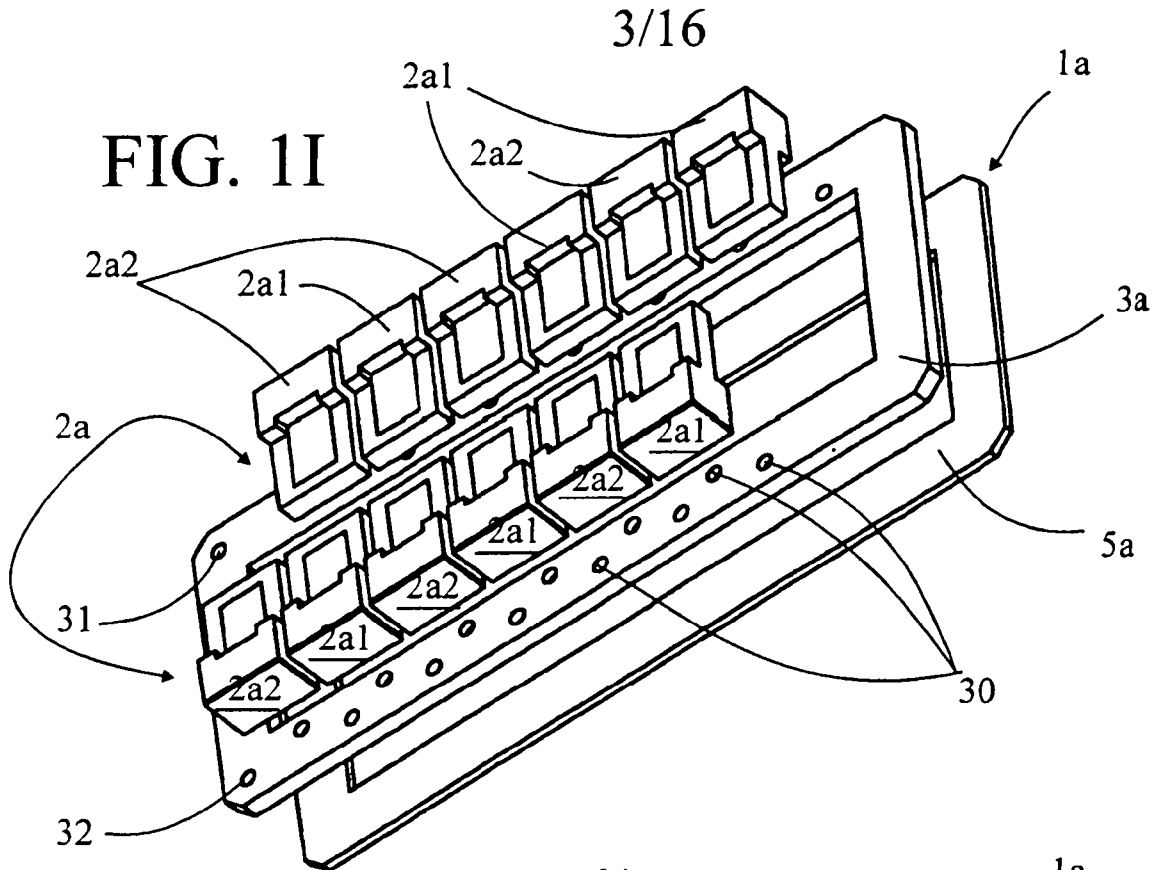

FIG. 1J

FIG. 2A

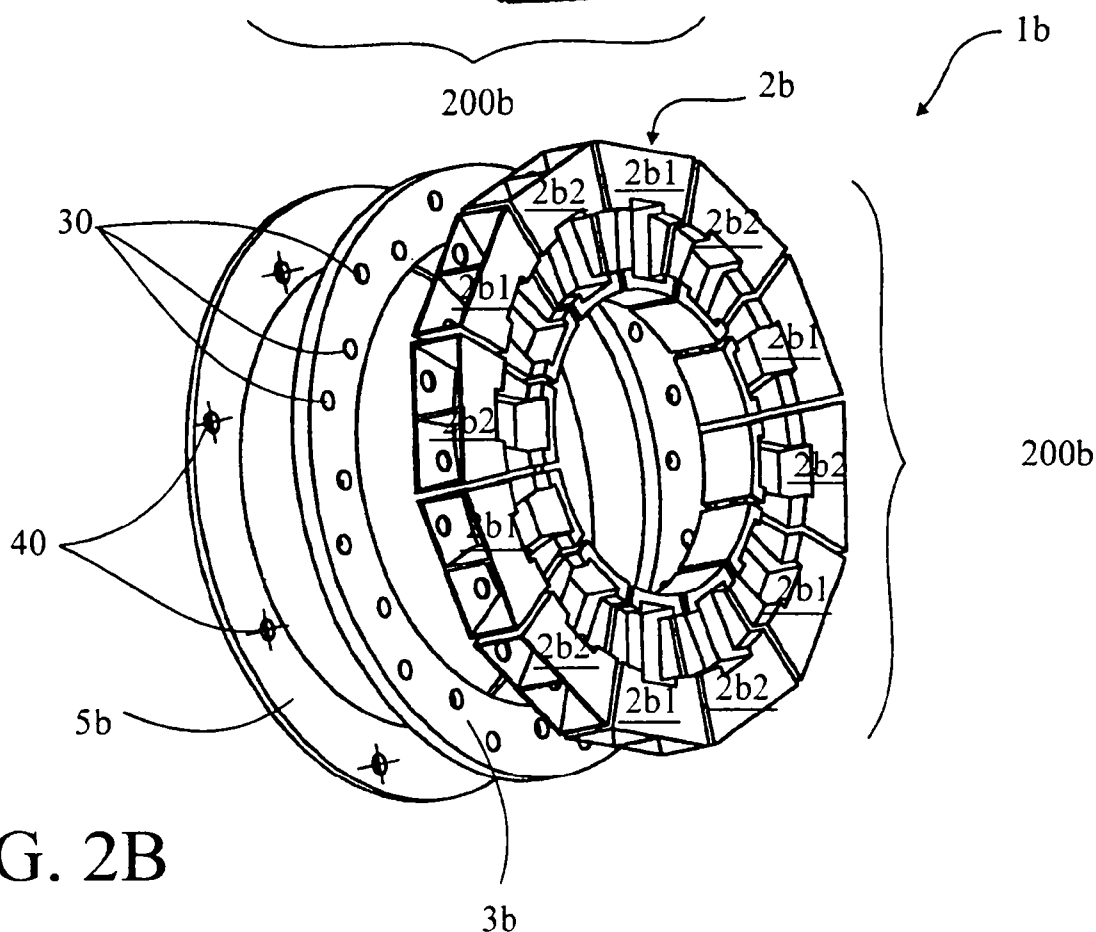
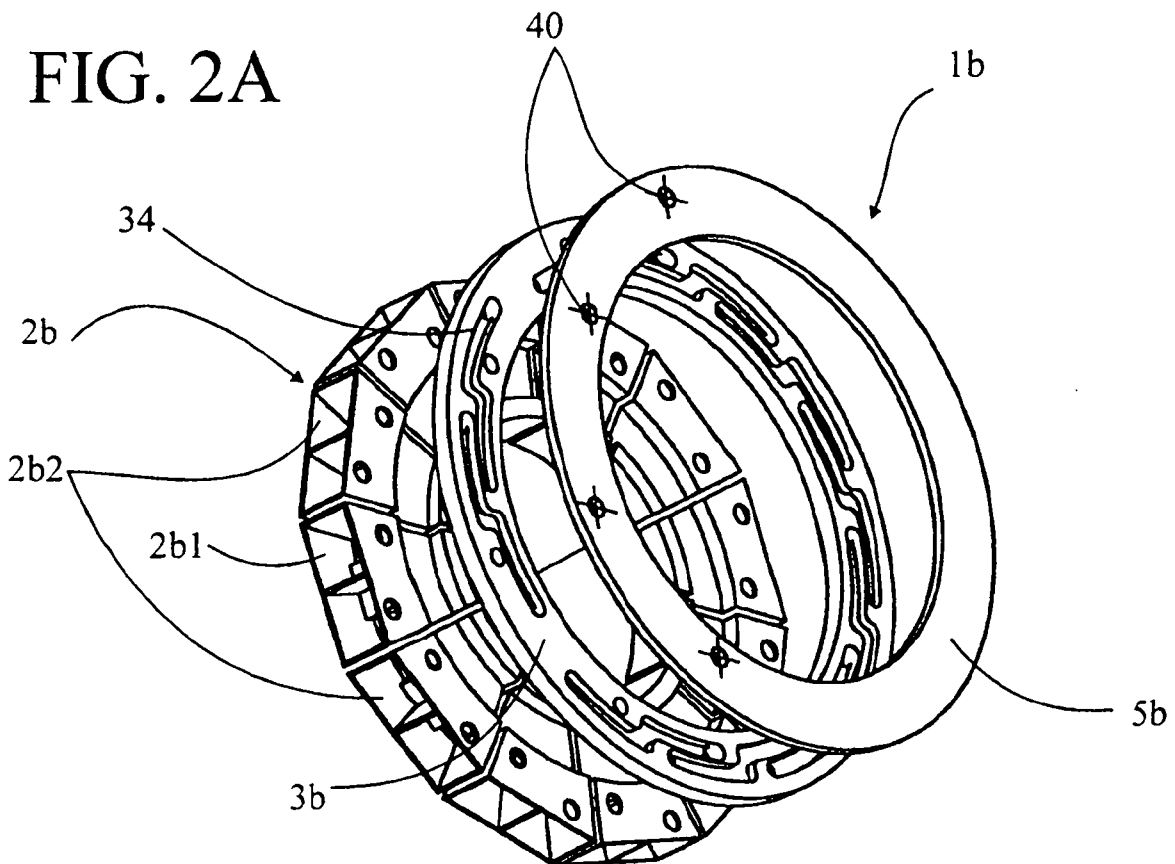

FIG. 2B

FIG. 2C

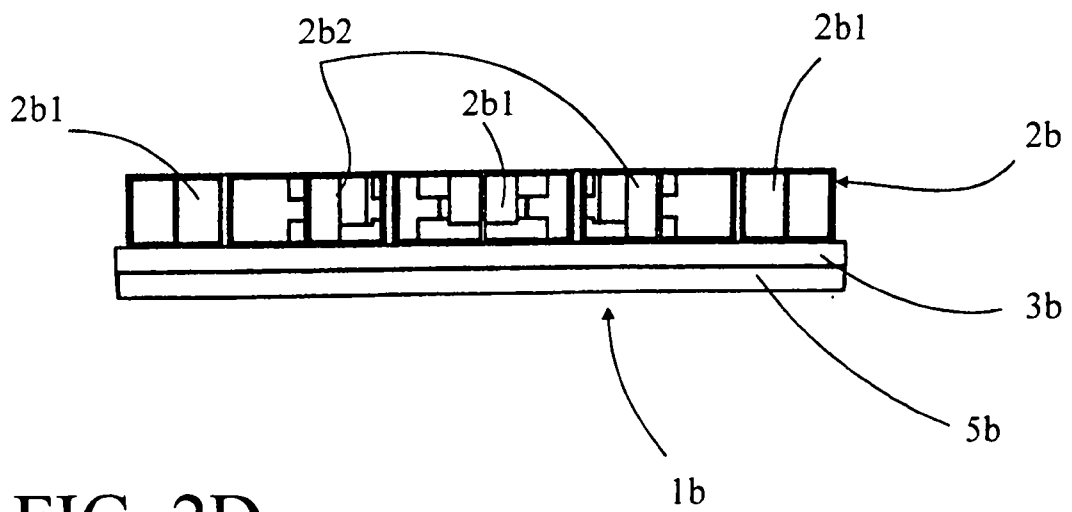
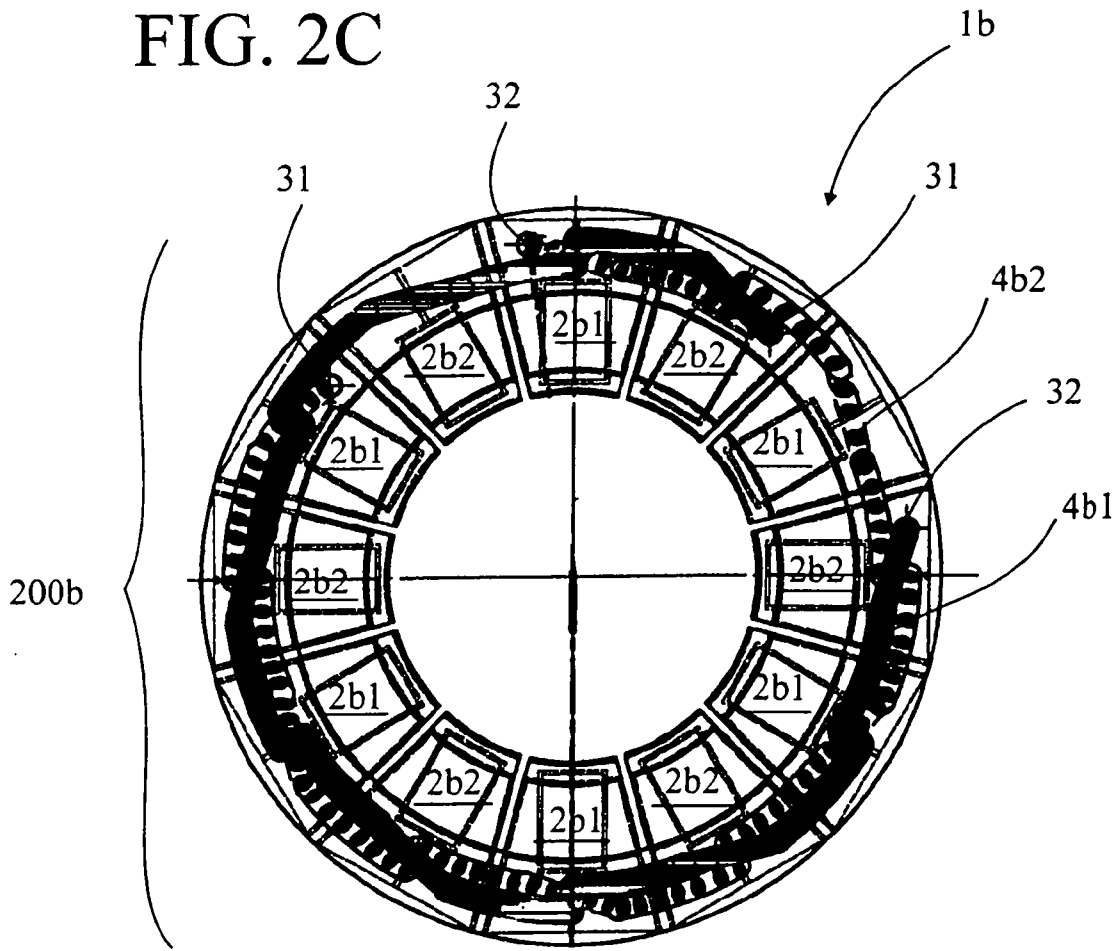

FIG. 2D

FIG. 3C

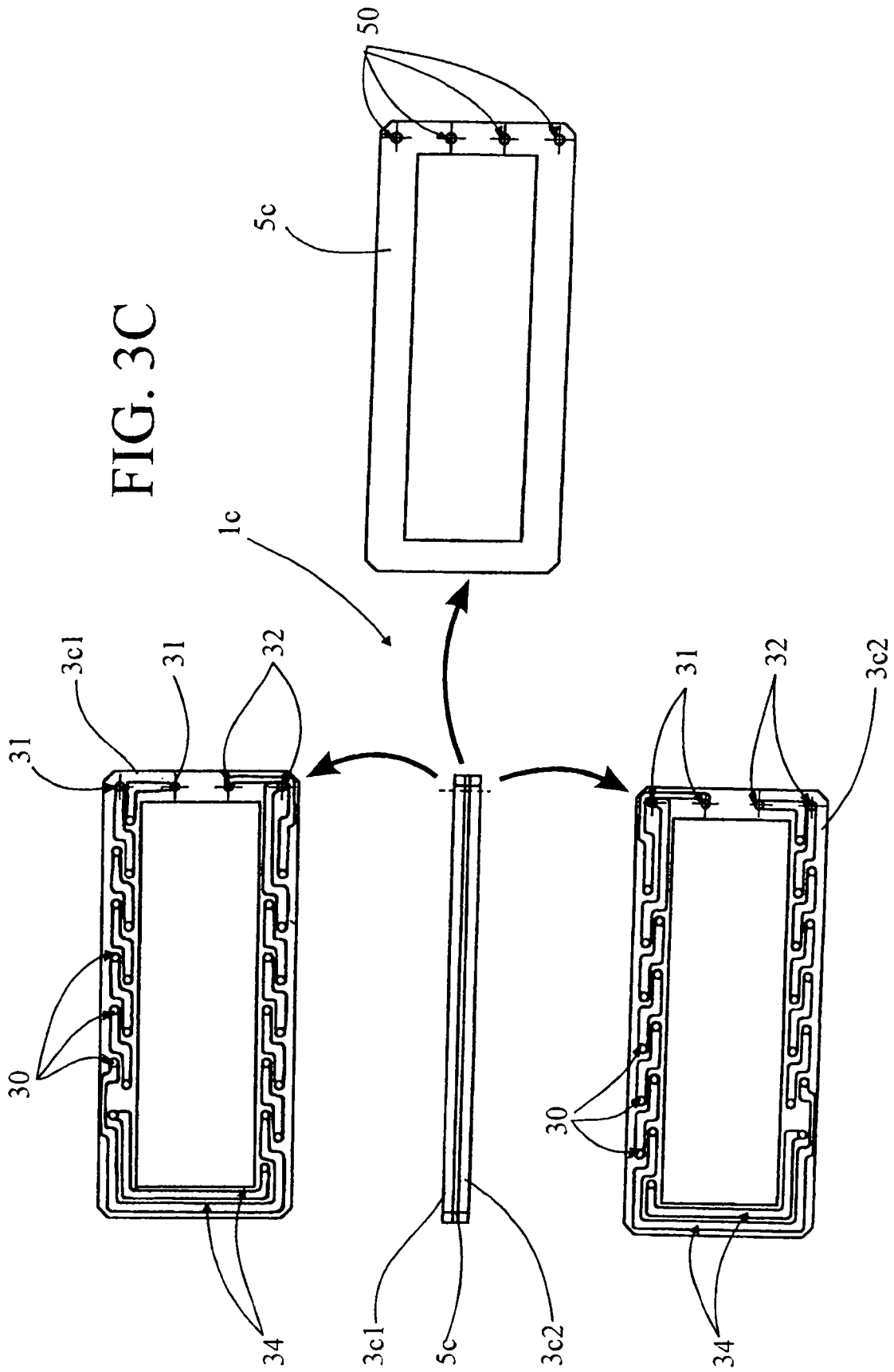

FIG. 3D

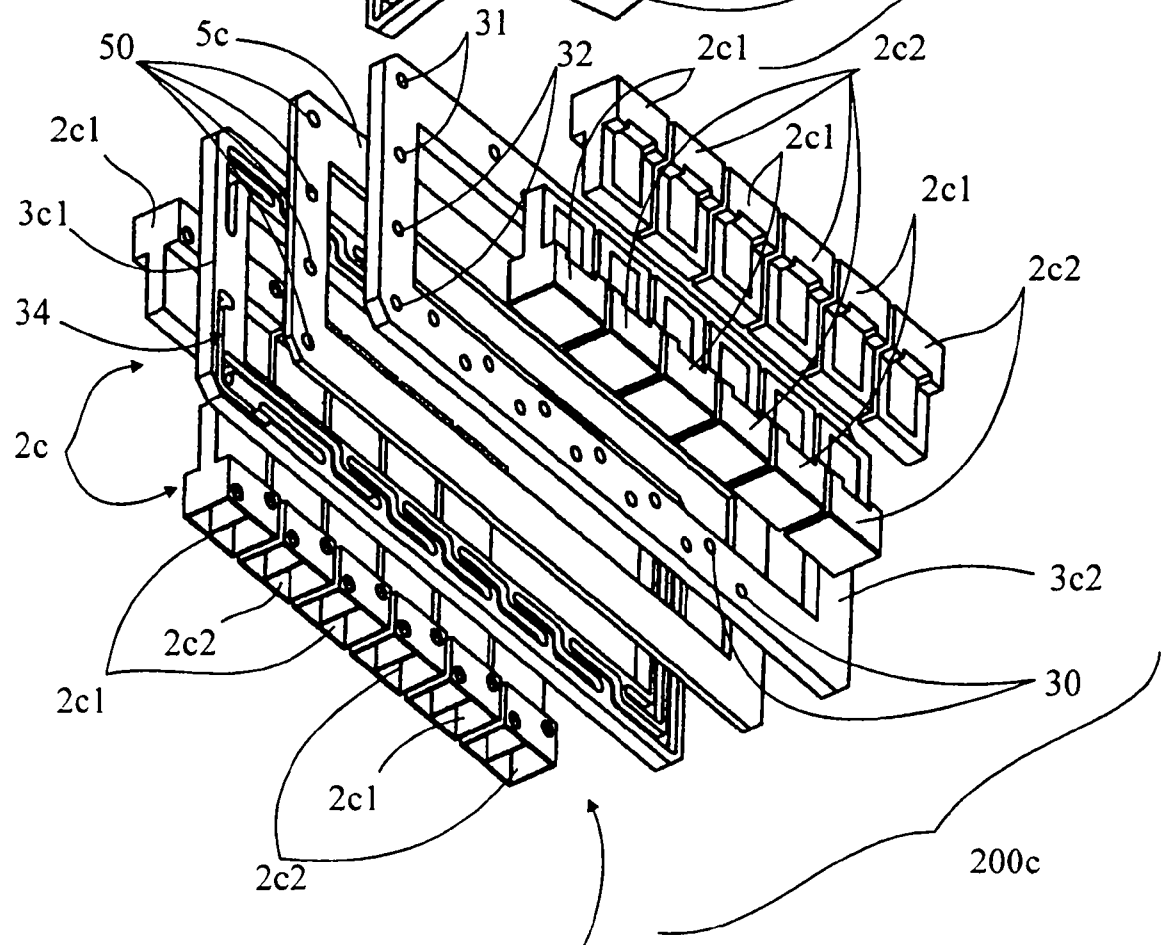
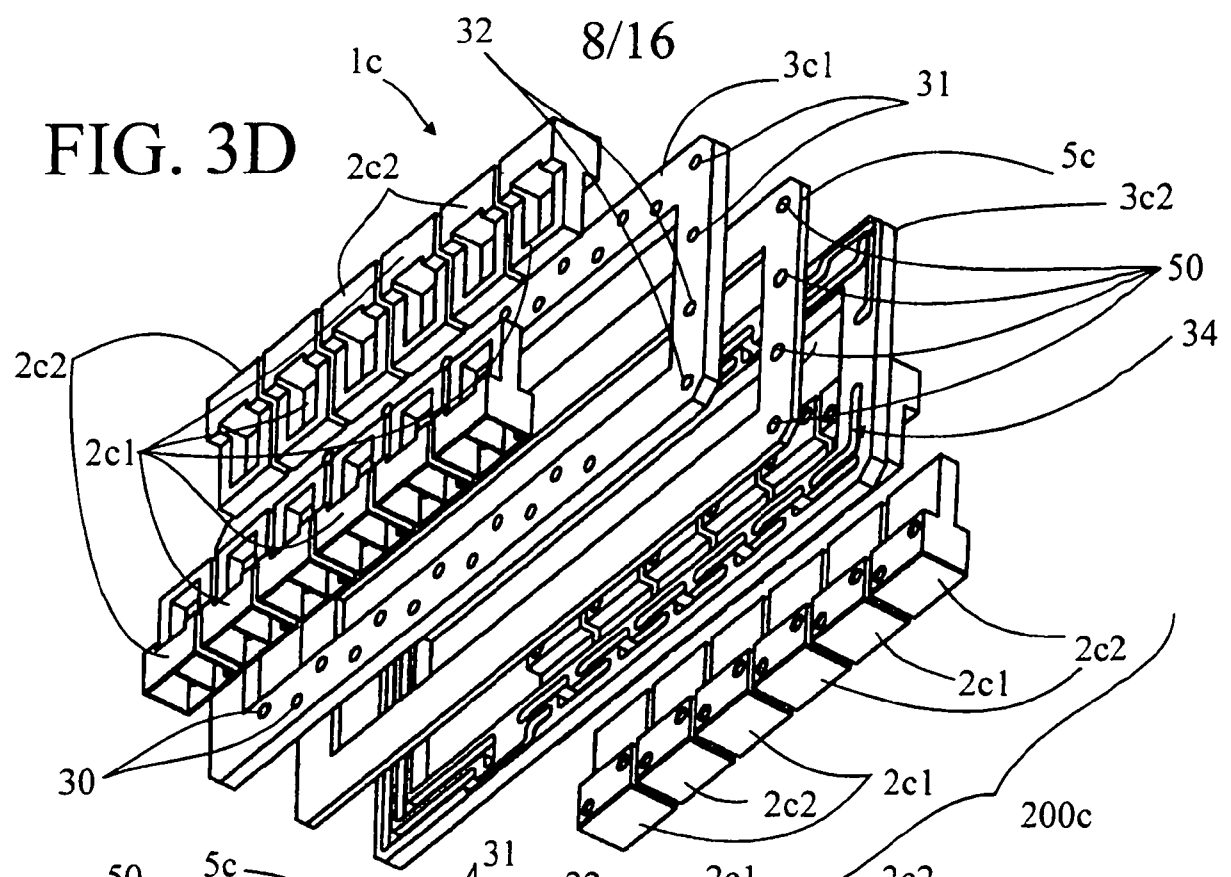

FIG. 3E

1c

9/16

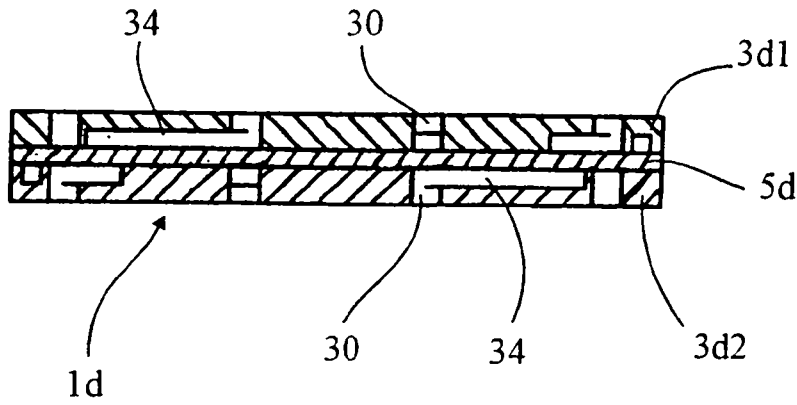

FIG. 4A

FIG. 4B

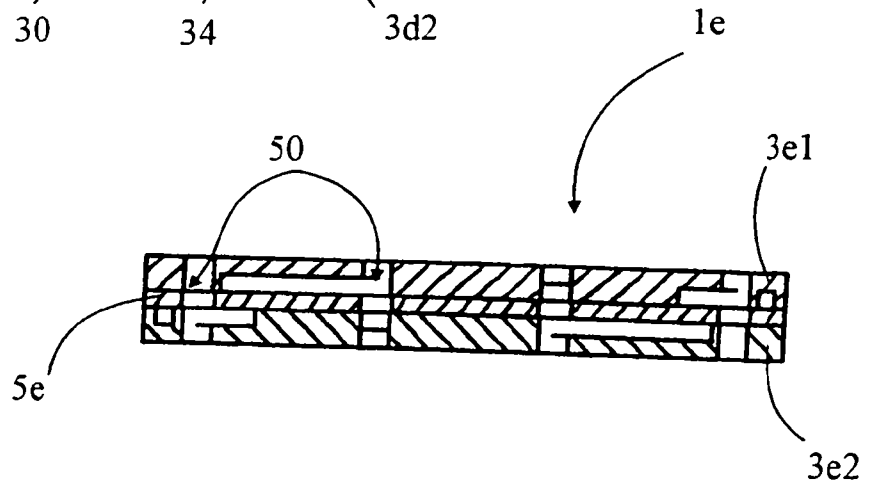

FIG. 4C

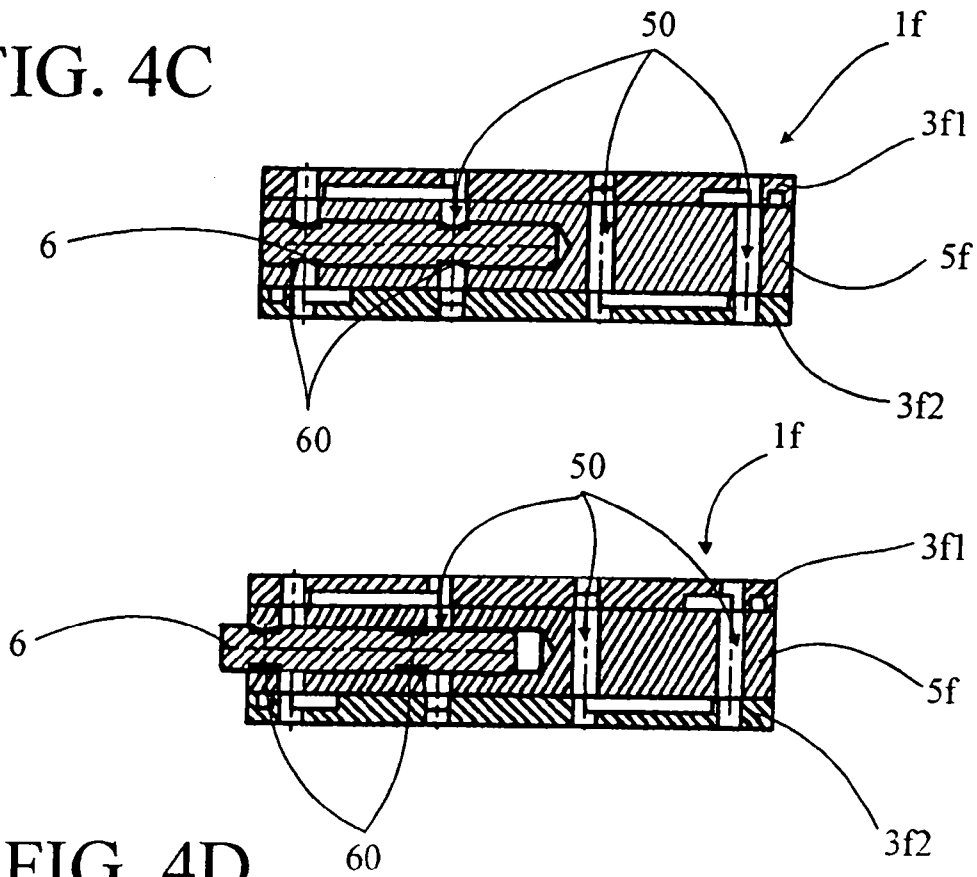

FIG. 4D

FIG. 5A

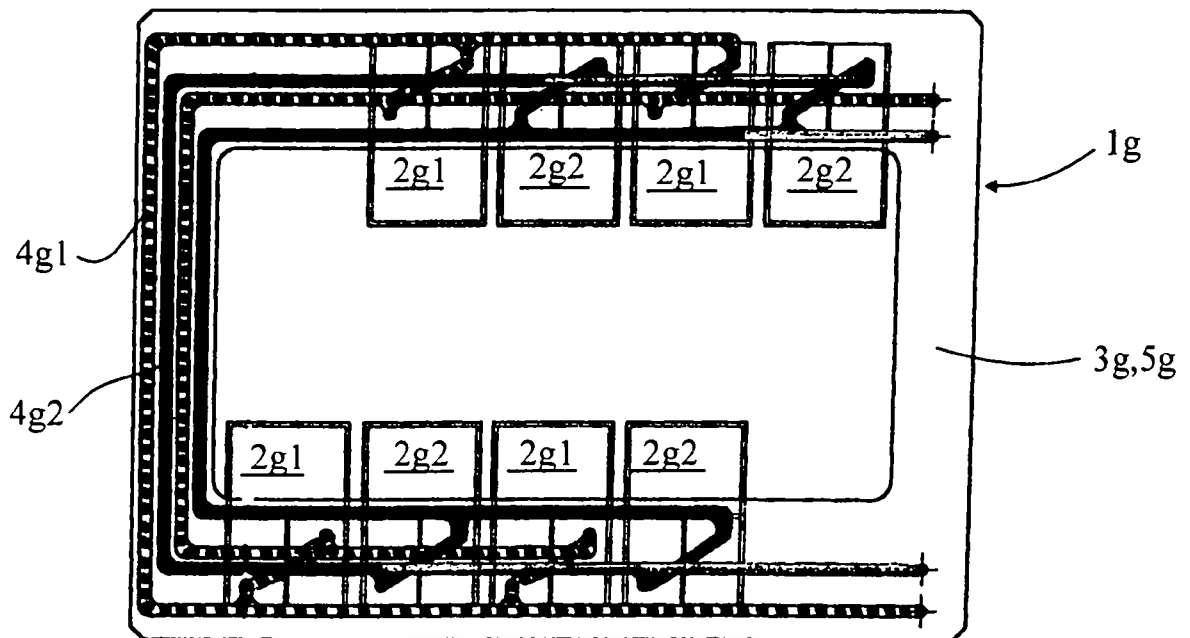
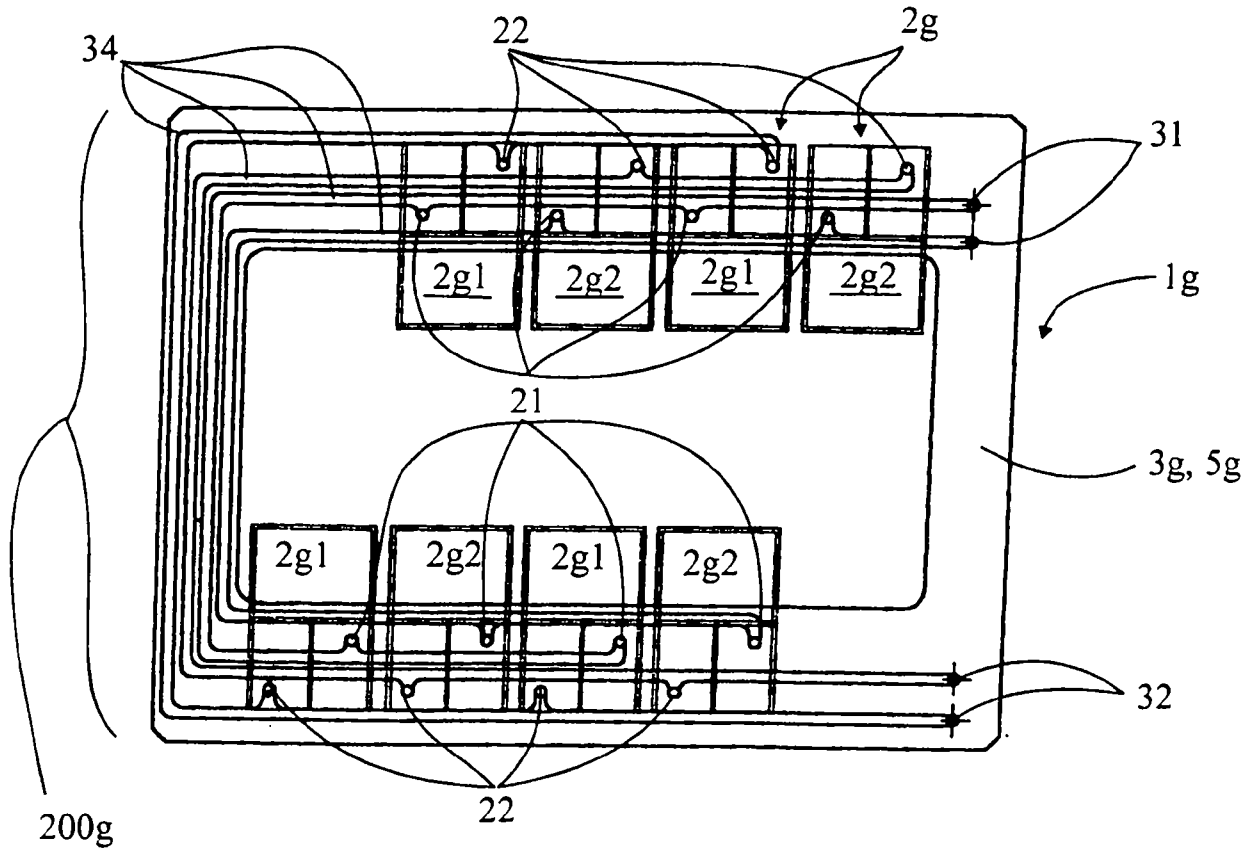

FIG. 5B

FIG. 6A

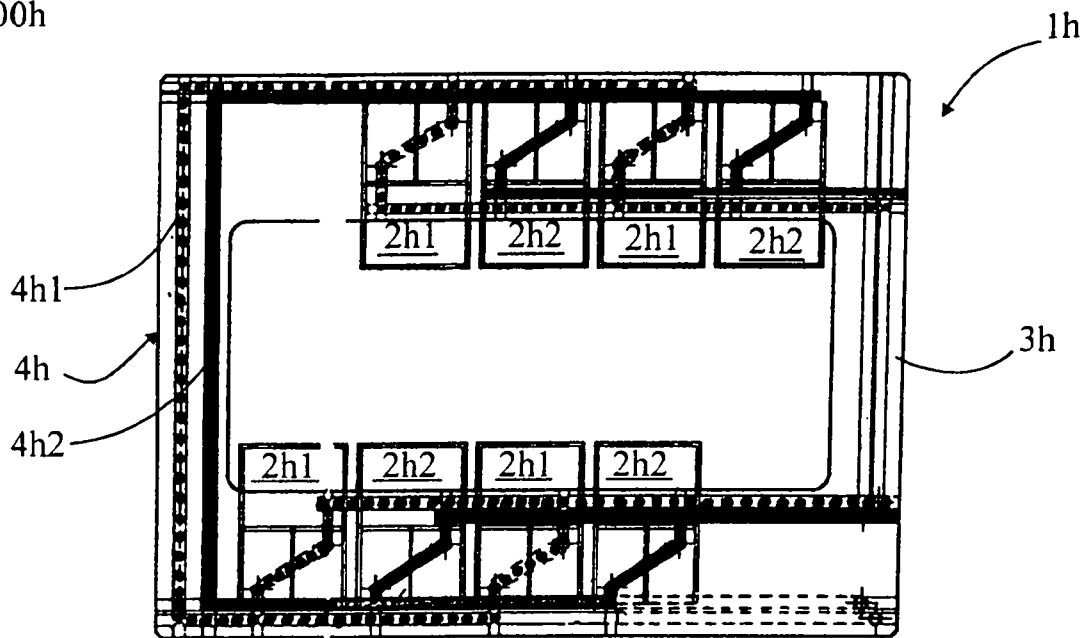
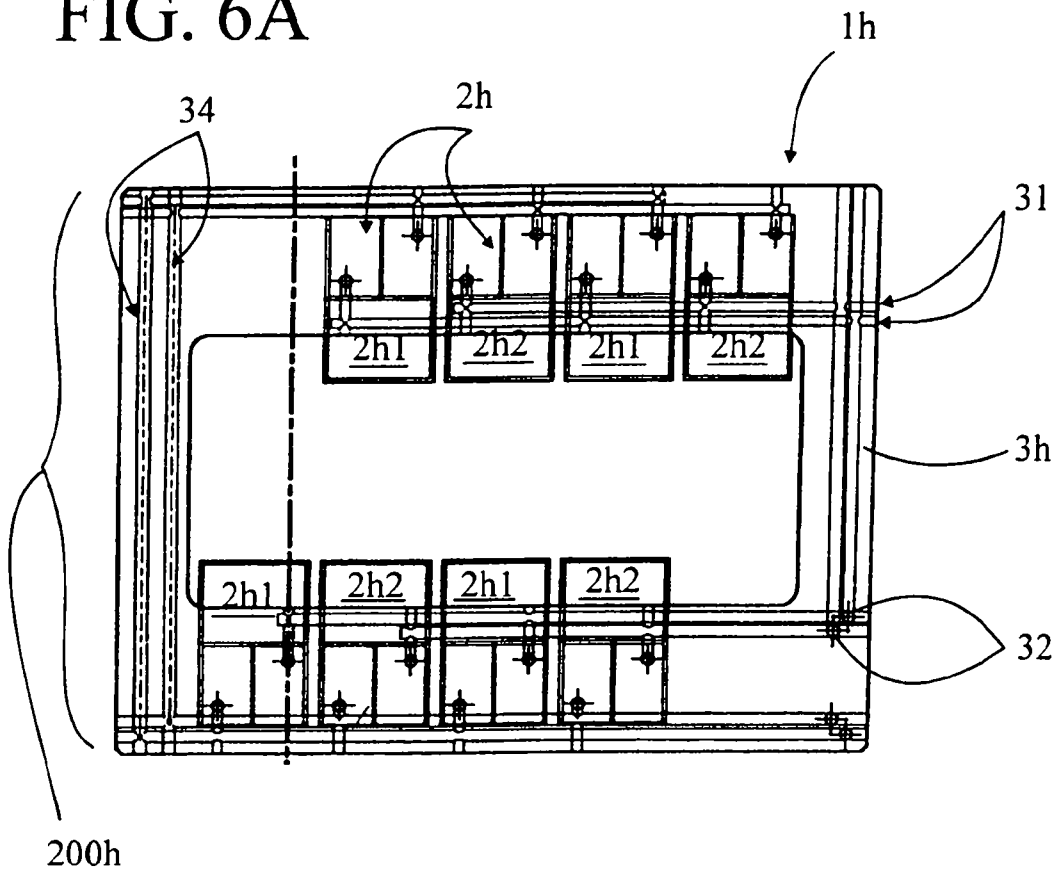

FIG. 6B

FIG. 7A

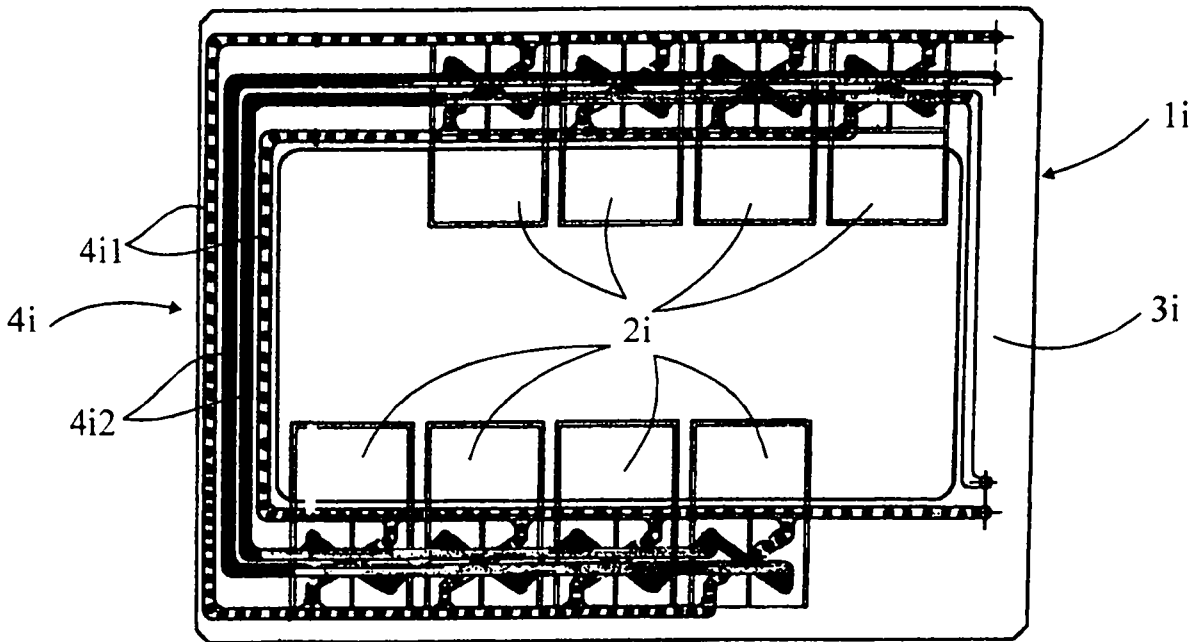
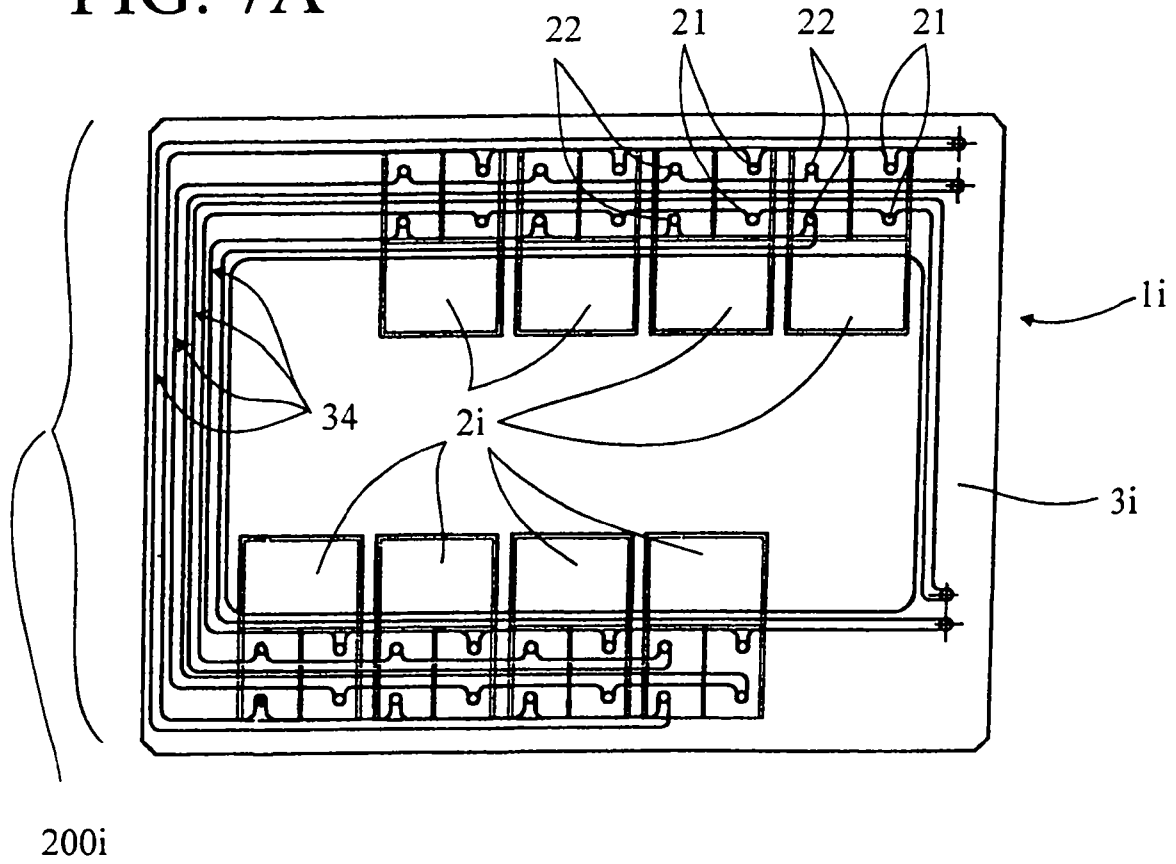

FIG. 7B

FIG. 8A

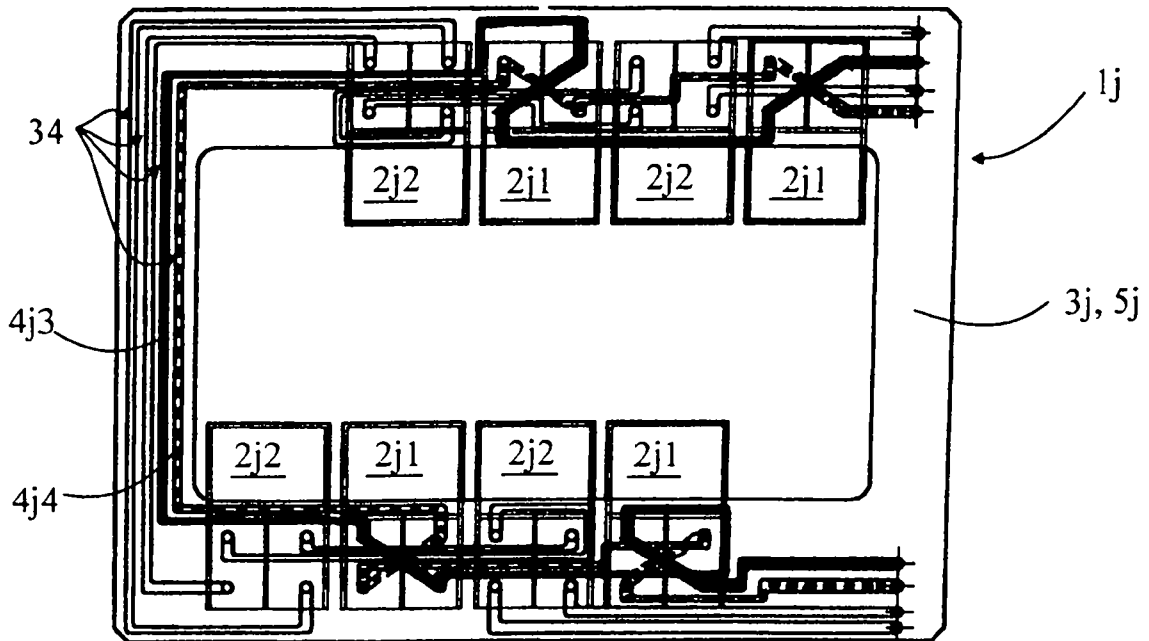
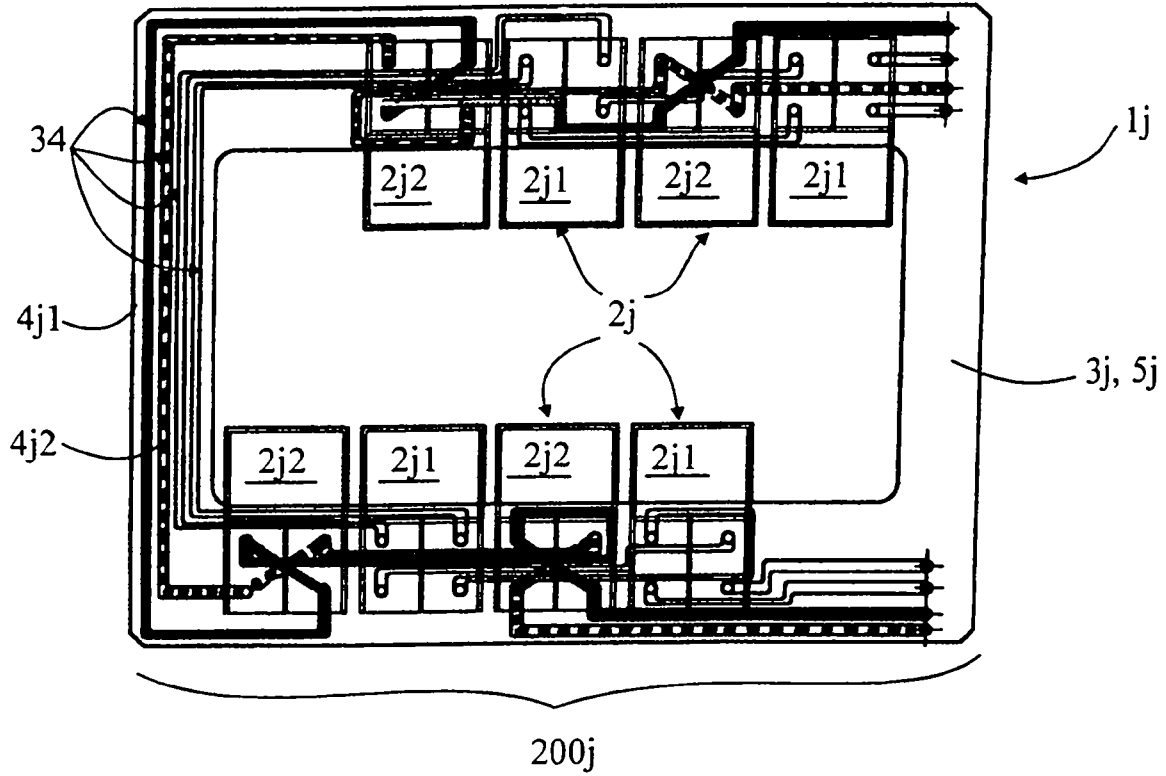

FIG. 8B

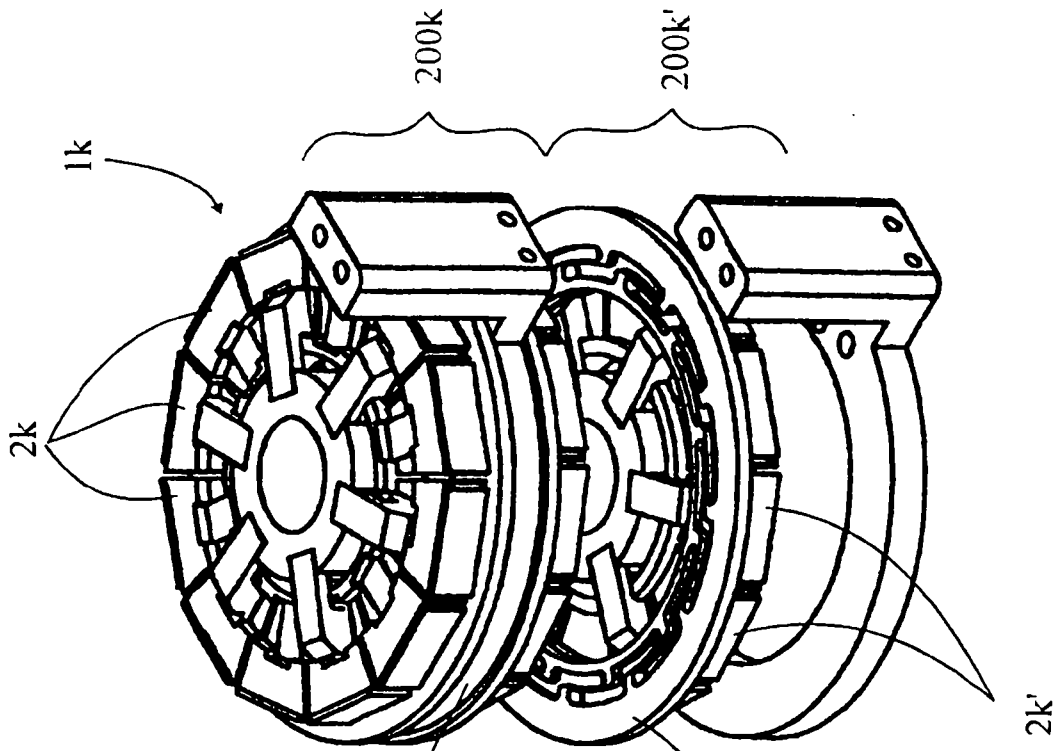

FIG. 9A

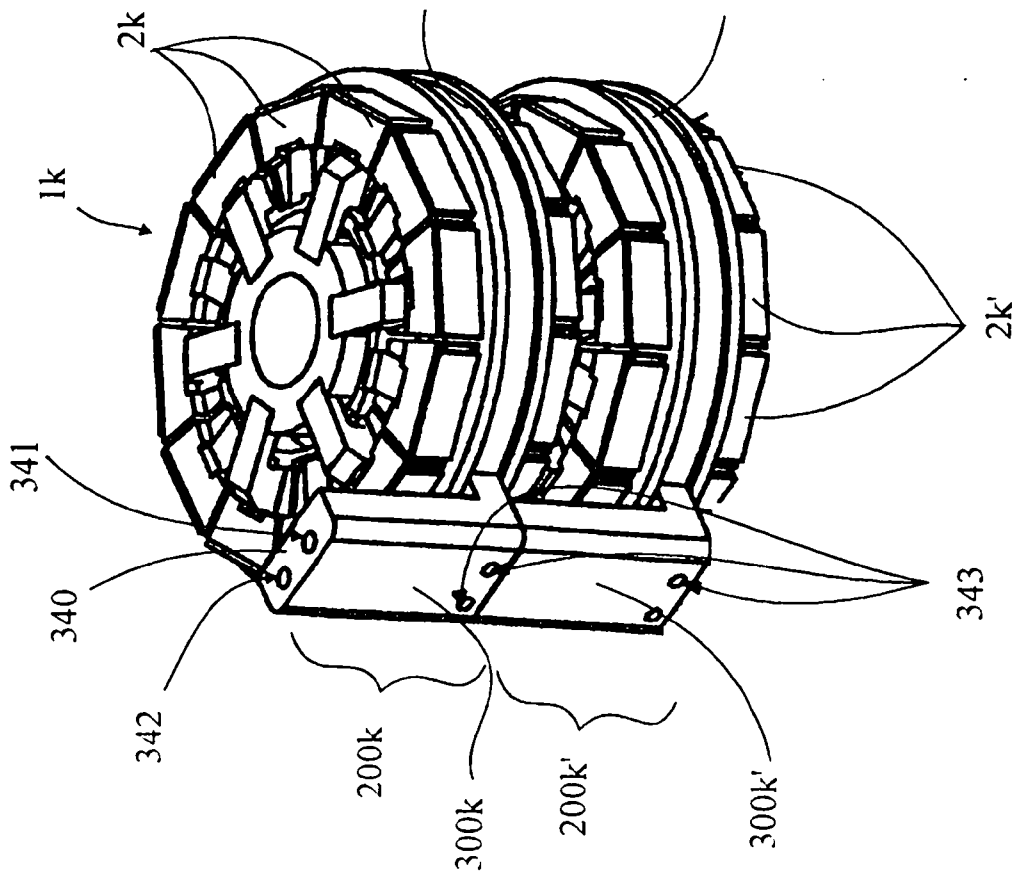

FIG. 9B

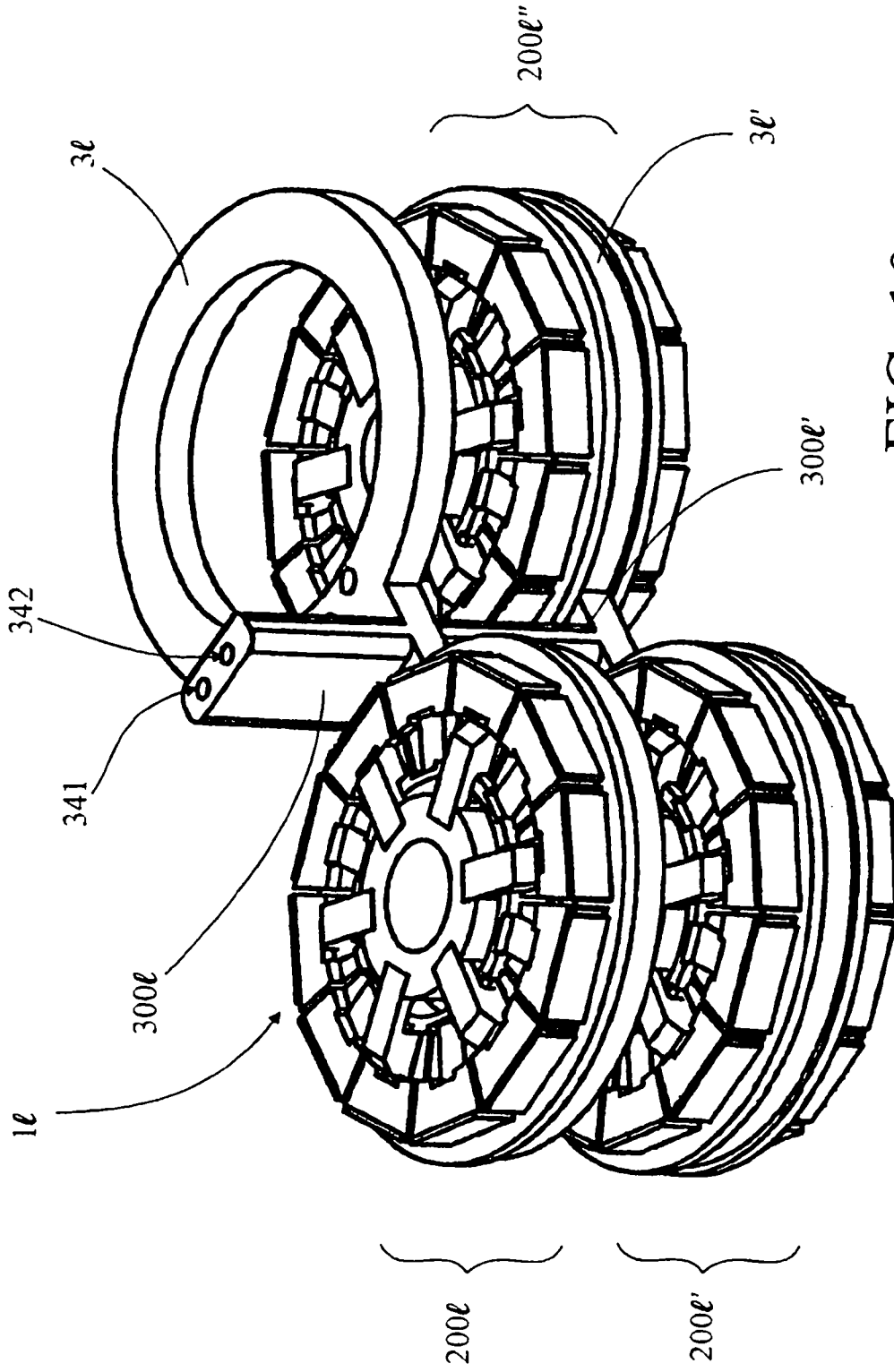

FIG. 10

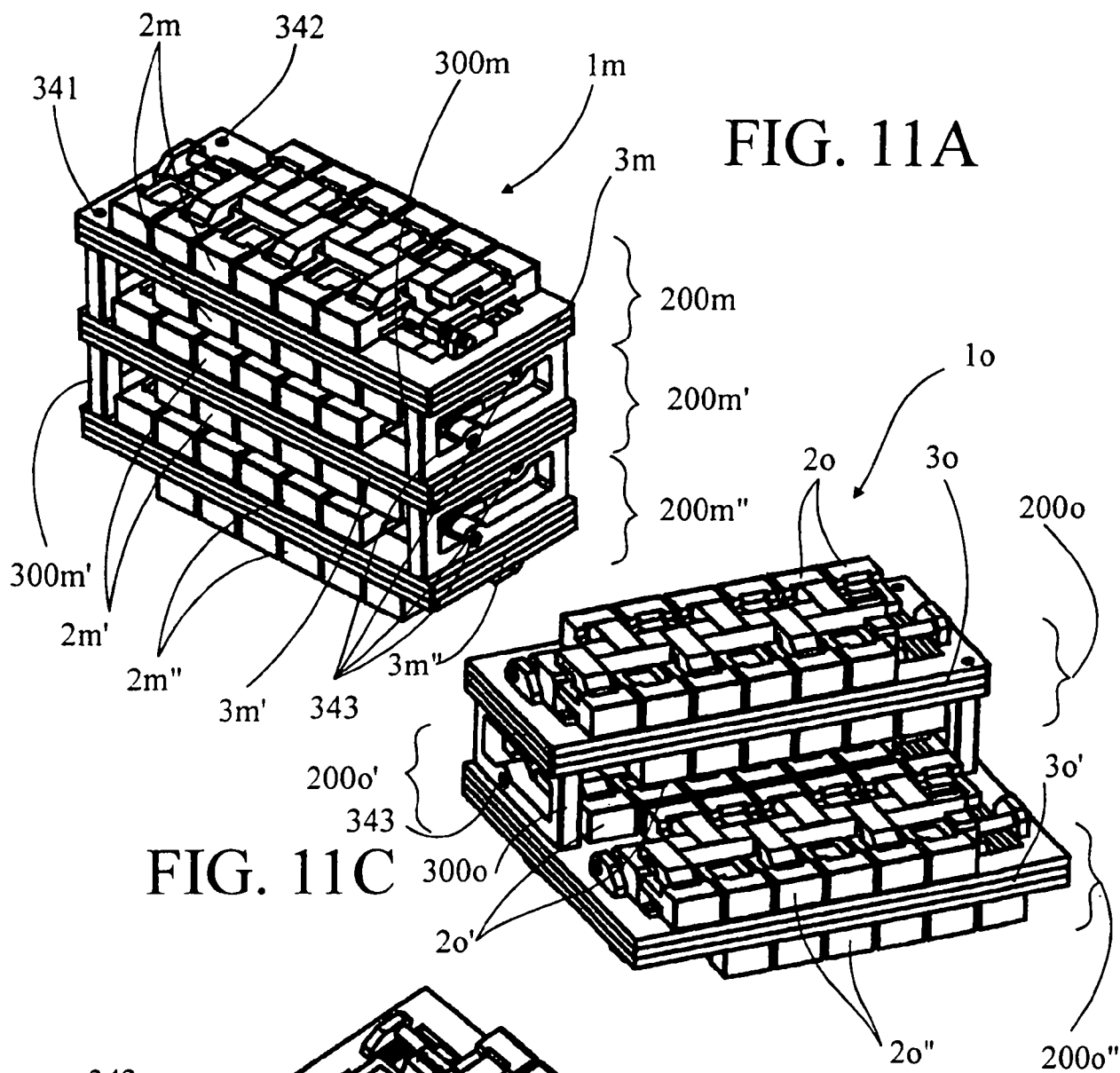

FIG. 11A

FIG. 11C

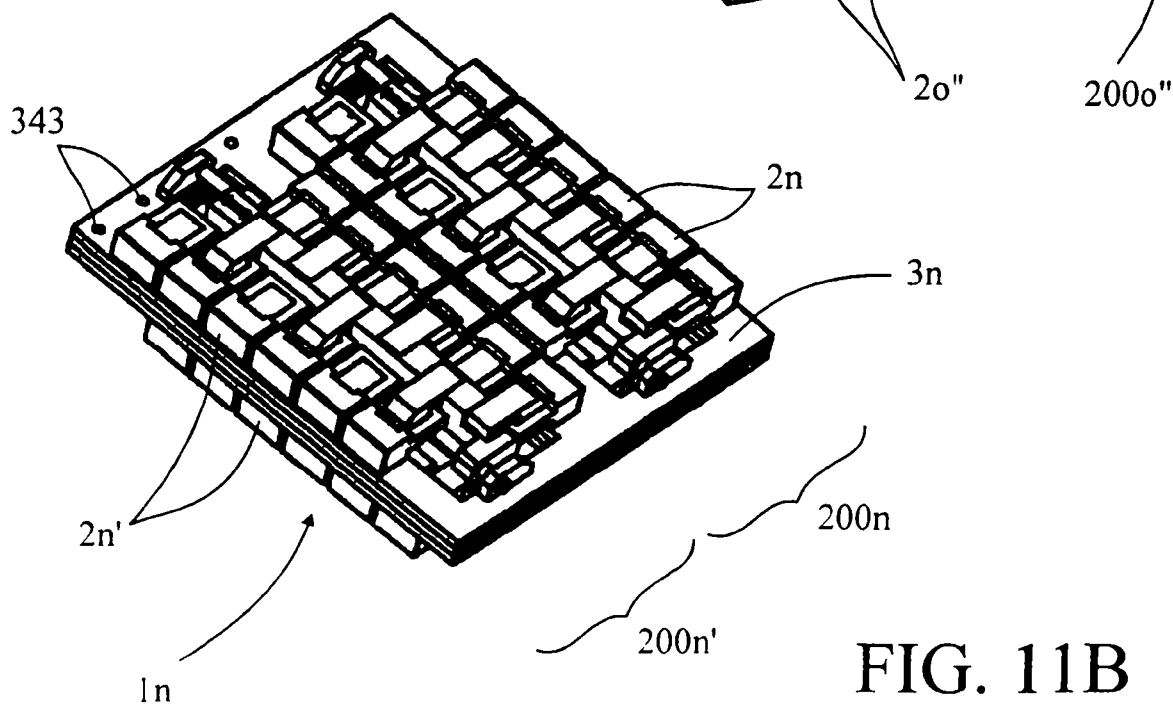

FIG. 11B