

(No Model.)

3 Sheets—Sheet 1.

W. A. SHAW.  
REACTIONARY GAS MOTOR ENGINE.

No. 523,734.

Patented July 31, 1894.

*Fig. 1.*

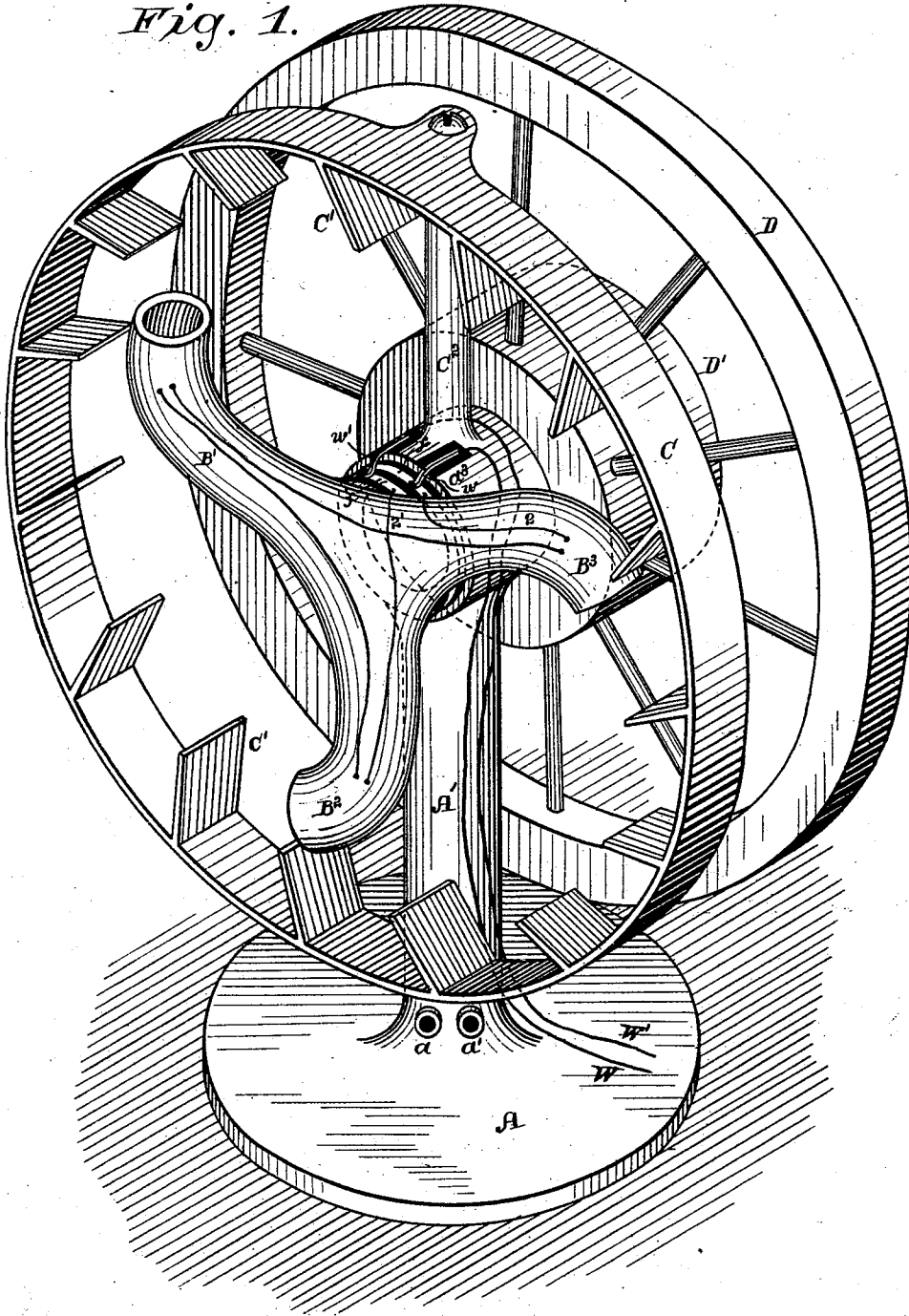

WITNESSES

*E. Q. Newman*  
*C. M. Newman*

INVENTOR

*Wm. A. Shaw,*

*By his Attorneys*

*Baldwin Hopkins & Peyton*

W. A. SHAW.  
REACTIONARY GAS MOTOR ENGINE.

No. 523,734.

Patented July 31, 1894.

Fig. 2.

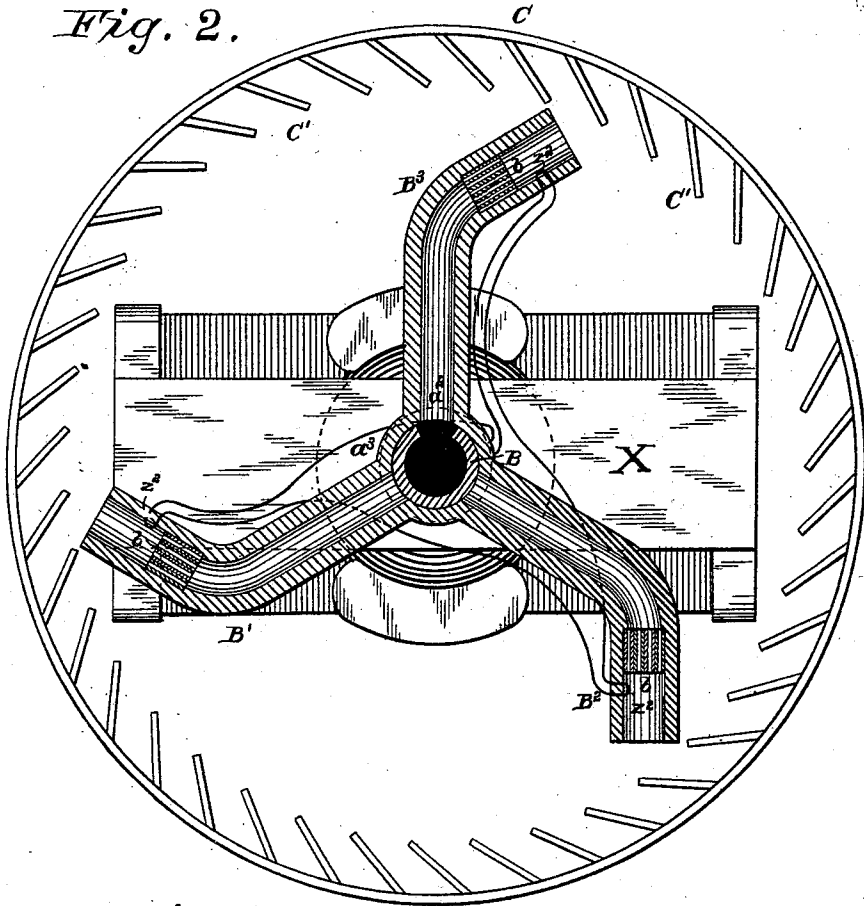
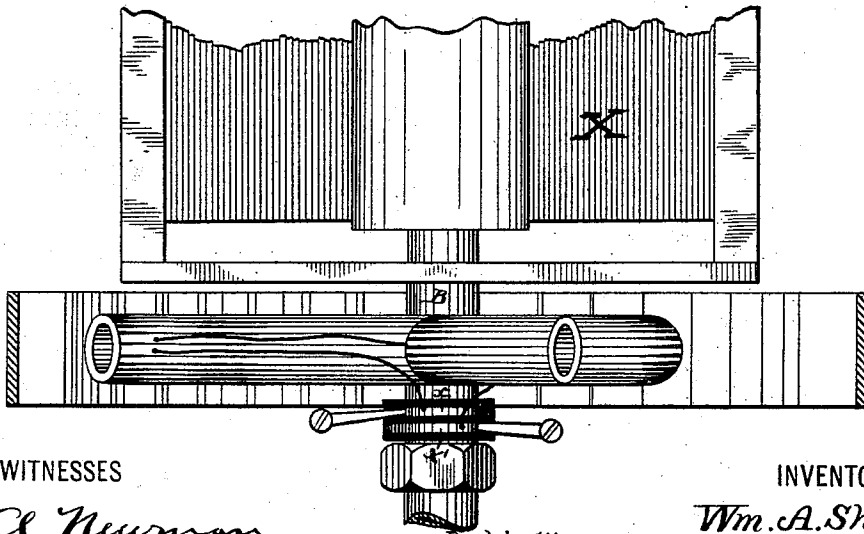

Fig. 3.



WITNESSES

*E. A. Newman,*  
*C. M. Newman,*

INVENTOR

*Wm. A. Shaw*

By his Attorneys

*Baldwin Hopkins & Raybin*

W. A. SHAW.  
REACTIONARY GAS MOTOR ENGINE.

No. 523,734.

Patented July 31, 1894..

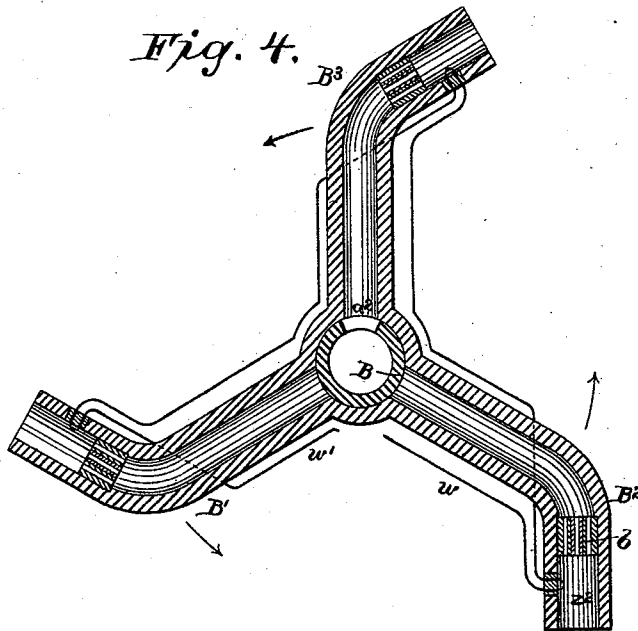
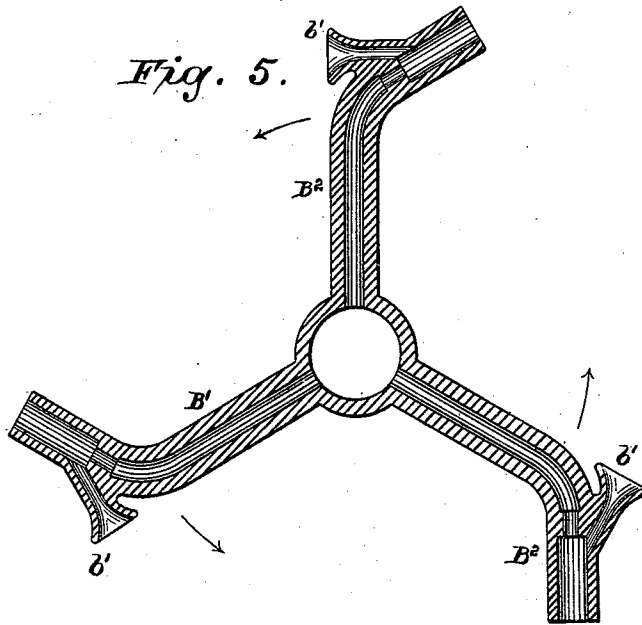

WITNESSES

*E. A. Newman*  
*C. M. Newman,*

INVENTOR

*Wm. A. Shaw*  
By his Attorneys  
*Baldwin Hopkins & Peyton*

# UNITED STATES PATENT OFFICE.

WILLIAM ANTHONY SHAW, OF PITTSBURG, PENNSYLVANIA.

## REACTIONARY GAS-MOTOR ENGINE.

SPECIFICATION forming part of Letters Patent No. 523,734, dated July 31, 1894.

Application filed October 7, 1887, Serial No. 251,754. (No model.)

*To all whom it may concern:*

Be it known that I, WILLIAM ANTHONY SHAW, a citizen of the United States, residing at Pittsburg, in the county of Allegheny and State of Pennsylvania, have invented certain new and useful Improvements in Reactionary Gas-Motor Engines, of which the following is a specification.

My invention relates to that class of engines or motors driven by combustion or explosion of the gas. Its object is to obtain an economical, durable machine, simple in construction, effective in operation, and comparatively free from liability to derangement or wear. These ends I attain by a novel organization of apparatus embracing the adaptation of the well known Barker mill or reactionary wheel to operation as a gas-engine in which the gas is ignited by a current of electricity. The subject-matter claimed will hereinafter specifically be designated in the claims at the end of this specification.

The accompanying drawings show all the improvements herein claimed embodied in one machine in the best way now known to me; some of said improvements may, however, be used without the others, and in machines varying somewhat in the details of their construction from those herein shown.

Figure 1 represents a view in perspective of so much of one form of the machine as is necessary to illustrate the invention; Fig. 2, a central longitudinal section therethrough; Fig. 3, a plan with the encircling rim or abutment band in section, showing more particularly the electrical circuit-connections of the igniting apparatus; Fig. 4, a central longitudinal section through the reactionary arms; and Fig. 5, a similar view of a modified form of the same.

The mechanism is shown as mounted on a strong base or frame, firmly secured in position in well-known ways. The frame is shown in this instance as consisting of a broad flat base A, from which a central tubular post A' arises. Two openings  $a, a'$ , small in the base serve for the admission of gas and compressed air, which are fed from suitable reservoirs—not shown herein as their construction and operation are well understood and as they form no part of the invention herein claimed. The gas and air are mingled in proper proportions

and burned or exploded at the proper time, as hereinafter explained. The gas and air escape through an orifice or port  $a^2$ , Fig. 2, in a bearing  $a^3$  on top of the tubular post A'.

Reaction-arms B', B<sup>2</sup>, B<sup>3</sup>, in this instance three in number, are shown as arranged equidistantly around their tubular journal B, which turns freely on the bearing  $a^3$ . The reaction-arms are tubular and open from end to end; their inner ends in their revolution successively pass over the port or orifice  $a^2$ , and thus admit of the escape of the mingled gas and air through them at such times. This construction obviates the necessity of employing special valves, the journal itself performing their functions, cutting off and admitting the gas and air automatically at proper intervals. About one-third of the distance from their outer ends each of the arms are bent backward at an angle of about thirty-five degrees to give the right impetus to them by reaction. A flame-guard or screen  $b$ —preferably formed of a bundle of small tubes—near the outer end of each arm, serves to prevent flame from passing into the arms or bearings. Wire gauze would serve the same purpose, but the tubes are much stronger and will better stand the shock of explosion. The arms are surrounded by a band or rim C, provided with internally projecting abutments or buckets C', inclined backward relatively to the direction of rotation of the arms, so as to stand at about right angles to them. The outer front side of the arms runs as closely to the inner edge of the buckets as they can without touching, their relation being such that the jet from each arm acts on two buckets simultaneously, thus insuring effective reaction. The band and arms might be inclosed in a casing with an opening for the escape of the products of combustion; but I prefer not to use a casing as it makes the parts too hot, and the apparatus is effective without it. The band C may be supported in any suitable way—preferably by a standard C<sup>2</sup> on the bearing  $a^3$ ,—and at the bottom in any suitable way.

In Fig. 1, a band-wheel or fly-wheel D is shown as mounted on an extension of the tubular journal B, constituting a driving-shaft, and affording means of driving other mechanism. The hub D' of the fly-wheel may

also be used as a driving pulley. In Figs. 2 and 3 this extended journal constitutes the driving-shaft of a dynamo, X, which may be of any usual construction which may thus be driven without any gearing, so to speak.

Figs. 1 to 4 show mechanism operated by a succession of explosions, while Fig. 5 shows reaction arms operated by continuous combustion. The only difference in construction between the two plans is that in Fig. 5 where trumpet-shaped air ports  $b'$  are shown as inserted in the front outer end of the arms entering the combustion-chamber of each pipe in front of the frame-guard  $b$  at a slight angle—say of about fifteen degrees. The result of this organization is that as the arms revolve air is forced into and through the combustion chambers, acting to promote combustion not only by direct pressure, but also on the principle of an injector.

Line-wires  $W W'$  lead from any suitable generator of electricity to commutator-springs  $w, w'$  suitably insulated and bearing on rings  $x, x'$  on the revolving shaft or journal B. These rings are suitably insulated from each other and from the shaft. Wires  $z, z'$  lead from these rings to each of the combustion-chambers into which a loop  $z^2$  extends, and is kept sufficiently hot by the current to ignite the gas at all times. Instead of a continuously heated wire, a sparking-current might be used to ignite the gas periodically in well-known ways.

The following is a description of the operation of the apparatus: The mingled gas and air pass up through the hollow post and its port  $a^2$  into and through the reaction-arms, and past the flame-guard,  $b$  into contact with the wire-loops in the combustion chambers which ignites the compound. The expansion thus caused acts on the buckets, but as they are fixed the force exerted reacts upon the arms and forces them to revolve the journal or space between the arms alternately covering and opening the port  $a^2$ , so as to admit and exclude the gas at intervals; thus producing a series of explosions. As explained before, however, the parts may if desired be so arranged as to let the gas flow in and burn continuously, thus acting by continuous expansion instead of intermittent explosions. The speed of the engine can of course be controlled by regulating the gas supply, which can be done in well-known ways. The arms may be made to revolve without the abutments on the Barker mill principle, but the abutments increase the reaction and give greater speed and power.

It will be seen from the foregoing description that I have reduced the machine to its simplest elements, rendering it strictly automatic while doing away with all gearing, and the valves usually used. It will also be noted that ignition takes place just at the point where its effects are to be utilized; thus avoiding the friction of confined chambers or

passages, the shock to the machinery of explosions in closed vessels, and injurious heating.

I claim as of my own invention—

1. The combination, substantially as hereinbefore set forth, of the air and gas mixing chamber, the hollow journal connected therewith, a gas pipe connected with the mixing chamber, an air pipe connected with the mixing chamber, tubular arms mounted on the hollow journal and adapted to revolve thereon, a single exit port in the hollow journal through which the mixed air and gas are delivered to the tubular arms alternately as they revolve about the journal, and igniting apparatus mounted on the arms.

2. The combination, substantially as hereinbefore set forth, of the following instrumentalities: first a chamber for mixing gas and air; second, separate gas and air pipes communicating therewith; third, a tubular journal communicating with the mixing chamber; fourth, tubular radial arms revolving about the journal; fifth, a port connecting the journal and tubular arms at intervals as they revolve; sixth, electrical igniting apparatus revolving with the arms; seventh, tubular flame guards at the outer ends of the arms; and eighth, the abutments against which the ignited gases act as they escape from the tubular arms.

3. The combination, substantially as hereinbefore set forth, of the radial revolving reactionary arms, means for supplying gas and air thereto, the combustion chambers at the outer ends of the arms, flame guards in rear thereof, and abutments arranged in a frame around the arms, for the purpose specified.

4. The combination, substantially as hereinbefore set forth, of revolving radial reactionary arms, means for supplying gas thereto, flame guards near the outer ends of the arms, combustion chambers in front thereof, and air ports ( $b'$ ) opening into the combustion chambers in front of the flame guards and into the atmosphere a short distance in rear thereof.

5. The combination, substantially as hereinbefore set forth, of the tubular upright mixing chamber, a tubular journal communicating with the mixing chamber by a single port, reactionary arms revolving about the journal, and automatically opening and closing the exit port, tubular flame guards at the outer ends of the reactionary arms, electrical igniting devices connected with the combustion chambers in front of the flame guards, an annular frame surrounding the reactionary arms, and abutments carried thereby.

In testimony whereof I have hereunto subscribed my name.

WILLIAM ANTHONY SHAW.

Witnesses:

NELLIE L. HOLMES,  
LLOYD B. WIGHT.