



US006171071B1

(12) **United States Patent**  
**Tzeng et al.**

(10) **Patent No.:** **US 6,171,071 B1**  
(45) **Date of Patent:** **Jan. 9, 2001**

(54) **WATER PUMP HAVING WATER COOLING DEVICE**

(76) Inventors: **Tsann Ruey Tzeng; Sheng Jong Tzeng**, both of No. 35, Pin Yuan Li, Tong Shiau Town, Miao Li Hsien (TW)

(\*) Notice: Under 35 U.S.C. 154(b), the term of this patent shall be extended for 0 days.

(21) Appl. No.: **09/374,007**  
(22) Filed: **Aug. 16, 1999**

(30) **Foreign Application Priority Data**  
Nov. 18, 1998 (TW) ..... 87219204  
(51) **Int. Cl.<sup>7</sup>** ..... **F04B 49/00**  
(52) **U.S. Cl.** ..... **417/279; 417/299; 417/307; 417/311; 417/440**  
(58) **Field of Search** ..... **417/279, 278, 417/299, 307, 311, 284, 440, 243, 297**

(56) **References Cited**  
**U.S. PATENT DOCUMENTS**  
1,070,733 \* 8/1913 Reavell ..... 417/252

2,342,001 *	2/1944	Magnuson .....	60/54.6
2,665,552 *	1/1954	Deardorff .....	60/52
2,700,339 *	1/1955	Schmitt .....	103/42
4,008,012 *	2/1977	Page .....	417/454
4,445,818 *	5/1984	Ohsaki et al. ....	417/288

\* cited by examiner

*Primary Examiner*—Timothy S. Thorpe  
*Assistant Examiner*—Timothy P. Solak  
(74) *Attorney, Agent, or Firm*—Charles E. Baxley

(57) **ABSTRACT**

A water pump includes a housing having a water inlet, a water outlet, an exit and a mouth. A circulating water passage couples the exit to the mouth of the housing. A pump may pump water from the exit to the mouth of the housing via the circulating water passage. The housing includes two ducts communicating with each other and communicating with the mouth, and the water inlet and the water outlet respectively. Two plugs are slidably disposed in the ducts for switching water to circulate through the exit and the circulating water passage when the water outlet is closed.

**10 Claims, 6 Drawing Sheets**

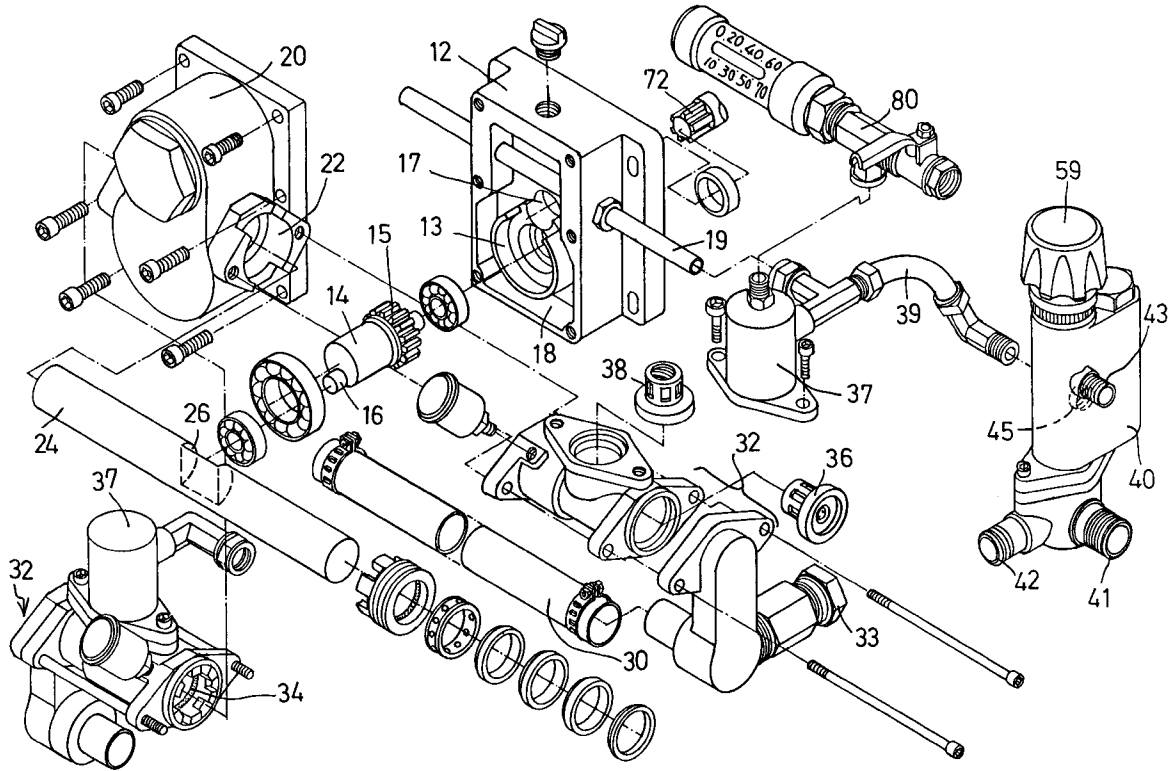

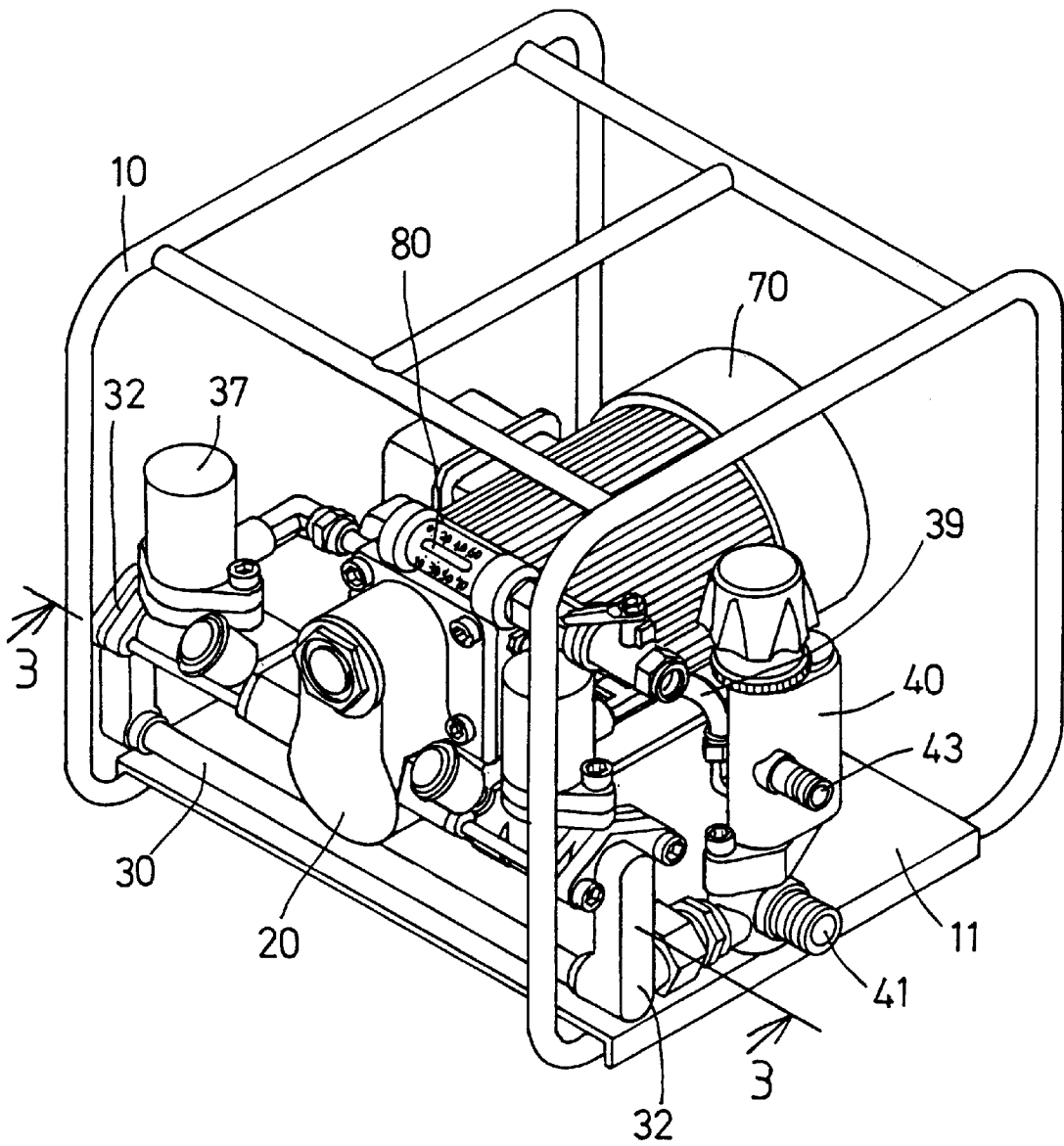

FIG. 1

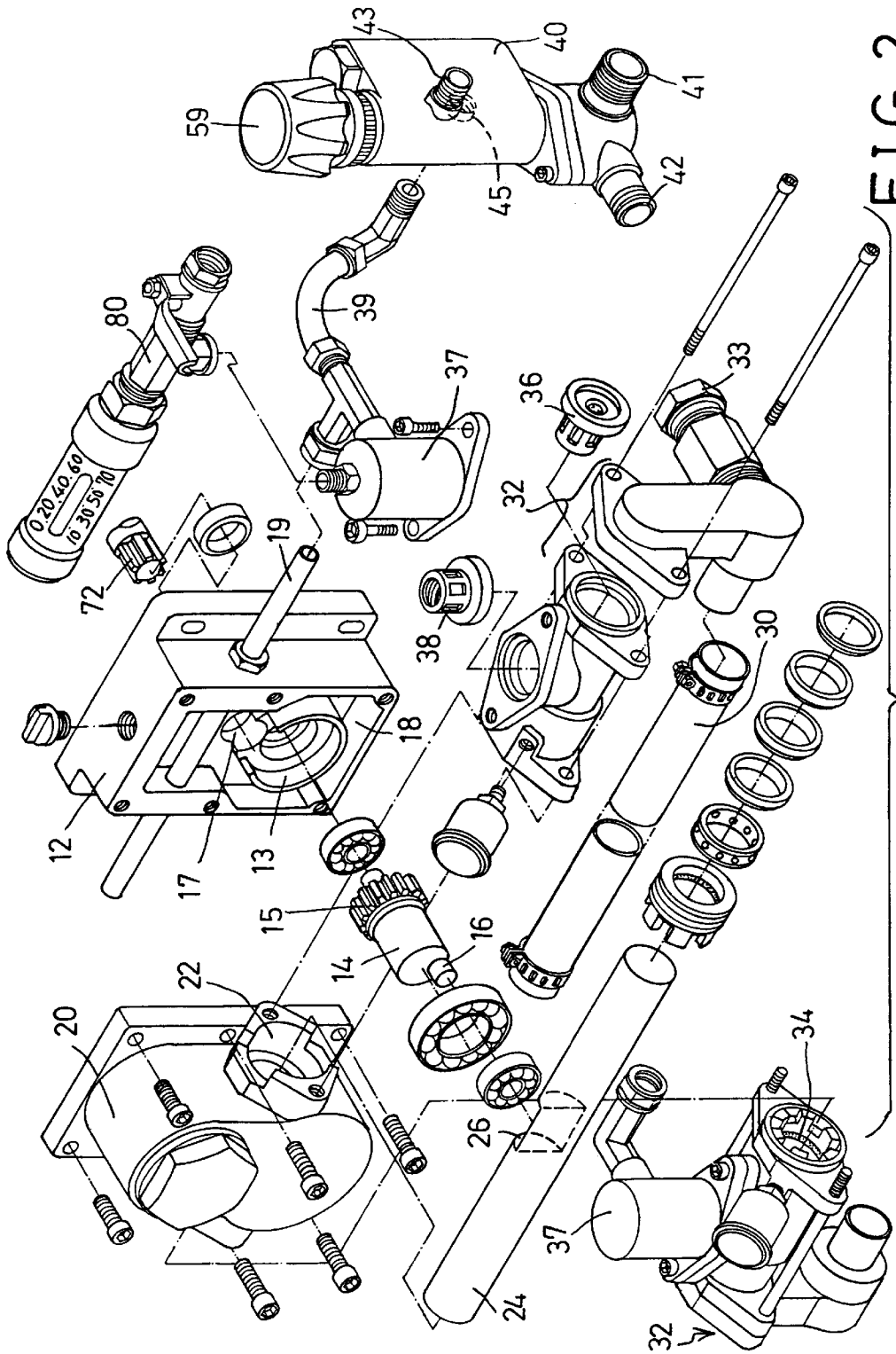

FIG. 2

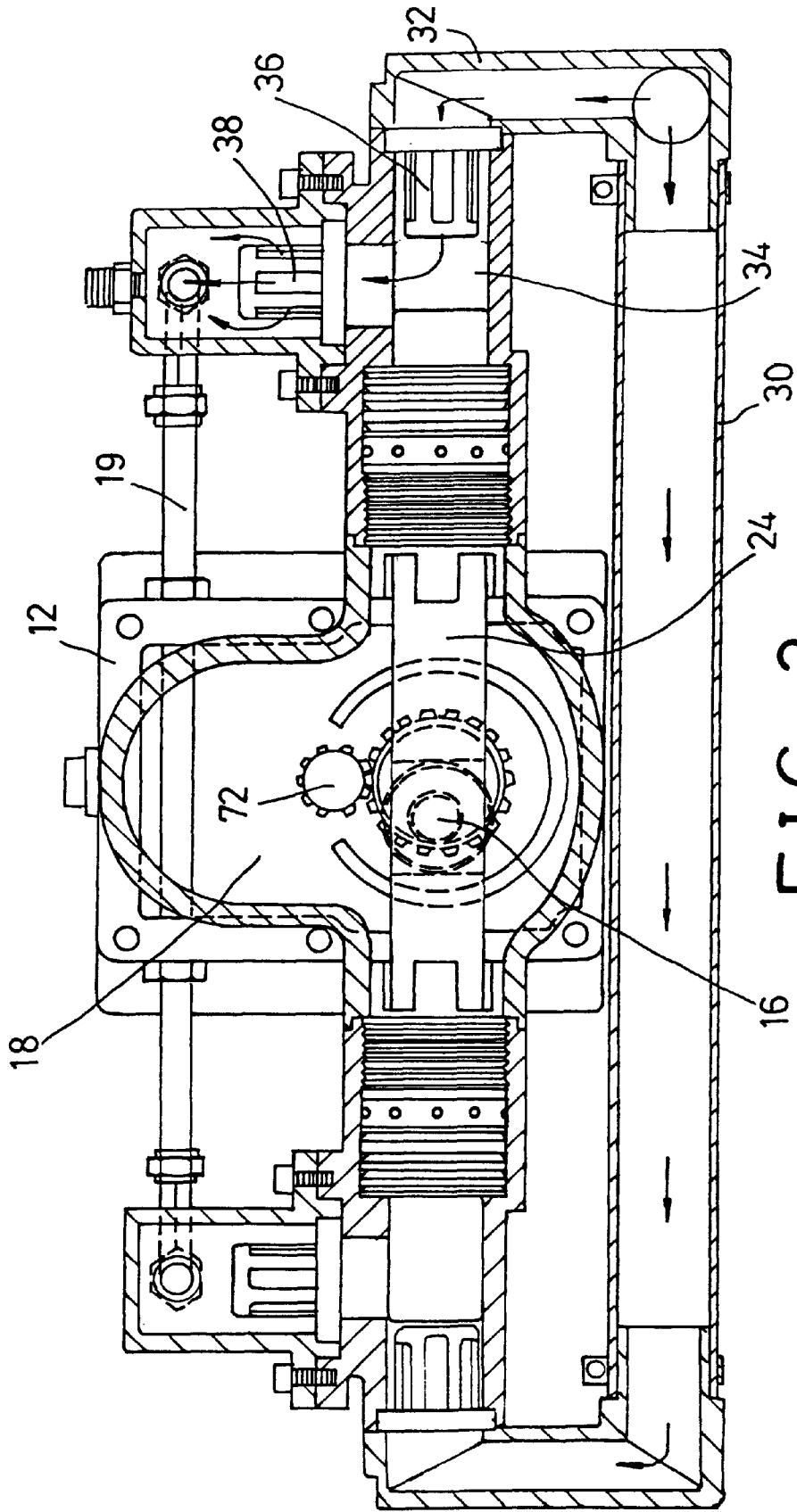

FIG. 3

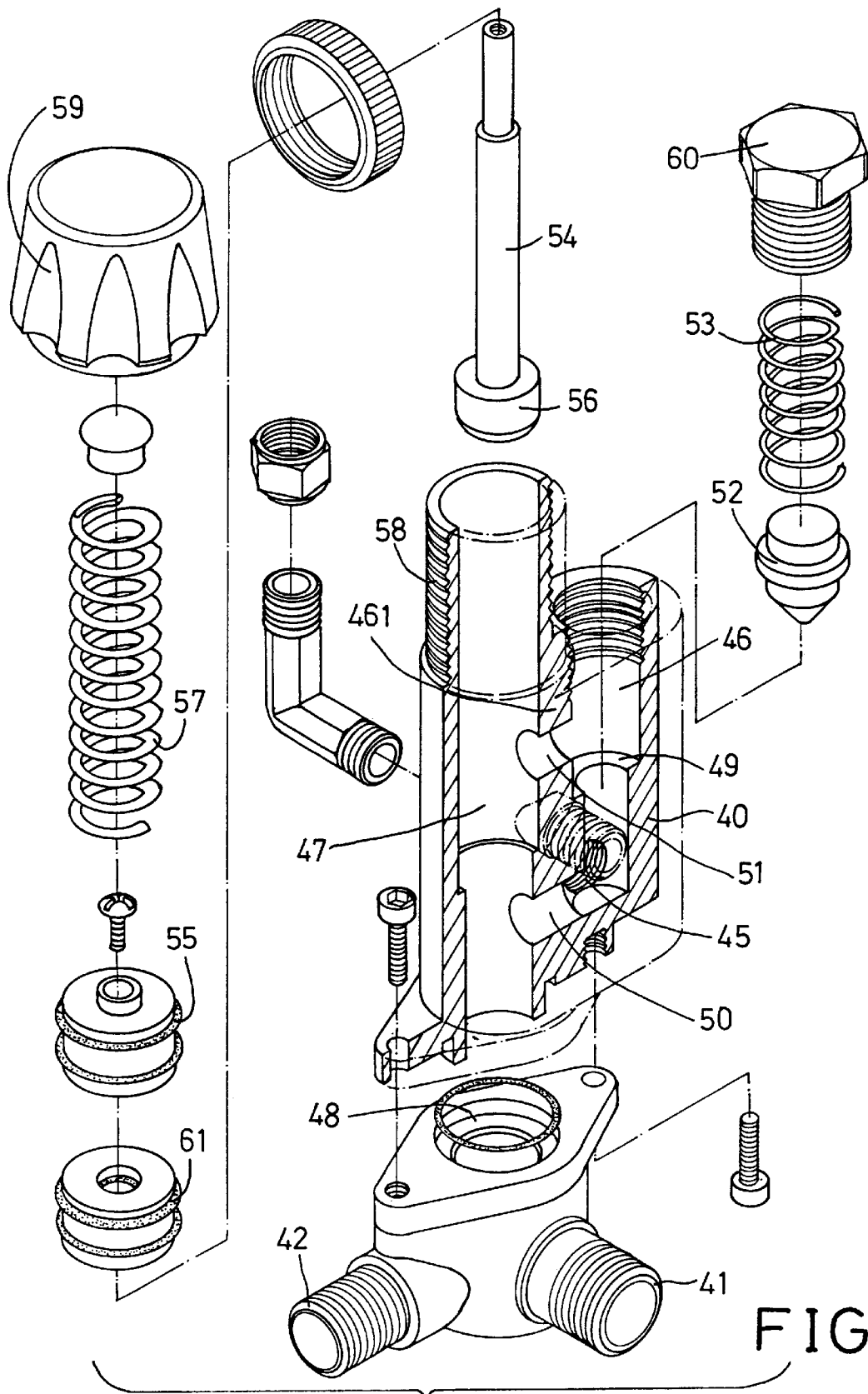

FIG. 4



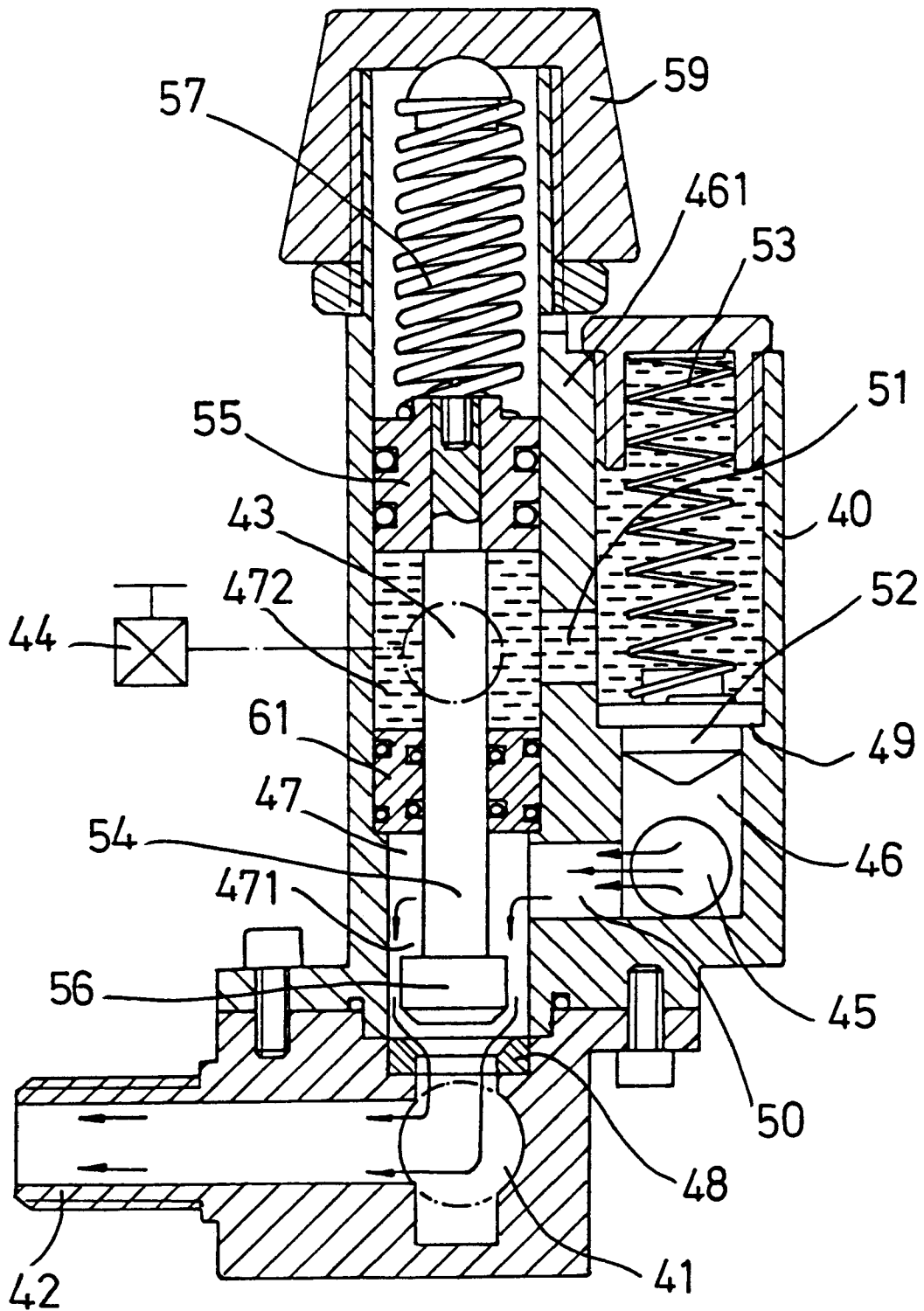

FIG. 7

1

## WATER PUMP HAVING WATER COOLING DEVICE

### BACKGROUND OF THE INVENTION

#### 1. Field of the Invention

The present invention relates to a water pump, and more particularly to a water pump having a water cooling device.

#### 2. Description of the Prior Art

Typical water pumps are provided for pumping water to a reservoir or the like. However, the typical water pumps have no water cooling device for cooling the water pumps. In addition, when the valve in the reservoir is switched off, the water pump some times may still be energized and actuated such that the water pressure in the water pump or in the coupling pipes may be greatly increased and such that the coupling pipes and the other elements may be damaged.

The present invention has arisen to mitigate and/or obviate the afore-described disadvantages of the conventional water pumps.

### SUMMARY OF THE INVENTION

The primary objective of the present invention is to provide a water pump including a pressure relieving device for relieving the pressure in the water passages when the water outlet is switched off and when the water pump is still actuated, and including a cooling device for cooling the water pump.

In accordance with one aspect of the invention, there is provided a water pump comprising a housing having a water inlet and a water outlet and having an exit and a mouth, a circulating water passage coupled between the exit and the mouth of the housing, means for pumping water from the exit to the mouth of the housing via the circulating water passage, and means for switching water to flow out of the water outlet when the water outlet is opened and to circulate through the exit and the circulating water passage when the water outlet is closed.

The circulating water passage includes a first coupler coupled to the exit of the housing, a first receptacle coupled between the first coupler and the mouth, a second coupler and a second receptacle secured together, a tube secured between the first and the second couplers, and a conduit coupled between the first and the second receptacles. A rod is slidably received between the first and the second couplers, and means for moving the rod in a reciprocating action to pump the water in the first and the second couplers to the first and the second receptacles respectively.

The moving means includes a casing, a shaft rotatably secured in the casing and having an eccentric pawl for engaging with and moving the rod, and a rotating means includes a gear provided on the shaft, and a motor having a pinion engaged with the gear to drive the shaft. The conduit extends through the casing for cooling a lubricating oil received in the casing.

The switching means includes a first duct and a second duct and a partition provided between the first duct and the second duct, the first duct includes a first portion communicating with the mouth and includes a second portion, the second duct includes a first interior portion communicating with the water inlet and includes a second interior portion communicating with the water outlet, the partition includes a first passage communicating the first portion of the first duct with the first interior portion of the second duct and includes a second passage communicating the second portion of the first duct with the second interior portion of the

2

second duct, and means for blocking the first interior portion of the second duct when the water outlet is opened.

The switching means includes a separator gasket secured between the second and the first interior portions, a first valve seat provided between the water inlet and the first interior portion of the second duct, a first plug for engaging with the first valve seat, and means for biasing the first plug to engage with the first valve seat when the water outlet is closed. The switching means includes a second valve seat provided between the first and the second portions of the first duct, a second plug for engaging with the second valve seat, and means for biasing the second plug to engage with the second valve seat when the water outlet is closed.

Further objectives and advantages of the present invention will become apparent from a careful reading of a detailed description provided hereinbelow, with appropriate reference to accompanying drawings.

### BRIEF DESCRIPTION OF THE DRAWINGS

FIG. 1 is a perspective view of a water pump;

FIG. 2 is an exploded view of the water pump;

FIG. 3 is a cross sectional view taken along lines 3—3 of FIG. 1;

FIG. 4 is an exploded view of a pressure relieving device;

FIG. 5 is a cross sectional view of the pressure relieving device; and

FIGS. 6 and 7 are cross sectional views showing the operation of the pressure relieving device.

### DETAILED DESCRIPTION OF THE PREFERRED EMBODIMENT

Referring to the drawings, and initially to FIGS. 1—3, a water pump in accordance with the present invention comprises a body 10 including a casing 12 secured on a base 11 of the body 10. A shaft 14 is rotatably received in a bore 13 of the casing 12 and includes a gear 15 provided on one end thereof and includes a cam or an eccentric pawl 16 extended from the other end thereof. The casing 12 includes a chamber 18 formed therein for receiving lubricating grease or oil and includes an orifice 17 formed therein for rotatably receiving a pinion 72 of a motor 70. The pinion 72 of the motor 70 is engaged with the gear 15 of the shaft 14 for rotating the shaft 14. A cover 20 is secured to the casing 12 and includes a lateral aperture 22 formed therein for slidably receiving a rod 24 which includes a depression 26 formed therein for receiving the pawl 16 of the shaft 14 and for allowing the rod 24 to be moved laterally in the aperture 22 of the cover 20 in a reciprocating action. A conduit 19 is engaged through the casing 12 and engaged in the chamber 18 of the casing 12 for receiving water therein and for cooling the lubricating grease received in the chamber 18 of the casing 12.

Two couplers 32 are coupled to the ends of a tube 30 and each includes a check valve 36 engaged therein and each includes an opening 34 formed therein for slidably receiving the ends of the rod 24. One of the couplers 32 includes an entrance 33 provided therein for receiving water from a housing 40 of a pressure relieving device and for allowing the water to flow into the other coupler 32 via the tube 30. Two receptacles 37 are secured between the couplers 32 and the ends of the conduit 19 respectively and each includes a check valve 38 secured therein. As shown in FIG. 3, the rod 24 that is driven by the motor 70 may be moved in the reciprocating action by the motor 70 to pump the water from the couplers 32 to the conduit 19 via the receptacles 37 and

by the provision of the check valves **36, 38**. A pressure gage and/or a flow meter **80** may further be provided and coupled to one of the receptacles **37** for detecting the water pressure and/or the water flow speed in the pipings.

Referring next to FIGS. **4** and **5**, and again to FIGS. **1** and **2**, the housing **40** of the pressure relieving device includes a water inlet **41** coupled to a water reservoir for receiving the water therefrom, and includes an exit **42** coupled to the entrance **33** of the coupler **32** for supplying the water to the tube **30** and the conduit **19**, and includes a water outlet **43** for output the water and includes a faucet or a control valve **44** (FIGS. **5-7**) coupled to the water outlet **43** for controlling the water flowing through the water outlet **43**, and includes a mouth **45** coupled to one of the receptacles **37** by a hose **39**. The housing **40** includes two ducts **46, 47** formed therein and preferably formed in parallel to each other and separated from each other by a partition **461**. A valve seat **48** is formed in the bottom of the duct **47**, and another valve seat **49** is formed in the middle portion of the other duct **46**. The partition **461** includes two passages **50, 51** formed therein for communicating the lower portions and the upper portions of the ducts **46, 47** respectively.

A plug **52** is slidably received in the upper portion of the duct **46** and biased to engage with the valve seat **49** by a spring **53**. A cap **60** may be secured to the duct **46** for retaining the spring **52** and the plug **52** in the duct **46**. A separator gasket **61** is secured in the middle portion of the duct **47** for separating the inner portion of the duct **47** into a lower interior portion **471** and an upper interior portion **472**. A pole **54** is slidably engaged through the gasket **61** and includes a plug **56** secured to the bottom portion thereof for engaging with the valve seat **48** and includes an upper end secured to a slide gasket **55** for engaging with a spring **57**. The duct **47** includes an outer thread **58** formed in the upper portion thereof for threading with a knob **59** which is engaged with the spring **57** and which may be used to adjust the spring biasing force of the spring **57** against the gasket **55** and the pole **54** by threading the knob **59** relative to the duct **47**. The mouth **45** is communicating with the lower portion of the duct **46** and communicating with the lower interior portion **471** of the duct **47** via the passage **50**. The water outlet **43** is communicating with the upper interior portion **472** of the duct **47** which is communicating with the upper portion of the duct **46** via the passage **51**.

In operation, as shown in FIG. **5**, when water is supplied into the water inlet **41** of the housing **40** and when the water outlet **43** is opened for allowing the water to flow out of the housing **40** via the water outlet **43**, the pressure in the upper interior portion **472** of the duct **47** is relieved and the spring **57** may bias the plug **56** to engage with the valve seat **48**. The water from the water inlet **41** may flow into the tube **30** and may be pumped, by the rod **24**, to the conduit **19** and then pumped into the lower portion of the duct **46** via the mouth **45**. The water flowing through the conduct **19** may be used for cooling the lubricating grease received in the chamber **18** of the casing **12**. Because the valve seat **48** is blocked by the plug **56**, the water from mouth **45** may thus force the plug **52** against the spring **53** and may thus flow out through the water outlet **43**.

As shown in FIG. **6**, when the water outlet **43** is closed by the valve **44**, the water flowing into the upper interior portion **472** of the duct **47** may force the gasket **55** and thus the pole **54** upward against the spring **57** such that the plug **56** may be disengaged from the valve seat **48**. As shown in FIG. **7**, when the plug **56** is disengaged from the valve seat **48**, the water from the mouth **45** may thus flow into the tube **30** via the exit **42** of the housing **40** and will no longer flow

through the valve seat **49** and the passage **51** and the upper interior portion **472** of the duct **47**. The spring **53** may thus bias the plug **52** to block the valve seat **49** again. The water may still be pumped into the conduit **19** by the motor **70** via the rod **24** and may circulate through the tube **30** via the mouth **45** of the housing **40**, such that no water pressure will be built within the circulating water passage including the tube **30** and the conduit **19** and the water passage from the mouth **45** to the exit **42** of the housing **40**. However, it is to be noted that, without the tube **30** and the conduit **19**, the water pumped into the mouth **45** of the housing **40** from one of the receptacles **37** and the hose **39** may also circulate or bypass through the passage **50** and the lower interior portion **472** of the duct **47** and the exit **42** of the housing **40** and then may flow to the receptacle **37** and the hose **39** again, such that the water also will not be pressurized.

Accordingly, the water pump includes a pressure relieving device for relieving the pressure in the water passages when the water outlet is switched off and when the water pump is still actuated. The water pump includes a device for cooling the water pump.

Although this invention has been described with a certain degree of particularity, it is to be understood that the present disclosure has been made by way of example only and that numerous changes in the detailed construction and the combination and arrangement of parts may be resorted to without departing from the spirit and scope of the invention as herein after claimed.

We claim:

1. A water pump comprising:

a pressure relieving device including a housing having a water inlet for receiving water from a water reservoir and including a water outlet for outward flow of the water, said housing including an exit and a mouth provided therein,

a circulating water passage coupled between said exit and said mouth of said housing,

means for pumping water from said exit of said housing to said mouth of said housing via said circulating water passage, and

means for switching water to flow out of said water outlet when said water outlet is opened and to circulate through said exit and said circulating water passage when said water outlet is closed.

2. The water pump according to claim 1, wherein said circulating water passage includes a first coupler coupled to said exit of said housing, a first receptacle secured to said first coupler and coupled to said mouth of said housing.

3. The water pump according to claim 2 further comprising a second coupler, a second receptacle secured to said second coupler, a tube secured between said first coupler and said second coupler, and a conduit coupled between said first receptacle and said second receptacle.

4. The water pump according to claim 3, wherein said pumping means includes a rod slidably received between said first coupler and said second coupler, and means for moving said rod in a reciprocating action to pump the water in said first and said second couplers to said first and said second receptacles respectively.

5. The water pump according to claim 4, wherein said moving means includes a casing, a shaft rotatably secured in said casing and having an eccentric pawl extended therefrom for engaging with said rod and for moving said rod in said reciprocating action, and means for rotating said shaft and said eccentric pawl.

6. The water pump according to claim 5, wherein said rotating means includes a gear provided on said shaft, and a motor having a pinion engaged with said gear to drive said shaft.

7. The water pump according to claim 5, wherein said conduit extends through said casing for cooling a lubricating oil received in said casing.

5

8. The water pump according to claim 1, wherein said switching means includes a first duct and a second duct and a partition provided between said first duct and said second duct, said first duct includes a first portion communicating with said mouth and includes a second portion, said second duct includes a first interior portion communicating with said water inlet and includes a second interior portion communicating with said water outlet, said partition includes a first passage communicating said first portion of said first duct with said first interior portion of said second duct and includes a second passage communicating said second portion of said first duct with said second interior portion of said second duct, and means for blocking said first interior portion of said second duct when said water outlet is opened.

6

9. The water pump according to claim 8, wherein said switching means includes a separator gasket secured between said second and said first interior portions, a first valve seat provided between said water inlet and said first interior portion of said second duct, a first plug for engaging with said first valve seat, and means for biasing said first plug to engage with said first valve seat when said water outlet is closed.

10. The water pump according to claim 9, wherein said switching means includes a second valve seat provided between said first and said second portions of said first duct, a second plug for engaging with said second valve seat, and means for biasing said second plug to engage with said second valve seat when said water outlet is closed.

\* \* \* \* \*