

April 10, 1951

E. M. LEICHTLE  
THERMOSTATICALLY RELEASED FURNACE DRAFT  
CHECKING SAFETY DEVICE

2,548,267

Filed May 1, 1947

2 Sheets-Sheet 1

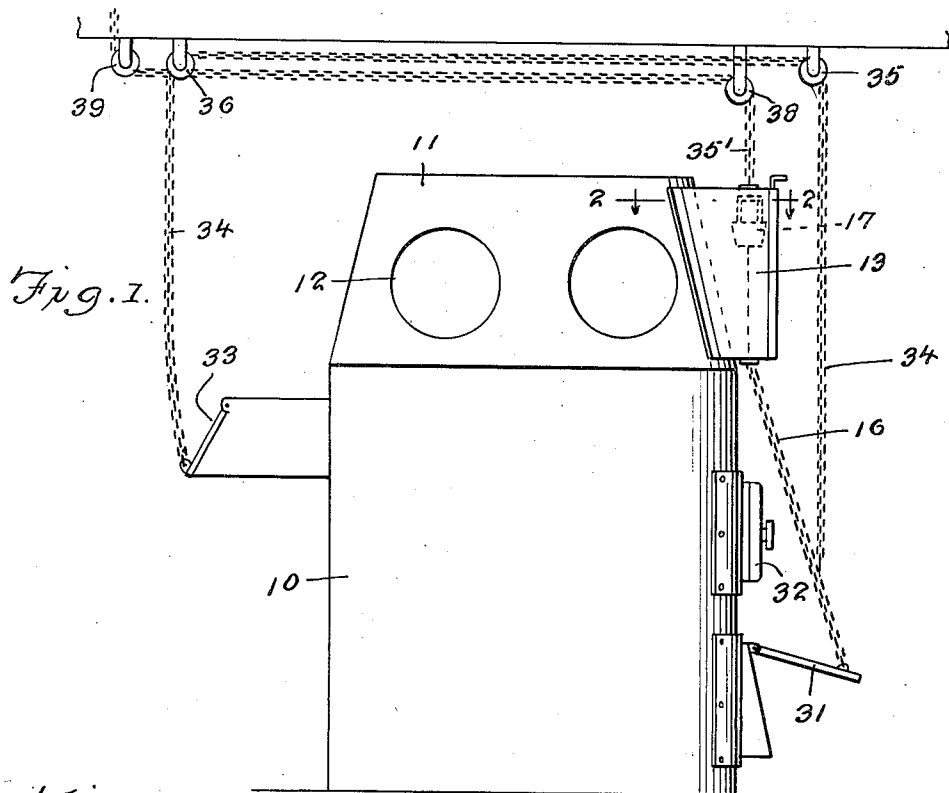

*Fig. 2.*

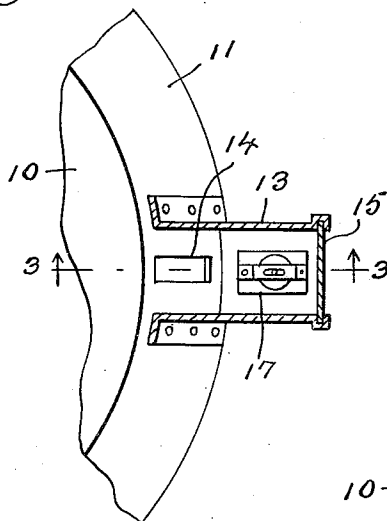

*Fig. 3.*

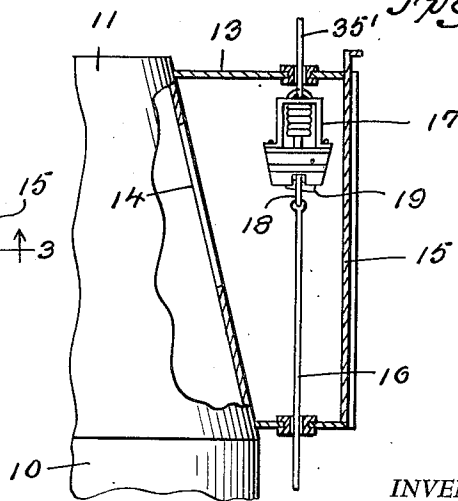

INVENTOR.  
Eugene M. Leichtle

BY *Victor J. Evans & Co.*

ATTORNEYS

April 10, 1951

E. M. LEICHTLE  
THERMOSTATICALLY RELEASED FURNACE DRAFT  
CHECKING SAFETY DEVICE

2,548,267

Filed May 1, 1947

2 Sheets-Sheet 2

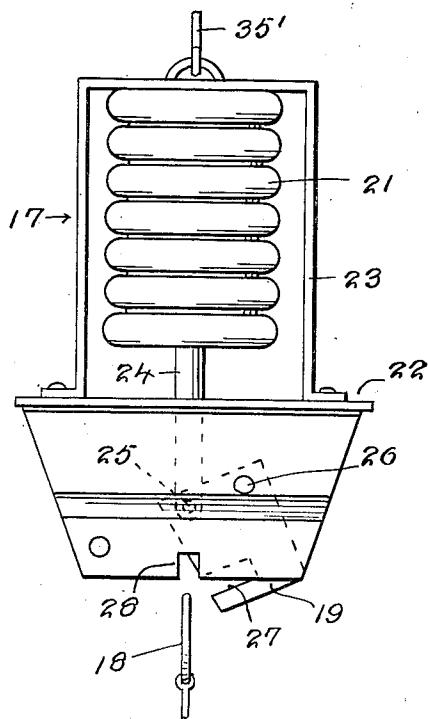
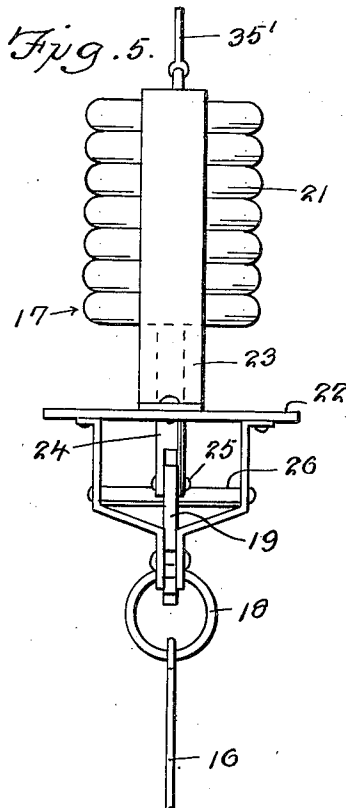
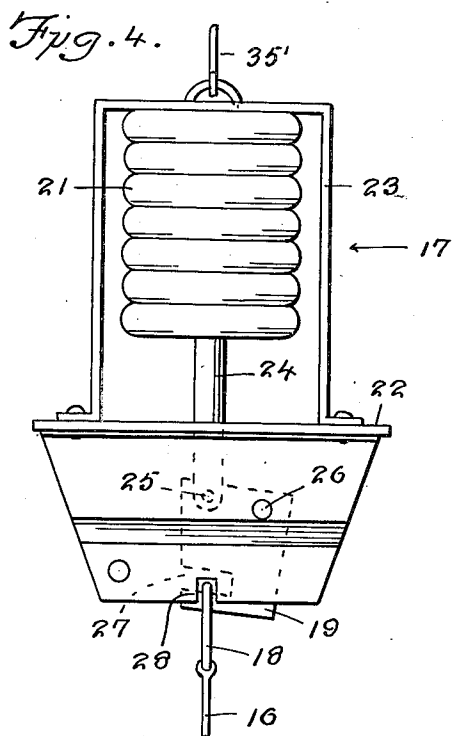

Fig. 6.

INVENTOR  
Eugene M. Leichtle

BY Victor J. Evans & Co.

ATTORNEYS

# UNITED STATES PATENT OFFICE

2,548,267

## THERMOSTATICALLY RELEASED FURNACE DRAFT CHECKING SAFETY DEVICE

Eugene M. Leichtle, Milwaukee, Wis.

Application May 1, 1947, Serial No. 745,195

3 Claims. (Cl. 126—290)

1

This invention relates to draft control arrangements for furnaces.

It is an object of the present invention to provide a sensitive draft control arrangement for furnaces so as to prevent the furnace from becoming overheated and causing fire and wherein said draft control arrangement is of simple construction, easy to install, is not dependent upon electrical controls, inexpensive to manufacture and efficient in operation.

For other objects and for a better understanding of the invention, reference may be had to the following detailed description taken in connection with the accompanying drawing, in which

Fig. 1 is a side elevational view of a furnace with the draft control arrangement of the present invention attached thereto,

Fig. 2 is a fragmentary and cross-sectional view taken on line 2—2 of Fig. 1,

Fig. 3 is a fragmentary and cross-sectional view taken on line 3—3 of Fig. 2,

Fig. 4 is an enlarged side elevational view of the thermostatic release device,

Fig. 5 is an elevational view of the release device as shown in Fig. 4 except looking in a direction turned ninety degrees therefrom and wherein the ring of the supporting wire for the furnace door is attached to the same.

Fig. 6 is a view similar to Fig. 4 showing the position of the release catch when the thermal element has been expanded to release the ring of the door cable.

Referring now to the figures, 10 represents a furnace having a top part 11 with pipe openings 12 therein. Built into this top part and extending laterally therefrom is an auxiliary casing 13 through which hot air can be extended by way of an opening 14 in the top part. The front of this casing has a lift door 15 which can be raised to attach cable 16 to a thermal release catch 17. The cable 16 has a ring 18 and the release catch device 17 has a pivotally mounted latch 19 which normally retains the ring 18 as in the manner shown in Fig. 4. As long as the bellows type thermostat 21 is contracted, the hook 19 will be retained in the position shown in Fig. 4.

The release device further includes a base 22 with a U-shaped member 23 on the top of the same adapted for retaining bellows 21. A shaft 24 extends downwardly from the bellows and connects with the hook 19 as indicated at 25. This hook 19 is pivoted as indicated at 26 to the base 22 and has a slot 27 therein for receiving the ring 18. In the base 22 is a slot 28 in which the ring 18 is retained by the hook 19. When the

2

bellows become heated the hook 19 is pivoted downwardly as shown in Fig. 6 and the ring 18 will be released. Ring 18 is connected to a cable which extends downwardly for connection with the lower edge of a control or ash door 31 located beneath the fire within the furnace. Above the door 31 is the usual door 32 through which coal is passed to the fire in the furnace.

Upon the door 31 dropping, a control damper 33 at the rear of the furnace for controlling the air inlet to the top of the fire will be opened. The damper 31 is connected by a chain 34 which extends upwardly over pulley 35, pulley 36 and is connected to the lower end of the damper 33. The damper 31 is heavier than the damper 33, hence, it will hold the damper 33 to its raised position.

The thermal release device 17 is suspended within the casing 13 from a chain 35' which extends over pulley 38, pulley 39 and connected to a manual control or regulator on the first floor to retain the door 31 in its raised position by its connection therewith through the thermal element and its associated release.

After the thermal control device has released the door 31, it will be necessary to raise the casing door 15 in order to gain access to the ring 18. The thermal device 17 will be pulled down and engagement will be made of the ring with the hook 19.

While various changes may be made in the detail construction, it shall be understood that such changes shall be within the spirit and scope of the present invention as defined by the appended claims.

I claim:

1. In a draft control for a furnace having a housing with an ash door in the lower part thereof and having an opening in the upper part thereof, the combination which comprises an enclosed auxiliary casing mounted on the upper part of the housing and positioned to cover the said opening therein, a latch pivotally mounted in the said auxiliary casing, a cable carried by the latch and attached to the said ash door for holding the ash door in the open position, and a thermostat positioned in the said auxiliary casing and attached to the said latch whereby the said thermostat actuates the latch to release the cable to close the ash door when the temperature in the auxiliary casing reaches a predetermined degree.

2. In a draft control for a furnace having a housing with an ash door in the lower part thereof and having an opening in the upper part there-

3

of, the combination which comprises an enclosed auxiliary casing mounted on the upper part of the housing and positioned to cover the said opening therein, a latch pivotally mounted in the said auxiliary casing, a door slidably mounted in the outer surface of the auxiliary casing for facilitating resetting the latch, a cable carried by the latch and attached to the said ash door for holding the ash door in the open position, a thermostat positioned in the said auxiliary casing and attached to the said latch whereby the said thermostat actuates the latch to release the cable to close the ash door when the temperature in the auxiliary casing reaches a predetermined degree, a frame in the said auxiliary casing in which the thermostat and latch are carried, and a cable by which the said frame is suspended extended from the said auxiliary casing to a remote point.

3. In a draft control for a furnace having a housing with an ash door in the lower part thereof and having an opening in the upper part thereof, the combination which comprises an enclosed auxiliary casing mounted on the upper part of the housing and positioned to cover the said opening therein, a latch pivotally mounted in the said auxiliary casing, a door slidably mounted in the outer surface of the auxiliary casing for

4

facilitating resetting the latch, a cable carried by the latch and attached to the said ash door for holding the ash door in the open position, a thermostat positioned in the said auxiliary casing and attached to the said latch whereby the said thermostat actuates the latch to release the cable to close the ash door when the temperature in the auxiliary casing reaches a predetermined degree, a frame in the said auxiliary casing in which the thermostat and latch are carried, a damper in connection with a stack connection at the rear, and a cable connected to the damper and to the cable connected to the ash door whereby the damper is opened as the ash door is closed.

EUGENE M. LEICHTLE.

## REFERENCES CITED

The following references are of record in the file of this patent:

## UNITED STATES PATENTS

Number	Name	Date
1,688,121	Larson -----	Oct. 16, 1928
2,190,892	Swepston -----	Feb. 20, 1940
2,302,745	Crise -----	Nov. 24, 1942
2,339,614	Breese -----	Jan. 18, 1944
2,436,275	Wiegiers -----	Feb. 17, 1948