



(51) International Patent Classification:

H04N 23/698 (2023.01) H04N 23/58 (2023.01)
H04N 23/45 (2023.01) H04N 23/90 (2023.01)

(21) International Application Number:

PCT/IB2024/059239

(22) International Filing Date:

23 September 2024 (23.09.2024)

(25) Filing Language:

Italian

(26) Publication Language:

English

(30) Priority Data:

23425050.4 21 September 2023 (21.09.2023) EP

(71) Applicant: **ELETTRONICA S.P.A.** [IT/IT]; Via Tiburtina Valeria Km 13.70, 00131 ROMA (IT).

(72) Inventors: **BALDISSERRI, Roberto**; c/o ELETTRONICA S.P.A., Via Tiburtina Valeria Km 13.70, 00131 ROMA

(IT). **DALOISO, Silvia**; c/o ELETTRONICA S.P.A., Via Tiburtina Valeria Km 13.70, 00131 ROMA (IT). **PISTOIA, Daniela**; c/o ELETTRONICA S.P.A., Via Tiburtina Valeria Km 13.70, 00131 ROMA (IT).

(74) Agent: **STUDIO TORTA S.P.A.**; Via Viotti, 9, 10121 TORINO (IT).

(81) Designated States (unless otherwise indicated, for every kind of national protection available): AE, AG, AL, AM, AO, AT, AU, AZ, BA, BB, BG, BH, BN, BR, BW, BY, BZ, CA, CH, CL, CN, CO, CR, CU, CV, CZ, DE, DJ, DK, DM, DO, DZ, EC, EE, EG, ES, FI, GB, GD, GE, GH, GM, GT, HN, HR, HU, ID, IL, IN, IQ, IR, IS, IT, JM, JO, JP, KE, KG, KH, KN, KP, KR, KW, KZ, LA, LC, LK, LR, LS, LU, LY, MA, MD, MG, MK, MN, MU, MW, MX, MY, MZ, NA, NG, NI, NO, NZ, OM, PA, PE, PG, PH, PL, PT, QA, RO, RS, RU, RW, SA, SC, SD, SE, SG, SK, SL, ST, SV, SY, TH,

(54) Title: INNOVATIVE DRONE AND AIRCRAFT DETECTION SYSTEM

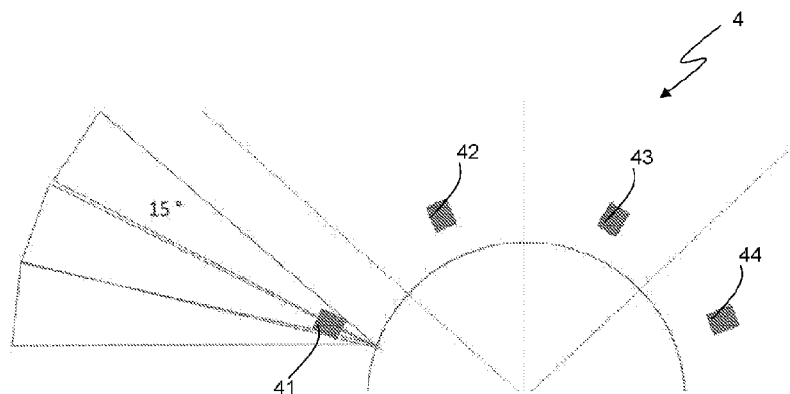

Fig. 5

(57) Abstract: The invention concerns System for detecting drones and aircraft, designed to be installed to defend a site or mobile platform against enemy/hostile drones and aircraft. Said system comprises an image/video acquisition system that includes: N modules (31, 32, 33, 34) arranged at 360° around a vertical central axis (y) of said image/video acquisition system, wherein said vertical central axis (y) is perpendicular to a horizontal plane of said image/video acquisition system, N being an integer greater than one; for each module (31, 32, 33, 34), at least one respective infrared or electro-optical sensor (21, 41, 42, 43, 44, 51) having a given Field of View in azimuth, i.e. parallel to the horizontal plane, and a given Field of View in elevation, i.e. parallel to the vertical central axis (y); for each module (31, 32, 33, 34), at least one respective mirror or prism associated with respective sensor (21, 41, 42, 43, 44, 51) and movable, preferably rotatable, so as to increase the given Field of View in azimuth of said respective sensor (21, 41, 42, 43, 44, 51), so that sensors (21, 41, 42, 43, 44, 51) of all modules (31, 32, 33, 34) provide, altogether, a Field of Regard in azimuth of 360°. The system for detecting drones and aircraft also comprises: a processing system based on artificial intelligence and trained to detect drones and/or aircraft on the basis of the images/video streams provided by the image/video acquisition system; and a control system configured to move the mirrors/prisms and actuate sensors (21, 41, 42, 43, 44, 51) of various modules (31, 32, 33, 34) in a synchronised manner with each other so as to obtain, for the image/video acquisition system as a whole, said Field of Regard in azimuth of 360°.

TJ, TM, TN, TR, TT, TZ, UA, UG, US, UZ, VC, VN, WS,
ZA, ZM, ZW.

- (84) Designated States** (*unless otherwise indicated, for every kind of regional protection available*): ARIPO (BW, CV, GH, GM, KE, LR, LS, MW, MZ, NA, RW, SC, SD, SL, ST, SZ, TZ, UG, ZM, ZW), Eurasian (AM, AZ, BY, KG, KZ, RU, TJ, TM), European (AL, AT, BE, BG, CH, CY, CZ, DE, DK, EE, ES, FI, FR, GB, GR, HR, HU, IE, IS, IT, LT, LU, LV, MC, ME, MK, MT, NL, NO, PL, PT, RO, RS, SE, SI, SK, SM, TR), OAPI (BF, BJ, CF, CG, CI, CM, GA, GN, GQ, GW, KM, ML, MR, NE, SN, TD, TG).

Published:

- *with international search report (Art. 21(3))*
- *before the expiration of the time limit for amending the claims and to be republished in the event of receipt of amendments (Rule 48.2(h))*
- *in black and white; the international application as filed contained color or greyscale and is available for download from PATENTSCOPE*

INNOVATIVE DRONE AND AIRCRAFT DETECTION SYSTEM

Cross-Reference to Related Applications

This Patent Application claims priority from European Patent
5 Application No. 23425050.4 filed on September 21, 2023, the
entire disclosure of which is incorporated herein by
reference.

Technical Sector of the Invention

The present invention concerns an innovative system
10 designed to detect drones and aircraft and intended to be
installed to defend a site or mobile platform (e.g., a land
vehicle or naval unit) against enemy/hostile drones and
aircraft.

Background Art

15 Systems of the C-UAS-type (Counter-Unmanned Aircraft
System), also commonly known as anti-drone systems, can be
considered, from a systems engineering point of view, as a
system of systems that includes a set of actuators, a set of
sensors and a command and control system for said actuators
20 and sensors. Such systems include radars as one of their
main sensors. However, under certain operating conditions,
radars can cause false alarms, be a factor creating
difficulties in detection and, being active elements, they
can also increase the possibility of being detected by
25 possible opponents.

In this context, the electro-optical subsystems
currently used as sensors in the C-UAS systems operate based
on radar designation, i.e. they do not perform any discovery
functions.

30 Most of the electro-optical and infrared sensors in use
today in the C-UAS systems offer the possibility of on-axis
rotation that permits to have a panoramic view in a given
time; this rotation is usually combined with a pan-and-tilt
possibility, which allows the elevation thereof to be

changed. Such sensors (typically cameras) are, therefore, dedicated to spotting a potential drone only after being designated by the radar. They also have a narrow Field of View (FoV), typically of the order of 4°, and cannot, therefore, spot or track objects outside this FoV, nor are they able to spot or track multi-drone attacks from multiple directions.

The electro-optical and infrared cameras in use in the current C-UAS systems are not capable of performing any discovery functions, as rotation on pan-and-tilt systems, in light of the reduced FoV, would take time that is not compatible with the operating requirements; moreover, the continuous rotation of the system would cause premature wear of the system itself, leading to the need for continuous maintenance.

Object and Summary of the Invention

In light of the above, the Applicant felt the need to develop an innovative technology for the C-UAS systems capable of overcoming or alleviating, at least in part, the disadvantages and limitations of the technologies of known type, thus arriving at the present invention.

Therefore, aim of the present invention is to provide an innovative system for detecting drones and aircraft that can overcome or alleviate, at least in part, the advantages and limitations of currently known technologies.

This and other aims are achieved by the present invention as it relates to a system for detecting drones and aircraft, as defined in the appended claims.

In particular, the present invention concerns a system for detecting drones and aircraft, designed to be installed to defend a site or mobile platform against enemy/hostile drones and aircraft. Said system comprises an image/video acquisition system that includes:

• N modules arranged at 360° around a vertical central axis of said image/video acquisition system, wherein said vertical central axis is perpendicular to a horizontal plane of said image/video acquisition system, N being an integer greater than one;

• for each module, at least one respective infrared (IR) or electro-optical sensor having a given Field of View (FoV) in azimuth, i.e. parallel to the horizontal plane, and a given FoV in elevation, i.e. parallel to the vertical central axis;

• for each module, at least one respective mirror or prism associated with the respective sensor and movable, preferably rotatable, so as to increase the given FoV in azimuth of said respective sensor, so that the sensors of all modules provide, altogether, a Field of Regard (FoR) in azimuth of 360°.

The system for detecting drones and aircraft also comprises:

• a processing system based on artificial intelligence (AI) and trained to detect drones and/or aircraft on the basis of the images/video streams provided by the image/video acquisition system; and

• a control system configured to move the mirrors/prisms and actuate the sensors of the various modules in a synchronised manner with each other so as to obtain, for the image/video acquisition system as a whole, said FoR in azimuth of 360°.

Brief Description of the Drawings

For a better understanding of the present invention, certain preferred embodiment, which are intended purely by way of non-limiting or non-binding examples, will now be described with reference to the accompanying drawings (all not to scale), wherein Figures 1-9 schematically show

various/different features of a system for detecting drones and aircraft and, more specifically, of an image/video acquisition system of said system for detecting drones and aircraft according to preferred embodiment of the present invention.

Detailed Description of Possible Embodiments of the Invention

The following description is provided to enable a person skilled in the art to make and use the invention. Various modifications to the embodiments set forth will be immediately clear to the persons skilled in the art and the general principles herein disclosed may be applied to other embodiments and applications without, however, departing from the protection scope of the present invention as defined in the enclosed claims.

Therefore, the present invention should not be understood as limited to the sole embodiments described and shown, but it must be given the widest scope of protection in accordance with the characteristics defined in the appended claims.

The present invention concerns a system for detecting drones and aircraft, designed to be installed to defend a site or mobile platform (e.g. a land vehicle or naval unit) against drones (i.e. Unmanned Aerial Vehicles - UAVs) and enemy/hostile aircraft. Said system comprises an image/video acquisition system that includes:

- N modules arranged at 360° around a vertical central axis of said image/video acquisition system, wherein said vertical central axis is perpendicular to a horizontal plane of said image/video acquisition system, N being an integer greater than one;
- for each module, at least one respective infrared (IR) or electro-optical sensor having a given Field of View (FoV) in azimuth, i.e. parallel to the horizontal plane, and a

given FoV in elevation, i.e. parallel to the vertical central axis;

- for each module, at least one respective mirror or prism associated with the respective sensor and movable, preferably rotatable, so as to increase the given FoV in azimuth of said respective sensor, so that the sensors of all modules provide, altogether, a Field of Regard (FoR) in azimuth of 360°.

The system for detecting drones and aircraft also comprises:

- a processing system based on artificial intelligence (AI) and trained to detect drones and/or aircraft on the basis of the images/video streams provided by the image/video acquisition system; and
- a control system configured to move the mirrors/prisms and actuate the sensors of the various modules in a synchronised manner with each other so as to obtain, for the image/video acquisition system as a whole, said FoR in azimuth of 360°.

Conveniently, for each module, the respective mirror/prism is movable, preferably rotatable, so as to increase also the given FoV in elevation of the respective sensor, so that the sensors of all the modules altogether provide a predefined FoR in elevation greater than said FoV in elevation; conveniently, the control system is configured to move the mirrors/prisms and actuate the sensors of the various modules in a synchronised manner with each other so as to obtain, for the image/video acquisition system as a whole, also said predefined FoR in elevation.

Preferably, the image/video acquisition system includes a master unit and a slave unit operationally synchronised with each other, wherein said master unit and slave unit each comprise $N/2$ modules, and wherein N is an even integer.

Conveniently, the processing system includes neural

networks trained to:

- analyse the image/video streams provided by the image/video acquisition system;

- detect the presence of a drone or aircraft in the analysed image/video streams;

- confirm the presence of a drone/aircraft in the image/video streams by analysing the kinematics of the detected objects;

- calculate a future point of the detected object to enable a correct pointing of kinetic actuators.

Preferably, the processing system includes neural networks trained to detect, identify and classify drones and aircraft on the basis of the images/video streams provided by the image/video acquisition system.

Preferably, the image/video acquisition system includes, for each module, a plurality of sensors comprising at least one infrared sensor and at least one electro-optical sensor.

As described above, in contrast to current solutions, the system according to the present invention preferably comprises a photocamera/camera that does not move via pan-and-tilt type systems, but is conveniently equipped with a set of optics arranged radially along a circumference for 360° coverage around the photocamera/camera. Conveniently, it is also possible to arrange the optics on several circular sectors to achieve 360° coverage even in the presence of observation obstructions, keeping these sectors synchronised by means of a synchronisation signal.

Preferably, the system includes two units, a master unit and a slave unit, wherein each unit comprises a suitable number of modules to cover a 180° Field of Regard (FoR). One of the two units is equipped with at least one Wide (i.e., wide FoV) photocamera/camera placed with the optical axis vertical to the horizon. By way of example, in the case of four modules for each unit, each of these would have an FoR

of 45°, which can be conveniently obtained, as described below, as the sum of the various FoVs of the mirror in the different positions assumed by the latter as a result of movement.

5 Thus, for each electro-optical and/or infrared (IR) sensor:

$$FoR = FoV \times \text{numero posizioni possibili dello specchio sull'asse } x .$$

In particular, each module can conveniently include:

- an IR sensor,
- 10 • an optic compatible with IR wavelength at fixed focal length and variable focus,
- a stepper motor,
- a mirror stand,
- N mirrors placed at different elevation angles (the
15 number of mirrors N being conveniently estimated on the basis of data/predefined operating requirements),
- an image processing module shared with two camera modules.

In this respect, Figure 1 schematically shows an example
20 of a master unit 1 and a slave unit 2. In addition, as shown in Figures 2 and 3, a Wide 21 sensor (i.e., with wide FoV) is installed/arranged centred above one of the two system units (in Figures 2 and 3, merely by way of example, slave unit 2) with the optical axis y' that is vertical/orthogonal
25 with respect to the horizontal plane of the system.

Preferably, a system unit (e.g. master unit 1 or slave unit 2) comprises four (or even more) modules 31, 32, 33, 34 arranged as shown in Figure 4 so as to guarantee that each provides an azimuth coverage of 45° and thus, altogether,
30 180°.

Thanks to the use of a rotating mirror system and to a subdivision of the rotation angle into portions, it is possible to generate a 360° image in a limited time. The video streams thus generated are conveniently analysed by

artificial intelligence (AI) modules - preferably based on neural networks - specially developed and trained for the detection, recognition and identification (DRI) of drones and aircraft.

5 In particular, the neural networks preferably allow to:

- recognise the presence of a drone (or aircraft) in the analysed streams;

- confirm in advance of traditional AI techniques (based on the number of pixels occupied by the object) the presence of a drone/aircraft in the video stream by analysing the kinematics of the detected objects;

- calculate the future point of the detected object to enable the correct pointing of kinetic actuators.

15 The aforementioned architecture allows quick replacement of the sensor block and optics, facilitating maintenance tasks and improving overall performance.

The architecture of the shooting system has been optimised to reduce the number of sensors required, in order to achieve a cost-effective configuration. Better results could be obtained by narrowing the FoV, i.e. by increasing the number of chambers or transitions of the mirrors, but this could lead to an increase in the composition time of the 360° mosaic. By way of example, the use of 8 high-resolution LWIR/SWIR ("Long Wavelength Infrared" / "Short Wavelength Infrared") or MWIR ("Medium Wavelength Infrared") sensors to cover the 360° side band and of one high-resolution LWIR/SWIR or MWIR sensor together with one high-resolution RGB ("Red Green Blue") sensor to cover the vertical areas could be conveniently envisaged. This configuration allows for a lateral band coverage that can be modulated in the elevation angle as a function of the detailed specifications of the system, as shown in Figure 5, which shows an example of the lateral shooting angles of a master or slave module of a system with a fixed camera and

20

25

30

rotating mirror optics with the characteristics described previously. In particular, Figure 5 shows a master or slave 4 module equipped with 4 LWIR/SWIR or MWIR sensors 41, 42, 43, 44 arranged along a semi-circle so that they each cover
5 an angular sector in azimuth around master/slave module 4 of 45° , whereby the 4 LWIR/SWIR or MWIR sensors 41, 42, 43, 44 provide, altogether, a coverage in azimuth of 180° . Furthermore, Figure 5 shows, for one of the sensors (in particular sensor 41), the subdivision of the relevant
10 respective 45° sector into three successive 15° acquisitions made via an appropriate rotation of the mirrors.

LWIR/SWIR or MWIR sensors are conveniently connected to one or more GPUs (Graphics Processing Units).

As explained above, the modular architecture for the
15 various shooting sectors allows both a reduction in costs and greater maintainability of the system.

A stepper-motor-based motorisation with a multi-axis control system slaved to the data acquisition system can be conveniently used to move the mirrors.

20 The timing of the trigger is such that it synchronises the movement of the mirrors and the acquisitions of the chosen video channels.

The two master and slave units are both equipped with a synchronisation component (referred to as a Trigger in Figure
25 1) of the mirror rotation motors.

The synchronisation component reported in Figure 1 keeps the downtimes and the movement times of all mirrors included in the system modules synchronised.

Conveniently, the inclination of the mirrors in
30 elevation is such that at least 5px of overlap at a distance of 1km between two contiguous images in elevation are provided.

In this regard, an example of mirror rotation trigger signals for an RGB sensor and an LWIR sensor is shown in

Figure 6.

Conveniently, in use, the system receives in input a start acquisition signal and returns images at a fixed update rate with appropriate labelling to be able to reconstruct a
5 mosaic/panorama of images to cover $360^{\circ} \times 30^{\circ}$. Scanning is carried out by means of two types of steps of a mirror rotation motor:

- with a movement of a same mirror in azimuth (in this case the steps are smaller and equal to m),
- 10 • with such a movement as to pass from one mirror to another by rotating between n mirrors tilted differently in elevation.

Each sensor is therefore used to construct an image matrix equal to $m \times n$ images in azimuth and in elevation,
15 respectively. An example of an image generation scheme based on the described architecture is shown in Figure 7.

Preferably, for each module the FoV resulting from a scan is equal to 45° over at least 30° in azimuth and elevation, respectively, with a tolerance of $\pm 1^{\circ}$ both in
20 azimuth and in elevation. Each unit offers images that can cover 180° over at least 30° of FoV.

In this respect, Figures 8 and 9 show a master or slave unit 5 wherein an IR sensor provides coverage (i.e. FoV) of 45° in azimuth (Figure 8 - top view) and of 30° in elevation
25 (Figure 9 - side view).

From the above description, the many innovative features of the present invention and its countless technical advantages are immediately obvious to a technician in the field.

30 In particular, it is important to emphasise that the present invention makes it possible to improve the ability to discover, recognise and classify drones and aircraft over long distances, so as to aid the management of both military and civil operations, such as for example the protection of

sensitive sites, like operations centres or command posts, and the protection of moving targets such as motorcades, convoys or individual vehicles.

The present invention defines an innovative architecture
5 to be able to implement a photocamera/camera that makes it possible to drop the old pan-and-tilt concept, and that through a multi-optics with rotating mirrors/prisms allows a 360° view such that, through the integration of artificial intelligence modules, it is made capable of performing the
10 detection, identification and classification of drones and aircraft with extreme accuracy, even over long distance.

The configuration of a camera capable of offering a 360° view through a rotating mirror multi-optics, thanks to the addition of specially trained artificial intelligence
15 modules, makes it possible to reduce the DRI (i.e., detection, recognition and identification) time of drones and aircraft, reducing from a technical point of view the risk of wear and tear caused by the rotation and pan-and-tilt mechanisms of the cameras in use today, and from an
20 operational point of view, it allows the system to remain electromagnetically silent, i.e., not to emit since it has no radar by default.

In conclusion, it is important to note that, while the above described invention refers in particular to very
25 specific embodiments, it must not be intended as limited to such embodiments, including within its scope all the variants, modifications or simplifications covered by the enclosed claims.

CLAIMS

1. System for detecting drones and aircraft, designed to be installed to defend a site or mobile platform against enemy/hostile drones and aircraft;

wherein said system comprises an image/video acquisition system that includes:

- N modules (31, 32, 33, 34) arranged at 360° around a vertical central axis (y) of said image/video acquisition system, wherein said vertical central axis (y) is perpendicular to a horizontal plane of said image/video acquisition system, N being an integer greater than one;

- for each module (31, 32, 33, 34), at least one respective infrared or electro-optical sensor (21, 41, 42, 43, 44, 51) having a given Field of View in azimuth, i.e. parallel to the horizontal plane, and a given Field of View in elevation, i.e. parallel to the vertical central axis (y);

- for each module (31, 32, 33, 34), at least one respective mirror or prism associated with respective sensor (21, 41, 42, 43, 44, 51) and movable, preferably rotatable, so as to increase the given Field of View in azimuth of said respective sensor (21, 41, 42, 43, 44, 51), so that sensors (21, 41, 42, 43, 44, 51) of all modules (31, 32, 33, 34) provide, altogether, a Field of Regard in azimuth of 360°;

and wherein the system for detecting drones and aircraft also comprises:

- a processing system based on artificial intelligence and trained to detect drones and/or aircraft on the basis of the images/video streams provided by the image/video acquisition system; and

- a control system configured to move the mirrors/prisms and actuate sensors (21, 41, 42, 43, 44, 51) of various modules (31, 32, 33, 34) in a synchronised manner with each

other so as to obtain, for the image/video acquisition system as a whole, said Field of Regard in azimuth of 360°.

2. The system according to claim 1, wherein, for each module (31, 32, 33, 34), the respective mirror/prism is
5 movable, preferably rotatable, so as to increase also the given Field of View in elevation of respective sensor (21, 41, 42, 43, 44, 51), so that sensors (21, 41, 42, 43, 44, 51) of all modules (31, 32, 33, 34) altogether provide a predefined Field of Regard in elevation greater than said
10 given Field of View in elevation; and wherein the control system is configured to move the mirrors/prisms and actuate sensors (21, 41, 42, 43, 44, 51) of various modules (31, 32, 33, 34) in a synchronised manner with each other so as to obtain, for the image/video acquisition system as a whole,
15 also said predefined Field of Regard in elevation.

3. The system according to claim 1 or 2, wherein the image/video acquisition system includes a master unit (1) and a slave unit (2) operationally synchronised with each other, wherein said master unit (1) and slave unit (2) each
20 comprise $N/2$ modules (31, 32, 33, 34), and wherein N is an even integer.

4. The system according to any one of claims 1 to 3, wherein the processing system includes neural networks trained to:

- 25
- analyse the image/video streams provided by the image/video acquisition system;
 - detect the presence of a drone or aircraft in the analysed image/video streams;
 - confirm the presence of a drone/aircraft in the
30 image/video streams by analysing the kinematics of the detected objects;
 - calculate a future point of the detected object to enable a correct pointing of kinetic actuators.

5. The system according to any one of the preceding

claims, wherein the processing system includes neural networks trained to detect, identify and classify drones and aircraft on the basis of the images/video streams provided by the image/video acquisition system.

5 **6.** The system according to any one of the preceding claims, wherein the image/video acquisition system includes, for each module (31, 32, 33, 34), a plurality of sensors (21, 41, 42, 43, 44, 51) comprising at least one infrared sensor and at least one electro-optical sensor.

10 **7.** The system according to any one of the preceding claims, where the system is installed on board a land vehicle or naval unit.

8. Platform equipped with the system for detecting drones and aircraft as claimed in any preceding claim.

15 **9.** The platform according to claim 8, wherein said platform is a mobile platform, conveniently a land vehicle or a naval unit.

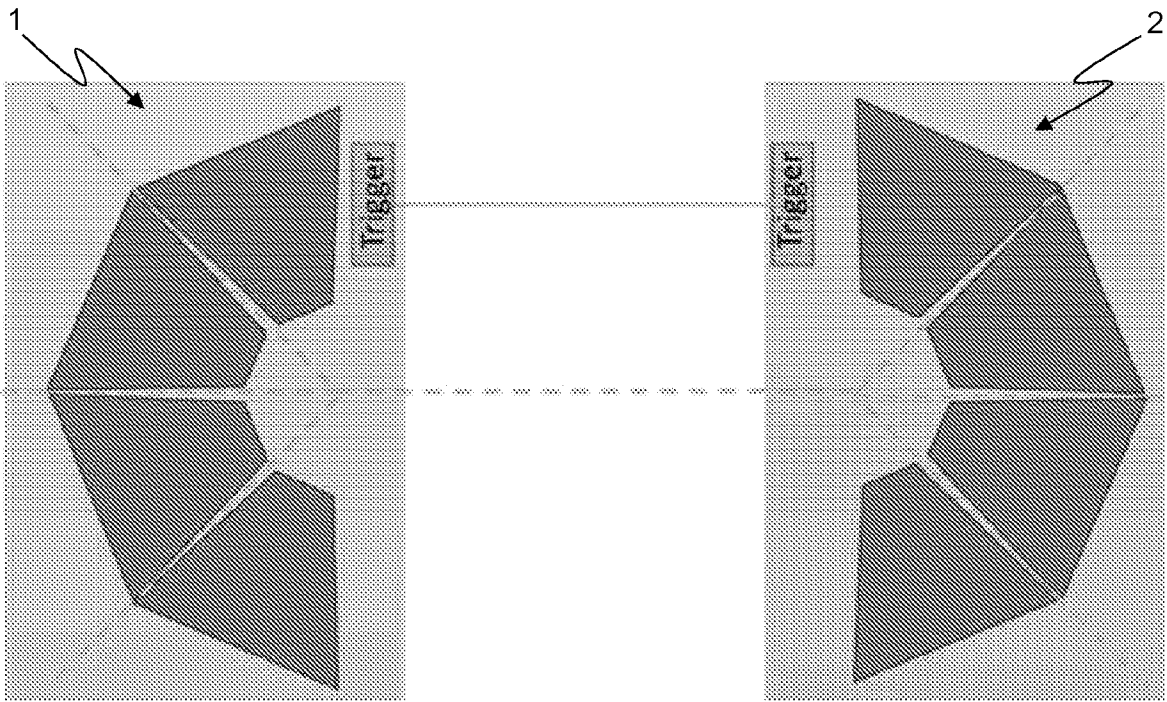

Fig. 1

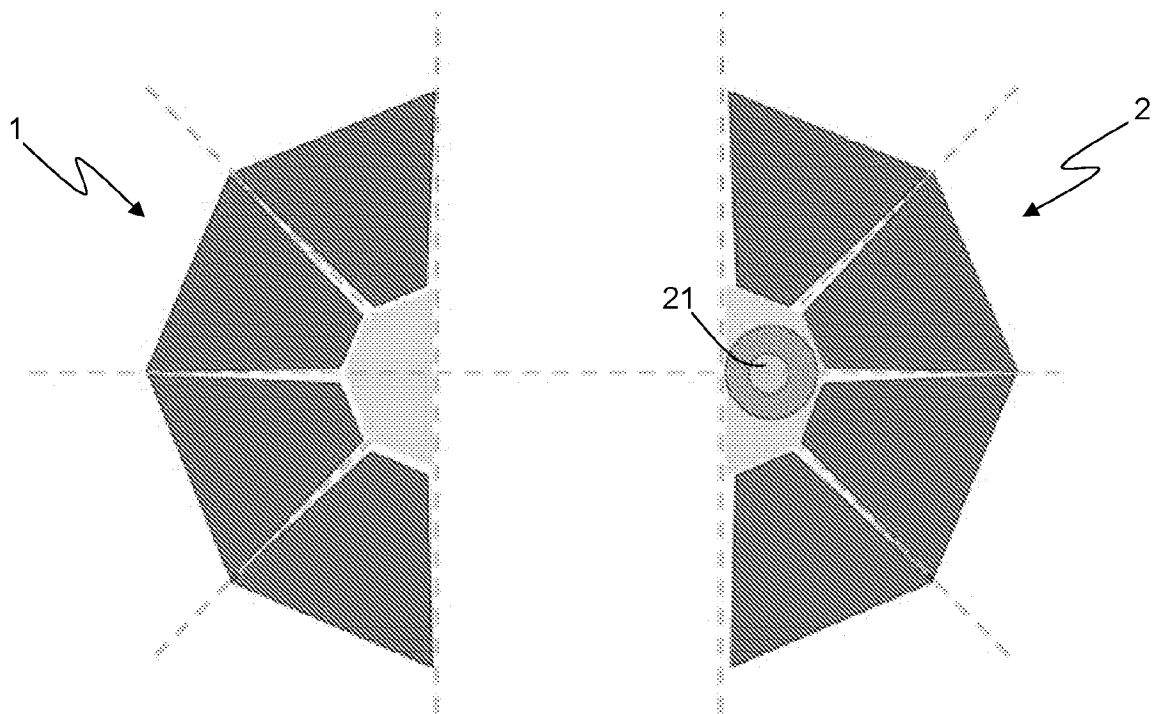

Fig. 2

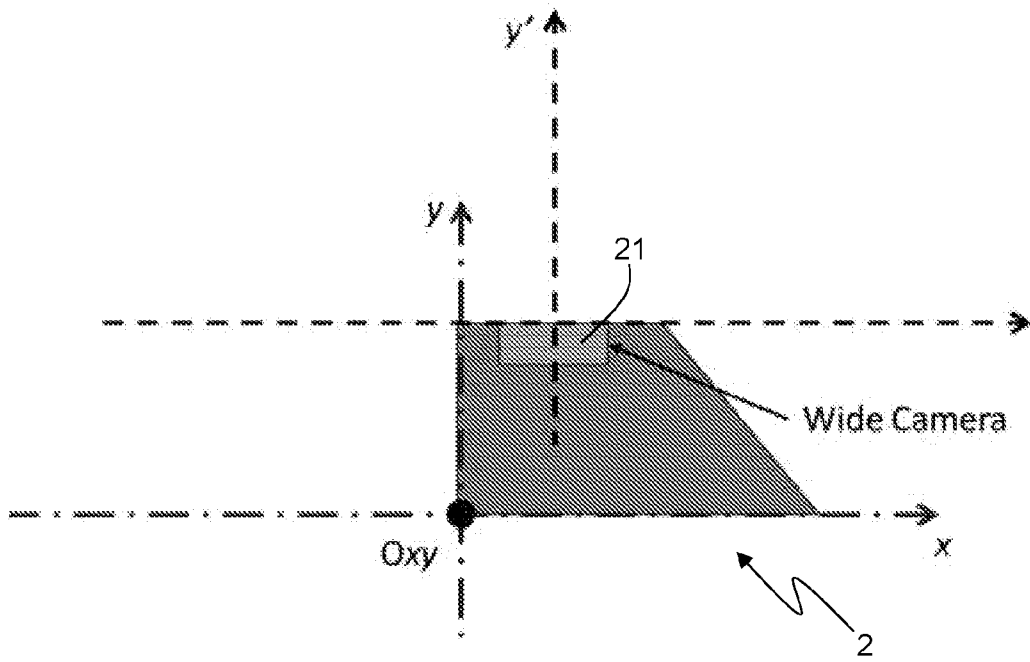

Fig. 3

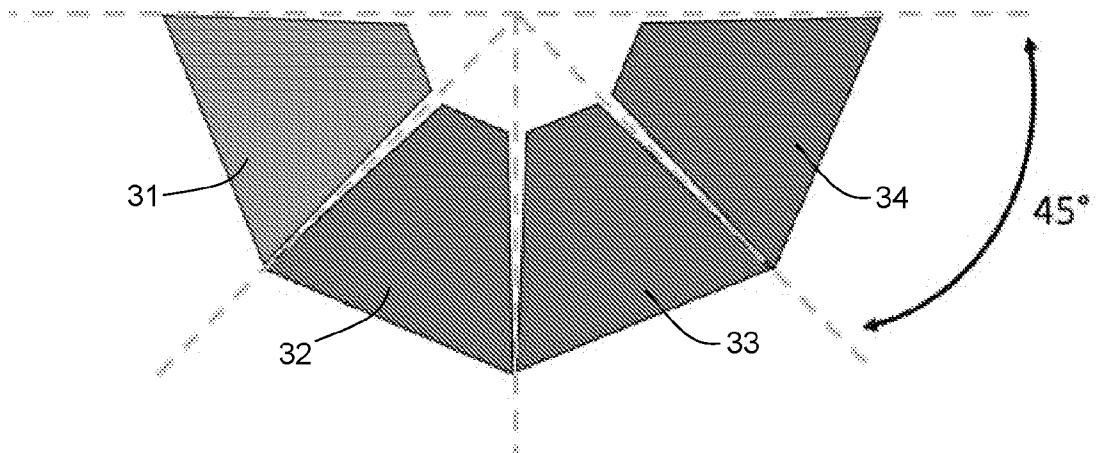

Fig. 4

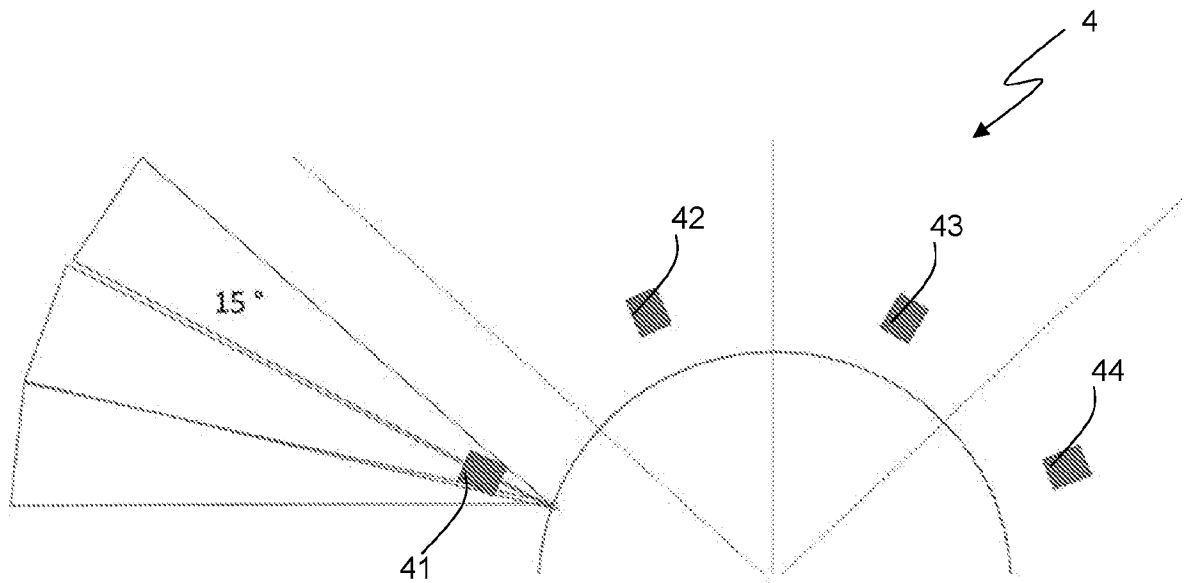

Fig. 5

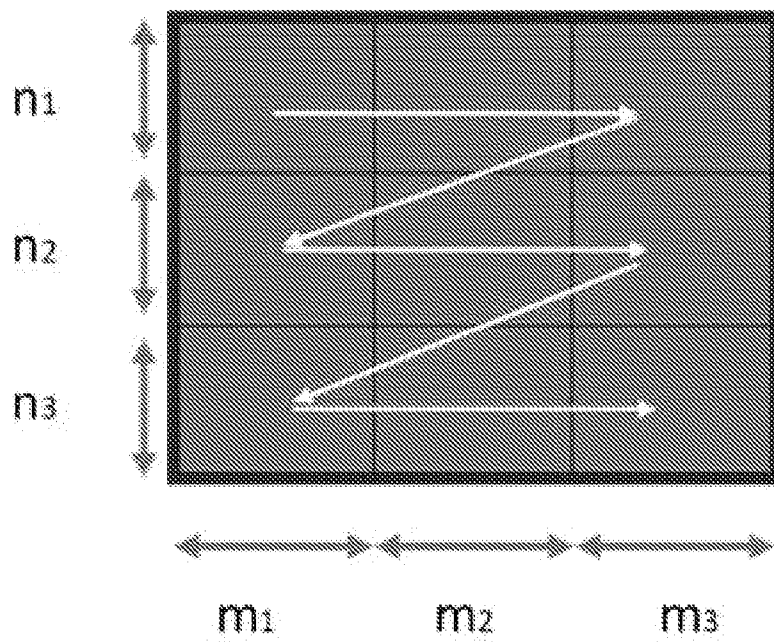

Fig. 7

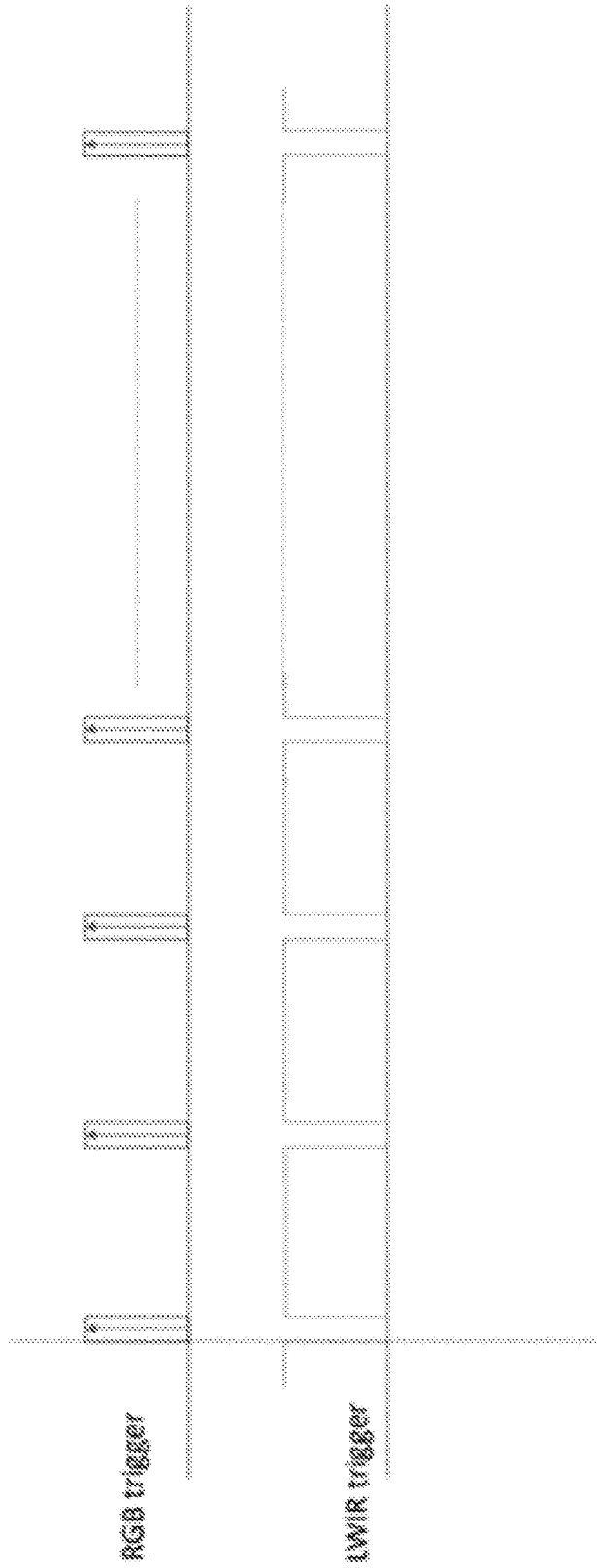

Fig. 6

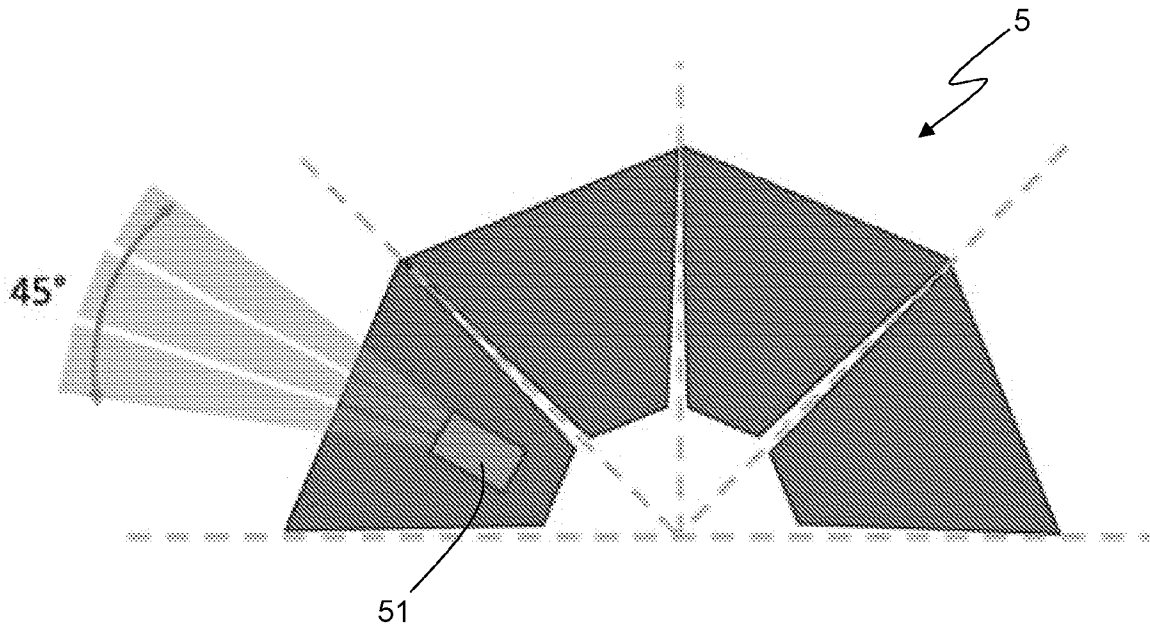

Fig. 8

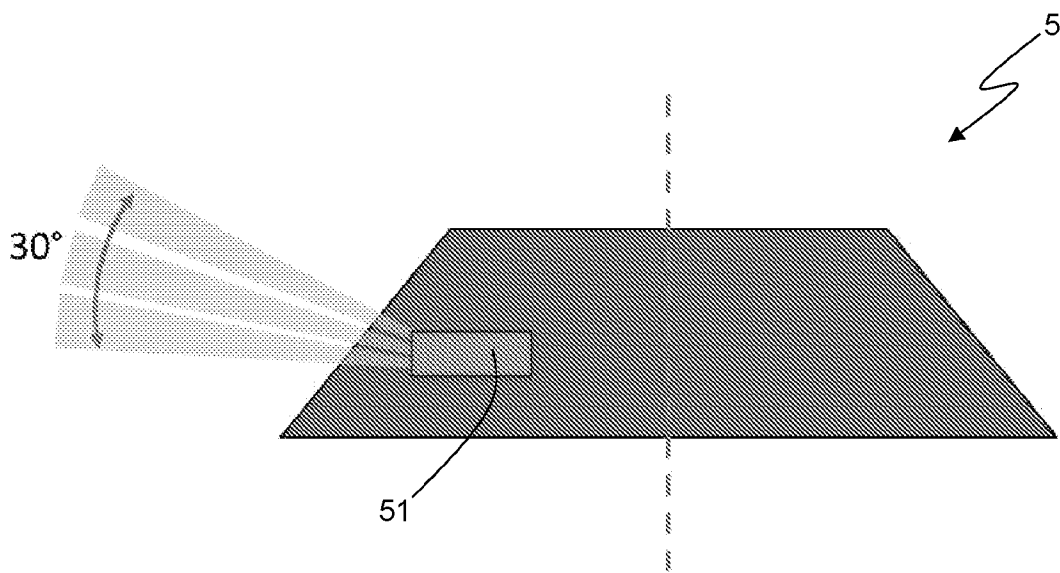

Fig. 9

INTERNATIONAL SEARCH REPORT

International application No PCT/IB2024/059239

A. CLASSIFICATION OF SUBJECT MATTER
 INV. H04N23/698 H04N23/45 H04N23/58 H04N23/90
 ADD.

According to International Patent Classification (IPC) or to both national classification and IPC

B. FIELDS SEARCHED
 Minimum documentation searched (classification system followed by classification symbols)
H04N G06V

Documentation searched other than minimum documentation to the extent that such documents are included in the fields searched

Electronic data base consulted during the international search (name of data base and, where practicable, search terms used)
EPO-Internal, WPI Data

C. DOCUMENTS CONSIDERED TO BE RELEVANT

Category*	Citation of document, with indication, where appropriate, of the relevant passages	Relevant to claim No.
Y	<p>Janeth Ann ET AL: "Anti-Drone System: A Visual-based Drone Detection using Neural Networks",</p> <p style="text-align: center;">,</p> <p>1 January 2020 (2020-01-01), XP093233012, Retrieved from the Internet: URL:https://ieeexplore.ieee.org/stampPDF/getPDF.jsp?tp=&arnumber=9289397&ref=aHR0cHM6Ly9pZWVleHBSb3JlLm1lZWUub3JnL2RvY3VtZW50LzkyODkzOTc= conclusion</p> <p style="text-align: center;">-----</p> <p style="text-align: center;">- / - -</p>	1-3,5-9

<input checked="" type="checkbox"/> Further documents are listed in the continuation of Box C.	<input checked="" type="checkbox"/> See patent family annex.
--	--

* Special categories of cited documents :

<p>"A" document defining the general state of the art which is not considered to be of particular relevance</p> <p>"E" earlier application or patent but published on or after the international filing date</p> <p>"L" document which may throw doubts on priority claim(s) or which is cited to establish the publication date of another citation or other special reason (as specified)</p> <p>"O" document referring to an oral disclosure, use, exhibition or other means</p> <p>"P" document published prior to the international filing date but later than the priority date claimed</p>	<p>"T" later document published after the international filing date or priority date and not in conflict with the application but cited to understand the principle or theory underlying the invention</p> <p>"X" document of particular relevance; the claimed invention cannot be considered novel or cannot be considered to involve an inventive step when the document is taken alone</p> <p>"Y" document of particular relevance; the claimed invention cannot be considered to involve an inventive step when the document is combined with one or more other such documents, such combination being obvious to a person skilled in the art</p> <p>"&" document member of the same patent family</p>
---	---

Date of the actual completion of the international search 11 December 2024	Date of mailing of the international search report 14/01/2025
--	---

Name and mailing address of the ISA/ European Patent Office, P.B. 5818 Patentlaan 2 NL - 2280 HV Rijswijk Tel. (+31-70) 340-2040, Fax: (+31-70) 340-3016	Authorized officer Rolet, Etienne
--	---

INTERNATIONAL SEARCH REPORT

International application No
PCT/IB2024/059239

C(Continuation). DOCUMENTS CONSIDERED TO BE RELEVANT		
Category*	Citation of document, with indication, where appropriate, of the relevant passages	Relevant to claim No.
Y	<p>RAED ABU ZITAR ET AL: "A review of UAV Visual Detection and Tracking Methods", ARXIV.ORG, CORNELL UNIVERSITY LIBRARY, 201 OLIN LIBRARY CORNELL UNIVERSITY ITHACA, NY 14853, 8 June 2023 (2023-06-08), XP091532812, section 3</p> <p style="text-align: center;">-----</p>	1-3,5-9
Y	<p>WO 2022/172217 A1 (DEVAKI KAMALAKAR [IN]; FERNANDES JESUDAS VICTOR [IN]) 18 August 2022 (2022-08-18) p. 18, 2nd and third paragraphs; claims 1,3</p> <p style="text-align: center;">-----</p>	1-9
Y	<p>US 2021/227105 A1 (DAVENEL ARNAUD [FR] ET AL) 22 July 2021 (2021-07-22) paragraphs [0001], [0002], [0006], [0012], [0014], [0032], [0034], [0041], [0052], [0061]; figure 1</p> <p style="text-align: center;">-----</p>	1-9
A	<p>US 2015/373262 A1 (GEORGIEV TODOR GEORGIEV [US] ET AL) 24 December 2015 (2015-12-24) paragraphs [0038], [0041]; figure 1B</p> <p style="text-align: center;">-----</p>	1-7

INTERNATIONAL SEARCH REPORT

Information on patent family members

International application No

PCT/IB2024/059239

Patent document cited in search report	Publication date	Patent family member(s)	Publication date
WO 2022172217	A1	18-08-2022	NONE

US 2021227105	A1	22-07-2021	AU 2019287350 A1 10-12-2020
			CA 3101105 A1 19-12-2019
			EP 3808075 A1 21-04-2021
			FR 3082690 A1 20-12-2019
			IL 279317 A 31-01-2021
			US 2021227105 A1 22-07-2021
			WO 2019238949 A1 19-12-2019

US 2015373262	A1	24-12-2015	BR 112016029714 A2 22-08-2017
			CA 2949550 A1 23-12-2015
			CN 106415386 A 15-02-2017
			EP 3158395 A2 26-04-2017
			JP 6672185 B2 25-03-2020
			JP 2017524976 A 31-08-2017
			KR 20170020789 A 24-02-2017
			US 2015373262 A1 24-12-2015
			US 2016198087 A1 07-07-2016
			WO 2015195297 A2 23-12-2015
