

[54] PROJECTION FILAMENT LAMP

[72] Inventor: Ferdinandus Maria Josephus Van Beek, Emmasingel, Eindhoven, Netherlands

[73] Assignee: U.S. Philips Corporation, New York, N.Y.

[22] Filed: Feb. 9, 1971

[21] Appl. No.: 113,876

[30] Foreign Application Priority Data

Feb. 18, 1970 Netherlands .....7002305

[52] U.S. Cl. ....313/222, 313/269, 313/275, 313/285

[51] Int. Cl. ....H01k

[58] Field of Search.....313/219, 222, 271, 275, 276, 313/277, 284, 285

[56] References Cited

UNITED STATES PATENTS

2,404,992	7/1946	Stone.....	313/271 X
2,226,281	12/1940	Ewing.....	313/271

Primary Examiner—Roy Lake  
Assistant Examiner—James B. Mullins  
Attorney—Frank R. Trifari

[57] ABSTRACT

An electric filament lamp for projection purposes in which the two straight ends of the filament body are incorporated in a pinch seal and are each surrounded by a member supporting said ends; said members are preferably constructed as helically wound wires of unequal lengths and are incorporated at their ends in the pinch seal.

4 Claims, 1 Drawing Figure

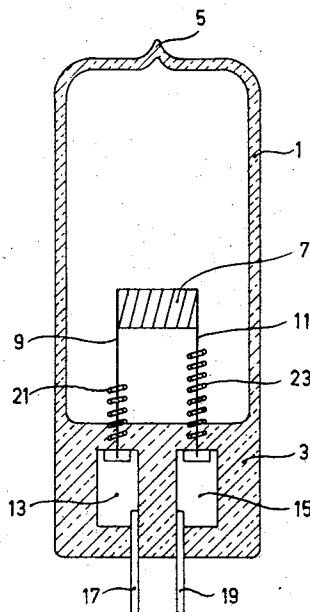

PATENTED DEC 19 1972

3,706,900

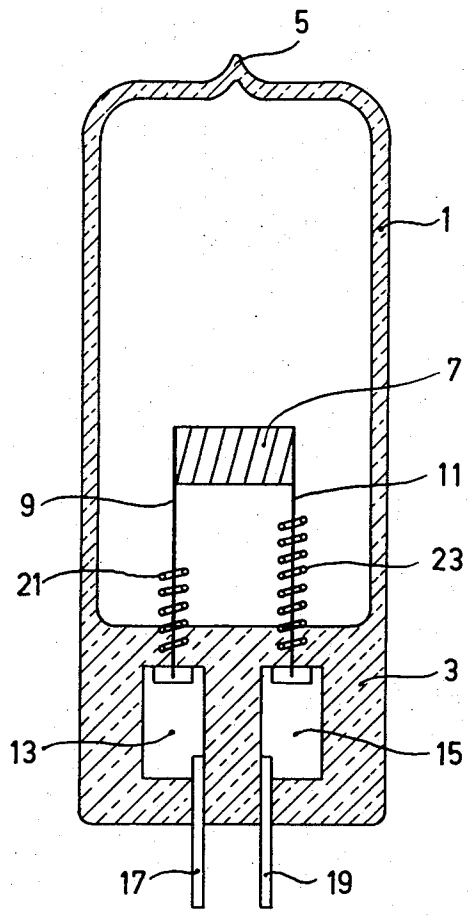

INVENTOR.

FERDINANDUS M. J. VAN BEEK

BY

*Frank R. Jansen*

AGENT

PROJECTION FILAMENT LAMP

The invention relates to an electric filament lamp, in particular a halogen projection lamp, in which the current supply conductors of the filament arranged at right angles to the longitudinal direction of the lamp are secured in a pinch seal present at one end of the lamp, each of the conductors being surrounded by a member which supports said conductors and is incorporated at its one end in the pinched seal and is situated at its other end in the lamp space. Such a filament lamp is known from the U.S. Pat. specification No. 3,470,410.

In the known filament lamp which is constructed as a mono-pinch halogen filament lamp, the two single-coiled current supply conductors which are connected to a coiled-coil filament are each surrounded by helically wound supportings spiral of equal lengths which are incorporated at their one end in the pinch seal and project in the lamp space at their other end. As a result of this, a flexible support of the conductors and a reasonable resistance of the lamps against shocks and vibrations is obtained in a direction transverse to the longitudinal direction of the lamp.

It has now been found that the resistance to shocks and vibrations of the known lamp is considerably improved, if according to the invention the two supporting members, which are preferably also constructed as helically wound wires, project in the lamp space over mutually unequal distances. This is probably due to the fact that in a lamp having supporting members of unequal lengths, fewer resonance deformations occur than in a lamp in which the supporting members are equally long. It has also been surprisingly found that the light arc which upon fusing of a lamp is formed between two fusing conductors, is extinguished sooner when the conductors have mutually unequal lengths.

It has been found experimentally that the best results are obtained when the shorter supporting member is given a length between 20 and 90 percent of the length of the longer supporting member.

In order that the invention may be readily carried into effect, it will now be briefly described in detail with reference to the accompanying drawing, the sole FIGURE of which shows a halogen filament lamp for projection purposes.

This lamp comprises a tubular envelope 1, which is closed at one end by a pinch seal 3 and at its other end by an exhaust tube the tipped-off residue of which is

shown at 5.

Reference numeral 7 denotes a tungsten flattened filament viewed against the largest face thereof. The straight ends 9 and 11 of said elements are incorporated in the pinch seal and secured to foils 13 and 15 of molybdenum. 17 and 19 denote external conductors secured to the foils 13 and 15.

The filament lamp shown comprises two helically wound supporting members 21 and 23 surrounding the ends 9 and 11. These supporting members are also incorporated each at one of their ends in the pinch seal, and extend to the immediate proximity of the foils. They have mutual unequal dimensions of length.

It has been found that, as a result of the choice of said unequal dimensions, the resistance to vibrations and shocks of said lamps is greater than could be reached, for example, when two supporting members of equal length would be chosen.

In the embodiment shown for a 42 Volt-500 Watt lamp, the length of the member 21 is 5.5 mm and that of the member 23 is 10 mm. Both members are formed as helically wound wires of tungsten having a diameter of 100/um. They surround the straight ends 9 and 11, which have a diameter of 120 mm, with a clearance of approximately 0.1 mm.

What is claimed is:

1. An electric filament lamp, in particular a halogen projection lamp, in which the current supply conductors of the filament arranged at right angles to the longitudinal direction of the lamp are secured in a pinch seal present at one end of the lamp, each of the conductors being surrounded by a member which supports said conductors and is incorporated at its one end in the pinched seal and is located at its other end in the lamp space, wherein the members supporting the relative conductors have unequal lengths calculated from the pinch seal.

2. An electric filament lamp as claimed in claim 1, wherein the shorter member has a length which is between 20 and 90 percent of the length of the longer member.

3. An electric filament lamp as claimed in claim 1 or 2, wherein each member surrounds the associated current conductor with some clearance.

4. An electric filament lamp as claimed in claim 1, wherein the member is formed as a helically wound body.

\* \* \* \* \*

50

55

60

65

UNITED STATES PATENT OFFICE  
CERTIFICATE OF CORRECTION

Patent No. 3706900 Dated December 19, 1972

Inventor(s) FERDINANDUS MARIA JOSEPHUS VAN BEEK

It is certified that error appears in the above-identified patent and that said Letters Patent are hereby corrected as shown below:

Column 2, lines 42-43, in Claim 3 cancel "or 2,".

Signed and sealed this 22nd day of May 1973.

(SEAL)  
Attest:

EDWARD M. FLETCHER, JR.  
Attesting Officer

ROBERT GOTTSCHALK  
Commissioner of Patents