



- (51) International Patent Classification: E21B 17/06 (2006.01) E21B 17/02 (2006.01) 15995 North Barkers Landing, Suite 350, Houston, Texas 77079 (US).
- (21) International Application Number: PCT/US2012/035335 (72) Inventor; and (71) Applicant : WHIDDON, Richard Murray [US/US]; 26507 Clear Mill Lane, Houston, Texas 77494 (US).
- (22) International Filing Date: 27 April 2012 (27.04.2012) (74) Agents: FORINASH, Derek V. et al.; Edmonds & Nolte, PC, 10411 Westheimer Road, Suite 201, Houston, Texas 77042 (US).
- (25) Filing Language: English
- (26) Publication Language: English
- (30) Priority Data: 13/096,857 28 April 2011 (28.04.2011) US (81) Designated States (unless otherwise indicated, for every kind of national protection available): AE, AG, AL, AM, AO, AT, AU, AZ, BA, BB, BG, BH, BR, BW, BY, BZ, CA, CH, CL, CN, CO, CR, CU, CZ, DE, DK, DM, DO, DZ, EC, EE, EG, ES, FI, GB, GD, GE, GH, GM, GT, HN, HR, HU, ID, IL, IN, IS, JP, KE, KG, KM, KN, KP, KR, KZ, LA, LC, LK, LR, LS, LT, LU, LY, MA, MD, ME,
- (71) Applicant (for all designated States except US): ENVENTURE GLOBAL TECHNOLOGY, LLC [US/US];

[Continued on next page]

(54) Title: DOWNHOLE RELEASE JOINT

(57) Abstract: An apparatus comprises a support member operable to be disposed within a tubular member that includes a threaded connection with a pin member. The tubular member is coupled to an expansion device that is operable to radially expand the tubular member and a pin catcher that is operable to engage the pin member as the expansion device and pin catcher move axially through the tubular member.



WO 2012/149241 A2

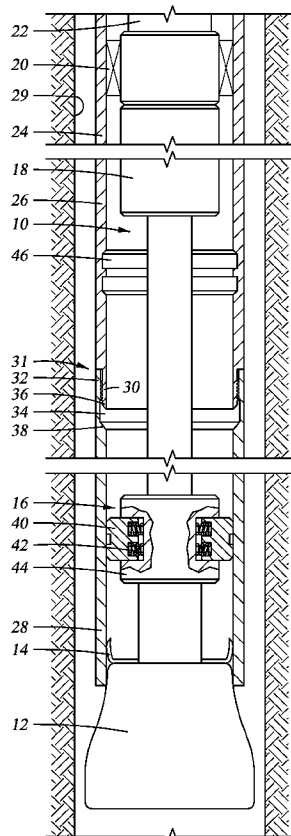

Fig. 1

MG, MK, MN, MW, MX, MY, MZ, NA, NG, NI, NO, NZ, OM, PE, PG, PH, PL, PT, QA, RO, RS, RU, RW, SC, SD, SE, SG, SK, SL, SM, ST, SV, SY, TH, TJ, TM, TN, TR, TT, TZ, UA, UG, US, UZ, VC, VN, ZA, ZM, ZW.

TM), European (AL, AT, BE, BG, CH, CY, CZ, DE, DK, EE, ES, FI, FR, GB, GR, HR, HU, IE, IS, IT, LT, LU, LV, MC, MK, MT, NL, NO, PL, PT, RO, RS, SE, SI, SK, SM, TR), OAPI (BF, BJ, CF, CG, CI, CM, GA, GN, GQ, GW, ML, MR, NE, SN, TD, TG).

**(84) Designated States** (*unless otherwise indicated, for every kind of regional protection available*): ARIPO (BW, GH, GM, KE, LR, LS, MW, MZ, NA, RW, SD, SL, SZ, TZ, UG, ZM, ZW), Eurasian (AM, AZ, BY, KG, KZ, RU, TJ,

**Published:**

— *without international search report and to be republished upon receipt of that report (Rule 48.2(g))*

## CROSS-REFERENCE TO RELATED APPLICATIONS

[0001] This application claims priority to U.S. Patent Application having Serial No. 13/096,857, filed April 28, 2011. This priority application is incorporated herein in its entirety, to the extent consistent with the present application.

## BACKGROUND

[0002] This disclosure relates generally to hydrocarbon exploration and production, and in particular to forming wellbore tubular strings and connections to facilitate hydrocarbon production or downhole fluid injection.

[0003] During hydrocarbon exploration and production, a wellbore typically traverses a number of zones within a subterranean formation. A tubular system may be established in the wellbore to create flow paths between the multiple producing zones and the surface of the wellbore. Efficient completion of the wellbore or production from the surrounding formation is highly dependent on the inner diameter of the tubular system installed in the wellbore. The inner diameter of the tubular system determines the maximum size of equipment that can be installed in the well and the volume of fluids that can flow through the well.

[0004] Expandable tubing may be used to increase the inner diameter of casing, liners and other similar downhole tubular strings used as described above. To create a casing, for example, a tubular member is installed in a wellbore and subsequently expanded by displacing an expansion device through the tubular member. The expansion device may be pushed or pulled using mechanical means, such as by a support tubular coupled thereto, or driven by hydraulic pressure. As the expansion device is displaced axially within the tubular member, the expansion device imparts radial force to the inner surface of the tubular member. In response to the radial force, the tubular member plastically deforms, thereby permanently increasing both its inner and outer diameters. In other words, the tubular member expands radially. In certain operations, expandable tubulars may be used to repair, seal, or remediate existing casing that has been perforated, parted, corroded, or damaged since installation.

[0005] In some circumstances, after the radial expansion and plastic deformation process, the expansion tools and any other tools associated therewith may need to be removed to the surface of the wellbore. Some operations include a separate trip into the wellbore, wherein a retrieval tool is lowered and coupled to the expansion tools for retrieval to the surface. In other operations, the upper unexpanded tubular string and the tools coupled thereto are separated from the lower expanded and installed tubular string for removal to the surface. To separate the unexpanded tubular string from the expanded tubular string, a cutter is used. A casing cutter may be part of the initial tool string such that the casing may be cut without an additional trip. However, the cutter

operation is time-consuming and creates collateral damage to the casing. Therefore, in certain operations, utilized a casing cutter may not be acceptable.

[0006] There remains a need in the art for providing a reliable, simple apparatus and process for releasing a section of expanded tubing from unexpanded tubing. The principles of the present disclosure are directed to overcoming one or more of the limitations of the existing apparatus and processes for separating expanded tubing from unexpanded tubing and associated tools.

#### BRIEF DESCRIPTION OF THE DRAWINGS

[0007] For a more detailed description of the embodiments of the present disclosure, reference will now be made to the accompanying drawings, wherein:

[0008] Figure 1 is a fragmentary cross-sectional illustration of an apparatus for installing an expandable tubular member;

[0009] Figure 2 is a fragmentary cross-sectional illustration of the apparatus of Figure 1 after partially expanding the expandable tubular member;

[0010] Figure 3 is a fragmentary cross-sectional illustration of the apparatus of Figure 1 after further expanding the expandable tubular member;

[0011] Figure 4 is a partial schematic side view of one embodiment of a pin catcher;

[0012] Figure 5 is a partial schematic top view of the pin catcher of Figure 4;

[0013] Figure 6 is a partial schematic view of the pin catcher of Figure 4 engaged with a pin member;

[0014] Figure 7 is a partial schematic side view of an alternate embodiment of a pin catcher;

[0015] Figure 8 is a partial schematic view of the pin catcher of Figure 7 engaged with a pin member;

[0016] Figure 9 is a fragmentary cross-sectional illustration of an alternate apparatus for installing an expandable tubular member;

[0017] Figure 10 is a fragmentary cross-sectional illustration of the apparatus of Figure 1 after partially expanding the expandable tubular member; and

[0018] Figure 11 is a fragmentary cross-sectional illustration of the apparatus of Figure 1 after further expanding the expandable tubular member.

#### DETAILED DESCRIPTION

[0019] It is to be understood that the following disclosure describes several exemplary embodiments for implementing different features, structures, or functions of the invention. Exemplary embodiments of components, arrangements, and configurations are described below to simplify the present disclosure; however, these exemplary embodiments are provided merely as examples and are not intended to limit the scope of the invention. Additionally, the present disclosure may repeat reference numerals and/or letters in the various exemplary embodiments and

across the Figures provided herein. This repetition is for the purpose of simplicity and clarity and does not in itself dictate a relationship between the various exemplary embodiments and/or configurations discussed in the various Figures. Moreover, the formation of a first feature over or on a second feature in the description that follows may include embodiments in which the first and second features are formed in direct contact, and may also include embodiments in which additional features may be formed interposing the first and second features, such that the first and second features may not be in direct contact. Finally, the exemplary embodiments presented below may be combined in any combination of ways, *i.e.*, any element from one exemplary embodiment may be used in any other exemplary embodiment, without departing from the scope of the disclosure.

[0020] Additionally, certain terms are used throughout the following description and claims to refer to particular components. As one skilled in the art will appreciate, various entities may refer to the same component by different names, and as such, the naming convention for the elements described herein is not intended to limit the scope of the invention, unless otherwise specifically defined herein. Further, the naming convention used herein is not intended to distinguish between components that differ in name but not function. Additionally, in the following discussion and in the claims, the terms "including" and "comprising" are used in an open-ended fashion, and thus should be interpreted to mean "including, but not limited to." All numerical values in this disclosure may be exact or approximate values unless otherwise specifically stated. Accordingly, various embodiments of the disclosure may deviate from the numbers, values, and ranges disclosed herein without departing from the intended scope. Furthermore, as it is used in the claims or specification, the term "or" is intended to encompass both exclusive and inclusive cases, *i.e.*, "A or B" is intended to be synonymous with "at least one of A and B," unless otherwise expressly specified herein.

[0021] Referring initially to Figure 1, expansion assembly 10 comprises expansion device 12, pin catcher 14, latch assembly 16, actuator 18, and anchor 20 coupled to support member 22. Expansion assembly 10 is disposed within tubular member 24. Tubular member 24 and expansion assembly 10 are disposed in wellbore 29. Tubular member 24 is an expandable tubular made up of upper tubular member 26 and lower tubular member 28. Upper tubular member 26 and lower tubular member 28 may each be constructed of a plurality of tubular members joined together by threaded connections or other means, such as welding or brazing.

[0022] Lower tubular member 28 is the portion of tubular member 24 that will be expanded and left in wellbore 29. Upper tubular member 26 is the portion of tubular member 24 that will not be expanded and will be retrieved along with expansion assembly 10. The junction between upper tubular member 26 and lower tubular member 28 is defined by releasable connection 31.

Releasable connection 31 is formed by threadably engaging pin member 30 of upper tubular member 26 and box member 32 of lower tubular member 28.

[0023] In order to properly function, releasable connection 31 must disconnect as lower tubular member 28 is expanded but before upper tubular member 26 is expanded. Radial expansion of upper tubular member 26 is preferably minimized so as to ensure removal of the upper tubular member from wellbore 29. The disconnection of releasable connection 31 without expansion of upper tubular member 26 may be complicated by the interaction of pin member 30 and box member 32. As lower tubular member 28 and box member 32 are radially expanded, the threaded engagement of pin member 30 and the box member may not immediately separate. This resistance to separation may result in pin member 30 being radially expanded by the expansion of box member 32. In order to reduce or eliminate this interaction, pin catcher 14 is provided to facilitate the separation of pin member 30 from box member 32 by reducing or eliminating the ability of the pin member to radially expand.

[0024] When releasable connection 31 is formed, gap 34 remains between end 36 of pin member 30 and base 38 of box member 32. Gap 34 is sized to allow engagement of pin catcher 14 but prevent engagement of latch assembly 16. As will be discussed in detail to follow, pin catcher 14 enters gap 34 and engages pin member 30. This engagement reduces the radial expansion of pin member 30 by either holding pin end 36 in place or deflecting the pin end inward, thus aiding the separation of pin member 30 from box member 32. In certain embodiments, pin member 30 may have longitudinal slots or other features that reduce the force required to deflect the pin member inward.

[0025] Once releasable connection 31 is separated, upper tubular member 26 and expansion assembly 10 can be removed from the wellbore leaving an expanded lower tubular member 28 in place. To further enhance the expansion process, upper tubular member 26 also includes receptacle 46 that is configured to engage latch assembly 16 after releasable connection 31 has been disconnected. The engagement of latch assembly 16 and receptacle 46 restricts the movement of expansion assembly 10 through upper tubular member 28 and provides a positive stop to the expansion of the upper tubular member.

[0026] Latch assembly 16 comprises a plurality of dogs 40, wherein each dog has one or more biasing members 42 that urge the dog outward. Dogs 40 are contained within housing 44 that prevents axial movement of the dogs relative to support member 22. Receptacle 46 has a profile that accepts dogs 40. Once dogs 40 engage receptacle 46, axial movement of expansion device 12 relative to upper tubular member 28 is restricted. The engagement of latch assembly 16 and receptacle 46 also provides an indication to personnel operating expansion assembly 10 that the expansion of lower tubular member 28 is complete.

[0027] Expansion device 12 may be an expansion cone or other device that radially expands the tubular member as the expansion device is moved axially therethrough. In the embodiment shown in Figures 1-3, expansion device 12 is moved axially through tubular member 24 by engaging the tubular member with anchor 20 and applying an axial force to the expansion device with actuator 18. Anchor 20 is activated to engage tubular member 24 and fix one end of support member 22 to the tubular member. Actuator 18 is then activated to move expansion device 12 relative to anchor 20 and through tubular member 24.

[0028] The movement of expansion device 12 is limited by the "stroke length" of actuator 18. Once actuator 18 has moved expansion device 12 the full "stroke length," anchor 20 can be released. Anchor 20 is then moved upward through tubular member 24 in conjunction actuator 18 being reset. The sequence can then be re-started to continue the expansion process until the predetermined length of tubular has been expanded. Those skilled in the art will understand that other methods, including hydraulic pressure applied directly to expansion device 12 and tension applied to support member 22 from the surface, can be used to move the expansion device through tubular member 24.

[0029] Referring now to Figure 2, the expansion of lower tubular member 28 is substantially complete but releasable connection 31 still couples the lower tubular member to upper tubular member 26. In the position shown, anchor 20 is engaged with upper tubular member 26 and expansion device 12 is disposed within lower tubular member 28. As actuator 18 moves expansion device 12 through lower tubular member, box member 32 begins to expand. Pin catcher 14 is positioned above expansion device 12 so that the pin catcher enters gap 34 and engages pin end 36 as box member 32 begins to expand. Dogs 40 of latch assembly 16 have not yet engaged receptacle 46 so expansion device 12 continues to move through and expand lower tubular member 28 and box member 32.

[0030] Referring now to Figure 3, as upward movement of expansion device 12 continues, lower tubular member 28 and box member 32 are further expanded. Pin member 30 of upper tubular member 26 is retained in pin catcher 14 and is deflected inward. This inward deflection ensures that pin member 30 separates from box member 32 and releasable connection 31 is disconnected. Once releasable connection 31 is disconnected, dogs 40 of latch assembly 16 engage receptacle 46 and couple expansion assembly 10 to upper tubular member 26.

[0031] The disconnection of releasable connection 31 and coupling of expansion assembly 10 and upper tubular member 26 completes the release of the upper tubular member from lower tubular member 28. The coupled upper tubular member 26 and expansion assembly 10 can then be pulled upward as necessary to fully expand the end of lower tubular member 28. Once expansion device 12 is free from lower tubular member 28, upper tubular member 26 and expansion assembly 10

can then be retrieved to the surface, leaving expanded lower tubular member 28 in place in wellbore 29.

[0032] Referring now to Figures 4 and 5, a partial sectional view of one embodiment of pin catcher 14 is shown. Pin catcher 14 comprises base plate 50, hinge 52, engagement arm 54, and spring 56. Base plate 50 is coupled to support member 22. As seen in Figure 5, base plate 50 supports a plurality of engagement arms 54 spaced circumferentially around base plate 50. Engagement arms 54 are arranged so as to provide substantially full circumferential engagement with pin end 36. Therefore, the number and configuration of engagement arms 54 depends on the size of the tubular for which the system is designed.

[0033] Each engagement arm 54 is rotatably coupled to base plate 50 by a hinge 52. Hinge 52 may be a mechanical hinge. In certain embodiments, engagement arms 54 may be integral to base plate 50 and hinge 52 defines the axis about which the engagement arms can rotate. Each engagement arm 54 may have one or more springs 56 are coupled thereto. Springs 56 are also coupled to base plate 50 so as to create a torque about hinge 52 that biases the engagement arm into contact with tubular 24.

[0034] Referring now to Figure 6, as the leading edge of engagement arm 54 enters gap 34, spring 56 rotates the engagement arm outward to an extended position. In the extended position, engagement arm 54 contacts and engages pin end 36 of pin member 30. As pin catcher 14 continues to move through tubular 24, engagement arm 54 facilitates the separation of pin member 30 from box member 32 by either deflecting pin member 30 inward (as shown) or holding the pin member in place while box member 32 is expanded outward.

[0035] Referring now to Figures 7 and 8, pin catcher 58 comprises base plate 60, hinges 62, engagement arms 64, and resilient material 66. Pin catcher 58 is constructed so that resilient material 66 urges engagement arms 64 outward into an extended position contact with tubular 24. In certain embodiments, this may be accomplished by molding resilient material 66 onto pin catcher 58 with engagement arms 64 in the extended position. Engagement arms 64 would have to be rotated inward to fit into tubular member 24, which would compress resilient material 66 creating an outward force on the engagement arms.

[0036] Referring now to Figure 9, expansion assembly 70 comprises expansion device 72, pin catcher assembly 74, and latch assembly 76 coupled to support member 78. Expansion assembly 70 is disposed within tubular member 80. Tubular member 80 and expansion assembly 70 are disposed in wellbore 82. Tubular member 80 is an expandable tubular made up of upper tubular member 84 and lower tubular member 86. Expansion assembly 70 is operable to move axially through tubular member 80 by way of tension applied from the surface, hydraulic pressure, an actuator system as described in reference to Figures 1-3, other means as are known in the art, or

combinations thereof. The axial movement of expansion device 72 through tubular member 80 results in the radial expansion of the tubular member.

[0037] Pin catcher assembly 74 further comprises a plurality of dogs 88 disposed in housing 90 coupled to support member 78. A plurality of biasing members 92 bias pin dogs 88 outward from the centerline of support member 78. Housing 90 limits the axial and radial movement of latch dogs 88 relative to support member 78. Each pin dog 88 has an engagement member 93. Latch assembly 76 comprises a plurality of latch dogs 94, wherein each latch dog has one or more biasing members 96 that urge the latch dog outward. Latch dogs 94 are contained within housing 98 that prevents axial movement of the latch dogs relative to support member 78.

[0038] Upper tubular member 84 and lower tubular member 86 may each be constructed of a plurality of tubular members joined together by threaded connections or other means, such as welding or brazing. The junction between upper tubular member 84 and lower tubular member 86 is defined by releasable connection 100. Releasable connection 100 is formed by threadably engaging pin member 102 of upper tubular member 84 and box member 104 of lower tubular member 86.

[0039] When releasable connection 100 is formed, gap 106 remains between pin member 102 and box member 104. Gap 106 is sized to allow engagement of pin catcher 74 but prevent engagement of latch assembly 76. As will be discussed in detail to follow, pin dogs 88 enter gap 106 and engage pin member 102. In certain embodiments, pin member 102 may have longitudinal slots or other features that reduce the force required to deflect the pin member inward. Upper tubular member 84 also includes receptacle 108 that is configured to accept dogs 94 of latch assembly 76.

[0040] Referring now to Figure 10, the expansion of lower tubular member 86 is substantially complete but releasable connection 100 still couples the lower tubular member to upper tubular member 84. Pin dogs 88 have entered gap 106 and engaged pin member 102 as box member 104 has been expanded. Latch dogs 94 have not yet engaged receptacle 108 so expansion device 72 continues to move through and expand lower tubular member 86 and box member 104.

[0041] Referring now to Figure 11, as upward movement of expansion device 72 continues, lower tubular member 86 and box member 104 are further expanded. Pin member 102 of upper tubular member 84 is retained by pin dogs 88 and is deflected inward. This inward deflection ensures that pin member 102 separates from box member 104 and releasable connection 100 is disconnected. Once releasable connection 100 is disconnected, latch dogs 94 engage receptacle 106 and couple expansion assembly 70 to upper tubular member 84.

[0042] The disconnection of releasable connection 100 and coupling of expansion assembly 70 and upper tubular member 84 completes the release of the upper tubular member from lower tubular member 86. The coupled upper tubular member 84 and expansion assembly 70 can then be pulled upward as necessary to fully expand the end of lower tubular member 86. Once expansion

device 72 is free from lower tubular member 86, upper tubular member 84 and expansion assembly 70 can then be retrieved to the surface, leaving expanded lower tubular member 86 in place in wellbore 82.

[0043] In various embodiments described herein, an apparatus comprises a support member operable to be disposed within a tubular member that includes a threaded connection with a pin member. The tubular member is coupled to an expansion device that is operable to radially expand the tubular member and a pin catcher that is operable to engage the pin member as the expansion device and pin catcher move axially through the tubular member.

[0044] The foregoing has outlined features of several embodiments so that those skilled in the art may better understand the present disclosure. Those skilled in the art should appreciate that they may readily use the present disclosure as a basis for designing or modifying other processes and structures for carrying out the same purposes and/or achieving the same advantages of the embodiments introduced herein. Those skilled in the art should also realize that such equivalent constructions do not depart from the spirit and scope of the present disclosure, and that they may make various changes, substitutions and alterations herein without departing from the spirit and scope of the present disclosure.

1. An apparatus comprising:
  - a support member operable to be disposed within a tubular member, wherein the tubular member includes a threaded connection having a pin member;
  - an expansion device coupled to the support member and operable to radially expand the tubular member as the expansion device moves axially through the tubular member; and
  - a pin catcher coupled to the support member and operable to engage the pin member as the pin catcher moves axially through the tubular member.
  
2. The apparatus of claim 1, wherein the pin catcher further comprises:
  - an engagement member moveable to an extended position where the engagement member engages the pin member; and
  - a biasing member operable to urge the engagement member to the extended position.
  
3. The apparatus of claim 2, wherein the biasing member comprises a spring.
  
4. The apparatus of claim 2, wherein the biasing member comprises a resilient material.
  
5. The apparatus of claim 1, further comprising:
  - a latch assembly coupled to the support member and operable to engage a corresponding latch receptacle disposed within the tubular member, wherein the engagement of the latch assembly and the latch receptacle limits the axial movement of the expansion device relative to the tubular member.
  
6. The apparatus of claim 5 wherein the latch assembly further comprises:
  - a latch housing coupled to the support member;
  - a plurality of dogs disposed within the latch housing; and
  - one or more biasing members operable to bias the plurality of dogs outward into contact with the latch receptacle.
  
7. The apparatus of claim 1, wherein the pin catcher further comprises:
  - a housing coupled to the support member;
  - a plurality of dogs disposed within the housing; and
  - a plurality of biasing members operable to bias the plurality of dogs into engagement with the pin member.

8. A system comprising:
- an upper expandable tubular member having a pin member;
  - a lower expandable tubular member having a box member coupled to the pin member;
  - a support member operable to be disposed within the upper and lower expandable tubular members;
  - an expansion device coupled to the support member and operable to radially expand the tubular member as the expansion device moves axially through the expandable tubular members;
  - and
  - a pin catcher coupled to the support member and operable to engage the pin member as the pin catcher moves axially through the tubular member.
9. The system of claim 8, wherein the pin catcher further comprises:
- an engagement member moveable to an extended position where the engagement member engages the pin member; and
  - a biasing member operable to urge the engagement member to the extended position.
10. The system of claim 9, wherein the biasing member comprises a spring.
11. The system of claim 9, wherein the biasing member comprises a resilient material.
12. The system of claim 8, further comprising:
- a latch assembly coupled to the support member and operable to engage a corresponding latch receptacle disposed within the upper expandable tubular member, wherein the engagement of the latch assembly and the latch receptacle limits the axial movement of the expansion device relative to the upper expandable tubular member.
13. The system of claim 8, wherein the pin catcher further comprises:
- a housing coupled to the support member;
  - a plurality of dogs disposed within the housing; and
  - a plurality of biasing members operable to bias the plurality of dogs into engagement with the pin member..
14. A method comprising:
- coupling an expansion device and a pin catcher to a support member to form an expansion assembly;

disposing the expansion assembly within a tubular member, wherein the tubular member includes a threaded connection having a pin member;

moving the expansion assembly axially through the tubular member, wherein the expansion device radially expands the tubular member and the pin catcher engages the pin member as the expansion assembly moves axially through the tubular member.

15. The method of claim 14, wherein the pin catcher further comprises:
  - an engagement member moveable to an extended position where the engagement member engages the pin member; and
  - a biasing member operable to urge the engagement member to the extended position.
16. The method of claim 15, wherein the biasing member comprises a spring.
17. The method of claim 15, wherein the biasing member comprises a resilient material.
18. The method of claim 14, further comprising:
  - engaging a latch receptacle disposed within the tubular member with a latch assembly that is coupled to the expansion assembly, wherein the engagement of the latch assembly and the latch receptacle limits the axial movement of the expansion device relative to the tubular member.
19. The method of claim 18, wherein the latch assembly further comprises:
  - a latch housing coupled to the support member;
  - a plurality of dogs disposed within the latch housing; and
  - one or more biasing members operable to bias the plurality of dogs outward into contact with the latch receptacle.
20. The method of claim 14, wherein the pin catcher further comprises:
  - a housing coupled to the support member;
  - a plurality of dogs disposed within the housing; and
  - a plurality of biasing members operable to bias the plurality of dogs into engagement with the pin member..



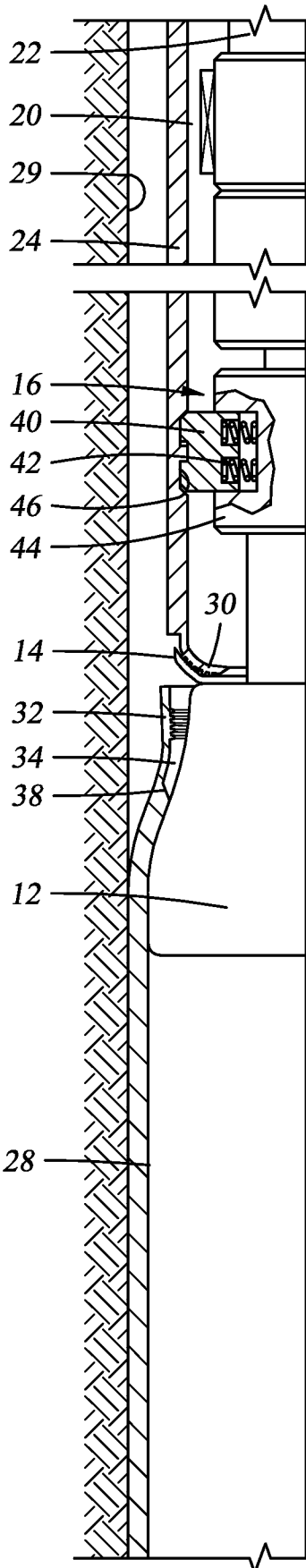

Fig. 3

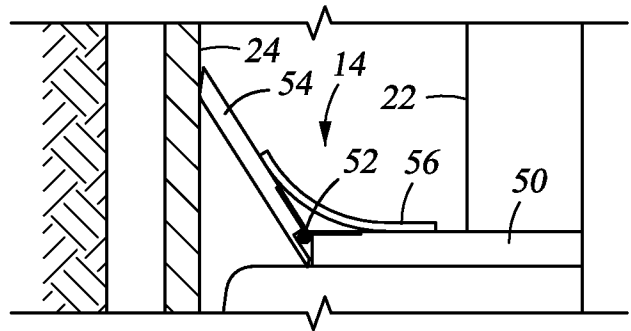

Fig. 4

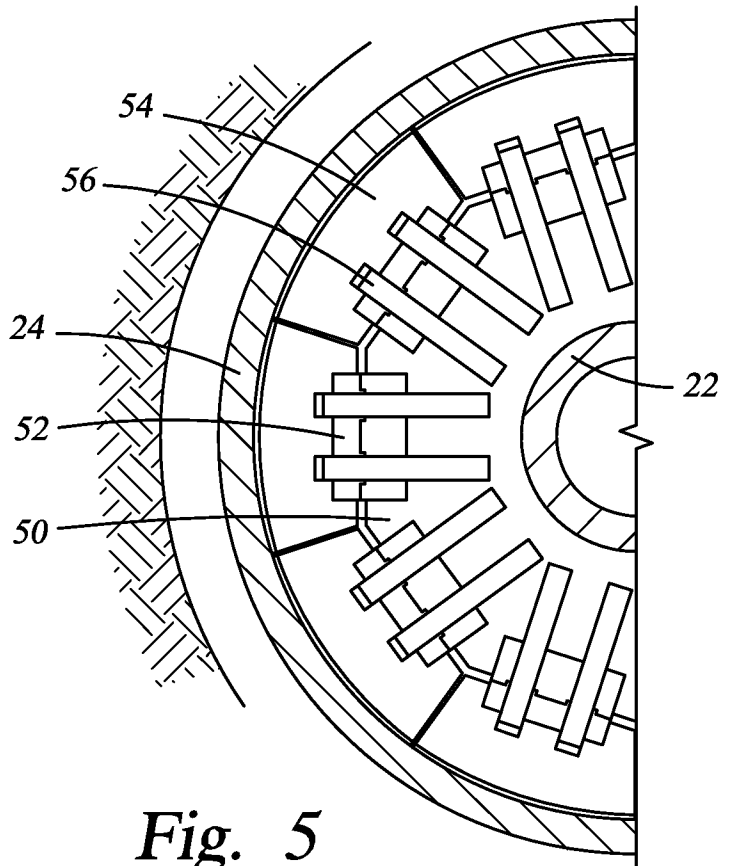

Fig. 5

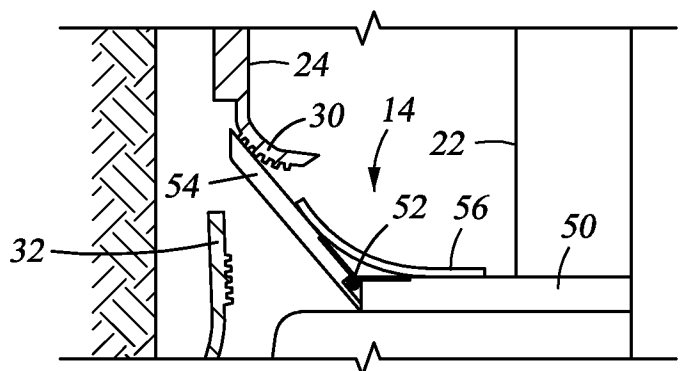

Fig. 6

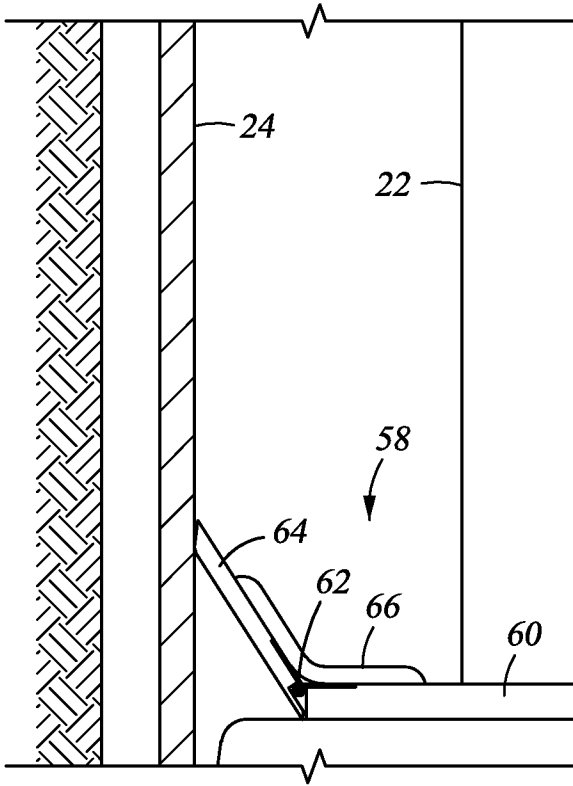

Fig. 7

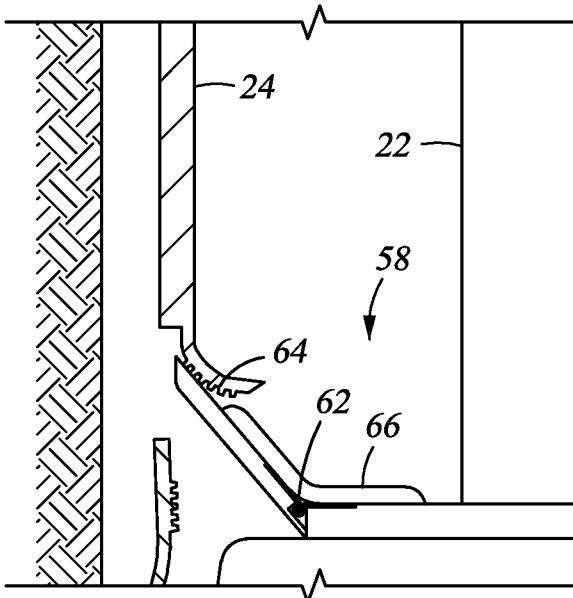

Fig. 8

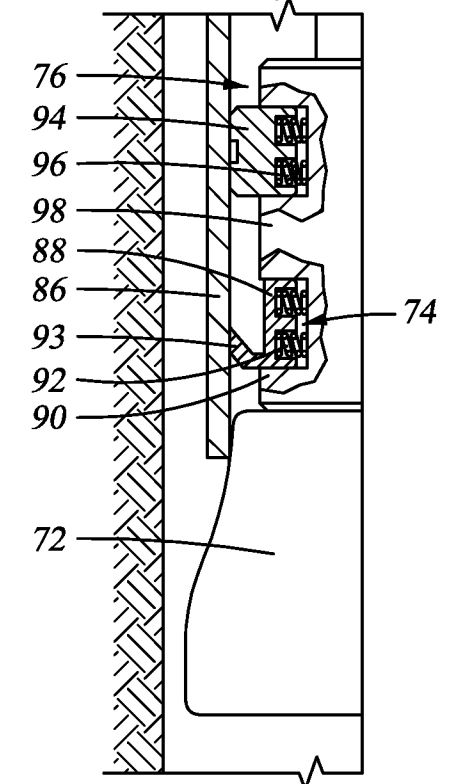
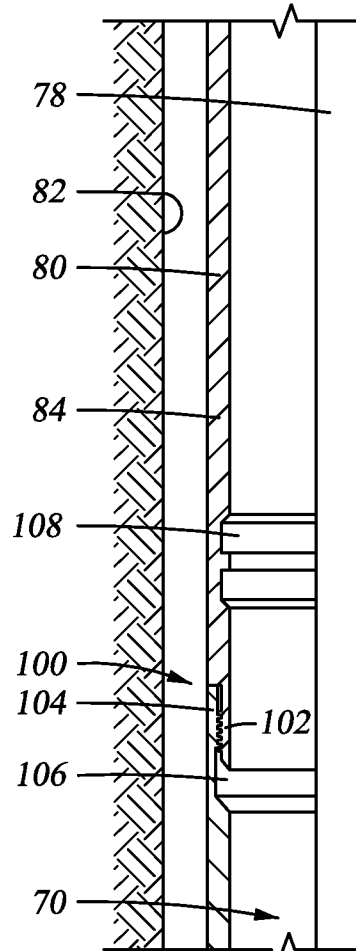

Fig. 9

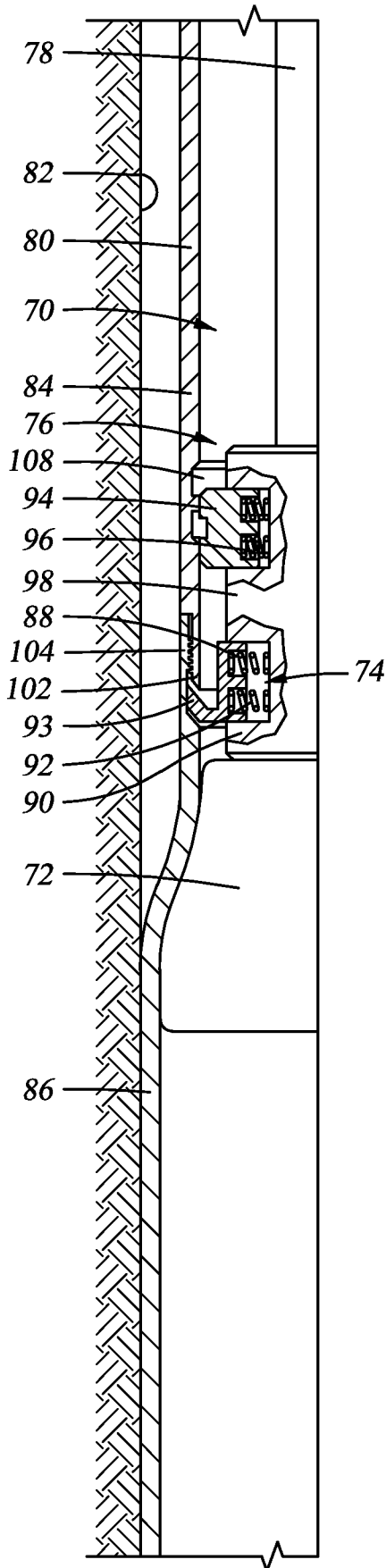

Fig. 10

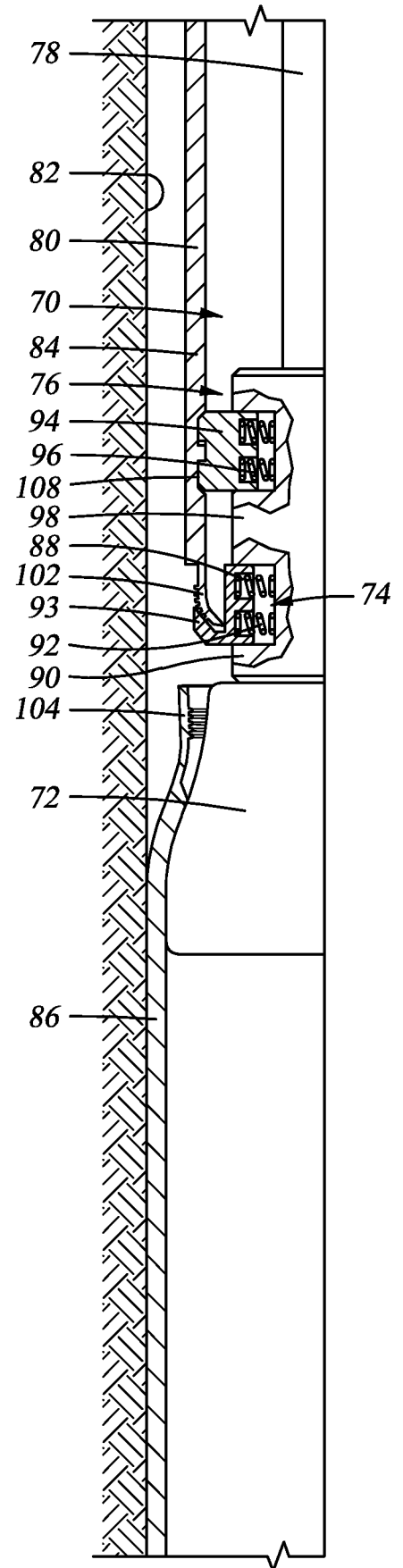

Fig. 11