

Jan. 3, 1961

D. R. LAMMERS

2,967,002

PROTECTIVE TRAY FOR CARTONS

Filed July 2, 1956

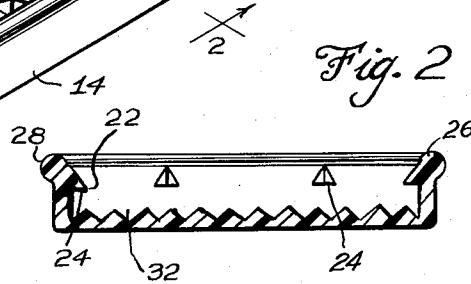
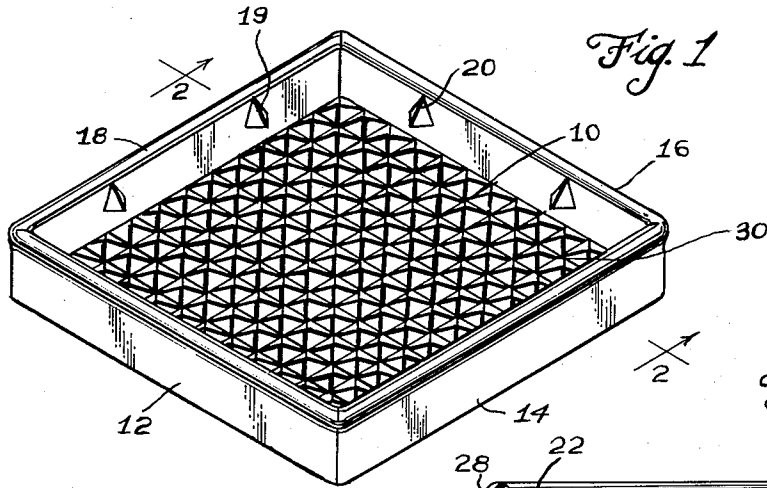

Fig. 3

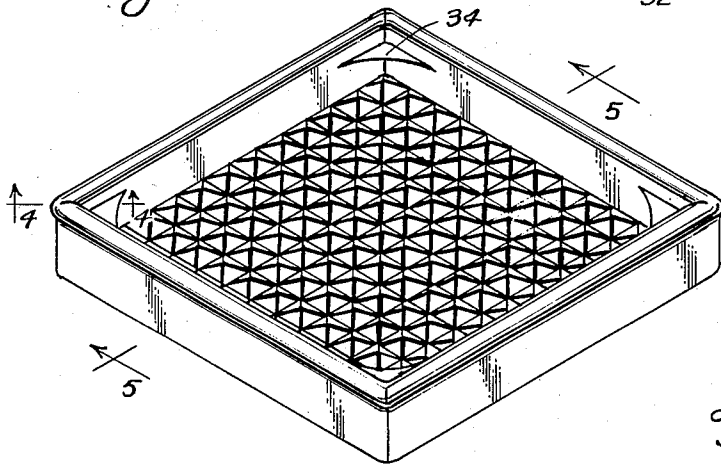

Fig. 5

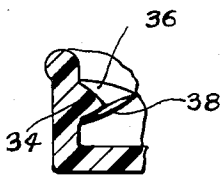

Fig. 4

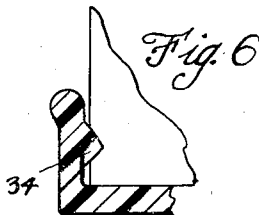

Fig. 6

INVENTOR.
Delmar R. Lammers
BY
Walter R. Harbaugh
Attu.

1

2,967,002

PROTECTIVE TRAY FOR CARTONS

Delmar R. Lammers, 5130 Sherbrook Lane, Peoria, Ill.

Filed July 2, 1956, Ser. No. 595,393

6 Claims. (Cl. 220—85)

This invention relates to protective trays for cartons and more particularly to a protective tray for mounting a carton for milk or the like to prevent contamination of other foods and to provide a receptacle for condensate forming on the exterior surfaces of the carton.

Prior to the present invention, trays have been proposed as receptacles or paperboard cartons of the type commonly used for shipping milk and other edible liquids. In one form of such a device, hemispherical lugs are spaced about the side walls of the tray to engage the lower marginal edges of the carton. A disadvantage of this arrangement is that the curved surfaces of the lugs tend to permit an upward camming action which, due to the flexible nature of the carton sides, results in disengagement of the tray from the carton. In other devices of this type, means are provided for channeling condensate which forms on the side walls into absorbent material at the bottom of the tray. A disadvantage of this construction is that the absorbent material becomes contaminated and is unfit for subsequent use.

With this in mind, a primary object of the invention is to provide a tray of the type described which positively locks on the carton and in which engagement is made in areas free from excessive flexing so that permanent distortion of the carton does not result from the mounting operation.

Another object of the invention is to provide a tray of the stated type in which the carton is cammed into position and in which inadvertent disengagement of the tray is precluded.

Another object of the invention is to provide a tray of the mentioned character which is shaped to conform to the configuration of a rectangular carton and in which means are provided at the corners thereof for locking engagement with the corners of the carton.

A further object of the invention is to provide a tray of the type described having a plurality of recesses for receiving condensate from the bottom wall of the carton by capillary action.

Another object of the invention is to provide a tray of the stated type which is constructed and arranged for efficient and effective mounting of a cardboard carton and which is characterized by ease of manufacture and facility of use.

A final object of the invention is to provide a tray of the type described which is characterized by convenience in form and improved functional characteristics.

Other and further objects, advantages and features of the present invention will be apparent to those skilled in the art from the following description, taken in conjunction with the accompanying drawings in which similar reference characters relate to similar parts and in which:

Fig. 1 is a view in perspective of a tray made in accordance with the present invention;

Fig. 2 is an elevational sectional view taken substantially on line 2—2 of Fig. 1;

Fig. 3 is a view in perspective of a modified form of the present invention;

2

Fig. 4 is an elevational sectional view taken substantially on line 4—4 of Fig. 3;

Fig. 5 is a vertical sectional view taken substantially on line 5—5 of Fig. 3; and

Fig. 6 is a view similar to Fig. 4 but showing the tray in the position it assumes when a carton is mounted in position.

With reference to the drawing and more particularly to Fig. 1, the tray of the present invention comprises essentially a bottom wall 10 and upstanding side walls 12, 14, 16 and 18. Preferably, the tray is desirably formed of a plastic such as polyethylene which may be conveniently molded to conform to the dimensions of a typical milk carton and which has an innate tendency to yield to a limited extent while at the same time maintaining the integrity of its molded form. Because of this characteristic, polyethylene is particularly suitable for the tray of the present invention and, in addition, polyethylene is characterized by a wax-like surface which facilitates the camming action contemplated by the present invention.

In spaced relation to the corners of the side walls are formed pairs of lugs 19 which are semi-pyramidal in construction and, as shown in the drawings, have downwardly and inwardly sloping leading edges 20 which are engaged by the lower edge of the carton and serve as a cam for effecting easy mounting of the carton despite the fact that the lugs 19 protrude inwardly of the inner surfaces of the side walls a distance exceeding the perimeter of the carton with which it is intended to be used. As the carton is cammed into position, the sides thereof are distorted to a limited extent. According to the present invention, this distortion of the carton is minimized by the location of the lugs adjacent the corners of the carton. This is true because the carton has greater resistance to flexing in the corner zones.

According to the present invention also, the lugs 19, as best shown in Fig. 2, are formed to provide a sharp point 22 defined by a shoulder 24. By this arrangement, inadvertent disengagement of the carton and the tray is precluded because of the fact that the point 22 exerts a concentrated frictional engagement with the side walls of the carton. This frictional engagement may only be terminated by intentional permanent distortion of the carton as when the contents are depleted.

Referring now to Fig. 2, the side walls 12, 14, 16 and 18 are flared outwardly as at 26 and are provided at their upper edges with a continuous bead 28. The bead 28 facilitates alignment of the carton with the tray while the flaring of the side wall assures a perimetric channel for reception of condensate from the side walls of the carton. The presence of the lugs 19 in spaced relation to the corners of the tray assures a spacing at all times between the side walls of the carton and the side walls of the tray despite the fact that the side walls of the carton would have a tendency to bulge outwardly. This is true because the central zone of the side walls of the carton would naturally tend to bulge more than the corners and this zone is retained in position by the spacing of the lugs 19 away from the corners of the tray. The bottom wall of the carton normally rests on the bottom wall of the tray. To carry off condensate formed on the bottom of the carton, a plurality of recesses 30 are formed in the top surface of the bottom wall 10 of the tray. Desirably, these recesses 30 are defined by walls 32, the upper edges of which are coplanar with the surface of the bottom wall 10. By this arrangement, condensate water forming on the bottom wall of the carton is drawn into the recesses 30 by capillary attraction. The recesses 30 also form a reservoir for condensate dripping down the side walls of the carton. The spacing of the side walls of the tray from the side walls of

the carton provides a channel for drainage of water received within the channel formed by the flared section of the tray side walls.

In Fig. 3 is shown a modified form of the present invention in which corner lugs 34 are provided in lieu of the lugs 19. The lugs 34, as best shown in Figs. 4 and 6, are also integrally formed with the side walls and are characterized by a sloping surface 36 against which the corners of the carton impinge and a point 38 which digs into the inflexible corners of the carton to retain the tray in operative position. In Fig. 6 is shown one of the lugs 34 in the position it assumes when a carton is installed. The engagement of the lug 34 with the corner of the carton distorts the lug 34 and the corner of the carton is slightly indented.

The above-described invention contemplates the provision of a protective tray for mounting a conventional milk carton so that any foreign material that may have become attached to the bottom of the milk carton during transit will not be dislodged by contact with a refrigerator shelf to fall upon other foods below. In addition, the present tray provides for convenient disposal of condensate which forms on the outer surfaces of a carton containing a liquid at a temperature below the ambient temperature.

It will be apparent that this invention may be embodied in devices which differ in many respects and details from the particular embodiment disclosed. All modifications which do not go beyond the scope of the invention will readily suggest themselves to those skilled in the art. It is, therefore, not intended that the invention be limited to the exact construction shown and described, but only to the inventive concept as defined in the appended claims.

I claim:

1. In combination with a semi-flexible container for milk or the like, a tray adapted snugly to engage the lower side marginal edges and bottom of a cardboard milk carton or the like comprising a bottom wall and side walls, said bottom wall having a central panel defining a plurality of recesses for capillary reception of condensate from the bottom of said container, the upper marginal edges of said side walls being flared slightly outwardly and provided with a continuous bead thereby forming a channel for receiving condensate from the side walls of the container, and lugs integrally formed with said side walls at the juncture thereof, each of said lugs having a sloping upper surface for camming the carton into locking engagement with said tray and a sharp edge for engaging the corners of the carton to maintain the tray and the carton in locked relation.

2. A tray for retaining a semi-flexible container for liquids such as milk or the like, comprising a bottom wall and side walls, said bottom wall having a central panel defining a plurality of pyramidal configurations having the apexes in a common plane for capillary reception of condensate from the bottom of a container which may be received in said tray and lugs integrally formed

at the junctures of said side walls, each of said lugs having a sloping surface for camming the carton into position, said sloping surface terminating in a sharp edge for concentrated frictional engagement with the corners of the carton securely to lock the tray in operative position on the carton.

3. A tray of plastic such as polyethylene or the like for retaining a cardboard milk carton or the like comprising a bottom wall and side walls, the upper marginal edges of said side walls being flared slightly outwardly and provided with a continuous bead thereby forming a channel for receiving condensate from the side walls of a container which may be received in said tray, said side walls being provided along their inner surfaces with relatively stiff inwardly projecting pointed lugs each of which has a downwardly and inwardly sloping upper surface starting at the bead and terminating in a sharp horizontally disposed edge spaced from said bottom wall a substantially spaced distance for locking a carton in position within said tray.

4. A tray adapted to receive the lower portion of a milk carton for supporting the same and for collecting condensate therefrom, said tray having a bottom wall providing means for receiving condensate from a carton carried thereby and having upstanding side walls extending about the periphery of said bottom wall, said side walls having along the inner surface thereof a plurality of stiff inwardly projecting lugs provided with inwardly and downwardly upper surfaces sloping from said bead for guiding a carton into said tray, and said lugs being spaced from each other along said side walls and terminating in substantially horizontally directed converging edges spaced above said bottom wall for point engagement with the lower portion of a carton supported by said tray to crimp the lower side wall portions of such carton as the same is seated therein.

5. The structure of claim 4 in which said tray is rectangular in shape, said lugs being integrally formed with said side walls at the junctures thereof.

6. The structure of claim 4 in which said tray is rectangular in shape, said lugs being formed integrally with said tray and being spaced from the corners thereof to yield outwardly under tension of the side walls between the corners.

References Cited in the file of this patent

UNITED STATES PATENTS

469,490	Steers	Feb. 23, 1892
1,957,263	Gray	May 1, 1934
2,570,954	Kasman	Oct. 9, 1951
2,600,911	Olson	June 17, 1952
2,614,727	Robinson	Oct. 21, 1952
2,623,685	Hill	Dec. 30, 1952
2,731,056	Anson	Jan. 17, 1956

FOREIGN PATENTS

347,713	Great Britain	May 1, 1931
---------	---------------	-------------