

(19) World Intellectual Property Organization  
International Bureau



(43) International Publication Date  
25 July 2002 (25.07.2002)

PCT

(10) International Publication Number  
**WO 02/057719 A3**

(51) International Patent Classification<sup>7</sup>: **G01F 1/684**

**Wandler:** 17 East Roosevelt Street, Freeport, IL 61032 (US). **BLUMHOFF, Christopher, Michael;** 1008 1st Avenue, Sterling, IL 61081 (US).

(21) International Application Number: PCT/US01/51332

(22) International Filing Date:  
20 December 2001 (20.12.2001)

(74) **Agents:** **CRISS, Roger, H.** et al.; Honeywell International Inc., 101 Columbia Avenue, P.O. Box 2245, Morristown, NJ 07960 (US).

(25) Filing Language: English

(26) Publication Language: English

(81) **Designated States (national):** AU, JP, NZ.

(30) **Priority Data:**  
09/746,282 21 December 2000 (21.12.2000) US

(84) **Designated States (regional):** European patent (AT, BE, CH, CY, DE, DK, ES, FI, FR, GB, GR, IE, IT, LU, MC, NL, PT, SE, TR).

(71) **Applicant:** **HONEYWELL INTERNATIONAL INC.** [US/US]; 101 Columbia Avenue, P.O. Box 2245, Morristown, NJ 07960 (US).

**Published:**  
— with international search report

(72) **Inventors:** **GEHMAN, Richard, William;** 818 Cheshire Ct. #2, Freeport, IL 61032 (US). **SPELDRICH, Jamie,**

(88) **Date of publication of the international search report:**  
27 March 2003

[Continued on next page]

(54) **Title:** MICROELECTRONIC FLOW SENSOR

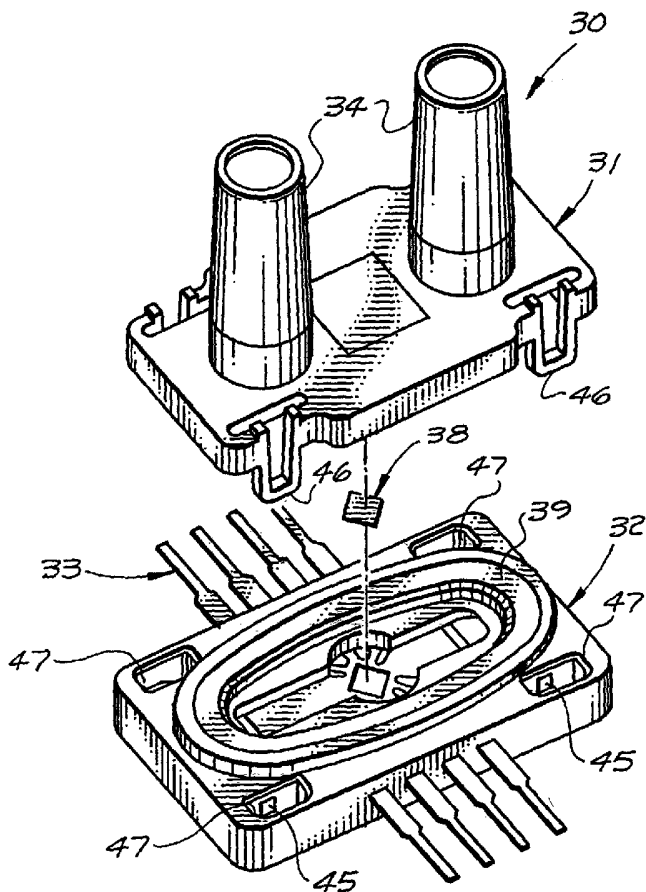

(57) **Abstract:** A system (3) for sensing or measuring the motion of a fluid (43) such as air. The system (30) typically has a two-part (31) plastic body containing an internal flow passage (41). The parts (31, 32) of the body may snap together with an adhesive. A transducer or an electronic sensor (38) is typically located within the flow passage (41), which may measure mass flow rate and may have two resistive thermal devices (RTDs) (54, 55) located on either side of a heat source (52). The body may have two elongated port tubes (34) configured to attach to tubing. The port tubes (34) may contain venturis (64), and may be substantially straight and substantially parallel, forming a U shape. A metal lead frame (33) may be provided in electrical communication with the sensor (38). The lead frame (33) may be integrally molded within the body, and may have a lower coefficient of thermal expansion than the body. The internal flow passage (41) and the sensor (38) may be substantially symmetrical and measure the flow rate of the fluid (43) substantially equally in either flow direction. The system (30) may be configured for surface mounting or for through-hole mounting, and may be a dual in-line type.



WO 02/057719 A3



---

*For two-letter codes and other abbreviations, refer to the "Guidance Notes on Codes and Abbreviations" appearing at the beginning of each regular issue of the PCT Gazette.*

INTERNATIONAL SEARCH REPORT

International Application No  
PCT/US 01/51332

<p><b>A. CLASSIFICATION OF SUBJECT MATTER</b> IPC 7 G01F1/684</p> <p>According to International Patent Classification (IPC) or to both national classification and IPC</p>											
<p><b>B. FIELDS SEARCHED</b></p> <p>Minimum documentation searched (classification system followed by classification symbols) IPC 7 G01F</p> <p>Documentation searched other than minimum documentation to the extent that such documents are included in the fields searched</p> <p>Electronic data base consulted during the international search (name of data base and, where practical, search terms used)</p>											
<p><b>C. DOCUMENTS CONSIDERED TO BE RELEVANT</b></p> <table border="1"> <thead> <tr> <th>Category °</th> <th>Citation of document, with indication, where appropriate, of the relevant passages</th> <th>Relevant to claim No.</th> </tr> </thead> <tbody> <tr> <td>X</td> <td> <p>US 4 677 850 A (MIURA KAZUHIKO ET AL) 7 July 1987 (1987-07-07)</p> <p>column 3, line 9 -column 4, line 16; figures 3-5 column 7, line 57 -column 8, line 16; figure 14</p> </td> <td> <p>1-14, 17, 20-28, 32-34, 37, 39, 40</p> </td> </tr> <tr> <td>X</td> <td> <p>US 4 829 818 A (BOHRER PHILIP J) 16 May 1989 (1989-05-16)</p> <p>the whole document</p> </td> <td> <p>1-14, 17-28, 32-34, 37, 39, 40</p> </td> </tr> </tbody> </table>			Category °	Citation of document, with indication, where appropriate, of the relevant passages	Relevant to claim No.	X	<p>US 4 677 850 A (MIURA KAZUHIKO ET AL) 7 July 1987 (1987-07-07)</p> <p>column 3, line 9 -column 4, line 16; figures 3-5 column 7, line 57 -column 8, line 16; figure 14</p>	<p>1-14, 17, 20-28, 32-34, 37, 39, 40</p>	X	<p>US 4 829 818 A (BOHRER PHILIP J) 16 May 1989 (1989-05-16)</p> <p>the whole document</p>	<p>1-14, 17-28, 32-34, 37, 39, 40</p>
Category °	Citation of document, with indication, where appropriate, of the relevant passages	Relevant to claim No.									
X	<p>US 4 677 850 A (MIURA KAZUHIKO ET AL) 7 July 1987 (1987-07-07)</p> <p>column 3, line 9 -column 4, line 16; figures 3-5 column 7, line 57 -column 8, line 16; figure 14</p>	<p>1-14, 17, 20-28, 32-34, 37, 39, 40</p>									
X	<p>US 4 829 818 A (BOHRER PHILIP J) 16 May 1989 (1989-05-16)</p> <p>the whole document</p>	<p>1-14, 17-28, 32-34, 37, 39, 40</p>									
<p><input checked="" type="checkbox"/> Further documents are listed in the continuation of box C.      <input checked="" type="checkbox"/> Patent family members are listed in annex.</p>											
<p>° Special categories of cited documents :</p> <p>*A* document defining the general state of the art which is not considered to be of particular relevance</p> <p>*E* earlier document but published on or after the international filing date</p> <p>*L* document which may throw doubts on priority claim(s) or which is cited to establish the publication date of another citation or other special reason (as specified)</p> <p>*O* document referring to an oral disclosure, use, exhibition or other means</p> <p>*P* document published prior to the international filing date but later than the priority date claimed</p> <p>*T* later document published after the international filing date or priority date and not in conflict with the application but cited to understand the principle or theory underlying the invention</p> <p>*X* document of particular relevance; the claimed invention cannot be considered novel or cannot be considered to involve an inventive step when the document is taken alone</p> <p>*Y* document of particular relevance; the claimed invention cannot be considered to involve an inventive step when the document is combined with one or more other such documents, such combination being obvious to a person skilled in the art.</p> <p>* &amp; * document member of the same patent family</p>											
<p>Date of the actual completion of the international search</p> <p>28 October 2002</p>		<p>Date of mailing of the international search report</p> <p>07/11/2002</p>									
<p>Name and mailing address of the ISA</p> <p>European Patent Office, P.B. 5818 Patentlaan 2 NL - 2280 HV Rijswijk Tel. (+31-70) 340-2040, Tx. 31 651 epo nl, Fax: (+31-70) 340-3016</p>		<p>Authorized officer</p> <p>Boerrigter, H</p>									

## INTERNATIONAL SEARCH REPORT

International Application No  
PCT/US 01/51332

## C.(Continuation) DOCUMENTS CONSIDERED TO BE RELEVANT

Category °	Citation of document, with indication, where appropriate, of the relevant passages	Relevant to claim No.
A	US 3 825 876 A (DAMON N ET AL) 23 July 1974 (1974-07-23)  the whole document -----	1-3, 7-14, 26-28, 37, 39
A	US 4 697 203 A (MATSUDA SADAMU ET AL) 29 September 1987 (1987-09-29)  the whole document -----	1, 7-14, 26-28, 37, 39

## INTERNATIONAL SEARCH REPORT

International Application No

PCT/US 01/51332

Patent document cited in search report		Publication date		Patent family member(s)	Publication date
US 4677850	A	07-07-1987	JP	59147221 A	23-08-1984
			JP	59206715 A	22-11-1984
			JP	60001524 A	07-01-1985
			JP	1664680 C	19-05-1992
			JP	3030090 B	26-04-1991
			JP	60004814 A	11-01-1985
US 4829818	A	16-05-1989	EP	0147831 A2	10-07-1985
			JP	60220864 A	05-11-1985
US 3825876	A	23-07-1974	DE	2239424 A1	22-02-1973
			FR	2148649 A1	23-03-1973
			JP	48027681 A	12-04-1973
US 4697203	A	29-09-1987	JP	60257546 A	19-12-1985
			US	4769344 A	06-09-1988