



US010763734B2

(12) **United States Patent**
Zhang et al.

(10) **Patent No.:** **US 10,763,734 B2**
(45) **Date of Patent:** **Sep. 1, 2020**

(54) **VOICE COIL MOTOR**

(71) Applicants: **TRIPLE WIN TECHNOLOGY (SHENZHEN) CO.LTD.**, Shenzhen (CN); **HON HAI PRECISION INDUSTRY CO., LTD.**, New Taipei (TW)

(72) Inventors: **Long-Fei Zhang**, Guangdong (CN); **Shin-Wen Chen**, New Taipei (TW); **Yu-Shuai Li**, Shenzhen (CN); **Kun Li**, Guangdong (CN)

(73) Assignee: **TRIPLE WIN TECHNOLOGY (SHENZHEN) CO. LTD.**, Shenzhen (CN)

(*) Notice: Subject to any disclaimer, the term of this patent is extended or adjusted under 35 U.S.C. 154(b) by 134 days.

(21) Appl. No.: **16/122,980**

(22) Filed: **Sep. 6, 2018**

(65) **Prior Publication Data**
US 2020/0052569 A1 Feb. 13, 2020

(30) **Foreign Application Priority Data**
Aug. 7, 2018 (CN) 2018 1 0892810

(51) **Int. Cl.**
H02K 41/03 (2006.01)
H02K 41/035 (2006.01)
G03B 13/34 (2006.01)
G02B 7/04 (2006.01)
H02K 11/02 (2016.01)

(52) **U.S. Cl.**
CPC **H02K 41/0356** (2013.01); **G02B 7/04** (2013.01); **G03B 13/34** (2013.01); **H02K 11/02** (2013.01)

(58) **Field of Classification Search**
CPC H02K 41/0356; H02K 11/02; G02B 7/04; G03B 13/34; G03B 13/36; Y10T 29/49005; Y10T 29/49009; Y10T 29/49012
USPC 310/12.16
See application file for complete search history.

(56) **References Cited**
U.S. PATENT DOCUMENTS
7,715,131 B2* 5/2010 Chou G02B 7/102 359/819
10,574,870 B2* 2/2020 Zhang G02B 7/026
2012/0008220 A1* 1/2012 Lee H02K 5/04 359/822
2013/0242181 A1* 9/2013 Phoon G02B 7/04 348/374
2013/0242420 A1* 9/2013 Chou H02K 41/0356 359/824
2014/0355142 A1* 12/2014 Hung G02B 7/08 359/824

(Continued)

FOREIGN PATENT DOCUMENTS
CN 207283347 U 4/2018
TW M548802 U 9/2017

Primary Examiner — Thanh Lam
(74) *Attorney, Agent, or Firm* — ScienBiziP, P.C.

(57) **ABSTRACT**
A voice coil motor includes a base, a housing, a lower-resilient member, a lens frame, a coil, a magnet, an upper-resilient member, an upper cover plate, and a pin arranged on the base. The lower-resilient member, the lens frame, the coil, the magnet, the upper-resilient member, and the upper cover plate are arranged in sequence between the base and the housing. The lens frame and the coil are integrally formed. The coil surrounds an outer surface of the lens frame.

5 Claims, 4 Drawing Sheets

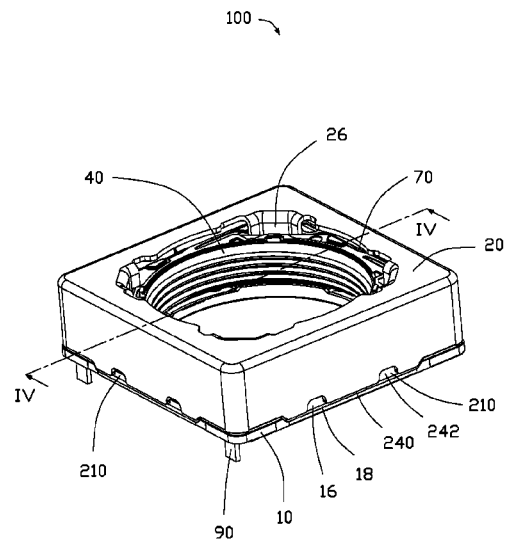

(56)

References Cited

U.S. PATENT DOCUMENTS

2015/0128407 A1* 5/2015 Shen B23K 26/20
29/605

* cited by examiner

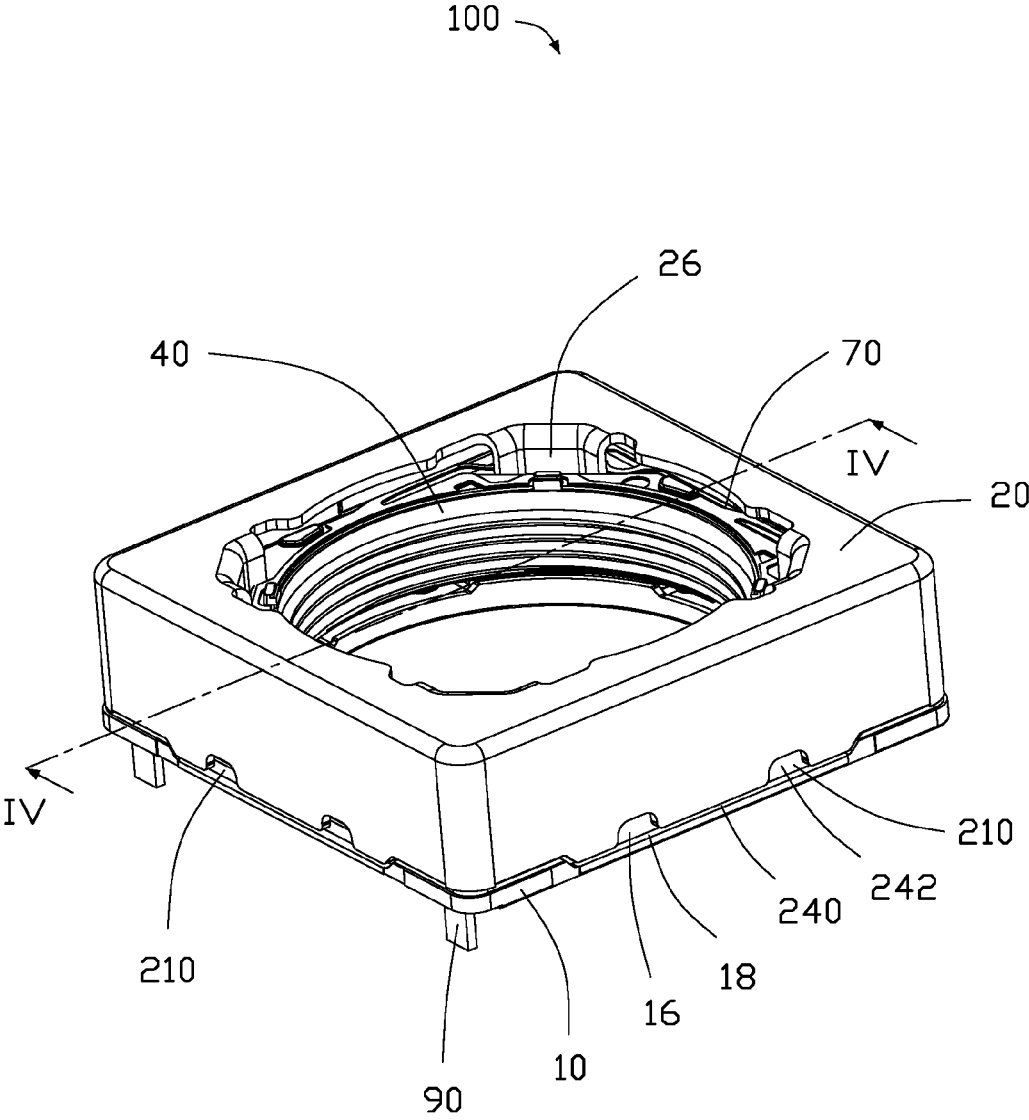

FIG. 1

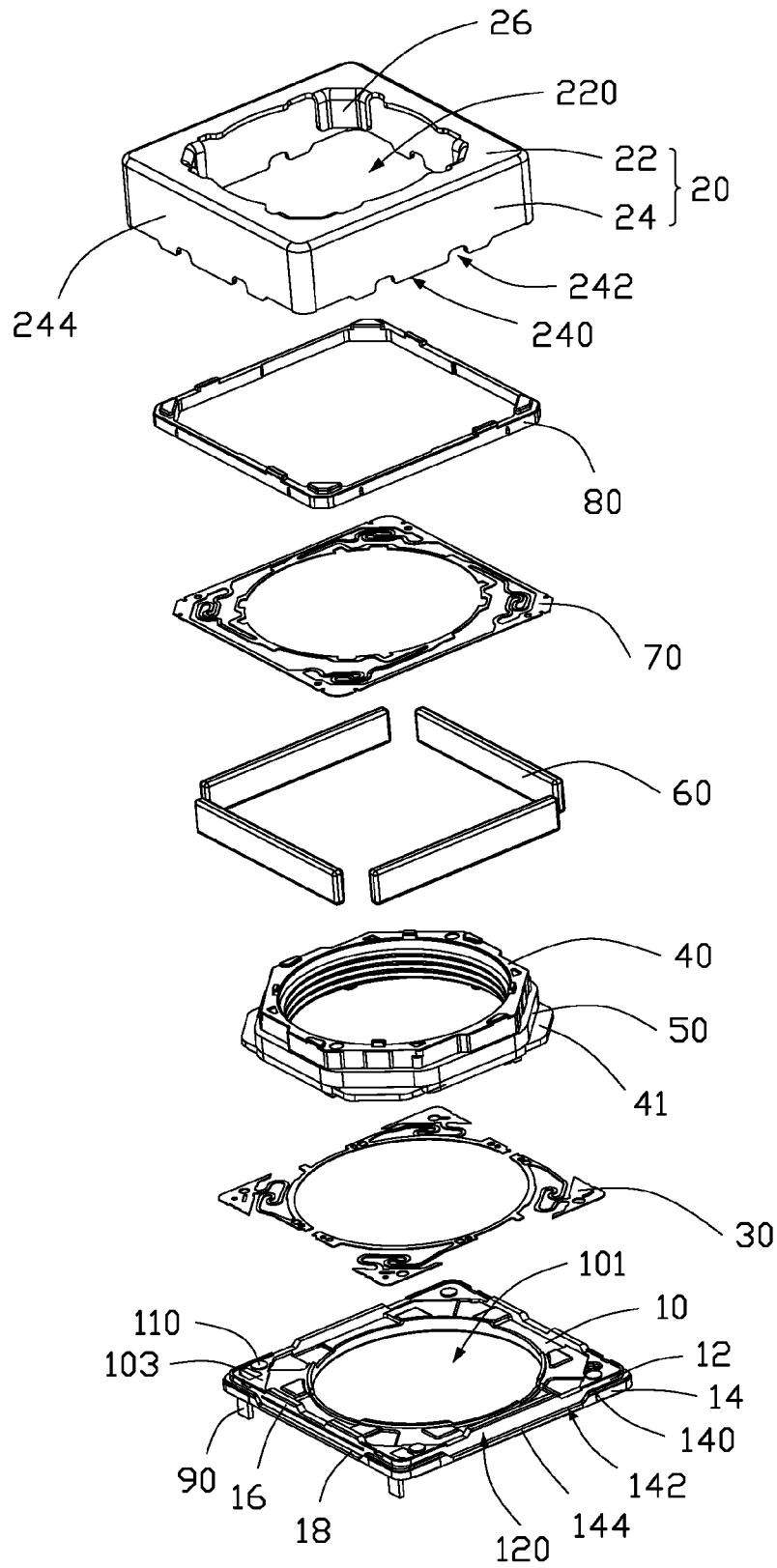

FIG. 2

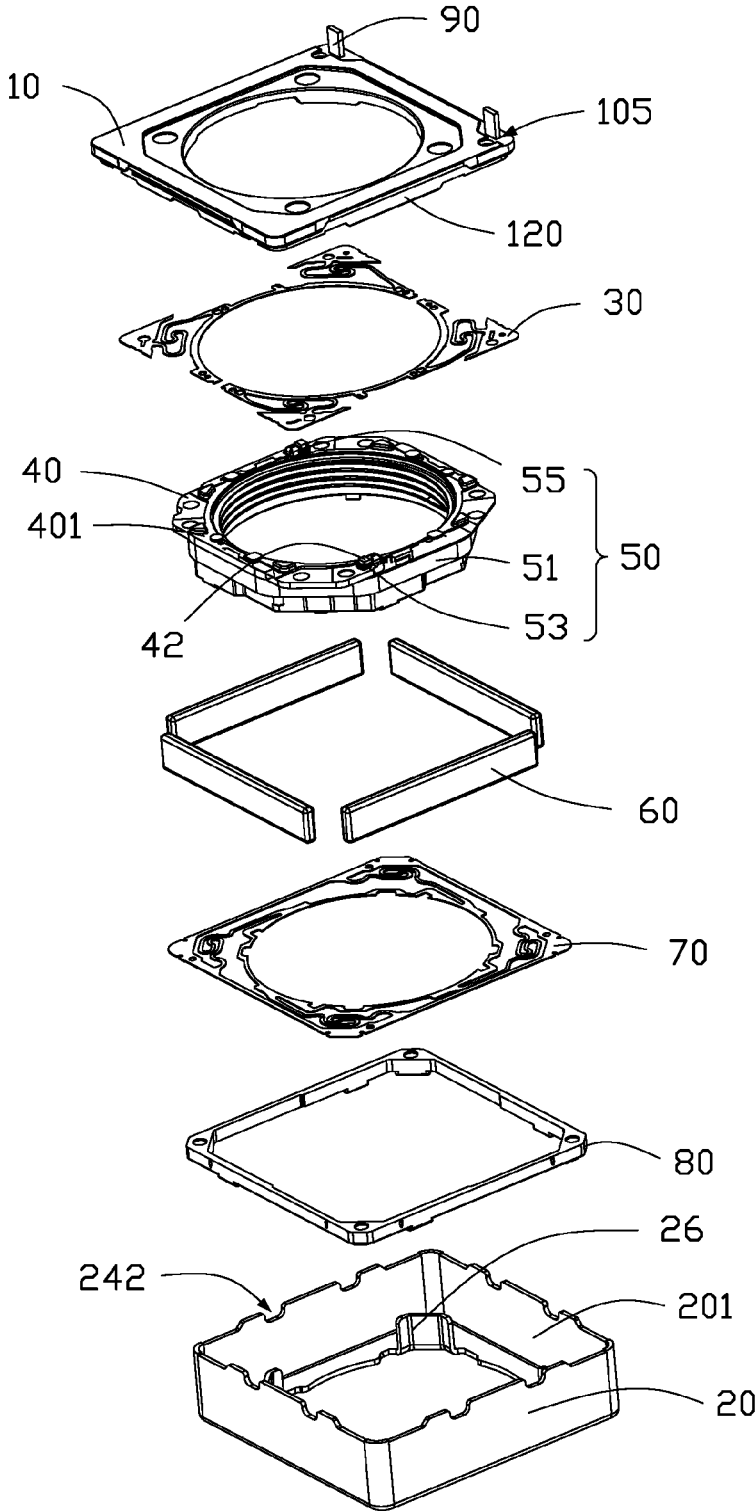

FIG. 3

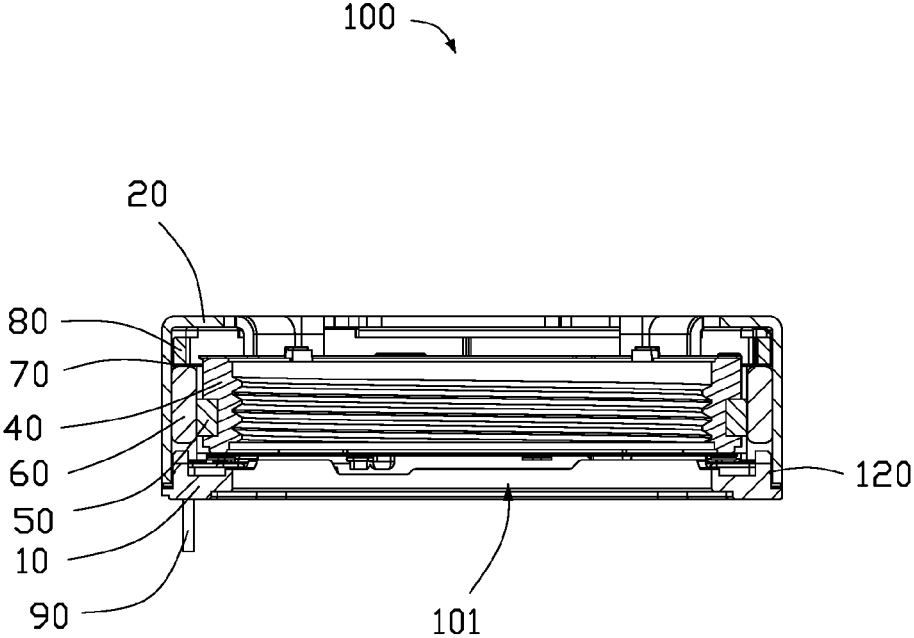

FIG. 4

1 VOICE COIL MOTOR

FIELD

The subject matter herein generally relates to voice coil motors, and more particularly to a voice coil motor having a coil integrally formed with a lens frame.

BACKGROUND

Voice coil motors are used in electronic devices, such as digital cameras and mobile phones, to drive motion within the electronic device. As electronic devices become smaller, voice coil motors need to be made smaller. However, as voice coil motors become smaller, a lens frame of the voice coil motor becomes more fragile.

Therefore, there is room for improvement within the art.

BRIEF DESCRIPTION OF THE DRAWINGS

Implementations of the present disclosure will now be described, by way of example only, with reference to the attached figures.

FIG. 1 is an assembled, isometric view of an embodiment of a voice coil motor of the present disclosure.

FIG. 2 is an exploded, isometric view of the voice coil motor in FIG. 1.

FIG. 3 is similar to FIG. 2, but showing the voice coil motor from another perspective.

FIG. 4 is a cross-sectional view of the voice coil motor in FIG. 1 taken along line IV-IV.

DETAILED DESCRIPTION

It will be appreciated that for simplicity and clarity of illustration, where appropriate, reference numerals have been repeated among the different figures to indicate corresponding or analogous elements. Additionally, numerous specific details are set forth in order to provide a thorough understanding of the embodiments described herein. However, it will be understood by those of ordinary skill in the art that the embodiments described herein can be practiced without these specific details. In other instances, methods, procedures and components have not been described in detail so as not to obscure the related relevant feature being described. The drawings are not necessarily to scale and the proportions of certain parts may be exaggerated to better show details and features. The description is not to be considered as limiting the scope of the embodiments described herein.

Several definitions that apply throughout this disclosure will now be presented.

The term “coupled” is defined as connected, whether directly or indirectly through intervening components, and is not necessarily limited to physical connections. The connection can be such that the objects are permanently connected or releasably connected. The term “substantially” is defined to be essentially conforming to the particular dimension, shape, or other word that “substantially” modifies, such that the component need not be exact. For example, “substantially cylindrical” means that the object resembles a cylinder, but can have one or more deviations from a true cylinder. The term “comprising” means “including, but not necessarily limited to”; it specifically indicates open-ended inclusion or membership in a so-described combination, group, series and the like.

2

FIGS. 1-4 show an embodiment of a voice coil motor **100**. The voice coil motor **100** includes a base **10**, a housing **20**, a lower-resilient member **30**, a lens frame **40**, a coil **50**, a magnet **60**, an upper-resilient piece **70**, an upper cover plate **80**, and pins **90**.

FIG. 2 shows the base **10** is substantially rectangular. A central portion of the base **10** defines a light hole **101**. The light hole **101** allows light to pass through to allow an image sensor (not shown) situated below the base **10** to receive the light for forming the image. The base **10** includes a sidewall **12** and an outer flange **14** coupled to an outer side of the sidewall **12**. The sidewall **12** includes four perpendicularly interconnected sidewall surfaces **120**. The outer flange **14** extends perpendicularly from the sidewall surface **120**.

The outer flange **14** of the base **10** includes an upper end surface **140** perpendicular to each sidewall surface **120**. The upper end surface **140** is concavely recessed at a central area of each sidewall surface **120**. Thus, the outer flange **14** defines a concave portion **142**. The concave portion **142** includes a step surface **144** parallel to the upper end surface **140**.

The sidewall surface **120** has a first strengthening piece **16** formed thereon. The step surface **144** has a second strengthening piece **18** formed thereon. The first and second strengthening pieces can be made of metal.

In an embodiment, the first strengthening piece **16** and the second strengthening piece **18** are integrally formed with the sidewall surface **120** and the step surface **144**, respectively, by insert molding. When the base **10** is formed by insert molding, the first strengthening piece **16** and the second strengthening piece **18** are embedded in the base **10**. The first strengthening piece **16** and the second strengthening piece **18** strengthen the base **10**.

The base **10** further includes an upper surface **103** perpendicular to each sidewall surface **120**. The upper surface **103** includes guiding projections **110** protruding therefrom. The lower-resilient piece **30** is arranged on the guiding projections **110**.

One side of the guiding projections **110** defines two through holes **105**. The two through holes **105** receive the pins **90**. The pins **90** are configured to be electrically coupled to an external circuit board.

The housing **20** is made of metal, such as iron. The housing **20** made of metal is able to reduce external electromagnetic interference of the voice coil motor **100** and prevent the voice coil motor **100** from electromagnetically interfering with the operation of external electronic components thereof. The housing **20** includes a top wall **22** and a side wall **24** perpendicularly extending from a periphery of the top wall **22**. The top wall **22** defines a light transmission hole **220**. The top wall **22** and the side wall **24** cooperatively define an accommodating space **201** to accommodate therein the lower-resilient piece **30**, the lens frame **40**, the coil **50**, the magnet **60**, the upper-resilient member **70**, and the upper cover plate **80**. A lower end **240** of the side wall **24** away from the top wall **22** defines a notch **242**.

In one embodiment, the housing **20** is substantially rectangular. The side wall **24** includes four perpendicularly interconnected sides **244**. Each side **244** defines at least one notch **242**.

In one embodiment, each side **244** defines two spaced apart notches **242**.

The housing **20** further includes a plurality of connecting pieces **26**. In at least one embodiment, a shape of each connecting piece **26** matches a shape of a corresponding corner of the housing **20**. Each connecting piece **26** extends from the top wall **22**, through the light transmission hole

220, and toward the base 10, and each connecting piece 26 is situated in a corresponding corner of the housing 20.

When the housing 20 is arranged on the base 10, the notches 242 reveal a portion of the first strengthening piece 16 and a portion of the second strengthening piece 18. The revealed portions of the first strengthening piece 16 and the second strengthening piece 18 have soldering zones 210 formed thereon. A laser or solder are used to solder the soldering zones 210 to attach the base 10 and the housing 20 together, so that the housing 20 and the base 10 do not separate from each other. After soldering the soldering zone 210, the voice coil motor 100 is turned over to face the base 10 upwards, and an adhesive is provided on the voice coil motor 100. The adhesive flows into spaces in between the base 10 and the housing 20 to further strengthen attachment of the base 10 and the housing 20.

The lower-resilient piece 30, the lens frame 40, the coil 50, the magnet 60, the upper-resilient piece 70, and the upper cover plate 80 are all received within the accommodating space 201.

The lower-resilient piece 30 is fixed onto the guiding projections 110 of the base 10.

FIG. 2 shows the lens frame 40 includes an annular step 41 surrounding an outer surface of the lens frame 40. FIG. 3 shows a bottom surface 401 of the lens frame 40 includes two fixing columns 42.

The coil 50 is formed around the outer surface of the lens frame 40. The coil 50 includes a coil body 51 and a first winding portion 53 and a second winding portion 55 coupled to the coil body 51. The first winding portion 53 and the second winding portion 55 are respectively sleeved on a corresponding one of the fixing columns 42 to fix the coil 50 to the lens frame 40.

FIG. 4 shows the coil 50 is integrally formed onto an outer surface of the lens frame 40 by insert molding embedding the coil 50 in the frame.

Integrally forming the lens frame 40 with the coil 50 helps to stabilize a torsion force of the lens frame 40 to reduce risk of deformation of the lens frame 40. Additionally, integrally forming the coil 50 with the lens frame 40 helps to prevent a head end and tail end of the coil 50 from exposing and fraying copper wire of the coil 50. Furthermore, integrally forming the lens frame 40 with the coil 50 reduces a thickness of the lens frame 40, and a size of the voice coil motor 100 is reduced.

The magnet 60 includes a plurality of individual magnets arranged around the coil 50. In one embodiment there are 4 magnets 60, one magnet for each side of coil 50. The upper cover plate 80 is substantially rectangular. The upper-resilient piece 70 is fixed between the upper cover plate 80 and an upper surface of the lens frame 40.

The coil 50 conducts a current to generate magnetic induction with the magnets 60 to cause the coil 50 to move relative to the magnets 60. The lens frame 40 and the coil 50 serve as a moving part. The magnets 60 drive the lens module to move up and down to optically focus the lens module.

When the voice coil motor 100 is in use, the lens module is installed within the lens frame 40. The voice coil motor 100 is installed on a circuit board having an image sensor so that the light transmission hole 220 faces the image sensor. The voice coil motor 100 is used to drive the lens module to move up and down to adjust focus.

A method of making the voice coil motor 100 includes the following steps.

At step S1, coil 50 is provided.

At step S2, the coil 50 is placed within an injection mold of the lens frame 40, and the lens frame 40 is formed in the injection mold. Therefore, the coil 50 is directly fixed on an outer surface of the lens frame 40.

At step S3, four first strengthening pieces 16 and four second strengthening pieces 18 are placed within an injection mold of the base 10. The base 10 is formed in the injection mold, and the first strengthening piece 16 and the second strengthening piece 18 are integrally formed on the sidewall surface 120 and the step surface 144, respectively, of the base 10.

At step S4, two pins 90 are placed within the base 10.

At step S5, the base 10, the lower-resilient member 30, the lens frame 40, the magnets 60, the upper-resilient member 70, and the upper cover plate 80 are stacked on top of each other in sequence between the housing 20 and the base 10.

At step S6, a laser or solder is used on the soldering zone 210 of the base 10 and the housing 20 to solder the base 10 and the housing 20, thereby preventing the housing 20 from separating from the base 10.

In detail, when the housing 20 is attached to the base 10, a portion of the first strengthening piece 16 and a portion of the second strengthening piece 18 are revealed. The revealed portions of the first strengthening piece 16 and the second strengthening piece 18 have formed thereon the soldering zone 210. A laser or solder are used on the soldering zones 210 to solder the soldering zones 210 to fix the base 10 and the housing 20 together.

At step S7, after the soldering zones 210 are soldered, adhesive is applied between the base 10 and the housing 20. The adhesive flows into spaces between the base 10 and the housing 20 to fix the base 10 and the housing 20. Thus, the base 10 and the housing 20 coupled together are strengthened.

The voice coil motor 100 as described above uses the lens frame 40 integrally formed with the coil 50. The lens frame 40 integrally formed with the coil 50 helps to stabilize a torsion force of the lens frame 40 to reduce risk of deformation of the lens frame 40. In addition, the coil 50 integrally formed with the lens frame 40 helps to prevent a head end and tail end of the coil 50 from exposing and fraying copper wire of the coil 50. Furthermore, the lens frame 40 integrally formed with the coil 50 reduces a thickness of the lens frame 40, and a size of the voice coil motor 100 is reduced.

The embodiments shown and described above are only examples. Even though numerous characteristics and advantages of the present technology have been set forth in the foregoing description, together with details of the structure and function of the present disclosure, the disclosure is illustrative only, and changes may be made in the detail, including in matters of shape, size and arrangement of the parts within the principles of the present disclosure up to, and including, the full extent established by the broad general meaning of the terms used in the claims.

What is claimed is:

1. A method of making a voice coil motor, the method comprising:

providing a coil;

placing the coil within an injection mold of a lens frame and forming the lens frame in the injection mold;

placing four first strengthening pieces and four second strengthening pieces within an injection mold of a base and forming the base in the injection mold;

placing two pins within the base; and

stacking on top of each other in sequence the base, a lower-resilient member, the lens frame, a magnet, an

upper-resilient member, and an upper cover plate, and then attaching a housing onto the base.

2. The method of claim 1, wherein when the coil is placed within the injection mold of the lens frame, the coil is placed on a sidewall of the injection mold, and the coil is directly fixed to an outer surface of the lens frame after the injection mold is finished molding the lens frame. 5

3. The method of claim 1, wherein after the housing is attached to the base, the base and the housing are further spot-soldered. 10

4. The method of claim 3, wherein after the base and the housing are spot-soldered, the base and the housing further have an adhesive applied thereon.

5. The method of claim 3, wherein during a process of spot-soldering the base and the housing, when the housing is buckled to the base, a portion of the first strengthening piece and a portion of the second strengthening piece are revealed between the housing and the base, and a laser or solder is used to solder the first strengthening piece and a portion of the second strengthening piece to the housing. 15 20

* * * * *