



- (51) International Patent Classification:
E21B 43/10 (2006.01) E21B 43/26 (2006.01)
E21B 43/08 (2006.01)
- (21) International Application Number:
PCT/CA2017/050650
- (22) International Filing Date:
29 May 2017 (29.05.2017)
- (25) Filing Language: English
- (26) Publication Language: English
- (30) Priority Data:
2,966,123 05 May 2017 (05.05.2017) CA
- (71) Applicant: SC ASSET CORPORATION [CA/CA]; 634
Sierra Morena Court SW, Calgary, Alberta T3H 3C3 (CA).
- (72) Inventors: CAMPBELL, Sean P.; 1826 Baywater Street
SW, Airdrie, Alberta T4B 0A8 (CA). ROJAS, Daniel;
20902 E. Cameron Ridge Dr., Cypress, Texas 77433 (US).
- (74) Agent: HORNE, D. Doak et al.; c/o Gowling WLG (Canada) LLP, TD Canada Trust Tower, Suite 1600, 421 - 7 Avenue SW, Calgary, Alberta T2P 4K9 (CA).
- (81) Designated States (unless otherwise indicated, for every kind of national protection available): AE, AG, AL, AM, AO, AT, AU, AZ, BA, BB, BG, BH, BN, BR, BW, BY, BZ, CA, CH, CL, CN, CO, CR, CU, CZ, DE, DJ, DK, DM, DO, DZ, EC, EE, EG, ES, FI, GB, GD, GE, GH, GM, GT, HN, HR, HU, ID, IL, IN, IR, IS, JP, KE, KG, KH, KN, KP, KR, KW, KZ, LA, LC, LK, LR, LS, LU, LY, MA, MD, ME, MG, MK, MN, MW, MX, MY, MZ, NA, NG, NI, NO, NZ, OM, PA, PE, PG, PH, PL, PT, QA, RO, RS, RU, RW, SA, SC,

(54) Title: SYSTEM AND RELATED METHODS FOR FRACKING AND COMPLETING A WELL WHICH FLOWABLY INSTALLS SAND SCREENS FOR SAND CONTROL

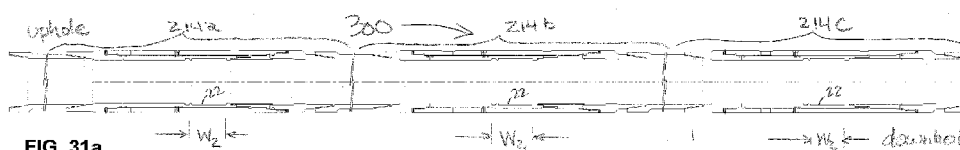

FIG. 31a

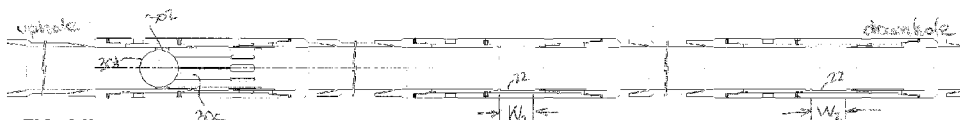

FIG. 31b

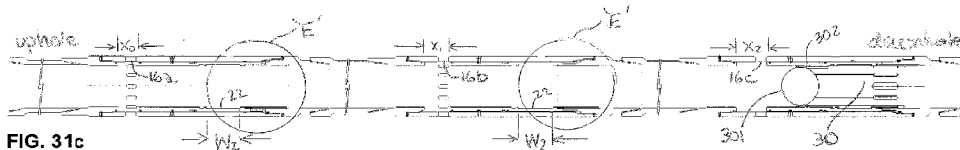

FIG. 31c

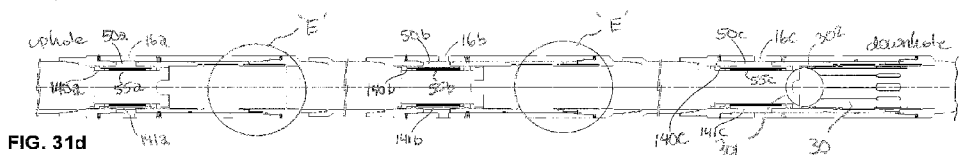

FIG. 31d

(57) Abstract: A system and method for successively fracking a wellbore at spaced intervals along tubing having frac/production ports therein. The system and method provides for flowable installation downhole of sand screen subs immediately after fracking, which become installed at each frac/production port along the tubing. Each sand screen is permeable to oil but prevents ingress of sand into the tubing via the frac ports, thereby increasing the life of a downhole pump and its components. The system and method advantageously provide a frac string which is not hindered by screens during the initial fracking operation, but which need not be "tripped out" from the well for replacement with a conventional production string having sand screens installed thereon. Instead, sand screen subs are flowed in position in the already-installed tubing string immediately after fracking, for use in sand control during production, resulting in



SD, SE, SG, SK, SL, SM, ST, SV, SY, TH, TJ, TM, TN, TR,
TT, TZ, UA, UG, US, UZ, VC, VN, ZA, ZM, ZW.

(84) Designated States (*unless otherwise indicated, for every kind of regional protection available*): ARIPO (BW, GH, GM, KE, LR, LS, MW, MZ, NA, RW, SD, SL, ST, SZ, TZ, UG, ZM, ZW), Eurasian (AM, AZ, BY, KG, KZ, RU, TJ, TM), European (AL, AT, BE, BG, CH, CY, CZ, DE, DK, EE, ES, FI, FR, GB, GR, HR, HU, IE, IS, IT, LT, LU, LV, MC, MK, MT, NL, NO, PL, PT, RO, RS, SE, SI, SK, SM, TR), OAPI (BF, BJ, CF, CG, CI, CM, GA, GN, GQ, GW, KM, ML, MR, NE, SN, TD, TG).

Published:

- with international search report (Art. 21(3))
- with amended claims (Art. 19(1))

***SYSTEM AND RELATED METHODS FOR FRACKING AND COMPLETING A WELL
WHICH FLOWABLY INSTALLS SAND SCREENS FOR SAND CONTROL***

5 **CROSS REFERENCE**

This application claims the benefit of priority from Canadian Patent Application No. 2,966,123 filed May 5, 2017 entitled: SYSTEM AND RELATED METHODS FOR FRACKING AND COMPLETING A WELL WHICH FLOWABLY INSTALLS SAND SCREENS FOR SAND CONTROL

10

FIELD OF THE INVENTION

The present invention relates to methods for completing a well within a hydrocarbon formation in order to ready the well for hydrocarbon production, and more particularly relates to methods for fracking a wellbore within a hydrocarbon formation which additionally provides for a sand screen to be flowably installed within the wellbore after the frac string has been inserted in the wellbore, for sand control, without having to trip out the frac string and insert a production string with sand screens. A system for doing the foregoing is further taught and claimed.

15

BACKGROUND OF THE INVENTION AND DESCRIPTION OF THE PRIOR ART

20

After an oil or gas well is drilled within an underground hydrocarbon formation, the zones of interest need to be completed prior to production commencing. Part of the completion process typically includes a fracking operation which involves injection of high pressure fluids into the reservoir to initiate fractures within the surrounding rock to increase porosity of “tight” formations and thereby increase the ability of hydrocarbons within the formation to flow into the wellbore and thereafter be pumped to surface.

25

Fracking operations for completing a well within a reservoir may increase production from the well by many multiples in a given time period, in some cases up to 3x or greater if conducted over the entire length of a horizontal wellbore than what would otherwise have been the case if a fracking operation had not been completed.

Accordingly, the fracking process can be a very important and critical step in preparing a wellbore for production. It is important, however, to be able to frack and complete a wellbore and ready it for production as quickly and efficiently as possible since delay further increases the expense of providing equipment such as tanker trucks for transporting frac fluid to site and remaining “on site” while frac fluid is drawn from such trucks and injected downhole, as such frac trucks typically charge at an hourly rate, to say nothing of the revenue lost arising from the delay in the well coming “on line”.

In the stimulation/fracking of directional and horizontal wells, it can be desirable to treat multiple stages in a single zone, known as a cluster, with a single fracture stimulation. It can also be desirable to treat more than one zone with a single fracture stimulation to save time and expense associated with multiple treatments and time spent running tubing and tools in and out of the wellbore.

Various prior art downhole tools and systems exist and have been used to stimulate wells by permitting treatment /fracturing in multiple contiguous regions within a single zone.

Many of such tools and systems require complex valving components within a wellbore to selectively/successively open certain ports for fracking, and thereafter open and frac at all ports along the wellbore. As a result, to the extent such systems or remnants thereof remain in the wellbore when production commences, such disadvantageously restrict flow of hydrocarbons through and thus production of hydrocarbons from, the wellbore.

Also disadvantageously, such prior art systems, to the extent that remnants of the valving remain in the wellbore when production commences, such accordingly reduce the diameter of a downhole pump which may be inserted in the wellbore when the well goes “on line” and thus require the use of smaller diameter pumps which thereby undesirably limit the rate at which hydrocarbons, typically oil, can be produced from the well.

As well, due to complex configuration and multiplicity of mechanisms to open frac ports, numerous flow restrictions exist within tubing and thus numerous pressure drops are caused occur along the length of the tubing, which result in less efficient fracking as there is greater pressure loss incurred prior to the fracture fluid contacting the zone. Ideally, less

pressure drop is desired to conduct a fracture stimulation more efficiently in each stage, to avoid having to use oversize frac injection pumps.

To avoid the aforesaid problems, resort is often had to milling out of some or all of the frac port opening/closing components prior to being able to commence production flow from the hydrocarbon bearing zones. These processes are not only expensive, but time consuming
5 as well.

It is thus desirable to have fewer or no materials/components to mill out within the bore liner, in order to be able to immediately after fracking be able to commence production from the hydrocarbon bearing zones.

10 Numerous patents and pending patent applications exist related to apparatus and systems for opening a plurality of ports in a liner within a wellbore at multiple contiguous locations therealong, to thereby permit injection of a fluid from such liner into a hydrocarbon formation, for the purpose of fracturing the formation and conditioning the formation at such locations.

15 For example, US Patent No. 8,215,411 teaches a plurality of opening sleeve/cluster valves along a liner for wellbore treatment, and utilizes a ball member or plug to open a sleeve at each valve thereby allowing fluid communication between the bore and a port in the sleeve's housing. This invention requires, however, a ball seat corresponding to each sleeve in a cluster valve, potentially restricting flow. The presence of a ball seat at each valve to be
20 opened, due to the resulting bore restriction at each valve sleeve, creates a significant pressure drop across the cluster valve assembly.

US Patent No. 8,395,879 teaches a hydrostatically powered sliding sleeve. Again, such configuration utilizes a single ball, but each sliding sleeve configuration requires its own ball seat, and the balls need to later be pumped out.

25 US Patent No. 4,893,678 discloses a multiple-set downhole tool and method that utilizes a single ball. Again, each valve requires a seat which is integral with a sliding sleeve, and which remains with each valve/port. When the sleeve/seat is forced by the ball to slide

and thereby open the port, collet fingers may then move radially outwardly, disengaging the ball and allowing the ball to further travel downhole to actuate (open) further ports.

US Patent Application Publication No. 2014/0102709 discloses a tool and method for fracturing a wellbore that uses a single ball, each valve with a deformable ball seat. Again,
5 each valve has a valve seat which remains with each valve/port.

Other patents and published applications avoid the problem of each valve/port having a ball seat which remains with each valve, and provide a dart or ball member which actuates a number of valves/ports. However, such designs are not without their own unique drawbacks.

For example, US 2013/0068484 published March 21, 2013, *inter alia* in Fig. 6 thereof,
10 (and likewise to same effect US 2004/0118564 published June 24, 2004, likewise in Fig. 6 thereof) teaches an axially movable sliding sleeve 322 which is capable of actuating (i.e. opening) a number of downhole port sleeves 325a, 325b to thereby open corresponding respective downhole ports 317a, 317a' which are normally covered by port sleeve 325a, and similarly subsequently open respective downhole ports 317b, 317b' normally covered by port
15 sleeve 325b. Sliding sleeve 322 is mounted by a shear pin 350 in the tubing string. Plug/ball 324 is inserted in the tubing, and uphole fluid pressure applied thereto cause plug 324 to travel downwardly in the in the string and abut sliding sleeve 322, further causing shear pin 350 to shear and thus sleeve 322 to then be driven downhole. Spring-biased dogs 351 on outer periphery of sliding sleeve 322 then engage inner profile 353a on sliding sleeve
20 325a and cause sleeve 325a (due to fluid pressure acting on plug 324) to move downhole thereby opening ports 317a, 317a'. As noted in paragraph [0071] therein, continued application of fluid pressure causes dogs 351 to collapse, thereby releasing sleeve 322 from engagement with inner profile 353a on sliding sleeve 325, and allowing sleeve 322 to further travel downhole and actuate (i.e. open) further sleeves in like manner. Although not expressly
25 mentioned nor shown in US 2013/0068484, seals are necessary around dogs 351 in order to allow creation of a pressure differential when such continued application of fluid pressure is applied, in order to cause collapse of such dogs to allow disengagement with a first sleeve and allow the dart to thereafter further travel downhole for subsequent actuation of additional downhole sleeves and ports. The necessity for seals around dogs 351 necessarily introduces

added mechanical complexity and the possibility of inability to release sleeve 322 from engagement if such seals were to leak due to the then-inability to create a pressure differential.

5 WO 2013/048810 entitled “Multizone Treatment System” published April 4, 2013 teaches a system and method for successively opening flow control devices (which may be sliding sleeves) in a tubing string along a length thereof, commencing with a most downhole valve and opening a sleeve at such location, and by insertion of additional darts progressing successively upwardly in the tubing string to open further uphole sleeves. The tubing string is provided with a plurality of spaced apart flow control devices, such as sliding sleeves, each
10 having an annular-located recess therein with a unique profile relative to other flow control devices. A first dart, having an engagement feature sized to correspond with a selected annular-located recess of a particular most-downhole flow control device, is injected, and such dart passes to actuate the flow control device to allow it to open a port. The process is progressively repeated for additional uphole flow control devices by injecting additional darts,
15 having corresponding features to engage a selected flow control device. The darts are then drilled out to allow production from the tubing. Disadvantageously, only one dart can open one port, and thus a plurality of contiguously spaced ports are not capable of being opened by a single dart using such apparatus/method, thereby rendering such system/method time consuming.

20 CA 2,842,568 entitled “Apparatus and Method for Perforating a Wellbore Casing, and Method and Apparatus for Fracturing a Formation” published May 29, 2014 teaches *inter alia* dart members similar to the dart of WO 2013/048810, each dart having a protruding spring-biased profile uniquely sized to engage a similarly-sized annular recess on a plurality of downhole sliding sleeves, and thereby open sliding sleeve, with further means being provided
25 on each of such sliding sleeves to allow the single dart member to further travel downhole and open additional sleeves having similar-sized annular recesses. No collet sleeve is provided, and a non-beveled surface on the annular recess of the most downhole sleeve is used to retain the dart from travelling further downhole. Disadvantageously, in comparison to the system as hereinafter described, the configuration of the dart, namely having a spring-biased profile and
30 a cup seal thereon, essentially requires the dart to be virtually solid and thereby permanent

obstruction to the wellbore once opening the last of a series of slidable sleeves. If additional uphole sleeves are desired to be actuated using a second dart (having a narrower protruding spring-biased profile than the first dart used), the first dart must be installed using a locator tool and thereafter retrieved, after actuating a plurality of sleeves and associated ports using
5 such tool, as shown in Figs. 9A-9D. Such a system involves extensive equipment from surface, and the need of a bypass port that need by opened and closed to allow effective operation. These steps and features complicate the operation of such prior art system and add to expense and time.

US Pub. 2016-0097257 (CA 2,867, 207) filed Oct. 2, 2014 entitled “*Multi-Stage Liner with Cluster Valves and Method of Use*”, commonly assigned with the present application,
10 teaches a method and system of flowing a ball and ball seat member downhole, which successively engages and disengages a plurality (cluster) of sliding sleeve members, to thereby successively open frac ports. The sliding sleeve members are initially respectively covering a plurality of longitudinally-spaced frac ports along a tubular liner in a wellbore.
15 The ball and seat member is flowed downhole by application of fluid pressure on an uphole side thereof. The ball and seat member initially engages a sliding sleeve member covering a most uphole frac port, and causes the sliding sleeve member to slide so as to uncover the associated frac port, whereupon the ball and seat member upon continued application of uphole fluid pressure becomes disengaged, and thereafter moves downhole to successively
20 engage and uncover frac ports in a cluster of sliding sleeve members.

US Pub. 2016-0097257 (CA 2,879,044) filed Jan. 22, 2015 entitled “*System and Method for Injecting Fluid at Selected Locations along a Wellbore*”, likewise commonly assigned with the present application, teaches a system and method for selectively actuating sliding sleeves to uncover associated frac ports in a tubular member, using one or more
25 actuating dart members. The dart member may thereafter be coupled to a retrieval tool and when so coupled allows a bypass valve to be opened and disengagement of the dart member from the associated sleeve to allow withdrawing the dart member uphole and from within the tubular member. Specifically, upward movement of the retrieval tool allows a wedge-shaped member on the dart member to disengage the dart member from a corresponding actuated
30 sliding sleeve, to thereby allow the dart member to be withdrawn from the wellbore.

US Pub. 2016-0312580 (CA 2,904,470) filed Apr. 27, 2015 entitled “*System for Successively Uncovering Ports along a Wellbore to permit Injection of a Fluid along said Wellbore*” having a common inventor and likewise commonly assigned with the present application, teaches a system for moving sleeves to successively uncover a plurality of
5 contiguous ports in a tubing liner within a wellbore which are covered by such sleeves, or for successively uncovering individual groups of ports arranged at different locations along the liner, to allow successive fracking of the wellbore at such locations. Sliding sleeves in the tubing liner are successively moved from a closed position covering a respective port to an
10 open position uncovering such port by an actuation member placed in the bore of the tubing liner and pumped down the tubing liner. The actuation member for moving the sliding sleeves to cause them to open comprises a single collet sleeve, having a dissolvable plug retained in a fixed position within such collet sleeve by shear pins. The collet sleeve has radially-outwardly
15 biased protuberances (fingers) at a downhole end thereof, adapted to and which matingly engage corresponding cylindrical grooves in such sliding sleeves, based on the width of the protuberance. Upon the actuation member actuating all of the desired sleeves and after
20 having actuated the last most downhole sleeve, the shear pin shears thereby allowing the plug in the collet to move downhole in the collet sleeve and thereby prevent the protuberances (fingers) on the collet sleeve from thereafter disengaging the cylindrical groove of the corresponding sliding sleeve, thereby preventing any further progress of the collet sleeve
downhole.

US Ser. No. 14/991,597 (CA 2,916,982) filed Jan. 8, 2017 entitled “*Collet Baffle System and Method for Fracking a Hydrocarbon Formation*”, likewise commonly assigned with the present application, teaches a baffle system for progressively fracking or treating a
25 formation via a plurality of longitudinally spaced frac ports along a tubular liner. The baffle members each have a collet finger protuberance thereon of a unique width relative to other baffle members. Each collet finger protuberance on an uphole edge thereof has a chamfer which allows disengagement of the collet finger protuberance and thus removal of the baffle member from the wellbore when the baffle member is pulled uphole by a wireline retrieval
tool.

30 None of the aforesaid patents/publications, however, teach or in any way suggest how

such systems or methods could be further adapted to provide not only fracking, but further provide sand control during production without having to trip out the frac string from the wellbore.

5 Fracking fluid is usually an incompressible liquid for the purpose of fracturing the rock, and may contain various adjuvants such as acids and/or diluents to increase followability of the oil/gas from the formation.

10 In addition, fracking fluids commonly contain proppants such as fine sand (frac sand) or ceramic beads of consistent and engineered uniform diameter, to uniformly “prop” open the created fractures and maintain such fractures in the formation so that hydrocarbons may better flow from the formation.

15 As explained below, the introduction of large quantities of frac sand into a formation during the fracking process typically results in significant quantities of frac sand being entrained in the oil or gas which flows back into the wellbore for pumping to surface. Due to the abrasive nature of sand, such results in additional increased and heavy wear on pump components within the well, greatly shortening pump life. Downhole pumps, and even downhole pumps most resistive to sand abrasion such as progressive cavity pumps, are typically expensive, and frequent replacement thereof results in increased costs not only in replacing/refurbishing the pump and its components, but further results in service rig time and costs in having to “trip out” of a well a downhole pump and “run back in” the production string with a new pump, to say nothing of the lost production and profits due to the well being “off line” during the time of such repairs.

20 Sand screens are known in the art, and are typically inserted within a production string, after the tripping out of the frac string from the well. The production string is then separately “run in” wellbore.

25 Disadvantageously, however, the aforesaid two-step process having to frac, trip out the frac string, and then run in a production string with pre-installed sand screens thereon results in considerable additional time and expense in tripping out the frac string, and thereafter running in the production string with elongate cylindrical screens installed thereon.

There is also an inherent risk of damaging the screens during “run in” of the production string in the wellbore.

5 A more efficient system which allows not only fracking, but further immediately thereafter allows production and sand control during such production, without having to trip out a frac string, would be very beneficial to the wellbore completion industry.

10 The above-background information and description of prior publications is provided for the purpose of making known information believed by the applicant to be of possible relevance to the present invention. No admission is necessarily intended nor should be construed, that any of the below publications and information provided below constitutes prior art against the present invention.

SUMMARY OF THE INVENTION

15 It is an object of the invention that sand from a hydrocarbon formation, and additional sand resulting from conducting a fracking operation along a wellbore within the formation, be prevented to a greater degree from entering a wellbore during production operations and otherwise detrimentally affecting pumping equipment, to say nothing of increased disposal requirements in respect of such sand.

It is a further object of the invention that a frac string not have to be “tripped out” and a separate production string, with sand screens installed thereon at surface, be thereafter “run in” to the well, in order to commence production from the well after fracking operations.

20 It is a further object of the invention that fracking be able to be completed without the impediment of, or potential damage to, sand screens, and without having to “trip out” the frac string and “run in” a production string, with sand screens installed thereon at surface.

25 It is a further object of the invention to provide a system and method which reduces instances of damage being inflicted to sand screens when they are positioned within a wellbore downhole.

It is a still further object to be able to immediately after fracking, and prior to the frac

string having to be “tripped out” of the well, provide frac screens at the locations of the frac ports and fractures in the well, to immediately thereafter prevent, as much as possible, the ingress of sand into the wellbore and the deleterious results which occur therefrom.

Reference herein and below to “uphole” and “downhole” with regard to a particular component of the system, or with respect to the method of the present invention, is a reference to a location on the component within a wellbore where uphole means in the direction of the surface along a wellbore, and “downhole” is the correspondingly opposite direction towards a toe of the wellbore.

Reference herein and below and herein to an element in the singular, such as by use of the article "a" or "an" is not intended to mean "one and only one" unless specifically so stated, but rather "one or more". In addition, where reference to “fluid” is made, such term is considered meaning all liquids and gases having fluid properties.

Accordingly, in order to meet some or all of the above objects, in a first broad embodiment the present invention comprises a system for fracking a hydrocarbon formation at a given location along a wellbore and installing a sand screen after fracking at said location, for sand control during subsequent production from the fracked formation, comprising;

- a tubular liner insertable within said wellbore and having an interior bore, further comprising:

(a) a plurality of spaced-apart frac ports longitudinally spaced at intervals along said tubular liner, providing, when open, fluid communication between the interior bore of the tubular liner and an exterior of the tubular liner;

(b) a corresponding plurality of cylindrical hollow sliding sleeve members, each configured in an initial closed position to cover a corresponding of said frac ports and prevent flow of fluid from the interior bore to an exterior of the tubular liner, and slidably moveable longitudinally in the interior bore to an open position to uncover said corresponding of the frac ports, each sliding sleeve member initially covering a respective of said plurality of frac ports so

as to prevent flow of a fluid from within the interior bore to the exterior of the tubular liner, each of the sliding sleeve members having an interior circumferential groove profile therein of a given longitudinal width; and

(c) a plurality of shear members, initially securing respectively said slidable sleeve members to the tubular liner in the initial closed position thereof, and sheareable when a longitudinal force is applied thereto to thereafter allow longitudinal slidable movement of respective of said slidable sleeve members;

- at least one actuation member, insertable within the interior bore of the tubular liner, comprising:

(a) a cylindrical hollow collet sleeve, having a radially-outwardly biased protuberance on a periphery thereof having a first profile, said radially-outwardly biased protuberance configured to matingly engage said interior circumferential groove profile on at least one of the plurality of sliding sleeve members;

(b) a burst plate, dissolvable plug member, or a seating surface configured to provide a sealing surface against which a dissolvable plug member may abut, which burst plate, plug member, or sealing surface in combination with said plug member, at least for a limited time prevents pressurized fluid injected downhole in said interior bore from travelling past said actuation member in said tubular liner thereby allowing said actuation member to be flowed downhole by said pressurized fluid;

- at least one cylindrical sand screen sub, insertable within the interior bore of said tubular liner and displaceable within said tubular liner to a location therein proximate a one of said frac ports in said tubular liner whose corresponding sliding sleeve member has been uncovered by said actuation member, said at least one sand screen sub comprising:

(a) a cylindrical hollow member having at an uphole end thereof a dissolvable plug member or burst plate which at least for a limited time substantially obstructs passage of fluid within said interior bore thereby causing

pressurized fluid injected downhole in said bore of said tubular liner to force said sand screen sub downhole in said tubular liner;

5 (b) a cylindrical, longitudinally-extending oil-permeable screen mesh forming a portion of an outer periphery of said sand screen sub downhole from said dissolvable plug member or burst plate thereon, which screen mesh when said sand screen sub is located proximate said one of said frac ports, underlies said one of said frac ports and prevents ingress of sand but permits ingress of oil, from said formation into the interior bore via said one of said frac ports; and

10 (c) a resiliently outwardly biased retaining member, which engages, directly or indirectly, said tubular liner when said sand screen sub has flowed down said tubular liner to said one of said frac ports whose corresponding sliding sleeve member has been opened and to a position within the tubular liner wherein the screen mesh of said sand screen sub underlies said one of said frac ports, which retaining member after engagement with said tubular liner
15 prevents uphole displacement of said sand screen sub in said tubular liner.

Advantageously, as may be now understood by a person of skill in the art, the tubing liner and associated sliding sleeve members which are uncovered after the fracking operation need not be tripped out of the wellbore and a production tubing liner, having sand
20 screens installed thereon at surface, thereafter run into the wellbore in order to commence production.

Instead, and advantageously, the opened frac port in the above system may immediately, after fracking and insertion of the sand screen subs into the tubing liner, then be used to allow flow of oil from the fracked formation into the tubing liner, substantially
25 screened of sand. Such oil, screened of sand and substantially sand-free, may then be pumped to surface, and such pumping equipment thereby enjoying greater life due to the reduced quantities of abrasive sand in the oil being pumped to surface.

In a first refinement, to ensure that the sand screen sub may flow downhole in the tubular liner to the desired position beneath a desired (typically lowermost) opened frac port, the resiliently outwardly biased retaining member on said at least one sand screen sub has a chamfer on a downhole side edge thereof and a flat face on an uphole side edge thereof
5 perpendicularly disposed to a longitudinal axis of said tubular liner. Downhole movement of said at least one sand screen sub in said tubular liner is allowed by fluid pressure being exerted on an uphole side of said sand screen sub forcing said chamfer on said downhole edge against a portion of the tubing liner, thereby causing said resiliently outwardly biased retaining member to become radially depressed and thereby allowing continued downhole
10 movement. In contrast, uphole movement of said sand screen sub is prevented by said flat face engaging, indirectly or indirectly, an annular region in said tubular liner.

To ensure each of the sliding sleeves, which have uncovered a corresponding frac/production port, remain open during production, in a preferred embodiment each of the sliding sleeve members, and the tubular liner at a location proximate each of said frac ports,
15 have mating engagement means which become respectively lockingly engaged when said sliding sleeve members are each respectively moved to said open position, to thereby retain said sliding sleeve members, once in said open position, from thereafter returning to a closed position. In preferred embodiments the mating engagement means on said sliding sleeve members comprises a plurality of collet fingers, radially outwardly biased, and extending from
20 a downhole end of each sliding sleeve member, and said mating engagement means on said tubular liner comprises an annular circumferential ring on said tubular member, which when said slidable sleeve member travels to said open position, said collet fingers thereof matingly engage said annular circumferential ring on said sliding sleeve member.

25 In a preferred embodiment, the mating engagement means on the sliding sleeve members may take the form of a radially-outwardly biased collet finger(protuberance) having a profile of width W_2 , and the mating engagement means on the sliding sleeve member take the form of an interior circumferential groove of a width or profile corresponding to that of the radially outwardly biased protuberance, to allow mating engagement thereof so as to allow
30 the sliding sleeve members to be moved by the one or more actuation members to the open

position. Other mating engagement means, such as a resiliently-biased lock ring, are well known and will now be apparent to a person of skill in the art.

5 In an alternative or additional further refinement, the profile of the radially outwardly biased protuberance on the actuation member may similarly comprise a raised collet profile of a width W_2 , and the interior circumferential groove profile of given longitudinal width on one of said sliding sleeve members comprises a mating circumferential groove of a width equal to or greater than W_2 .

10 In a further embodiment of the system of the present invention, a plurality of actuation members [i.e. at least a second (additional) actuation member) may be used, wherein each actuation member possesses a radially-outwardly biased protuberance having a unique profile, which is adapted to matingly engage a similarly unique profile/interior circumferential groove or grooves) on a desired one of the sliding sleeve members, so that
15 each actuation member engages only one sliding sleeve member, and causes when engaged with the particular unique sliding sleeve member such sleeve member to uncover an associated frac/production port.

Accordingly, in one embodiment of such further refinement, each one or all of the aforesaid systems may further comprise:

20 a second actuation member, insertable within the interior bore of the tubular liner, comprising:

25 **(a)** a cylindrical hollow collet sleeve, having a radially-outwardly biased protuberance on a periphery thereof having a second profile of width W_1 , where $W_1 < W_2$, said radially-outwardly biased protuberance configured to matingly engage said interior circumferential groove profile on another of the plurality of sliding sleeve members, having a width equal to or greater than W_1 but less than W_2 ;

(b) a burst plate, dissolvable plug member, or a seating surface situated at an

uphole end of said collet sleeve configured to provide a sealing surface against which a dissolvable plug member may abut, which burst plate, plug member, or plug member and sealing surface are situated at an uphole end of said collet sleeve and at least for a limited time prevent pressurized fluid injected downhole in said interior bore from travelling past said actuation member in said tubular liner;

- a second sand screen sub, insertable within the interior bore of said tubular liner comprising:

(a) a cylindrical hollow member having at an uphole end thereof a dissolvable plug member or burst plate which at least for a limited time substantially obstructs passage of fluid within said interior bore thereby causing pressurized fluid injected downhole in said bore of said tubular liner to force said sand screen sub downhole in said tubular liner ;

(b) a cylindrical, longitudinally-extending oil-permeable screen mesh forming a portion of an outer periphery of said second sand screen sub downhole from said dissolvable plug member or burst plate thereon, which screen mesh when said sand screen sub is located proximate said one of said frac ports, underlies said one of said frac ports and prevents ingress of sand but permits ingress of oil, from said formation into the interior bore via said one of said frac ports; and

(c) a retaining member on said cylindrical hollow member, which engages, directly or indirectly, said tubular liner when said second sand screen sub has flowed down said tubular liner to another of said frac ports whose corresponding sliding sleeve member has been opened on said tubular liner by said second actuation member to a position wherein the screen mesh of said sand screen sub underlies said another of said frac ports, which retaining member after engagement with said tubular liner prevents uphole displacement of said second sand screen sub in said tubular liner.

In one embodiment, the radially-outwardly biased protuberance on the actuation member is configured such that after matingly engaging said interior circumferential groove profile on at least one of the plurality of sliding sleeve members, such radially-outwardly biased protuberance on said actuation member remains lockingly engaged with said interior circumferential groove profile on said slidable sleeve and said actuation member is thereby prevented from further downhole movement within said tubular liner.

In such above embodiment, after said actuation member has moved a most downhole of said sliding sleeves to an open position uncovering said corresponding frac port, and said sand screen sub flowed downhole to underlie the uncovered frac port, further movement of said at least one sand screen sub downhole in said tubing liner is prevented by said sand screen sub abutting said actuation member.

Alternatively, rather than using a plurality of uniquely-configured actuation members to each engage uniquely configured individual sliding sleeve members and thereafter frac the reservoir at the particularly location of the opened port, it may be desired to frac a particular zone within a formation wherein such zone extends along a region of the wellbore having a plurality (cluster) of frac/production ports. In may be thus desired to have a single actuation member instead successively engage and cause a plurality of sliding sleeve members to uncover a corresponding plurality of associated frac/production ports, frac at such opened frac ports, and thereafter install sand screen subs at each opened frac port, before then inserting a differently configured additional actuation member to open an (or plurality of) additional frac port(s).

Accordingly, in such configuration the system employs a single actuation member, which is capable of engaging a first sleeve and causing the first sleeve to open its associated frac port, disengage the sliding sleeve member and further move downhole to similarly engage additional sliding sleeves and open additional frac ports.

Accordingly, in a further refinement, to provide for a system of such a configuration, in a first broad embodiment of such a system further comprises providing the radially-outwardly biased protuberance on the collet sleeve of the actuation member with a chamfer

on a downhole side thereof. Upon the radially-outwardly biased protuberance engaging the interior circumferential groove profile in the at least one sliding sleeve member and the at least one sliding sleeve member being moved downhole to open said desired frac port and further fluid pressure applied uphole to said actuation member, the chamfer engages a
5 downhole side edge of the circumferential groove within the respective sliding sleeve and the radially-outwardly biased protuberance thereafter becomes disengaged from mating engagement in the circumferential groove thereby allowing said actuation member to disengage from the respective sliding sleeve (now in an open position) and continue moving downhole to successively engage one or more additional sliding sleeve members and open
10 corresponding additional frac ports.

In such further refinement, the at last one sand screen sub comprises a plurality of sand screen subs, and when inserting sand screen subs, it will be necessary that each sand screen sub, on the retaining member thereof, possess a “keying” feature, so that each sand screen sub will only become installed at a particular successive downhole location. Otherwise,
15 in absence of such “keying” feature, when flowing a first sand screen sub downhole after uncovering the ports and after having completed the fracking operation for the cluster of opened frac ports, such first sand screen sub would lockingly engage the tubing liner at the most uphole location of an opened port, and further successive sand screen subs would not be able to be flowed downhole to provide sand control for other (more downhole) uncovered frac
20 ports.

Accordingly, in a further refinement of the aforesaid further refinement, the at least one sand screen sub comprises a plurality of sand screen subs, and:

the retaining member on each sand screen sub possesses a unique profile; and

the tubular liner, proximate each frac port, possesses an annular region of a
25 corresponding unique profile or width;

wherein the retaining member of each sand screen sub, when said one of said sand screen subs is flowed down the tubular liner, will only engage the tubular liner at a particular annular region along the tubing liner, and the retaining member thereof after engagement with

said interior circumferential groove or grooves, thereafter prevents further displacement of said sand screen sub from said position in said tubular liner.

In a refinement, the retaining member on each sand screen sub is of a unique width
5 relative to a width of a retaining member on another of said sand screen subs; and

wherein a retaining member of width "X₂" on a first sand screen sub inserted downhole is of a greater width than a width X₁ of a retaining member on a second sand screen sub thereafter subsequently inserted downhole in said tubular liner; and

said retaining member on said first sand screen sub matingly engages a corresponding
10 annular region in said tubular liner of an equal or greater width X₂; and

said retaining member on said second sand screen sub matingly engages a corresponding annular region of width $\geq X_1$ but $< X_2$, located uphole in said tubular liner.

In one embodiment of the above systems, the actuation member may further of a material or composition such that it is dissolvable, upon a corrosive fluid being flowed into
15 and applied to the interior bore of the tubular liner.

In a further broad aspect of the invention, the invention comprises a method for conducting a fracking procedure at least one location along a wellbore situated within a hydrocarbon formation, and thereafter installing a sand screen within a tubular liner within said wellbore to prevent ingress of sand into said tubular liner.

20 In such aspect of the invention, the invention comprises a method comprising the steps of:

- (i) locating a tubular liner having:
- a hollow interior bore;
 - a plurality of frac ports spaced along a periphery of said tubular
25 liner;
 - a corresponding plurality of sliding sleeve members respectively initially covering each of said frac ports;

within said wellbore;

5 (ii) situating a first actuation member having a resiliently outwardly biased protuberance of a first profile, within said tubular liner ;

10 (iii) applying a pressurized fluid to an uphole end of said first actuation member and causing said first actuation member to flow downhole and to a position in said tubular liner where said radially outwardly-biased protuberance thereon engages a mating profile on one of said plurality of sliding sleeve members;

15 (iv) continuing to apply said pressurized fluid to said tubular liner and causing said one sliding sleeve member and actuation member to together move downhole and uncover and thereby open an associated of said frac ports in said tubular liner and thereby allow fluid communication from said interior bore to an exterior of said tubular liner and said hydrocarbon formation via the opened associated frac port;

20 (v) injecting a fracking fluid into said tubular liner and causing said frac fluid to flow into the hydrocarbon formation via the opened frac port;

(vi) inserting a first sand screen sub into said tubular liner, said first sand screen sub having:

- a resiliently-outwardly biased protuberance having a given profile; and

25 - an annular screen mesh about an outer periphery of said first sand screen sub; and

(vii) applying a pressurized fluid to an uphole end of said first sand screen

sub and causing said first sand screen sub to flow downhole to a position in said tubular liner where said annular screen mesh thereof underlies said open frac port and causing said profile of said resiliently-outwardly biased protuberance thereon to engage a mating profile on an interior of said tubular liner and thereby retain said first sand screen sub in a position wherein the annular screen mesh thereof underlies said open frac port.

In a further refinement of the above method, such method may further comprise the step, after step **(iv)** or step **(v)**, of injecting pressurized fluid into said interior bore at a pressure sufficient to rupture a burst disk member located on said actuation member, so as to thereafter allow fluid to flow through said actuation member.

In a further or alternative refinement of the above method comprising steps (i)-(vii), such method may further comprise the step after step **(vii)** of injecting pressurized fluid into said interior bore at a pressure sufficient to rupture a burst disk member located on said sand screen member, so as to thereafter allow fluid to flow through said sand screen member.

In a further or alternative refinement of the above method comprising steps (i)-(vii), such method may further comprise the step, at some time after step **(iv)**, of dissolving a plug member in said actuation member to allow subsequent flow of fluid through said actuation member after said actuation member has moved said sliding sleeve downhole and thereby opened said associated frac port. The step of dissolving said plug member further comprises flowing a corrosive fluid down said tubular liner to said actuation member.

In a further or alternative refinement of the above method comprising steps (i)-(vii), such method may further comprise the step after step **(vii)** of exposing said sand screen sub to a corrosive fluid so as to dissolve a portion of said sand screen sub so as to thereafter allow fluid to flow longitudinally through said sand screen sub.

In a further or alternative refinement of the above method comprising steps (i)-(vii), such method may further comprise the step at some time after step **(iv)** of flowing a corrosive fluid into said interior bore and causing said actuation member to dissolve.

In a further or alternative refinement of the above method comprising steps (i)-(vii),
5 when said first actuation member engages said one sliding sleeve member and moves said sliding sleeve member to said open position, causing said actuation member to lockingly engage said sliding sleeve member, and said sliding sleeve member to further lockingly engage said tubing liner, thereby preventing further movement of said actuation member within said tubing
10 liner.

The above method comprising steps (i)-(vii) may further, where is desired to conduct a fracking procedure at a plurality of spaced apart locations along said wellbore and installing sand screens within the tubular liner at each of said plurality of locations to prevent ingress of sand into the tubular liner at each of said locations, be modified wherein, after step **(vii)**,
15 such method further comprises carrying out the following further steps:

(viii) situating a second actuation member having a resiliently-outwardly biased protuberance of a second profile thereon different than said first profile, within said tubular liner;

(ix) applying a pressurized fluid to an uphole end of said second actuation member and causing said second actuation member to flow downhole and to a position in said tubular liner where said second profile on said second actuation member engages a corresponding mating profile on a further one of said sliding sleeve members;

(x) continuing to apply said pressurized fluid to said tubular liner and causing said second actuation member and said further one of sliding sleeve member to together move downhole and uncover and thereby open a further associated of said frac ports in said tubular liner and thereby allow fluid communication from said interior bore to an exterior
30 of said tubular liner and said hydrocarbon formation via the further opened frac port;

(xi) injecting a fracking fluid into said tubular liner and causing said frac fluid to flow into the hydrocarbon formation via the further opened frac port;

(xii) situating a second sand screen sub within said tubular liner, said second sand screen sub having a resiliently-outwardly biased protuberance thereon and an annular screen mesh about an outer periphery thereof; and

(xiii) applying a pressurized fluid to an uphole end of said second sand screen sub and causing said second sand screen sub to flow downhole to a position in said tubular liner where said screen mesh thereon underlies said further opened frac port, and causing said resiliently-outwardly biased protuberance on said second sand screen sub to engage a mating profile on an interior of said tubular liner proximate said further opened frac port so as to thereby retain said second sand screen sub and said annular screen mesh thereof underlying said further opened frac port .

Preferably in such modified method the resiliently-outwardly biased protuberance of said first actuation member is of a width W_2 , and said resiliently-outwardly biased protuberance of said second actuation member is of a width W_1 , wherein $W_1 < W_2$.

In an alternative method of the present invention, a method is provided for fracking a hydrocarbon formation at a plurality of clustered contiguous locations along a wellbore within said formation using only one actuation member rather than several. Such method is used where it is desired to frac a plurality of group of contiguous locations along a wellbore. Such alternative method comprises the steps of:

(i) locating a tubular liner having:

-a hollow interior bore;

- a plurality of contiguous frac ports spaced along a periphery of said tubular liner;

- a corresponding plurality of sliding sleeve members respectively initially covering each of said frac ports;

tubular liner and said hydrocarbon formation via the further opened second frac port;

(vii) injecting a fracking fluid into said tubular liner and causing said frac fluid to flow into the hydrocarbon formation via the opened first and second frac ports;

(viii) situating a first sand screen sub within said tubular liner, said first sand screen sub having a resiliently-outwardly biased protuberance having a profile, and said first sand screen sub further having an annular screen mesh about an outer periphery thereof;

(ix) applying a pressurized fluid to an uphole end of said first sand screen sub and causing said first sand screen sub to flow downhole to a position in said tubular liner where said annular screen mesh thereof underlies said second open frac port and causing said profile of said protuberance thereon to engage a mating profile on an interior of said tubular liner and thereby retain said first sand screen sub and said annular screen mesh thereof underlying said second open frac port;

(x) situating a second sand screen sub within said tubular liner, said second sand screen sub having a resiliently-outwardly biased protuberance having a profile different than the profile of the protuberance on said first sand screen sub, and likewise having an annular screen mesh about an outer periphery thereof;

(xi) applying a pressurized fluid to an uphole end of said second sand screen sub and causing said second sand screen sub to flow downhole to a position in said tubular liner where said annular screen mesh thereof underlies said first open frac port, and causing said profile of said protuberance thereon to engage a mating profile on an interior of said tubular liner and thereby retain said second sand screen sub and said annular screen mesh thereof underlying said first open frac port.

The above method comprising steps (i)-(xi) may further comprise the step after step (iv), (vi) or (vii) of injecting pressurized fluid into said interior bore at a pressure sufficient to rupture a burst disk member located on said actuation member so as to thereafter allow fluid to flow through said actuation member.

The above method comprising steps (i)-(xi) with or without the above further modification may further comprise the step after step (vii) of injecting pressurized fluid into said interior bore at a pressure sufficient to rupture a burst disk member located on said sand screen member, so as to thereafter allow fluid to flow through said sand screen member .

The above method comprising steps (i)-(xi) with or without the above further modifications may further comprise the step after step (vii) of exposing said actuation member to a corrosive fluid so as to dissolve a portion of said actuation member so as to thereafter allow fluid to flow through said actuation member.

The above method comprising steps (i)-(xi) with or without the above further modifications may further comprise the step the step sometime after step (vi) of exposing said actuation member to a corrosive fluid so as to dissolve all or substantially all of said actuation member.

The above method comprising steps (i)-(xi) with or without the above further modifications may further comprise the step comprising the step after step (viii) of exposing said first sand screen sub to a corrosive fluid so as to dissolve a portion of said first sand screen sub so as to thereafter allow fluid to flow longitudinally through said first sand screen sub.

The above method comprising steps (i)-(xi) with or without the above further modifications may further comprise the step, after step (x), of exposing said second sand screen sub to a corrosive fluid so as to dissolve a portion of said second sand screen sub so as to thereafter allow fluid to flow longitudinally through said second sand screen sub.

In addition, the above method comprising steps (i)-(xi) with or without the above further modifications may further comprise the step, after step **(iv)** and step **(vi)** of allowing a biased protuberance on said sliding sleeve member to, when the first and second sliding sleeve member have respectively uncovered a respective frac port, to engage a mating groove in said tubular member so as to retain, respectively, said first and second sliding sleeve member in a position where a respective associated frac port is uncovered.

In the alternative to the method comprising steps (i) –(xi), an plurality of actuation members may be used, each having a collet finger (radially outwardly biased protuberance thereon) of a unique width or profile. Such method comprises successively uncovering spaced-apart frac ports situated along a hollow tubular liner, carrying out a fracking operation at each uncovered frac port, and installing a sand screen at each of said uncovered frac ports, and in particular comprises the steps of:

(i) locating an actuation member having a resiliently outwardly biased collet finger of a given profile thereon in said tubular liner, said tubular liner initially having a plurality of sliding sleeve members respectively covering a corresponding plurality of said spaced-apart frac ports along said tubular liner;

(ii) flowing said actuation member downhole so as to cause said profile on said first actuation member to engage an interior circumferential groove on a sliding sleeve member covering an lowermost covered frac port along said tubular liner, wherein said interior circumferential groove profile corresponds to said profile on said collet finger, and injecting fluid into said tubular liner and causing said actuation member and said lowermost sliding sleeve member to together move downhole and thereby uncover an associated of said ports in said tubular liner and causing a resiliently-biased protuberance on said lowermost sliding sleeve member to then engage an aperture in said tubular liner so as to cause said lowermost sliding sleeve member to thereafter remain immovable within said tubular liner;

(iii) injecting a pressurized frac fluid into said tubular liner to frac the formation at the location of the opened frac port;

(iv) injecting or allowing fluid in said tubular liner to dissolve a plug in said actuation member, or alternatively applying pressurized fluid in said tubular liner to burst a plug or disk in said actuation member, so as to thereafter allow longitudinal flow of fluid through said actuation member;

5 (v) injecting a sand screen sub down said tubular liner, said sand screen sub having a resiliently-outwardly biased protruding member thereon, which sand screen sub upon reaching said first actuation member then underlies said opened port and said protruding member thereafter prevents said sand screen sub from moving back uphole; and

10 (vi) repeating steps (i)-(v) until all of said plurality of spaced-apart ports along said tubular liner have been uncovered, the wellbore fracked at each opened frac port, and sand screen subs installed at each opened frac port.

BRIEF DESCRIPTION OF THE DRAWINGS

15 Further advantages and permutations and combinations of the invention will now appear from the above and from the following detailed description of the various particular embodiments of the invention, taken together with the accompanying drawings each of which are intended to be non-limiting, in which:

20 **Fig.'s 1-10** show one system and successive steps in one method of the present invention, wherein:

25 **Fig. 1** is a cross-sectional view of a tubing liner showing three successive longitudinally-spaced frac/production ports therein, each frac/production port initially slidably covered by a corresponding a slidable sleeve member, each slidable sleeve having an interior circumferential groove therein of width W_0 , W_1 , and W_2 respectively;

Fig. 2 is a subsequent view of the tubing liner of **Fig. 1**, wherein a first actuation member has been flowed downhole along the tubing liner, and a radially outwardly biased protuberance thereon has engaged a corresponding

interior circumferential groove on the sliding sleeve on the lowermost (ie. most downhole) sliding sleeve member;

Fig. 3 is a subsequent view of the tubing liner of **Fig. 2**, wherein pressurized fluid applied uphole has caused longitudinal downhole displacement of the actuation member and most downhole sliding sleeve member, so as to thereby uncover the associated frac/production port, and where fracking of the formation can be completed via the opened frac port;

Fig. 3A is a subsequent view of the tubing liner of **Fig. 3**, wherein fluid applied uphole has caused bursting and subsequent disappearance of, or corrosive dissolution of, a plug member on an uphole side of said actuation member;

Fig. 4 is a subsequent view of the tubing liner of **Fig. 3A**, wherein a first sand screen sub has been run into the tubing liner, and become positioned below the frac/production port in the liner, and the retainer member thereon engaged the tubing liner to retain the sand screen sub in place within the liner;

Fig. 4A is a subsequent view of the tubing liner of **Fig. 4** wherein fluid applied uphole has caused bursting and subsequent disappearance of, or corrosive dissolution of, a plug member on an uphole side of said first sand screen sub;

Fig. 5 is a subsequent view of the tubing liner of **Fig. 4**, wherein a second actuation member has been flowed downhole along the tubing liner, and a radially outwardly biased protuberance thereon has engaged a corresponding interior circumferential groove on the sliding sleeve on the penultimate (ie. next most downhole) sliding sleeve member;

Fig. 6 is a subsequent view of the tubing liner of **Fig. 5**, wherein pressurized fluid applied uphole has caused longitudinal downhole displacement of the second actuation member and associated sliding sleeve member, so as to thereby uncover the associated frac/production port and where fracking of the

formation can be completed at the location of the additionally-opened frac port;

Fig. 6A is a subsequent view of the tubing liner of **Fig. 6**, wherein fluid applied uphole has caused bursting and subsequent disappearance of, or corrosive dissolution of, a plug member on an uphole side of the sand screen sub;

Fig. 7 is a subsequent view of the tubing liner of **Fig. 6A**, wherein a second sand screen sub has been run into the tubing liner, and become positioned below the second frac/production port in the liner and the retainer member thereon engaged the tubing liner to retain the second sand screen sub in place within the liner;

Fig. 7A is a subsequent view of the tubing liner of **Fig. 7** wherein fluid applied uphole has caused bursting and subsequent disappearance of, or corrosive dissolution of, a plug member on an uphole side of said second sand screen sub;

Fig. 8 is a subsequent view of the tubing liner of **Fig. 7A**, wherein a third actuation member has been flowed downhole along the tubing liner, and a radially outwardly biased protuberance thereon has engaged a corresponding interior circumferential groove on the sliding sleeve on the next most uphole sliding sleeve member;

Fig. 9 is a subsequent view of the tubing liner of **Fig. 8**, wherein pressurized fluid applied uphole has caused longitudinal downhole displacement of the third actuation member and associated sliding sleeve member, so as to thereby uncover the associated frac/production port, and where fracking of the formation can be completed at the location of the additionally-opened frac port;

Fig. 9A is a subsequent view of the tubing liner of **Fig. 6**, wherein fluid

applied uphole has caused bursting and subsequent disappearance of, or corrosive dissolution of, a plug member on an uphole side of the third sand screen sub;

5 **Fig. 10** is a subsequent view of the tubing liner of **Fig. 9A**, wherein a third sand screen sub has been run into the tubing liner, and become positioned below the third frac/production port in the liner, and the retainer member thereon engaged the tubing liner to retain the third sand screen sub in place within the liner, and production has commenced with oil flowing into the tubing liner and passing through each of the sand screens at each of the
10 associated (opened) ports;

Fig. 11 is an enlarged view of **region 'A'** of **Fig. 2**, **Fig. 5**, and **Fig. 8**;

Fig. 12 is an enlarged view of **region 'B'** of **Fig. 2**;

Fig. 13 is an enlarged view of **region 'C'** of **Fig. 2**;

Fig. 14 is an enlarged view of **region 'D'** of **Fig. 4**;

15 **Fig. 15a** is an enlarged view of the first actuation member, shown for example in **Fig. 2**, having a radially outwardly biased protuberance having a profile of width '**W₂**';

Fig. 15b is a cross section through the first actuation member of **Fig. 15a**, with the burst plate on the first actuation member still intact;

20 **Fig. 15c** is an enlarged view of the second actuation member, shown for example in **Fig. 5**, having a radially outwardly biased protuberance having a profile of width '**W₁**';

Fig. 15d is a cross section through the second actuation member of **Fig. 15c**, with the burst plate on the second actuation member still intact;

Fig. 15e is an enlarged view of the third actuation member, shown for example in **Fig. 8**, having a radially outwardly biased protuberance having a profile of width '**W₀**';

Fig. 15f is a cross section through the second actuation member of **Fig. 15e**, with the burst plate on the third actuation member still intact;

Fig. 16a is a perspective view of a sand screen sub, having a resiliently outwardly biased retaining member thereon;

5 **Fig. 16b** is a cross-section of the sand screen sub shown in **Fig. 16a**, taken along plane 'S'-'S';

Fig.'s 17-24A show a further system and successive steps in a second method of the present invention, wherein:

10 **Fig. 17** is a cross-sectional view of a tubing liner showing three successive longitudinally-spaced frac/production ports therein, each frac/production port initially slidably covered by a corresponding a slidable sleeve member, each slidable sleeve having an interior circumferential groove therein of width W_0 , W_1 , and W_2 respectively;

15 **Fig. 18** is a subsequent view of the tubing liner of **Fig. 17**, wherein a first actuation member has been flowed downhole along the tubing liner, and a radially outwardly biased protuberance thereon of width W_2 has engaged a corresponding interior circumferential groove of similar width W_2 on the sliding sleeve on the lowermost (i.e. most downhole) sliding sleeve member;

20 **Fig. 19** is a subsequent view of the tubing liner of **Fig. 18**, wherein pressurized fluid applied uphole has caused longitudinal downhole displacement of the actuation member and most downhole sliding sleeve member, so as to thereby uncover the associated frac/production port and create a circumferential groove of width ' X_2 ' in the tubing liner, and where fracking of the formation can be completed via the opened frac port;

25 **Fig. 19A** is a subsequent view of the tubing liner of **Fig. 19**, wherein fluid applied uphole has caused bursting and subsequent disappearance of, or corrosive dissolution of, a plug member on an uphole side of said actuation

member;

Fig. 20 is a subsequent view of the tubing liner of **Fig. 19A**, wherein a first sand screen sub has been run into the tubing liner, and become positioned below the frac/production port in the liner, and the outwardly-biased retainer member thereon of width X_2 engaged the tubing liner to retain the first sand screen sub in place within the liner;

Fig. 20A is a subsequent view of the tubing liner of **Fig. 20** wherein fluid applied uphole has caused bursting and subsequent disappearance of, or corrosive dissolution of, a plug member on an uphole side of said first sand screen sub;

Fig. 21 is a subsequent view of the tubing liner of **Fig. 20A**, wherein pressurized fluid applied uphole has caused a second actuation member to have flowed downhole along the tubing liner, and a radially outwardly biased protuberance thereon of width W_1 engaged a corresponding interior circumferential groove of width W_1 on the sliding sleeve on the penultimate (ie. next most downhole) sliding sleeve member, and wherein the pressurized fluid has further caused longitudinal downhole displacement of the second actuation member and associated sliding sleeve member so as to thereby uncover the associated frac/production port and further create a circumferential groove of width X_1 in the tubing liner, and where fracking of the formation can be completed at the location of the additionally-opened frac port;

Fig. 21A is a subsequent view of the tubing liner of **Fig. 21**, wherein fluid applied uphole has caused bursting and subsequent disappearance of, or corrosive dissolution of, a plug member on an uphole side of the second sand screen sub;

Fig. 22 is a subsequent view of the tubing liner of **Fig. 21A**, wherein a second sand screen sub has been run into the tubing liner and become positioned below the second frac/production port in the liner, and the outwardly-biased

retainer member thereon of width ' X_1 ' engaged the circumferential groove of width ' X_1 ' in tubing liner to retain the second sand screen sub in place within the liner;

5 **Fig. 22A** is a subsequent view of the tubing liner of **Fig. 22** wherein fluid applied uphole has caused bursting and subsequent disappearance of, or corrosive dissolution of, a plug member on an uphole side of said second sand screen sub;

10 **Fig. 23** is a subsequent view of the tubing liner of **Fig. 22A**, wherein a third actuation member has been flowed downhole along the tubing liner, and a radially outwardly biased protuberance thereon of width W_0 has engaged a corresponding interior circumferential groove of similar width W_0 in the sliding sleeve on the next most uphole sliding sleeve member, and wherein the pressurized fluid has further caused longitudinal downhole displacement of the third actuation member and associated sliding sleeve member so as to

15 thereby uncover the associated frac/production port and further create a circumferential (annular) groove of width ' X_0 ' in the tubing liner, and where fracking of the formation can be completed at the location of the additionally-opened frac port;

20 **Fig. 23A** is a subsequent view of the tubing liner of **Fig. 23**, wherein fluid applied uphole has caused bursting and subsequent disappearance of, or corrosive dissolution of, a plug member on an uphole side of the third actuation member ;

25 **Fig. 24** is a subsequent view of the tubing liner of **Fig. 23A**, wherein a third sand screen sub has been run into the tubing liner, and become positioned below the third frac/production port in the liner, and the outwardly-biased retainer member thereon of width ' X_0 ' engaged the created circumferential groove of width ' X_0 ' in the tubing liner to thereby retain the third sand screen sub in place within the liner;

Fig. 24A is a subsequent view of the tubing liner of **Fig. 24**, wherein fluid applied uphole has caused bursting and subsequent disappearance of, or corrosive dissolution of, a plug member on an uphole side of the third actuation member sand screen sub, and the tubing liner is ready for production from the further opened frac/production ports;

Fig. 25a is a perspective view of the first sand screen sub in the method of **Figs. 17-24A**, having a resiliently outwardly biased retaining member thereon of width X_2 ;

Fig. 25b is a cross-sectional view of the first sand screen sub of **Fig. 25a**, taken along plane 'S'-'S' of **Fig. 25a**;

Fig. 26a is a perspective view of the second sand screen sub in the method of **Figs. 17-24A**, having a resiliently outwardly biased retaining member thereon of width X_1 ;

Fig. 26b is a cross-sectional view of the second sand screen sub of **Fig. 26a**, taken along plane 'T'-'T' of **Fig. 26a**;

Fig. 27a is a perspective view of the first sand screen sub in the method of **Figs. 17-24A**, having a resiliently outwardly biased retaining member thereon of width X_0 ;

Fig. 25b is a cross-sectional view of the first sand screen sub of **Fig. 27a**, taken along plane 'U'-'U' of **Fig. 27a**;

Fig.'s 26-30a show a further system and successive steps in a third method of the present invention, wherein:

Fig. 26 is a cross-sectional view of a tubing liner, showing three successive longitudinally-spaced frac/production ports therein, each frac/production port initially slidably covered by a corresponding a slidable sleeve member, each slidable sleeve having an interior circumferential groove therein of fixed width W_2 ;

Fig. 27 is a subsequent view of the tubing liner of **Fig. 26**, wherein a first actuation member has been flowed downhole along the tubing liner, and

engaged the three sliding members and caused them to uncover the associated frac/production port and further and create a circumferential groove of width X_0 , X_1 , and X_2 at the location of the respective frac/production ports, the tubing liner, and wherein and a radially outwardly biased protuberance thereon of width W_2 has engaged a corresponding interior circumferential groove of similar width W_2 on the sliding sleeve on the lowermost (i.e. most downhole) sliding sleeve member; and where fracking of the formation can be completed via the opened frac port;

Fig. 27a is a subsequent view of the tubing liner of **Fig. 27**, wherein fluid applied uphole has caused bursting and subsequent disappearance of, or corrosive dissolution of, a plug member on an uphole side of said first actuation member;

Fig. 27b depicts an optional additional step in the aforesaid method, wherein the first actuation member is dissolvable in a corrosive fluid, and a corrosive fluid has been streamed downhole to dissolve the first actuation member after having actuated the associated sliding sleeve member to an open position;

Fig. 28 is a subsequent view of the tubing liner of **Fig. 27A**, wherein a first sand screen sub has been run into the tubing liner, and become positioned below the frac/production port in the liner, and the outwardly-biased retainer member thereon of width X_2 engaged the tubing liner to retain the first sand screen sub in place within the liner;

Fig. 28a is a subsequent view of the tubing liner of **Fig. 28** wherein fluid applied uphole has caused bursting and subsequent disappearance of, or corrosive dissolution of, a plug member on an uphole side of said first sand screen sub;

Fig. 29 is a subsequent view of the tubing liner of **Fig. 21A**, wherein a second sand screen sub has been run into the tubing liner and become positioned below the second frac/production port in the liner, and the outwardly-biased

retainer member thereon of width ' X_1 ' engaged the circumferential groove of width ' X_1 ' in tubing liner to retain the second sand screen sub in place within the liner;

5 **Fig. 29a** is a subsequent view of the tubing liner of **Fig. 29** wherein fluid applied uphole has caused bursting and subsequent disappearance of, or corrosive dissolution of, a plug member on an uphole side of said second sand screen sub;

10 **Fig. 30** is a subsequent view of the tubing liner of **Fig. 29a**, wherein a third sand screen sub has been run into the tubing liner, and become positioned below the third frac/production port in the liner, and the outwardly-biased retainer member thereon of width ' X_0 ' engaged the created circumferential groove of width ' X_0 ' in the tubing liner to thereby retain the third sand screen sub in place within the liner;

15 **Fig. 30a** is a subsequent view of the tubing liner of **Fig. 30**, wherein fluid applied uphole has caused bursting and subsequent disappearance of, or corrosive dissolution of, a plug member on an uphole side of the third actuation member sand screen sub, and the tubing liner is ready for production from the further opened frac/production ports;

20 **Fig.'s 31a-31f** show a further alternative system and successive steps in a third method of the present invention, wherein:

25 **Fig. 31a** is a cross-sectional view of a tubing liner, showing three successive longitudinally-spaced frac/production ports therein, each frac/production port initially slidably covered by a corresponding a slidable sleeve member, each slidable sleeve having an interior circumferential groove therein of fixed width W_2 ;

Fig. 31b is a subsequent view of the tubing liner of **Fig. 31a**, wherein a first actuation member comprising a seating surface and a ball plug member, has

been flowed downhole along the tubing liner, and engaged the most uphole of the three sliding sleeve members ;

Fig. 31c is a subsequent view of the tubing liner of **Fig. 31b**, wherein the actuation member has caused each of the sliding sleeve members to uncover the associated frac/production port, and further create a circumferential groove of width X_0 , X_1 , and X_2 at the location of the respective frac/production ports, in the tubing liner, and wherein a radially outwardly biased protuberance thereon of width W_2 has engaged a corresponding interior circumferential groove of similar width W_2 on the sliding sleeve on the lowermost (i.e. most downhole) sliding sleeve member; and where fracking of the formation can be completed via the opened frac ports;

Fig. 31d is a subsequent view of the tubing liner of **Fig. 31c**, wherein first, second, and third sand screen subs have been successively run into the tubing liner, and become positioned below the frac/production port in the liner, and the outwardly-biased retainer member thereon of width X_2 , X_1 , and X_0 thereon respectively engaged the tubing liner to retain the first, second, and third sand screen subs in place within the liner;

Fig. 31e is a subsequent view of the tubing liner of **Fig. 31d**, wherein corrosive fluid applied uphole has caused corrosive dissolution of the ball plug member; and

Fig. 31f is a subsequent view of the tubing liner of **Fig. 31d**, wherein corrosive fluid applied uphole has further caused corrosive dissolution of the actuation member, where the actuation member is configured to be dissolvable in a corrosive fluid; and

Fig. 32 is an enlarged view of region "E" of **Fig. 27b**, **Fig. 28**, and **Fig. 31f**.

DETAILED DESCRIPTION OF SOME PREFERRED EMBODIMENTS

One embodiment of the present invention, namely system/method **10**, is depicted in successive steps illustrated in **Figs. 1-10**.

As regards the particular system/method **10** shown in **Figs.1-10**, the system/method **10** uses a plurality of actuation members **30a, 30b, 30c** which are successively flowed downhole, each actuation member **30a, 30b, 30c** having a corresponding radially outwardly biased protuberance **31a, 31b, 31c** thereon of a unique profile/width **W₀, W₁, and W₂**. The unique profile/width **W₀, W₁, and W₂** of each radially outwardly biased protuberance **31a, 31b, 31c** allows each actuation member to selectively engage a circumferential groove profile **22a, 22b, 22c** of equal (or greater) profile/width **W₀, W₁, and W₂** on a corresponding sliding sleeve member **18a, 18b, 18c**, to thereby engage and slidably cause to open an associated of frac ports **16a, 16b, 16c**.

After the opening of a frac port, and after a fracking operation is carried out at the respective opened frac port, one of sand screen subs **40a, 40b, 40c** is flowed downhole and comes to rest against the last-installed actuation member **30a, 30b, 30c**, as the case may be, so that the sand screen sub underlies the respective opened frac/production port **16a, 16b, 16c**.

A retaining member **41a, 41b, 41c** on the respective sand screen sub **40a, 40b, 40c** engages a respective annular region **50a, 50b, 50c** in the tubing liner **12**, so as to prevent the sand screen sub **40a, 40b, 40c** from being dislodged from its position underlying the respective opened frac port **16a, 16b, 16c**.

Accordingly, with reference to **Fig. 1-10**, commencing with **Fig. 1**, such system/method **10** initially comprises, as shown in **Fig. 1**, a tubing liner **12** having an interior bore **13** and a plurality of discrete sections **14a, 14b, 14c** coupled together in end-to-end relation to form the tubing liner **12**, which is run into a wellbore (not shown). Each discrete section **14a, 14b, 14c** has a corresponding frac port /production port **16a, 16b, 16c**.

Frac/production ports **16a, 16b, 16c** of respective tubing sections **14a, 14b, 14c** are each initially, during “run in” of the tubing liner **12** into the wellbore, covered by a respective

sliding sleeve member **18a, 18b, 18c** as shown in **Fig. 1** so as to prevent ingress of detritus such as sand into the interior bore of the tubing liner during such “run-in”. Sliding sleeve members **18a, 18b, 18c** are thus initially in an initial closed position covering frac/production ports **16a, 16b, 16c** and initially held in such closed position by shear members **20a, 20b, 20c** coupling the sleeve members to the tubing liner **12**. Shear members **20a, 20b, 20c** are respectively shearable when a longitudinal force is transmitted by an actuation member, as explained below, to the corresponding sliding sleeve member **18a, 18b, 18c** to cause the slidable sleeve members **18a, 18b, 18c** to be slidably moved downhole to an open position where a respective frac/production port **16a, 16b, 16c** is then uncovered, thereby allowing fluid communication between an exterior of tubing liner **12** and interior bore **13** thereof.

Each of sliding sleeve members **18a, 18b, 18c** possesses an interior circumferential groove profile **22a, 22b, 22c**, which in a preferred embodiment is of a given longitudinal width, namely $W_0, W_1,$ and W_2 respectively, where $W_0 < W_1 < W_2$.

Fig. 2 shows a further successive step in the system/method **10**, wherein a first actuation member **30c** [as best shown in enlarged (perspective) view in **Fig. 15a** and in enlarged cross-sectional view in **Fig. 15b**] and having a frangible burst disk or a dissolvable disk **33c** at an uphole side thereof, is flowed down tubing liner **12** and through discrete sections **14a, 14b, to 14c** by applying a pressurized fluid to an uphole side of actuation member **30c**. Due to radially outwardly biased protuberance **31c** having a unique profile/width W_2 which only matingly engages the interior circumferential groove profile **22c** of similar or greater width W_2 on most downhole section **14c**, only sliding sleeve member **18c** is engaged by actuation member **30c**. Circled area ‘A’, shown in enlarged view in **Fig. 11**, depicts shear member **20c**, prior to being sheared, securing sliding sleeve member **18c** to tubular liner segment **14c**, and shows annular groove **39** in sliding sleeve member **18c** having bevelled edge **39’** thereon to allow the radially outwardly biased protuberance **31c** of actuation member **30c** to pass over annular groove **39** and engage interior circumferential groove profile **22c** on sliding sleeve member **18c**.

As may be seen in circled area “B” in **Fig. 2** and as shown enlarged in **Fig. 12**, a downhole end of sliding sleeve member **18c** comprises a plurality of longitudinally-extending

collet fingers **43c**, radially outwardly biased, each adapted at distal ends **43'** thereof to matingly engage with at least one annular circumferential ring **44** on tubular liner **12**, when slidable sleeve member **18c** is moved to the open position uncovering frac/production ports (see **Fig. 3**, as described below). When sliding sleeve members are in the closed position, distal ends **43'** thereof may matingly engage a more uphole annular circumferential ring **45**, as shown in **Fig. 2** in circled area “**B**” and enlarged in **Fig. 12**. In such manner the shearable members **20a**, **20b**, **20c** are assisted in the temporary securement of slidable sleeve members **18a**, **18b**, **18c** to respective sections **14a**, **14b**, **14c** of tubing liner **12**.

As may be seen from the subsequent configuration of the system/method **10** depicted in **Fig. 3**, continued injection of pressurized fluid within tubing liner **12** has caused continued force to be applied to an uphole side of actuation member **30c**, namely against frangible burst disk or a dissolvable disk **33c**, causing actuation member **30c** lockingly engaged with sliding sleeve member **18c** to together slidably move downhole whereby frac/production port **16c** becomes uncovered and thus opened to fluid communication with interior bore **13** of tubing liner **12**. As may further be seen in circled area “**C**” of **Fig. 3** and as best seen enlarged in **Fig. 13**, and in comparison to area “**B**” in **Fig. 2**, the plurality of collet fingers **43c** on sliding sleeve member **18c**, at the distal end **43'** thereof, has due to downhole displacement of slidable sleeve member **18c**, matingly engaged annular circumferential ring **45** in tubular liner **12**. As best shown in **Fig. 13**, sliding sleeve member **18c** has accordingly then been lockingly fixed in position and prevented from not only further progression downhole but also from returning to a closed position covering frac port **16c**.

Fracking of the reservoir, at the particular location of the opened frac port **16c**, is carried out at this point in the method/system **10**.

Thereafter, as may be seen from the subsequent configuration of the system/method **10** depicted in **Fig. 3A**, one of either two things has occurred—either a pulse of high pressure fluid has been applied to the uphole side of a frangible disk **33c** on actuation member **30c** so as to cause disk **33c** thereof to rupture and disintegrate, or if disk **33c** is of a dissolvable type upon application of a corrosive fluid (not shown), a corrosive fluid has been flowed downhole to dissolve disk **33c**.

As may be seen from the subsequent configuration of the system/method **10** depicted in **Fig. 4**, a sand screen sub **40c** (as shown in area “**D**” of **Fig. 4** and in enlarged view in **Fig. 14**) has been flowed downhole in tubing liner **12** and come to rest against actuation member **30c** which is now lockingly engaged with tubing liner **12**.

5 Sand screen sub **40c** comprises a cylindrical hollow portion **51c**, having at an uphole end thereof a dissolvable plug member or burst plate **53c**, which at least for a limited time substantially obstructs passage of fluid within interior bore **13** and causes pressurized fluid injected downhole in tubing liner **12** to force sand screen sub **51c** downhole into a position abutting an uphole end of actuation member **30c**.

10 Importantly, sand screen sub **40c** is provided with a cylindrical, longitudinally extending oil-permeable screen mesh **55c** forming part of an outer periphery thereof. Screen mesh **55c** when sand screen sub **40c** is flowed into the above position shown in **Fig. 4**, abutting actuation member **30c**, prevents ingress of sand into interior bore **13** of tubing liner **12** but permits ingress of oil from a hydrocarbon formation (not shown) into interior bore **13**
15 of tubing liner **12** via opened frac port **16c**.

When sand screen sub **40c** is flowed into position as shown in **Fig. 4**, namely whereby screen mesh **55c** underlies opened frac port **16c**, a resiliently outwardly-biased retaining member **41c** extends radially outwardly into an annular region **50c** formed within tubing liner **12**, thereby then preventing any subsequent uphole displacement of sand screen
20 sub **40c** within tubing liner **12**.

As best seen in **Fig. 14**, retaining member **41c** is provided with a chamfer **60c** on a downhole side edge thereof and a substantially flat face **59c** on an uphole side edge thereof perpendicularly disposed to a longitudinal axis **70** of tubular liner **12**. Downhole movement of sand screen sub **40c** within tubing liner **12** is thereby allowed by chamfer **60c** causing
25 outwardly-biased retaining member **41c** to be radially depressed upon engagement with abutting edges of circumferential interior groove profiles **22a, 22b** in tubing liner **12**, thereby allowing passage of sand screen sub **41c** downhole past said circumferential interior groove profiles **22a, 22b** in tubing liner **12** and allow sand screen sub **41c** to flow downhole to a

position abutting actuation member **30c** and where screen mesh **55c** thereof underlies opened frac port **16c**. Any subsequent uphole displacement of sand screen sub **41c** from the aforesaid position is prevented by flat face **59c** engaging, directly or indirectly, annular region **50c** in tubing liner **12**, namely by contacting an uphole edge of annular region **50c**, as shown in **Fig. 14**.

Thereafter, as may be seen from the subsequent configuration of the system/method **10** depicted in **Fig. 4A**, one of either two things has occurred—either a pulse of high pressure fluid has been applied to the uphole side of a frangible disk **53c** of sand screen sub **40c** so as to cause disk **53c** to rupture and disintegrate, or if disk **53c** is of a dissolvable type upon application of a corrosive fluid (not shown), a corrosive fluid has been flowed downhole to dissolve disk **53c**.

The same system and series of steps in the method **10** is provided/ carried out for installing sand screen subs **40b**, and subsequently **40a**, in positions underlying then-opened uphole frac/production ports, such as frac production ports **16b** and **16a**, respectively, as depicted in remaining **Figs. 5-10**.

Specifically, **Fig. 5** shows a further successive step in the system/method **10**, wherein a second actuation member **30b** [as best shown in enlarged (perspective) view in **Fig. 15c** and in enlarged cross-sectional view in **Fig. 15d**] and having a frangible burst disk or a dissolvable disk **33b** at an uphole side thereof, is flowed down tubing liner **12** and through discrete section **14a** to discrete section **14b** by applying a pressurized fluid to an uphole side of actuation member **30b**. Due to radially outwardly biased protuberance **31b** having a unique profile/width **W₁** which only matingly engages the interior circumferential groove profile **22b** of similar or greater width **W₁** on most downhole section **14b**, only sliding sleeve member **18b** is engaged by actuation member **30b**. Circled area ‘A’, shown in enlarged view in **Fig. 11**, depicts shear member **20b**, prior to being sheared, securing sliding sleeve member **18b** to tubular liner segment **14b**, and shows annular groove **39** in sliding sleeve member **18b** having bevelled edge **39’** thereon to allow the radially outwardly biased protuberance **31b** of actuation member **30c** to pass over annular groove **39** and engage interior circumferential groove profile **22b** on sliding sleeve member **18b**.

Similar to the configuration of sliding sleeve member **18c**, a downhole end of sliding sleeve member **18b** comprises a plurality of longitudinally-extending collet fingers **43b**, radially outwardly biased, each adapted at distal ends **43'** thereof to matingly engage with at least one annular circumferential ring **44** on tubular liner **12**, when slidable sleeve member **18b** is moved to the open position uncovering frac/production port **16b** (see **Fig. 6**, as described below). When sliding sleeve member **18b** is initially in the closed position, distal ends **43'** thereof may matingly engage a more uphole annular circumferential ring **45**. In such manner the shearable member **20b** is assisted in the temporary securement of slidable sleeve member **18b** to discrete section **14b** of tubing liner **12**.

As may be seen from the subsequent configuration of the system/method **10** depicted in **Fig. 6**, continued injection of pressurized fluid within tubing liner **12** has caused continued force to be applied to an uphole side of actuation member **30b**, namely against frangible burst disk or a dissolvable disk **33b** thereof, causing actuation member **30b** which is lockingly engaged with sliding sleeve member **18b** to together slidably move downhole whereby frac/production port **16b** becomes uncovered and thus opened to fluid communication with interior bore **13** of tubing liner **12**. Similar to the configuration shown in **Fig. 13** in regard to sliding sleeve member **18c**, the plurality of collet fingers **43b** on sliding sleeve member **18b**, at the distal end **43'** thereof, has due to downhole displacement of slidable sleeve member **18b** matingly engaged annular circumferential ring **45** in tubular liner **12**. Similar to the configuration shown in **Fig. 13** as regards sliding member **18c**, sliding sleeve member **18b** has accordingly then been lockingly fixed in position and prevented from not only further progression downhole but also from returning to a closed position covering frac port **16b**.

Further fracking of the reservoir, at the particular location of the now-opened frac port **16b**, is carried out at this point in the method/system **10**.

Thereafter, as may be seen from the subsequent configuration of the system/method **10** depicted in **Fig. 6A**, one of either two things has occurred-either a pulse of high pressure fluid has been applied to the uphole side of a frangible disk **33b** of actuation member **30b** so as to cause disk **33b** to rupture and disintegrate, or if disk **33b** is of a dissolvable type upon

application of a corrosive fluid (not shown), a corrosive fluid has been flowed downhole to dissolve disk **33b**.

As may be seen from the subsequent configuration of the system/method **10** depicted in **Fig. 7**, a sand screen sub **40b** (identical to sand screen sub **40c**, as depicted in area “**D**” of **Fig. 4** and in enlarged view in **Fig. 14**) has been flowed downhole in tubing liner **12** and come to rest against actuation member **30b** which is now lockingly engaged with tubing liner **12**.

Sand screen sub **40b** likewise comprises a cylindrical hollow portion **51b**, having at an uphole end thereof a dissolvable plug member or burst plate **53b**, which at least for a limited time substantially obstructs passage of fluid within interior bore **13** and causes pressurized fluid injected downhole in tubing liner **12** to force sand screen sub **51b** downhole into a position abutting an uphole end of actuation member **30b**.

Importantly, sand screen sub **40b** is provided with a cylindrical, longitudinally extending oil-permeable screen mesh **55b** forming part of an outer periphery thereof. Screen mesh **55b** when sand screen sub **40b** is flowed into the above position abutting actuation member **30b**, prevents ingress of sand into interior bore **13** of tubing liner **12** but permits ingress of oil from a hydrocarbon formation (not shown) into interior bore **13** of tubing liner **12** via opened frac port **16b**.

When sand screen sub **40b** is flowed into position as shown in **Fig. 7**, namely whereby screen mesh **55b** underlies opened frac port **16b**, a resiliently outwardly-biased retaining member **41b** extends radially outwardly into an annular region **50b** formed within tubing liner **12**, thereby then preventing any subsequent uphole displacement of sand screen sub **40b** within tubing liner **12**.

Similar to the configuration shown in **Fig. 14** as regards sand screen sub **40c**, as regards sand screen sub **40b**, retaining member **41b** thereon is provided with a chamfer **60b** on a downhole side edge thereof and a substantially flat face **59b** on an uphole side edge thereof perpendicularly disposed to a longitudinal axis **70** of tubular liner **12**. Downhole movement of sand screen sub **40b** within tubing liner **12** is thereby allowed by chamfer **60b** causing outwardly-biased retaining member **41b** to be radially depressed upon engagement

with abutting edges of circumferential interior groove profile **22a** in tubing liner **12**, thereby allowing passage of sand screen sub **41b** downhole past said circumferential interior groove profile **22a** in tubing liner **12** and allow sand screen sub **41b** to flow downhole to a position abutting actuation member **30b** and where screen mesh **55b** thereof underlies opened frac port
5 **16b**. Any subsequent uphole displacement of sand screen sub **41b** from the aforesaid position is prevented by flat face **59b** engaging, directly or indirectly, annular region **50b** in tubing liner **12**, namely by contacting an uphole edge of annular region **50b**, as shown in **Fig. 7**.

Thereafter, as may be seen from the subsequent configuration of the system/method **10** depicted in **Fig. 7A**, one of either two things has occurred—either a pulse of high pressure
10 fluid has been applied to the uphole side of a frangible disk **53b** of sand screen sub **40b** so as to cause disk **53b** to rupture and disintegrate, or if disk **53b** is of a dissolvable type upon application of a corrosive fluid (not shown), a corrosive fluid has been flowed downhole to dissolve disk **53b**.

Fig. 8 shows a further successive step in the system/method **10**, wherein a third
15 actuation member **30a** [as best shown in enlarged (perspective) view in **Fig. 15e** and in enlarged cross-sectional view in **Fig. 15f**] and having a frangible burst disk or a dissolvable disk **33a** at an uphole side thereof, is flowed down tubing liner **12** and to discrete section **14a** by applying a pressurized fluid to an uphole side of actuation member **30a**. Due to radially outwardly biased protuberance **31a** having a unique profile/width W_0 which only matingly
20 engages the interior circumferential groove profile **22a** of width W_1 , only sliding sleeve member **18a** is engaged by actuation member **30a**. Circled area ‘A’, shown in enlarged view in **Fig. 11**, depicts shear member **20a**, prior to being sheared, securing sliding sleeve member **18a** to tubular liner segment **14a**, and shows annular groove **39** in sliding sleeve member **18a** having bevelled edge **39’** thereon to allow the radially outwardly biased protuberance **31a** of
25 actuation member **30a** to pass over annular groove **39** and engage interior circumferential groove profile **22a** on sliding sleeve member **18a**.

Similar to the configuration of sliding sleeve member **18b** and **18c**, a downhole end of sliding sleeve member **18a** comprises a plurality of longitudinally-extending collet fingers **43a**, radially outwardly biased, each adapted at distal ends **43’** thereof to matingly engage with at

least one annular circumferential ring **44** on tubular liner **12**, when slidable sleeve member **18a** is moved to the open position uncovering frac/production port **16a** (see **Fig. 9**, as described below). When sliding sleeve member **18a** is initially in the closed position, distal ends **43'** thereof may matingly engage a more uphole annular circumferential ring **45**. In such manner
5 the shearable member **20a** is assisted in the temporary securement of slidable sleeve member **18a** to discrete section **14a** of tubing liner **12**.

As may be seen from the subsequent configuration of the system/method **10** depicted in **Fig. 9**, continued injection of pressurized fluid within tubing liner **12** has caused continued force to be applied to an uphole side of actuation member **30a**, namely against frangible burst
10 disk or a dissolvable disk **33a**, causing actuation member **30a** which is lockingly engaged with sliding sleeve member **18a**, to together slidably move downhole whereby frac/production port **16a** becomes uncovered and thus opened to fluid communication with interior bore **13** of tubing liner **12**. Similar to the configuration shown in **Fig. 13** in regard to sliding sleeve member **18c**, the plurality of collet fingers **43a** on sliding sleeve member **18a**, at the distal end
15 **43'** thereof, has due to downhole displacement of slidable sleeve member **18a** matingly engaged annular circumferential ring **45** in tubular liner **12**. Similar to the configuration shown in **Fig. 13** as regards sliding member **18c**, sliding sleeve member **18a** has accordingly then been lockingly fixed in position and prevented from not only further progression downhole but also from returning to a closed position covering frac port **16a**.

20 Further fracking of the reservoir, at the particular location of the now-opened frac port **16a**, is carried out at this point in the method/system **10**.

Thereafter, as may be seen from the subsequent configuration of the system/method **10** depicted in **Fig. 9A**, one of either two things has occurred—either a pulse of high pressure fluid has been applied to the uphole side of a frangible disk **33a** of actuation member **30a** so
25 as to cause disk **33a** to rupture and disintegrate, or if disk **33a** is of a dissolvable type upon application of a corrosive fluid (not shown), a corrosive fluid has been flowed downhole to dissolve disk **33a**.

As may be seen from the subsequent configuration of the system/method **10** depicted in **Fig. 10**, a sand screen sub **40a** (identical to sand screen sub **40c** as depicted in area “**D**” of **Fig. 4** and in enlarged view in **Fig. 14**), and as shown in **Fig. 16a** (perspective view) and in **Fig. 16b** (cross-section) has been flowed downhole in tubing liner **12** and come to rest against
5 actuation member **30a** which is now lockingly engaged with tubing liner **12**.

As best seen from **Figs. 16a, 16b**, sand screen sub **40a** likewise comprises a cylindrical hollow portion **51a**, having at an uphole end thereof a dissolvable plug member or burst plate **53a**, which at least for a limited time substantially obstructs passage of fluid within interior bore **13** and causes pressurized fluid injected downhole in tubing liner **12** to force
10 sand screen sub **51b** downhole into a position abutting an uphole end of actuation member **30a**.

Importantly, sand screen sub **40a** is provided with a cylindrical, longitudinally extending oil-permeable screen mesh **55a** forming part of an outer periphery thereof. Screen mesh **55a** when sand screen sub **40a** is flowed into the above position abutting actuation
15 member **30a**, prevents ingress of sand into interior bore **13** of tubing liner **12** but permits ingress of oil from a hydrocarbon formation (not shown) into interior bore **13** of tubing liner **12** via opened frac port **16a**.

When sand screen sub **40a** is flowed into position as shown in **Fig. 10**, namely whereby screen mesh **55a** underlies opened frac port **16a**, a resiliently outwardly-biased retaining member **41a** extends radially outwardly into an annular region **50a** formed within
20 tubing liner **12**, thereby then preventing any subsequent uphole displacement of sand screen sub **40a** within tubing liner **12**.

Similar to the configuration shown in **Fig. 14** as regards sand screen sub **40c**, as regards sand screen sub **40a**, retaining member **41a** thereon is provided with a chamfer **60a** on
25 a downhole side edge thereof and a substantially flat face **59a** on an uphole side edge thereof perpendicularly disposed to a longitudinal axis **70** thereof and of tubular liner **12**. Downhole movement of sand screen sub **40a** within tubular liner **12** is thereby allowed by chamfer **60a** causing outwardly-biased retaining member **41a** to be radially depressed upon engagement

with any abutting edges of circumferential interior groove profiles in tubing liner **12**, thereby allowing passage of sand screen sub **41a** downhole past said circumferential interior groove profiles in tubing liner **12** and allowing sand screen sub **41a** to flow downhole to a position abutting actuation member **30a** and where screen mesh **55a** thereof underlies opened frac port **16a**. Any subsequent uphole displacement of sand screen sub **41a** from the aforesaid position is prevented by flat face **59a** engaging, directly or indirectly, annular region **50a** in tubing liner **12**, namely by contacting an uphole edge of annular region **50a** as shown in **Fig. 10**.

A pulse of high pressure fluid has been applied to the uphole side of a frangible disk **53a** of sand screen sub **40a** so as to cause disk **53a** to rupture and disintegrate, or if disk **53a** is of a dissolvable type upon application of a corrosive fluid (not shown), a corrosive fluid has been flowed downhole to dissolve disk **53a**.

Production from the tubing liner may then proceed, as shown in **Fig. 10** via all opened frac/production ports **16a, 16b, 16c**, each of which is provided with an underlying respective screen sub **40a, 40b, 40c**, with a respective screen mesh **55a, 55b, 55c** immediately underlying the respective frac/production port **16a, 16b, 16c**.

Operation of the Method/System 10 depicted in Figs. 1-10

The first step of the system/method of **Fig. 1-10**, as shown in **Fig. 1**, comprises locating a tubular liner **12** having:

- a hollow interior bore **13**;
- a plurality of frac ports **16a, 16b, 16c** spaced along a periphery of tubular liner **12**;
- a corresponding plurality of sliding sleeve members **18a, 18b, 18c** respectively initially covering each of said frac ports **16a, 16b, 16c**;

Within a wellbore (not shown)

The second step of the method of **Fig. 1-10** is depicted as a series of sub-steps shown in **Figs. 2-3A**, and comprises;

-situating a first actuation member **30c** having a resiliently outwardly biased protuberance **31c** of a first profile **W2**, within said tubular liner **12**; and applying a pressurized fluid to an uphole end of said first actuation member **30c** and causing said first actuation member **30c** to flow downhole and to a position in
 5 said tubular liner **12** where said radially outwardly-biased protuberance **31c** thereon engages a mating profile **22c** on sliding sleeve member **18c** (**Fig. 2**);

- continuing to apply said pressurized fluid to said tubular liner **12** and causing said one sliding sleeve member **18c** and actuation member **30c** to together move
 10 downhole and uncover and thereby open an associated of said frac ports **16c** in said tubular liner **12** and thereby allow fluid communication from said interior bore **13** to an exterior of said tubular liner **12** via the opened associated frac port **16c**, and injecting a fracking fluid under pressure into said tubular liner **12** and causing said frac fluid to flow into the hydrocarbon formation via the opened
 15 frac port (**Fig. 3**); and

-introducing a fracking fluid (not shown) under still higher pressure, or injecting a corrosive fluid, so as to burst or dissolve, respectively a plug member **33c** on an uphole side of actuation member **30c** (**Fig. 3A**).

A subsequent step in the system/method **10**, as shown in **Fig. 4 & 4A**,
 20 comprises:

inserting a first sand screen sub **30c** into said tubular liner **12**, said first sand screen sub **30c** having:

- a resiliently-outwardly biased protuberance **41c** having a given profile; and
- an annular screen mesh **55c** about an outer periphery of said first sand screen

25 sub **40c**; and

applying a pressurized fluid to an uphole end of first sand screen sub **40c** and causing the first sand screen sub **40c** to flow downhole to a position in said tubular liner **12**

where said annular screen mesh **55c** thereof underlies the open frac port **16c** and causing said profile of said resiliently-outwardly biased protuberance **41c** thereon to engage a mating profile **50c** on an interior of said tubular liner **12**, namely an annular region **50c** thereof, so as to retain the first sand screen sub **40c** in a position where the annular screen mesh **55c** thereof underlies said open frac port **16c**.

The above steps of the method described may be repeated using a second actuation member **30b** to open uphole frac/production port **16b** and insert a second sand screen sub **40b** immediately underlying the opened frac/production port **16b**, as shown in **Figs.5-7A**, varying only that the second actuation member **30b** used has a radially outwardly biased protuberance **31b** thereon of a width **W1**, where width $W1 < W2$, so as to only engage a corresponding interior circumferential groove profile **22b** on a corresponding sliding sleeve member **18b**.

Likewise, the above steps may be repeated to open a further uphole frac/production port **16a** using a third actuation member **30a** and insert a third sand screen sub **40a** immediately underlying the opened frac/production port **16a**, as shown in remaining **Figs.8-10**, varying only that a third actuation member **30a** used has a radially outwardly biased protuberance **31a** thereon of a width **W0**, where width $W0 < W1$, so as to only engage a corresponding interior circumferential groove profile **22a** on a corresponding sliding sleeve member **18a**.

20 Description of Related Method/System 100

Figs.17-24A depict successive steps and configuration of a related but somewhat different method/system **100** of the present invention.

Specifically, method/system **100** like method/system **10** utilizes not only a plurality of configurationally-different actuation members **30a**, **30b**, **30c** as per method/system **10**, but in addition utilizes a corresponding plurality of configurationally-different sand screen subs **140a**, **140b**, and **140c**.

As seen from **Fig. 17**, the tubular liner **12** of method/system **100** comprises, like method/system **10**, a plurality of individually different segments **114a**, **114b**, and **114c**, each

with a corresponding frac/production port **16a**, **16b**, **16c**. Similar to method/system **10**, each discrete segment **114a**, **114b**, **114c**, has a slidable sleeve member **18a**, **18b**, **18c** wherein the interior circumferential groove profile **22a**, **22b**, **22c** of each is of a different width/profile **W0**, **W1**, **W2**, where $W0 < W1 < W2$, with the most downhole interior circumferential groove profile **22c** on the most downhole sliding sleeve member **18c** being the largest width.

Notably, however, in comparison to the discrete segments **14a**, **14b**, **14c** of method/system **10**, discrete segments **114a**, **114b**, and **114c** of the method/system **100** are configurationally different in region “**q**”, “**r**”, and “**s**”, to provide the advantage of being able to individually matingly engage particular sand screen subs **140a**, **140b**, and **140c** at a particular desired location along tubular liner **12**, in the manner hereinafter explained and depicted in **Figs. 20**, **22**, and **24**.

Fig. 18 shows a further successive step in the system/method **100**, where an actuation member **30c** having a radially outwardly biased protuberance **31c** thereon of width/profile **W2**, is flowed down tubing liner **12**, until radially outwardly biased protuberance **31c** thereon matingly engages interior circumferential groove profile **22c** on corresponding sliding sleeve member **18c**.

Fig. 19 shows a further successive step in the system/method **100**, where actuation member **30c**, due to fluid pressure being supplied at an uphole side thereof, is caused along with corresponding slidable sleeve member **18c** to be forced downhole, thereby causing frac/production port **16c** to be opened and collet fingers **43c** on sliding sleeve member to lockingly engage annular ring **44** on tubular liner **12**. Notably, by sliding sleeve member **18c** being repositioned in tubing liner **12** in the aforementioned manner, an annular region **50c** is thereby created immediately below opened frac/production **16c**, of a width “**X2**”.

Fig. 19A shows a further successive step in the system/method **100**, where one of either two things has occurred—either a pulse of high pressure fluid has been further applied to the uphole side of a frangible disk **33c** of actuation member **30c** so as to cause disk **33c** to rupture and disintegrate, or if disk **33c** is of a dissolvable type upon application of a corrosive fluid (not shown), a corrosive fluid has been flowed downhole to dissolve disk **33c**.

Fig. 20 shows a further successive step in the system/method **100**, where a first sand screen sub **140c**, as best seen in **Figs. 25a, 25b**, has been flowed downhole in tubing liner **12**, and a radially outwardly biased retainer member **141c** thereof, of width **X2**, has become lockingly engaged in annular region **50c** of tubular liner **12**, of similar width **X2**.

5 **Fig. 20A** shows a further successive step in the system/method **100**, where one of either two things has occurred—either a pulse of high pressure fluid has been further applied to the uphole side of a frangible disk **53c** of sand screen sub **140c** so as to cause disk **33c** to rupture and disintegrate, or if disk **53c** is of a dissolvable type upon application of a corrosive fluid (not shown), a corrosive fluid has been flowed downhole to dissolve disk **53c**.

10 **Fig. 21** shows a further successive step in the system/method **100**, where a second actuation member **30b** having a radially outwardly biased protuberance **31b** thereon of width/profile **W1**, where $W1 < W2$, is flowed down tubing liner **12** until radially outwardly biased protuberance **31b** thereon matingly engages interior circumferential groove profile **22b** of similar profile/width **W1** on corresponding sliding sleeve member **18b**.

15 **Fig. 21A** shows a further successive step in the system/method **100**, where one of either two things has occurred—either a pulse of high pressure fluid has been further applied to the uphole side of a frangible disk **33b** of second actuation member **30b** so as to cause disk **33b** to rupture and disintegrate, or if disk **33b** is of a dissolvable type upon application of a corrosive fluid (not shown), a corrosive fluid has been flowed downhole to dissolve disk **33b**.

20 **Fig. 22** shows a further successive step in the system/method **100**, where a second sand screen sub **140b**, as best seen in **Figs. 25c, 25d**, has been flowed downhole in tubing liner **12** and a radially outwardly biased retainer member **141b** thereof, of width **X1**, has become lockingly engaged in annular region **50b** of tubular liner **12**, of similar width **X1**.

25 **Fig. 22A** shows a further successive step in the system/method **100**, where one of either two things has occurred—either a pulse of high pressure fluid has been further applied to the uphole side of a frangible disk **53b** of sand screen sub **140b** so as to cause disk **33b** to rupture and disintegrate, or if disk **53b** is of a dissolvable type upon application of a corrosive fluid (not shown), a corrosive fluid has been flowed downhole to dissolve disk **53b**.

Fig. 23 shows a further successive step in the system/method **100**, where a third actuation member **30a** having a radially outwardly biased protuberance **31a** thereon of width/profile **W0**, where $W0 < W1$, is flowed down tubing liner **12** until radially outwardly biased protuberance **31a** thereon matingly engages interior circumferential groove profile **22a** of similar profile/width **W0** on corresponding sliding sleeve member **18a**.

Fig. 23A shows a further successive step in the system/method **100**, where one of either two things has occurred—either a pulse of high pressure fluid has been further applied to the uphole side of a frangible disk **33c** of third actuation member **30c** so as to cause disk **33c** to rupture and disintegrate, or if disk **33c** is of a dissolvable type upon application of a corrosive fluid (not shown), a corrosive fluid has been flowed downhole to dissolve disk **33c**.

Fig. 24 shows a further successive step in the system/method **100**, where a third sand screen sub **140a**, as best seen in **Figs. 25e, 25f**, has been flowed downhole in tubing liner **12** and a radially outwardly biased retainer member **141a** thereof, of width **X0**, has become lockingly engaged in annular region **50a** of tubular liner **12**, of similar width **X0**.

Fig. 24A shows a further successive step in the system/method **100**, where one of either two things has occurred—either a pulse of high pressure fluid has been further applied to the uphole side of a frangible disk **53a** of sand screen sub **140a** so as to cause disk **33a** thereof to rupture and disintegrate, or if disk **53c** is of a dissolvable type upon application of a corrosive fluid (not shown), a corrosive fluid has been flowed downhole to dissolve disk **53c**.

Description of Related Method/System 200

Figs. 25-30a depict successive steps and configuration of a related method/system **200** of the present invention.

Specifically, method/system **200** similar to method/system **100** utilizes a plurality of configurationally-different sand screen subs **140a, 140b, and 140c**, but in contrast to either of aforementioned methods/systems **10, 100**, utilizes only one actuation member **30c** having a radially outwardly biased protuberance **31c** of profile/width **W2** thereon to actuate a plurality of sliding sleeve members **18c**, each having an interior circumferential groove profile

22c of a similar width/profile **W2**, and thereby open a plurality (cluster) of frac/production ports **16a**, **16b**, and **16c** within respective discrete segments **214a**, **214b**, **214c** of tubing liner **12**.

As firstly seen from **Fig. 26**, the tubular liner **12** of method/system **200** comprises, like method/system **100**, a plurality of individually different segments **214a**, **214b**, and **214c**, each with a corresponding frac/production port **16a**, **16b**, **16c**. Each discrete segment **214a**, **214b**, **214c**, however, has a slidable sleeve member **18a**, **18b**, **18c** having a respective interior circumferential groove profile **22a**, **22b**, **22c** all of a consistent width/profile **W2**.

Notably, however, in comparison to the discrete segments **14a**, **14b**, **14c** of method/system **10**, discrete segments **214a**, **214b**, and **214c** of the method/system **200** are configurationally different in region “**q**”, “**r**”, and “**s**”, to provide the advantage of being able to individually and uniquely matingly engage individual sand screen subs **140a**, **140b**, and **140c** at a particular desired location along tubular liner **12**, in the manner hereinafter explained and depicted in **Figs. 28, 29, and 30, 22, and 24**.

Fig. 27 shows a further successive step in the system/method **200**, where a single actuation member **30** having a radially outwardly biased protuberance **31c** thereon of width/profile **W2**, is flowed down tubing liner **12**, until radially outwardly biased protuberance **31c** thereon of profile/width **W2** matingly engages interior circumferential groove profile **22a** on corresponding sliding sleeve member **18a**, and slidably moves sliding sleeve member **22a** downhole to thereby uncover/open frac/production port **16a**. Annular region **50a**, of width **X0**, is thereby created in tubular liner **12**.

Due to a chamfer **220** expressly provided on a downhole side edge of protuberance **31c** of actuation member **30**, upon continued further fluid pressure applied to an uphole side of said actuation member **30**, chamfer **220** contacts a downhole side edge of the circumferential groove profile **22a** in sliding sleeve member **18a** and the radially-outwardly biased protuberance **31c** thereafter becomes radially inwardly depressed and thereby disengaged from mating engagement with said interior circumferential groove **22a**, thereby allowing actuation member **30** to continue moving downhole to engage interior

circumferential groove profile **22b** on corresponding sliding sleeve member **18b**, and slidably move sliding sleeve member **22b** downhole to similarly uncover/open frac production port **16b**. Annular region **50b**, of width **X1**, is thereby created in tubular liner **12**.

Again, due to a chamfer **220** provided on a downhole side edge of protuberance **31c** of actuation member **30**, upon continued further fluid pressure applied to an uphole side of said actuation member **30**, chamfer **220** contacts a downhole side edge of the circumferential groove profile **22b** in sliding sleeve member **18b** and the radially-outwardly biased protuberance **31c** thereafter becomes radially inwardly depressed and thereby disengaged from mating engagement with said interior circumferential groove **22a**, thereby allowing actuation member **30** to continue moving downhole to engage interior circumferential groove profile **22c** on corresponding sliding sleeve member **18c**, and slidably move sliding sleeve member **18c** downhole to similarly uncover/open frac production port **16c**. Annular region **50c**, of width **X2**, is thereby created in tubular liner **12**.

The resulting configuration of the tubular liner is as per that depicted in **Fig. 27**.

When sliding sleeve member **18a**, **18b**, **18c** are moved so as to uncover respective frac/production ports **16a**, **16b**, **16c**, collet fingers **43** on sliding sleeve members **18a**, **18b**, **18c** are moved downhole, such that distal ends **43'** thereof matingly engage annular ring **44** in tubular liner **12**, as shown in region "E" of **Fig. 27** and in enlarged view in **Fig. 32**, thereby preventing sliding sleeve members **18a**, **18b**, **18c** from further movement.

Fig. 27a shows a further successive step in the system/method **200**, where one of either two things has occurred-either a pulse of high pressure fluid has been further applied to the uphole side of a frangible disk **33c** of actuation member **30** so as to cause disk **33c** to rupture and disintegrate, or if disk **33c** is of a dissolvable type upon application of a corrosive fluid (not shown), a corrosive fluid has been flowed downhole to dissolve disk **33c**.

Fig. 27b depicts an optional step in the method/system **200**, for a situation where the entire actuation member **30** has been made dissolvable, and a corrosive fluid has been flowed downhole to dissolve actuation member **30**.

Remaining **Figs. 28-30a** depict a configuration where actuation member **30** has been made dissolvable, and a corrosive fluid has been flowed downhole to dissolve actuation member **30**, and actuation member **30** no longer remains. Of course, if actuation member **30** has not been made dissolvable, actuation member **30** and the optional step of **Fig. 27b** not carried out, actuation member **30** would remain in the most downhole segment **214c** in each of remaining **Figs. 28-30a**.

Fig. 28 shows a further successive step in the system/method **200**, where a first sand screen sub **140c**, as best seen in **Figs.25a, 25b**, has been flowed downhole in tubing liner **12**, and a radially outwardly biased retainer member **141c** thereof, of width **X2**, has become lockingly engaged in annular region **50c** of tubular liner **12**, of similar width **X2**.

Fig. 28a shows a further successive step in the system/method **200**, where one of either two things has occurred-either a pulse of high pressure fluid has been further applied to the uphole side of a frangible disk **53c** of sand screen sub **140c** so as to cause disk **53c** thereof to rupture and disintegrate, or if disk **53c** is of a dissolvable type upon application of a corrosive fluid (not shown), a corrosive fluid has been flowed downhole to dissolve disk **53c**.

Fig. 29 shows a further successive step in the system/method **200**, where a second sand screen sub **140b**, as best seen in **Figs.25c, 25d**, has been flowed downhole in tubing liner **12**, and a radially outwardly biased retainer member **141b** thereof, of width **X1**, has become lockingly engaged in annular region **50b** of tubular liner **12**, of similar width **X1**.

Fig. 29a shows a further successive step in the system/method **200**, where one of either two things has occurred-either a pulse of high pressure fluid has been further applied to the uphole side of a frangible disk **53b** of sand screen sub **140b** so as to cause disk **53b** thereof to rupture and disintegrate, or if disk **53b** is of a dissolvable type upon application of a corrosive fluid (not shown), a corrosive fluid has been flowed downhole to dissolve disk **53b**.

Fig. 30 shows a further successive step in the system/method **200**, where a third sand screen sub **140a**, as best seen in **Figs.25e, 25f**, has been flowed downhole in tubing liner **12**, and a radially outwardly biased retainer member **141a** thereof, of width **X0**, has become lockingly engaged in annular region **50a** of tubular liner **12**, of similar width **X0**.

Fig. 30a shows a further successive step in the system/method **200**, where one of either two things has occurred—either a pulse of high pressure fluid has been further applied to the uphole side of a frangible disk **53a** of sand screen sub **140a** so as to cause disk **53a** thereof to rupture and disintegrate, or if disk **53a** is of a dissolvable type upon application of a corrosive fluid (not shown), a corrosive fluid has been flowed downhole to dissolve disk **53a** thereof.

Description of Related Method/System 300

Figs. 31a-31f depict successive steps and configuration of a related method/system **300** of the present invention.

The method/system **300** shown in **Figs. 31a-31f** differs from the method/system **200** in that instead of using a burst plate disk or dissolvable disk **53c** at an uphole end of actuation member **30**, actuation member **30** has a sealing surface **302** against which a dissolvable ball member **301** may sealingly engage, to thereby serve as a dissolvable plug and allow actuation member **30** to be flowed downhole to actuate (open) corresponding slidable sleeve members **18a, 18b, 18c** and thus frac/production ports **16a, 16b, 16c**.

Fig. 31a shows a tubular liner **12** of method/system **300** comprising a plurality of individually different segments **214a, 214b, and 214c**, each with a corresponding frac/production port **16a, 16b, 16c**. Each discrete segment **214a, 214b, 214c**, however, has a slidable sleeve member **18a, 18b, 18c** having a respective interior circumferential groove profile **22a, 22b, 22c** all of a consistent width/profile **W2**.

Discrete segments **214a, 214b, and 214c** of the method/system **300** are configurationally different, to provide the advantage of being able to individually and uniquely matingly engage individual sand screen subs **140a, 140b, and 140c** at a particular desired location along tubular liner **12**, in the manner as shown in **Fig. 31d**.

Fig. 31b shows a further successive step in the system/method **300**, where a single actuation member **30** having a radially outwardly biased protuberance **31c** thereon of width/profile **W2**, and a sealing surface **302** for a dissolvable ball **301**, is flowed down tubing liner

12, until radially outwardly biased protuberance **31c** thereon of profile/width **W2** matingly engages interior circumferential groove profile **22a** on corresponding sliding sleeve member **18a**.

Fig. 31c shows actuation member **30** having successively engaged and opened frac/production ports **16a**, **16b**, and **16c**, thereby creating annular regions **50a**, **50b**, **50c** of respective widths X_0 , X_1 , and X_2 immediately underlying the respective opened frac ports **16a**, **16b**, and **16c**.

When sliding sleeve members **18a**, **18b**, **18c** are moved so as to uncover respective frac/production ports **16a**, **16b**, **16c**, collet fingers **43** on sliding sleeve members **18a**, **18b**, **18c** are moved downhole, such that distal ends **43'** thereof matingly engage annular ring **44** in tubular liner **12**, as shown in region "E" of **Fig. 31c** and in enlarged view in **Fig. 32**, thereby preventing sliding sleeve members **18a**, **18b**, **18c** from further movement.

Fig. 31d shows a further successive step in the system/method **300**, where a first sand screen sub **140c**, a second sand screen sub **140b**, and a third sand screen sub **140a**, as best seen in **Figs. 25a**, **25b**, **Figs. 25c**, **25d**, and **Figs. 25e**, **25f** respectively, have each been flowed downhole in tubing liner **12**, and a radially outwardly biased retainer member **141c**, **141b**, and **141a** thereof, of width X_2 , X_1 , and X_0 , respectively, has become lockingly engaged in annular region **50c**, **50b**, and **50a** respectively of tubular liner **12**.

Fig. 31e shows a further successive step in the system/method **300**, where a corrosive fluid has been flowed downhole to dissolve ball member **301**.

Fig. 31f shows a further successive (optional) step in the system/method **300**, where the actuation member **30** has been made dissolvable, and where a corrosive fluid has been flowed downhole to dissolve actuation member **30**.

The foregoing description of the disclosed embodiments and related systems/methods **10**, **100**, **200** and **300** is provided to enable any person skilled in the art to make or use the present invention. The scope of the claims should not be limited by the preferred embodiments set forth in the examples, but should be given the broadest interpretation

consistent with the specification, including the description and drawings, as a whole. Thus, the present invention is not intended to be limited to the embodiments shown herein, but is to be accorded the full scope consistent with the claims.

5 For a complete definition of the invention and its intended scope, reference is to be made to the summary of the invention and the appended claims read together with and considered with the disclosure and drawings herein.

We claim:

1. A system for fracking a hydrocarbon formation at a given location along a wellbore and subsequently allowing installation of a sand screen at said location without having to “trip out” a frac string prior to commencing production, comprising;

5 - a tubular liner insertable within said wellbore and having an interior bore, further comprising:

(a) a plurality of spaced-apart frac ports longitudinally spaced at intervals along said tubular liner, providing, when open, fluid communication between the interior bore of the tubular liner and an exterior of the tubular liner;

10 (b) a corresponding plurality of cylindrical hollow sliding sleeve members, each configured in an initial closed position to cover a corresponding of said frac ports and prevent flow of fluid from the interior bore to an exterior of the tubular liner, and slidably moveable longitudinally in the interior bore to an open position to uncover said corresponding of the frac ports, each sliding sleeve member
15 initially covering a respective of said plurality of frac ports so as to prevent flow of a fluid from within the interior bore to the exterior of the tubular liner, each of the sliding sleeve members having an interior circumferential groove profile therein of a given longitudinal width ; and

20 (c) a plurality of shear members, initially securing respectively said slidable sleeve members to the tubular liner in the initial closed position thereof, and sheareable when a longitudinal force is applied thereto to thereafter allow longitudinal slidable movement of respective of said slidable sleeve members;

- at least one actuation member, insertable within the interior bore of the tubular liner, comprising:

25 (a) a cylindrical hollow collet sleeve, having a radially-outwardly biased protuberance on a periphery thereof having a first profile, said radially-outwardly biased protuberance configured to matingly engage said interior circumferential

groove profile on at least one of the plurality of sliding sleeve members;

(b) a burst plate, dissolvable plug member, or a seating surface configured to provide a sealing surface against which a dissolvable plug member may abut, which burst plate, plug member, or sealing surface in combination with said plug member, at least for a limited time prevents pressurized fluid injected downhole in said interior bore from travelling past said actuation member in said tubular liner thereby allowing said actuation member to be flowed downhole by said pressurized fluid;

- at least one cylindrical sand screen sub, insertable within the interior bore of said tubular liner and displaceable within said tubular liner to a location therein proximate a one of said frac ports in said tubular liner whose corresponding sliding sleeve member has been uncovered by said actuation member, said at least one sand screen sub comprising:

(a) a cylindrical hollow member having at an uphole end thereof a dissolvable plug member or burst plate which at least for a limited time substantially obstructs passage of fluid within said interior bore thereby causing pressurized fluid injected downhole in said bore of said tubular liner to force said sand screen sub downhole in said tubular liner ;

(b) a cylindrical, longitudinally-extending oil-permeable screen mesh forming a portion of an outer periphery of said sand screen sub downhole from said dissolvable plug member or burst plate thereon, which screen mesh when said sand screen sub is located proximate said one of said frac ports, underlies said one of said frac ports and prevents ingress of sand but permits ingress of oil, from said formation into the interior bore via said one of said frac ports; and

(c) a resiliently outwardly biased retaining member, which engages, directly or indirectly, said tubular liner when said sand screen sub has flowed down said tubular liner to said one of said frac ports whose corresponding sliding sleeve member has been opened and to a position within the tubular liner wherein the screen mesh of said sand screen sub underlies said one of said frac ports, which

retaining member after engagement with said tubular liner prevents uphole displacement of said sand screen sub in said tubular liner.

2. The system for fracking a hydrocarbon formation as claimed in claim **1**, which ensures
5 that the sand screen sub may flow downhole to a position underlying a desired opened frac port:

said resiliently outwardly biased retaining member on said at least one sand screen sub has a chamfer on a downhole side edge thereof and a flat face on an uphole side edge thereof perpendicularly disposed to a longitudinal axis of said tubular liner; and

wherein downhole movement of said at least one sand screen sub in said tubular liner is
10 allowed by said chamfer causing said resiliently outwardly biased retaining member to become radially depressed upon fluid pressure being exerted on an uphole side of said sand screen sub ; and

wherein uphole movement of said sand screen sub is prevented, when said screen mesh of said sand screen sub underlies said one of said frac ports, by said flat face engaging, directly
15 or indirectly, an annular region in said tubular liner.

3. The system for fracking a hydrocarbon formation as claimed in claim **1**, wherein each of said sliding sleeve members, and said tubular liner at a location proximate each of said frac ports, have mating engagement means which become respectively lockingly engaged when said
20 sliding sleeve members are each respectively moved so as to uncover a corresponding frac port, which mating engagement means retains said sliding sleeve members, once in said open position, from thereafter returning to a closed position covering said corresponding frac port.

4. The system for fracking a hydrocarbon formation as claimed in claim **3**, wherein the
25 mating engagement means on said sliding sleeve members comprises a plurality of collet fingers, radially outwardly biased, and extending from a downhole end of each sliding sleeve member, and

said mating engagement means on said tubular liner comprises an annular circumferential ring on said tubular liner, which when one of said slidable sleeve members travels to said open position, said collet fingers thereof matingly engage said annular circumferential ring on said sliding sleeve member.

5 **5.** The system for fracking a hydrocarbon formation as claimed in claim 1, wherein:

-said profile of said radially-outwardly biased protuberance on said actuation member comprises a raised collet profile of a width W2; and

10 -said interior circumferential groove profile of given longitudinal width on said one sliding sleeve member is a mating circumferential groove of a width equal to or greater than W2.

6. A system for fracking a hydrocarbon formation as claimed in claim 5, further comprising:
a second actuation member, insertable within the interior bore of the tubular liner, comprising:

15 **(a)** a cylindrical hollow collet sleeve, having a radially-outwardly biased protuberance on a periphery thereof having a second profile of width W1, where $W1 < W2$, said radially-outwardly biased protuberance configured to matingly engage said interior circumferential groove profile on another of the plurality of sliding sleeve members, having a width equal to or greater than W1 but less than
20 W2;

(b) a burst plate, dissolvable plug member, or a seating surface situated at an uphole end of said collet sleeve configured to provide a sealing surface against which a dissolvable plug member may abut, which burst plate, plug member, or plug member and sealing surface are situated at an uphole end of said collet
25 sleeve and at least for a limited time prevent pressurized fluid injected downhole in said interior bore from travelling past said actuation member in said tubular liner;

- a second sand screen sub, insertable within the interior bore of said tubular liner comprising:

5 (a) a cylindrical hollow member having at an uphole end thereof a dissolvable plug member or burst plate which at least for a limited time substantially obstructs passage of fluid within said interior bore thereby causing pressurized fluid injected downhole in said bore of said tubular liner to force said sand screen sub downhole in said tubular liner ;

10 (b) a cylindrical, longitudinally-extending oil-permeable screen mesh forming a portion of an outer periphery of said second sand screen sub downhole from said dissolvable plug member or burst plate thereon, which screen mesh when said sand screen sub is located proximate said one of said frac ports, underlies said one of said frac ports and prevents ingress of sand but permits ingress of oil, from said formation into the interior bore via said one of said frac ports; and

15 (c) a retaining member on said cylindrical hollow member, which engages, directly or indirectly, said tubular liner when said second sand screen sub has flowed down said tubular liner to another of said frac ports whose corresponding sliding sleeve member has been opened on said tubular liner by said second actuation member to a position wherein the screen mesh of said sand screen sub underlies said another of said frac ports, which retaining member after
20 engagement with said tubular liner prevents uphole displacement of said second sand screen sub in said tubular liner.

7. The system for fracking a hydrocarbon formation as claimed in claim 1, wherein:

25 said radially-outwardly biased protuberance on said actuation member is configured such that after matingly engaging said interior circumferential groove profile on at least one of the plurality of sliding sleeve members, such radially-outwardly biased protuberance on said actuation member remains lockingly engaged with said interior circumferential groove profile on said slidable sleeve and said actuation member is thereby prevented from further downhole movement within said tubular liner.

8. The system for fracking a hydrocarbon formation as claimed in claim 7, wherein after said actuation member has moved a most downhole of said sliding sleeves to an open position uncovering said corresponding frac port, and said sand screen sub flowed downhole to underlie the uncovered frac port, further movement of said at least one sand screen sub downhole in said tubing liner is prevented by said sand screen sub abutting said actuation member.

9. The system for fracking a hydrocarbon formation as claimed in claim 1 at a plurality of contiguous locations along a wellbore, wherein:

said radially outwardly-biased protuberance on said actuation member releasibly lockingly engages said interior circumferential groove profile on said one of said sliding sleeve members to allow subsequent downhole movement within said tubular liner.

10. The system for fracking a hydrocarbon formation as claimed in claim 9, wherein:

said radially-outwardly biased protuberance on said actuation member has a chamfer on a downhole side thereof; and

wherein upon said radially-outwardly biased protuberance engaging said interior circumferential groove profile in said at least one sliding sleeve member and said at least one sliding sleeve member being moved downhole to open said desired frac port, and upon continued further fluid pressure applied to an uphole side of said actuation member, said chamfer engages a downhole side edge of the circumferential groove profile and said radially-outwardly biased protuberance thereafter becomes disengaged from mating engagement with said interior circumferential groove thereby allowing said actuation member to continue moving downhole to successively engage one or more additional sliding sleeve members and uncover at least one additional corresponding frac port.

11. The system for fracking a hydrocarbon formation as claimed in claim 10, wherein the at least one sand screen sub comprises a plurality of sand screen subs, and wherein:

the retaining member on each sand screen sub possesses a unique profile or width; and

the tubular liner, proximate each frac port, possesses an annular region of a corresponding unique profile or width;

wherein the retaining member on one of said sand screen subs, when said one of said sand screen subs is flowed down the tubular liner, will only engage the tubular liner at a particular annular region along said tubing liner, and the retaining member thereof after
5 engagement with said annular region prevents longitudinal displacement of said sand screen sub from said position in said tubular liner.

12. The system for fracking a hydrocarbon formation as claimed in claim 1, wherein said at least one sand screen sub comprises a plurality of sand screen subs, and wherein:

10 said retaining member on each sand screen sub is of a unique width relative to a width of a retaining member on another of said sand screen subs; and

wherein a retaining member of width “ X_2 ” on a first sand screen sub inserted downhole is of a greater width than a width X_1 of a retaining member on a second sand screen sub thereafter subsequently inserted downhole in said tubular liner; and

15 said retaining member on said first sand screen sub matingly engages a corresponding annular region in said tubular liner of an equal or greater width X_2 ; and

said retaining member on said second sand screen sub matingly engages a corresponding annular region of width $\geq X_1$ but $< X_2$, located uphole in said tubular liner .

20 **13.** The system for fracking a hydrocarbon formation as claimed in claim 7, 8, or 9 wherein said actuation member is dissolvable upon a corrosive fluid being applied to said interior bore of said tubular liner.

14. A method for conducting a fracking procedure at least one location along a wellbore situated within a hydrocarbon formation, and thereafter installing a sand screen within a tubular

liner within said wellbore to prevent ingress of sand into said tubular liner, comprising the steps of:

(i) locating a tubular liner having:

-a hollow interior bore;

5 - a plurality of frac ports spaced along a periphery of said tubular liner;

- a corresponding plurality of sliding sleeve members respectively initially covering each of said frac ports;

10 within said wellbore;

(ii) situating a first actuation member having a resiliently outwardly biased protuberance of a first profile, within said tubular liner ;

15 (iii) applying a pressurized fluid to an uphole end of said first actuation member and causing said first actuation member to flow downhole and to a position in said tubular liner where said radially outwardly-biased protuberance thereon engages a mating profile on one of said plurality of sliding sleeve members;

20 (iv) continuing to apply said pressurized fluid to said tubular liner and causing said one sliding sleeve member and actuation member to together move downhole and uncover and thereby open an associated of said frac ports in said tubular liner and thereby allow fluid communication from said interior bore to an exterior of said tubular liner and said hydrocarbon formation via the opened associated frac port;

25 (v) injecting a fracking fluid into said tubular liner and causing said frac fluid to flow into the hydrocarbon formation via the opened frac port;

(vi) inserting a first sand screen sub into said tubular liner, said first sand screen sub having:

- a resiliently-outwardly biased protuberance having a given profile;
and

- an annular screen mesh about an outer periphery of said first sand
screen sub; and

5

(vii) applying a pressurized fluid to an uphole end of said first sand screen sub
and causing said first sand screen sub to flow downhole to a position in said
tubular liner where said annular screen mesh thereof underlies said open frac
port and causing said profile of said resiliently-outwardly biased protuberance
thereon to engage a mating profile on an interior of said tubular liner and thereby
retain said first sand screen sub in a position wherein the annular screen mesh
thereof underlies said open frac port.

10

15. The method as claimed in claim **14**, further comprising the step, after step **(iv)** or step
(v), of injecting pressurized fluid into said interior bore at a pressure sufficient to rupture a burst
disk member located on said actuation member, so as to thereafter allow fluid to flow through
said actuation member.

15

16. The method as claimed in claim **14**, further comprising the step after step **(vii)** of injecting
pressurized fluid into said interior bore at a pressure sufficient to rupture a burst disk member
located on said sand screen member, so as to thereafter allow fluid to flow through said sand
screen member .

20

17. The method as claimed in claim **14**, further comprising the step at some time after step
(iv) of dissolving a plug member in said actuation member to allow subsequent flow of fluid
through said actuation member after said actuation member has moved said sliding sleeve
downhole and thereby opened said associated frac port.

25

18. The method as claimed in claim **17**, wherein said step of dissolving said plug member further comprises flowing a corrosive fluid down said tubular liner to said actuation member.

19. The method as claimed in claim **14**, further comprising the step after step **(vii)** of exposing said sand screen sub to a corrosive fluid so as to dissolve a portion of said sand screen sub so as to thereafter allow fluid to flow longitudinally through said sand screen sub.

20. The method as claimed in claim **14**, further comprising the step at some time after step **(iv)** of flowing a corrosive fluid into said interior bore and causing said actuation member to dissolve.

21. The method as claimed in claim **14**, wherein when said first actuation member engages said one sliding sleeve member and moves said sliding sleeve member to said open position, causing said actuation member to lockingly engage said sliding sleeve member, and said sliding sleeve member to further lockingly engage said tubing liner, thereby preventing further movement of said actuation member within said tubing liner.

22. The method as claimed in claim **14** for further conducting a fracking procedure at a plurality of spaced apart locations along said wellbore and installing sand screens within the tubular liner at each of said plurality of locations to prevent ingress of sand into the tubular liner at each of said locations, wherein after step **(vii)** such method further comprises carrying out the following further steps:

(viii) situating a second actuation member having a resiliently-outwardly biased protuberance of a second profile thereon different than said first profile, within said tubular liner ;

(x) applying a pressurized fluid to an uphole end of said second actuation member and causing said second actuation member to flow downhole and to a position in said tubular

liner where said second profile on said second actuation member engages a corresponding mating profile on a further one of said sliding sleeve members;

5 (xi) continuing to apply said pressurized fluid to said tubular liner and causing said second actuation member and said further one of sliding sleeve member to together move downhole and uncover and thereby open a further associated of said frac ports in said tubular liner and thereby allow fluid communication from said interior bore to an exterior of said tubular liner and said hydrocarbon formation via the further opened frac port;

10 (xiv) injecting a fracking fluid into said tubular liner and causing said frac fluid to flow into the hydrocarbon formation via the further opened frac port;

(xv) situating a second sand screen sub within said tubular liner, said second sand screen sub having a resiliently-outwardly biased protuberance thereon and an annular screen mesh about an outer periphery thereof; and

15 (xvi) applying a pressurized fluid to an uphole end of said second sand screen sub and causing said second sand screen sub to flow downhole to a position in said tubular liner where said screen mesh thereon underlies said further opened frac port, and causing said resiliently-outwardly biased protuberance on said second sand screen sub to engage a mating profile on an interior of said tubular liner proximate said further opened frac port
20 so as to thereby retain said second sand screen sub and said annular screen mesh thereof underlying said further opened frac port .

23. The method as claimed in claim 22, wherein said resiliently-outwardly biased protuberance of said first actuation member is of a width W_2 , and said resiliently-outwardly biased protuberance
25 of said second actuation member is of a width W_1 , wherein $W_1 < W_2$.

24. A method for fracking a hydrocarbon formation at a plurality of clustered contiguous locations along a wellbore within said formation and installing sand screens within a tubular

liner within said wellbore at each of said plurality of locations to prevent ingress of sand into the tubular liner at each of said locations, said method comprising the steps of:

(i) locating a tubular liner having:

-a hollow interior bore;

- a plurality of contiguous frac ports spaced along a periphery of said tubular liner;

- a corresponding plurality of sliding sleeve members respectively initially covering each of said frac ports;

within said wellbore;

(ii) situating an actuation member having a radially and resiliently outwardly-biased protuberance of a first profile within said tubular liner, said radially-outwardly biased protuberance having a chamfer on a downhole side thereof;

(iii) applying a pressurized fluid to an uphole end of said actuation member and causing said actuation member to flow downhole and to a position in said tubular liner where said profile thereon engages a corresponding mating profile on a first of said sliding sleeve members;

(iv) continuing to apply said pressurized fluid to said tubular liner and causing said first sliding sleeve member to move further downhole and simultaneously thereby uncover and thereby open a first associated frac port in said tubular liner and allow fluid communication from said interior bore to an exterior of said tubular liner and said hydrocarbon formation via the first opened frac port;

(v) continuing to apply said pressurized fluid to said tubular liner and causing said resiliently-based protuberance, due to said chamfer on a downhole side edge thereof, to become radially inwardly depressed and thereby disengage said profile from said mating engagement with said mating profile on said first sliding sleeve member and thereby permit said actuation member to then further move downhole

and said resiliently-biased protuberance thereon to then engage a further corresponding mating profile on a second sliding sleeve member downhole from said first sliding sleeve member;

5 **(vi)** continuing to apply said pressurized fluid to said tubular liner and causing said second sliding sleeve member to move further downhole and simultaneously thereby uncover and thereby open a further second frac port in said tubular liner and allow fluid communication from said interior bore to an exterior of said tubular liner and said hydrocarbon formation via the further opened second frac port;

10 **(vii)** injecting a fracking fluid into said tubular liner and causing said frac fluid to flow into the hydrocarbon formation via the opened first and second frac ports;

15 **(viii)** situating a first sand screen sub within said tubular liner, said first sand screen sub having a resiliently-outwardly biased protuberance having a profile, and said first sand screen sub further having an annular screen mesh about an outer periphery thereof;

20 **(ix)** applying a pressurized fluid to an uphole end of said first sand screen sub and causing said first sand screen sub to flow downhole to a position in said tubular liner where said annular screen mesh thereof underlies said second open frac port and causing said profile of said protuberance thereon to engage a mating profile on an interior of said tubular liner and thereby retain said first sand screen sub and said annular screen mesh thereof underlying said second open frac port;

25 **(x)** situating a second sand screen sub within said tubular liner, said second sand screen sub having a resiliently-outwardly biased protuberance having a profile different than the profile of the protuberance on said first sand screen sub, and likewise having an annular screen mesh about an outer periphery thereof;

(xi) applying a pressurized fluid to an uphole end of said second sand screen sub and causing said second sand screen sub to flow downhole to a position in said tubular liner where said annular screen mesh thereof underlies said first open frac port, and causing said profile of said protuberance thereon to engage a mating profile on an interior of said tubular liner and thereby retain said second sand screen sub and said annular screen mesh thereof underlying said first open frac port.

5

10 **25.** The method as claimed in claim **24**, further comprising the step after step **(iv)**, **(vi)** or **(vii)** of injecting pressurized fluid into said interior bore at a pressure sufficient to rupture a burst disk member located on said actuation member so as to thereafter allow fluid to flow through said actuation member.

15 **26.** The method as claimed in claim **24**, further comprising the step after step **(vii)** of injecting pressurized fluid into said interior bore at a pressure sufficient to rupture a burst disk member located on said sand screen member, so as to thereafter allow fluid to flow through said sand screen member .

27. The method as claimed in claim **24**, further comprising the step after step **(vii)** of exposing said actuation member to a corrosive fluid so as to dissolve a portion of said actuation member so as to thereafter allow fluid to flow through said actuation member.

20

28. The method as claimed in claim **24**, further comprising the step sometime after step **(vi)** of exposing said actuation member to a corrosive fluid so as to dissolve all or substantially all of said actuation member.

29. The method as claimed in claim 24, further comprising the step after step (viii) of exposing said first sand screen sub to a corrosive fluid so as to dissolve a portion of said first sand screen sub so as to thereafter allow fluid to flow longitudinally through said first sand screen sub.

5 30. The method as claimed in claim 24, further comprising the step after step (x) of exposing said second sand screen sub to a corrosive fluid so as to dissolve a portion of said second sand screen sub so as to thereafter allow fluid to flow longitudinally through said second sand screen sub.

10 31. The method as claimed in claim 24, further comprising the step, after step (iv) and step (vi) of allowing a biased protuberance on said sliding sleeve member to, when the first and second sliding sleeve member have respectively uncovered a respective frac port, to engage a mating groove in said tubular member so as to retain, respectively, said first and second sliding sleeve member in a position where a respective associated frac port is uncovered.

15 32. A method for successively uncovering spaced-apart frac ports situated along a hollow tubular liner, carrying out a fracking operation at each uncovered frac port, and installing a sand screen at each of said uncovered frac ports, comprising the steps of:

20 (i) locating an actuation member having a resiliently outwardly biased collet finger of a given profile thereon in said tubular liner, said tubular liner initially having a plurality of sliding sleeve members respectively covering a corresponding plurality of said spaced-apart frac ports along said tubular liner;

25 (ii) flowing said actuation member downhole so as to cause said profile on said first actuation member to engage an interior circumferential groove on a sliding sleeve member covering an lowermost covered frac port along said tubular liner, wherein said interior circumferential groove profile corresponds to said profile on said collet finger, and injecting

fluid into said tubular liner and causing said actuation member and said lowermost sliding sleeve member to together move downhole and thereby uncover an associated of said ports in said tubular liner and causing a resiliently-biased protuberance on said lowermost sliding sleeve member to then engage an aperture in said tubular liner so as to cause said lowermost sliding sleeve member to thereafter remain immovable within said tubular liner;

5

(iii) injecting a pressurized frac fluid into said tubular liner to frac the formation at the location of the opened frac port;

(iv) injecting or allowing fluid in said tubular liner to dissolve a plug in said actuation member, or alternatively applying pressurized fluid in said tubular liner to burst a plug or disk in said actuation member, so as to thereafter allow longitudinal flow of fluid through said actuation member;

10

(v) injecting a sand screen sub down said tubular liner, said sand screen sub having a resiliently-outwardly biased protruding member thereon, which sand screen sub upon reaching said first actuation member then underlies said opened port and said protruding member thereafter prevents said sand screen sub from moving back uphole ; and

15

(vi) repeating steps (i)-(v) until all of said plurality of spaced-apart ports along said tubular liner have been uncovered, the wellbore fracked at each opened frac port, and sand screen subs installed at each opened frac port.

20

AMENDED CLAIMS

received by the International Bureau on 05 April 2018 (05.04.2018)

1. A system for fracking a hydrocarbon formation at a given location along a wellbore and subsequently allowing installation of a sand screen at said location without having to “trip out” a frac string prior to commencing production, comprising;

- a tubular liner insertable within said wellbore and having an interior bore, further comprising:

(a) a plurality of spaced-apart frac ports longitudinally spaced at intervals along said tubular liner, providing, when open, fluid communication between the interior bore of the tubular liner and an exterior of the tubular liner;

(b) a corresponding plurality of cylindrical hollow sliding sleeve members, each configured in an initial closed position to cover a corresponding of said frac ports and prevent flow of fluid from the interior bore to an exterior of the tubular liner, and slidably moveable longitudinally in the interior bore to an open position to uncover said corresponding of the frac ports, each of the plurality of sliding sleeve member members initially covering a respective of said plurality of frac ports so as to prevent flow of a fluid from within the interior bore to the exterior of the tubular liner, each of the plurality of cylindrical hollow sliding sleeve members having an interior circumferential groove profile therein of a given longitudinal width; and

(c) a plurality of shear members, initially securing respectively said slidable plurality of sliding sleeve members to the tubular liner in the initial closed position thereof, and sheareable when a longitudinal force is applied thereto to thereafter allow longitudinal slidable movement of respective of said slidable plurality of sliding sleeve members;

at least one actuation member, insertable within the interior bore of the tubular liner, comprising:

(a) a cylindrical hollow collet sleeve, having a radially-outwardly biased protuberance on a periphery thereof having a first profile, said radially-outwardly biased

protuberance configured to matingly engage said interior circumferential groove profile on at least one of the plurality of sliding sleeve members;

(b) a burst plate, a dissolvable plug member, or a seating surface wherein the seating surface is configured to provide a sealing surface against which a dissolvable plug member may abut, which wherein the burst plate, the dissolvable plug member, or the seating sealing surface in combination with said plug the dissolvable member, at least for a limited time prevents pressurized fluid injected downhole in said interior bore from travelling past said actuation member in said tubular liner thereby allowing said actuation member to be flowed downhole by said pressurized fluid; and

at least one cylindrical sand screen sub, insertable within the interior bore of said tubular liner and displaceable within said tubular liner to a location therein proximate a one of said frac ports in said tubular liner whose corresponding sliding sleeve member has been uncovered by said actuation member, said at least one sand screen sub comprising:

(a) a cylindrical hollow member having at an uphole end thereof a dissolvable plug member or burst plate which at least for a limited time substantially obstructs passage of fluid within said interior bore thereby causing pressurized fluid injected downhole in said bore of said tubular liner to force said sand screen sub downhole in said tubular liner;

(b) a cylindrical, longitudinally-extending oil-permeable screen mesh forming a portion of an outer periphery of said sand screen sub downhole from said dissolvable plug member or burst plate thereon, which screen mesh when said sand screen sub is located proximate said one of said frac ports, underlies said one of said frac ports and prevents ingress of sand but permits ingress of oil, from said formation into the interior bore via said one of said frac ports; and

(c) a resiliently outwardly biased retaining member, which engages, directly or indirectly, said tubular liner when said sand screen sub has flowed down said tubular liner to said one of said frac ports whose corresponding sliding sleeve member has been opened and to a position within the tubular liner wherein the screen mesh of said sand screen sub underlies said one of said frac ports, which retaining member after

engagement with said tubular liner prevents uphole displacement of said sand screen sub in said tubular liner.

2. The system for fracking a hydrocarbon formation as claimed in claim 1, which ensures that the sand screen sub may flow downhole to a position underlying a desired opened frac port:

wherein said resiliently outwardly biased retaining member on said at least one sand screen sub has a chamfer on a downhole side edge thereof and a flat face on an uphole side edge thereof perpendicularly disposed to a longitudinal axis of said tubular liner; and

wherein downhole movement of said at least one sand screen sub in said tubular liner is allowed by said chamfer causing said resiliently outwardly biased retaining member to become radially depressed upon fluid pressure being exerted on an uphole side of said sand screen sub; and

wherein uphole movement of said sand screen sub is prevented, when said screen mesh of said sand screen sub underlies said one of said frac ports, by said flat face engaging, directly or indirectly, an annular region in said tubular liner.

3. The system for fracking a hydrocarbon formation as claimed in claim 1, wherein each of said sliding sleeve members, and said tubular liner at a location proximate each of said frac ports, have mating engagement means which become respectively lockingly engaged when said sliding sleeve members are each respectively moved so as to uncover a corresponding frac port, which mating engagement means retains said sliding sleeve members, once in said open position, from thereafter returning to a closed position covering said corresponding frac port.

4. The system for fracking a hydrocarbon formation as claimed in claim 3, wherein the mating engagement means on said sliding sleeve members comprises a plurality of collet fingers, radially outwardly biased, and extending from a downhole end of each sliding sleeve member, and said mating engagement means on said tubular liner comprises an annular circumferential ring on said tubular liner, which when one of said slidable sleeve members

travels to said open position, said collet fingers thereof matingly engage said annular circumferential ring on said sliding sleeve member.

5. The system for fracking a hydrocarbon formation as claimed in claim 1, wherein:

-said profile of said radially-outwardly biased protuberance on said actuation member comprises a raised collet profile of a width W_2 ; and

-said interior circumferential groove profile of given longitudinal width on said one sliding sleeve member is a mating circumferential groove of a width equal to or greater than W_2 .

6. A system for fracking a hydrocarbon formation as claimed in claim 5, further comprising:

a second actuation member, insertable within the interior bore of the tubular liner, comprising:

(a) a cylindrical hollow collet sleeve, having a radially-outwardly biased protuberance on a periphery thereof having a second profile of width W_1 , where $W_1 < W_2$, said radially-outwardly biased protuberance configured to matingly engage said interior circumferential groove profile on another of the plurality of sliding sleeve members, having a width equal to or greater than W_1 but less than W_2 ;

(b) a burst plate, a dissolvable plug member, or a seating surface wherein the seating surface is situated at an uphole end of said collet sleeve and is configured to provide a sealing surface against which a dissolvable plug member may abut, which wherein the burst plate, the dissolvable plug member, or plug the dissolvable member and the seating surface are situated at an uphole end of said collet sleeve and at least for a limited time prevent pressurized fluid injected downhole in said interior bore from travelling past said actuation member in said tubular liner;

a second sand screen sub, insertable within the interior bore of said tubular liner comprising:

(a) a cylindrical hollow member having at an uphole end thereof a dissolvable plug member or burst plate which at least for a limited time substantially obstructs passage of fluid within said interior bore thereby causing pressurized fluid injected downhole

in said bore of said tubular liner to force said sand screen sub downhole in said tubular liner ;

(b) a cylindrical, longitudinally-extending oil-permeable screen mesh forming a portion of an outer periphery of said second sand screen sub downhole from said dissolvable plug member or burst plate thereon, which screen mesh when said sand screen sub is located proximate said one of said frac ports, underlies said one of said frac ports and prevents ingress of sand but permits ingress of oil, from said formation into the interior bore via said one of said frac ports; and

(c) a retaining member on said cylindrical hollow member, which engages, directly or indirectly, said tubular liner when said second sand screen sub has flowed down said tubular liner to another of said frac ports whose corresponding sliding sleeve member has been opened on said tubular liner by said second actuation member to a position wherein the screen mesh of said sand screen sub underlies said another of said frac ports, which retaining member after engagement with said tubular liner prevents uphole displacement of said second sand screen sub in said tubular liner.

7. The system for fracking a hydrocarbon formation as claimed in claim 1, wherein:

said radially-outwardly biased protuberance on said actuation member is configured such that after matingly engaging said interior circumferential groove profile on at least one of the plurality of sliding sleeve members, such radially-outwardly biased protuberance on said actuation member remains lockingly engaged with said interior circumferential groove profile on said at least one sliding sleeve member and said actuation member is thereby prevented from further downhole movement within said tubular liner.

8. The system for fracking a hydrocarbon formation as claimed in claim 7, wherein after said actuation member has moved a most downhole of said sliding sleeves to an open position uncovering said corresponding frac port, and said sand screen sub flowed downhole to underlie the uncovered frac port, further movement of said at least one sand screen sub downhole in said tubing liner is prevented by said sand screen sub abutting said actuation member.

9. The system for fracking a hydrocarbon formation as claimed in claim 1 at a plurality of contiguous locations along a wellbore, wherein:

said radially outwardly-biased protuberance on said actuation member releasibly lockingly engages said interior circumferential groove profile on said one of said sliding sleeve members to allow subsequent downhole movement within said tubular liner.

10. The system for fracking a hydrocarbon formation as claimed in claim 9, wherein:

said radially-outwardly biased protuberance on said actuation member has a chamfer on a downhole side thereof; and

wherein upon said radially-outwardly biased protuberance engaging said interior circumferential groove profile in said at least one sliding sleeve member and said at least one sliding sleeve member being moved downhole to open said desired frac port, and upon continued further fluid pressure applied to an uphole side of said actuation member, said chamfer engages a downhole side edge of the circumferential groove profile and said radially-outwardly biased protuberance thereafter becomes disengaged from mating engagement with said interior circumferential groove thereby allowing said actuation member to continue moving downhole to successively engage one or more additional sliding sleeve members and uncover at least one additional corresponding frac port.

11. The system for fracking a hydrocarbon formation as claimed in claim 10, wherein the at least one sand screen sub comprises a plurality of sand screen subs, and wherein:

the retaining member on each sand screen sub possesses a unique profile or width; and

the tubular liner, proximate each frac port, possesses an annular region of a corresponding unique profile or width;

wherein the retaining member on one of said sand screen subs, when said one of said sand screen subs is flowed down the tubular liner, will only engage the tubular liner at a particular annular region along said tubing liner, and the retaining member thereof after engagement with said annular region prevents longitudinal displacement of said sand screen sub from said position in said tubular liner.

12. The system for fracking a hydrocarbon formation as claimed in claim 1, wherein said at least one sand screen sub comprises a plurality of sand screen subs, and wherein:

said retaining member on each sand screen sub is of a unique width relative to a width of a retaining member on another of said sand screen subs; and

wherein a retaining member of width "X2" on a first sand screen sub inserted downhole is of a greater width than a width X1 of a retaining member on a second sand screen sub thereafter subsequently inserted downhole in said tubular liner; and

said retaining member on said first sand screen sub matingly engages a corresponding annular region in said tubular liner of an equal or greater width X2; and

said retaining member on said second sand screen sub matingly engages a corresponding annular region of width $>X1$ but $< X2$, located uphole in said tubular liner.

13. The system for fracking a hydrocarbon formation as claimed in claim 7, 8, or 9 wherein said actuation member is dissolvable upon a corrosive fluid being applied to said interior bore of said tubular liner.

14. A method for conducting a fracking procedure at least one location along a wellbore situated within a hydrocarbon formation, and thereafter installing a sand screen within a tubular liner within said wellbore to prevent ingress of sand into said tubular liner, comprising the steps of:

(i) locating a tubular liner having:

-a hollow interior bore;

- a plurality of frac ports spaced along a periphery of said tubular liner;

- a corresponding plurality of sliding sleeve members respectively initially covering each of said frac ports;

within said wellbore;

(ii) situating a first actuation member having a resiliently outwardly biased protuberance of a first profile, within said tubular liner;

(iii) applying a pressurized fluid to an uphole end of said first actuation member and causing said first actuation member to flow downhole and to a position in said tubular liner where said radially outwardly-biased protuberance thereon engages a mating profile on one of said plurality of sliding sleeve members;

(iv) continuing to apply said pressurized fluid to said tubular liner and causing said one sliding sleeve member and actuation member to together move downhole and uncover and thereby open an associated one of said frac ports in said tubular liner and thereby allow fluid communication from said interior bore to an exterior of said tubular liner and said hydrocarbon formation via the opened associated frac port;

(v) injecting a fracking fluid into said tubular liner and causing said frac fluid to flow into the hydrocarbon formation via the opened frac port;

(vi) inserting a first sand screen sub into said tubular liner, said first sand screen sub having:

- a resiliently-outwardly biased protuberance having a given profile; and

- an annular screen mesh about an outer periphery of said first sand screen sub;

and

(vii) applying a pressurized fluid to an uphole end of said first sand screen sub and causing said first sand screen sub to flow downhole to a position in said tubular liner where said annular screen mesh thereof underlies said open frac port and causing said profile of said resiliently-outwardly biased protuberance thereon to engage a mating profile on an interior of said tubular liner and thereby retain said first sand screen sub in a position wherein the annular screen mesh thereof underlies said open frac port.

15. The method as claimed in claim 14, further comprising the step, after step (iv) or step (v), of injecting pressurized fluid into said interior bore at a pressure sufficient to rupture a

burst disk member located on said actuation member, so as to thereafter allow fluid to flow through said actuation member.

16. The method as claimed in claim 14, further comprising the step after step (vii) of injecting pressurized fluid into said interior bore at a pressure sufficient to rupture a burst disk member located on said sand screen member, so as to thereafter allow fluid to flow through said sand screen member .

17. The method as claimed in claim 14, further comprising the step at some time after step (iv) of dissolving a plug member in said actuation member to allow subsequent flow of fluid through said actuation member after said actuation member has moved said sliding sleeve downhole and thereby opened said associated frac port.

18. The method as claimed in claim 17, wherein said step of dissolving said plug member further comprises flowing a corrosive fluid down said tubular liner to said actuation member.

19. The method as claimed in claim 14, further comprising the step after step (vii) of exposing said sand screen sub to a corrosive fluid so as to dissolve a portion of said sand screen sub so as to thereafter allow fluid to flow longitudinally through said sand screen sub.

20. The method as claimed in claim 14, further comprising the step at some time after step (iv) of flowing a corrosive fluid into said interior bore and causing said actuation member to dissolve.

21. The method as claimed in claim 14, wherein when said first actuation member engages said one sliding sleeve member and moves said sliding sleeve member to said open position, causing said actuation member to lockingly engage said sliding sleeve member, and said sliding sleeve member to further lockingly engage said tubing liner, thereby preventing further movement of said actuation member within said tubing liner.

22. The method as claimed in claim 14 for further conducting a fracking procedure at a plurality of spaced apart locations along said wellbore and installing sand screens within the tubular liner at each of said plurality of locations to prevent ingress of sand into the tubular

liner at each of said locations, wherein after step (vii) such method further comprises carrying out the following further steps:

(viii) situating a second actuation member having a resiliently-outwardly biased protuberance of a second profile thereon different than said first profile, within said tubular liner;

(ix) applying a pressurized fluid to an uphole end of said second actuation member and causing said second actuation member to flow downhole and to a position in said tubular liner where said second profile on said second actuation member engages a corresponding mating profile on a further one of said sliding sleeve members;

(x) continuing to apply said pressurized fluid to said tubular liner and causing said second actuation member and said further one of sliding sleeve member to together move downhole and uncover and thereby open a further associated of said frac ports in said tubular liner and thereby allow fluid communication from said interior bore to an exterior of said tubular liner and said hydrocarbon formation via the further opened frac port;

(xi) injecting a fracking fluid into said tubular liner and causing said frac fluid to flow into the hydrocarbon formation via the further opened frac port;

(xii) situating a second sand screen sub within said tubular liner, said second sand screen sub having a resiliently-outwardly biased protuberance thereon and an annular screen mesh about an outer periphery thereof; and

(xiii) applying a pressurized fluid to an uphole end of said second sand screen sub and causing said second sand screen sub to flow downhole to a position in said tubular liner where said screen mesh thereon underlies said further opened frac port, and causing said resiliently-outwardly biased protuberance on said second sand screen sub to engage a mating profile on an interior of said tubular liner proximate said further opened frac port so as to thereby retain said second sand screen sub and said annular screen mesh thereof underlying said further opened frac port .

23. The method as claimed in claim 22, wherein said resiliently-outwardly biased protuberance of said first actuation member is of a width W_2 , and said resiliently-outwardly biased protuberance of said second actuation member is of a width W_1 , wherein $W_1 < W_2$.

24. A method for fracking a hydrocarbon formation at a plurality of clustered contiguous locations along a wellbore within said formation and installing sand screens within a tubular liner within said wellbore at each of said plurality of locations to prevent ingress of sand into the tubular liner at each of said locations, said method comprising the steps of:

(i) locating a tubular liner having:

- a hollow interior bore;

- a plurality of contiguous frac ports spaced along a periphery of said tubular liner;

- a corresponding plurality of sliding sleeve members respectively initially covering each of said frac ports;

within said wellbore;

(ii) situating an actuation member having a radially and resiliently outwardly-biased protuberance of a first profile within said tubular liner, said radially-outwardly biased protuberance having a chamfer on a downhole side thereof;

(iii) applying a pressurized fluid to an uphole end of said actuation member and causing said actuation member to flow downhole and to a position in said tubular liner where said profile thereon engages a corresponding mating profile on a first of said sliding sleeve members;

(iv) continuing to apply said pressurized fluid to said tubular liner and causing said first sliding sleeve member to move further downhole and simultaneously thereby uncover and thereby open a first associated frac port in said tubular liner and allow fluid communication from said interior bore to an exterior of said tubular liner and said hydrocarbon formation via the first opened frac port;

(v) continuing to apply said pressurized fluid to said tubular liner and causing said resiliently-biased protuberance, due to said chamfer on a downhole side edge thereof, to become radially inwardly depressed and thereby disengage said profile from said mating engagement with said mating profile on said first sliding sleeve member and thereby permit said actuation member to then further move downhole and said resiliently-biased protuberance thereon to then engage a further corresponding mating profile on a second sliding sleeve member downhole from said first sliding sleeve member;

(vi) continuing to apply said pressurized fluid to said tubular liner and causing said second sliding sleeve member to move further downhole and simultaneously thereby uncover and thereby open a further second frac port in said tubular liner and allow fluid communication from said interior bore to an exterior of said tubular liner and said hydrocarbon formation via the further opened second frac port;

(vii) injecting a fracking fluid into said tubular liner and causing said frac fluid to flow into the hydrocarbon formation via the opened first and second frac ports;

(viii) situating a first sand screen sub within said tubular liner, said first sand screen sub having a resiliently-outwardly biased protuberance having a profile, and said first sand screen sub further having an annular screen mesh about an outer periphery thereof;

(ix) applying a pressurized fluid to an uphole end of said first sand screen sub and causing said first sand screen sub to flow downhole to a position in said tubular liner where said annular screen mesh thereof underlies said second open frac port and causing said profile of said protuberance thereon to engage a mating profile on an interior of said tubular liner and thereby retain said first sand screen sub and said annular screen mesh thereof underlying said second open frac port;

(x) situating a second sand screen sub within said tubular liner, said second sand screen sub having a resiliently-outwardly biased protuberance having a profile different than the profile of the protuberance on said first sand screen sub, and likewise having an annular screen mesh about an outer periphery thereof;

(xi) applying a pressurized fluid to an uphole end of said second sand screen sub and causing said second sand screen sub to flow downhole to a position in said tubular liner where said annular screen mesh thereof underlies said first open frac port, and causing said profile of said protuberance thereon to engage a mating profile on an interior of said tubular liner and thereby retain said second sand screen sub and said annular screen mesh thereof underlying said first open frac port.

25. The method as claimed in claim 24, further comprising the step after step (iv), (vi) or (vii) of injecting pressurized fluid into said interior bore at a pressure sufficient to rupture a burst disk member located on said actuation member so as to thereafter allow fluid to flow through said actuation member.

26. The method as claimed in claim 24, further comprising the step after step (vii) of injecting pressurized fluid into said interior bore at a pressure sufficient to rupture a burst disk member located on said sand screen member, so as to thereafter allow fluid to flow through said sand screen member.

27. The method as claimed in claim 24, further comprising the step after step (vii) of exposing said actuation member to a corrosive fluid so as to dissolve a portion of said actuation member so as to thereafter allow fluid to flow through said actuation member.

28. The method as claimed in claim 24, further comprising the step sometime after step (vi) of exposing said actuation member to a corrosive fluid so as to dissolve all or substantially all of said actuation member.

29. The method as claimed in claim 24, further comprising the step after step (viii) of exposing said first sand screen sub to a corrosive fluid so as to dissolve a portion of said first sand screen sub so as to thereafter allow fluid to flow longitudinally through said first sand screen sub.

30. The method as claimed in claim 24, further comprising the step after step (x) of exposing said second sand screen sub to a corrosive fluid so as to dissolve a portion of said second sand screen sub so as to thereafter allow fluid to flow longitudinally through said second sand screen sub.

31. The method as claimed in claim 24, further comprising the step, after step (iv) and step (vi) of allowing a biased protuberance on said sliding sleeve member to, when the first and second sliding sleeve member have respectively uncovered a respective frac port, to engage a mating groove in said tubular member so as to retain, respectively, said first and second sliding sleeve member in a position where a respective associated frac port is uncovered.

32. A method for successively uncovering spaced-apart frac ports situated along a hollow tubular liner, carrying out a fracking operation at each uncovered frac port, and installing a sand screen at each of said uncovered frac ports, comprising the steps of:

(i) locating an actuation member having a resiliently outwardly biased collet finger of a given profile thereon in said tubular liner, said tubular liner initially having a plurality of sliding sleeve members respectively covering a corresponding plurality of said spaced-apart frac ports along said tubular liner;

(ii) flowing said actuation member downhole so as to cause said profile on said first actuation member to engage an interior circumferential groove on a sliding sleeve member covering an lowermost covered frac port along said tubular liner, wherein said interior circumferential groove profile corresponds to said profile on said collet finger, and injecting fluid into said tubular liner and causing said actuation member and said lowermost sliding sleeve member to together move downhole and thereby uncover an associated of said ports in said tubular liner and causing a resiliently-biased protuberance on said lowermost sliding sleeve member to then engage an aperture in said tubular liner so as to cause said lowermost sliding sleeve member to thereafter remain immovable within said tubular liner;

(iii) injecting a pressurized frac fluid into said tubular liner to frac the formation at the location of the opened frac port;

(iv) injecting or allowing fluid in said tubular liner to dissolve a plug in said actuation member, or alternatively applying pressurized fluid in said tubular liner to burst a plug or disk in said actuation member, so as to thereafter allow longitudinal flow of fluid through said actuation member;

(v) injecting a sand screen sub down said tubular liner, said sand screen sub having a resiliently-outwardly biased protruding member thereon, which sand screen sub upon reaching said first actuation member then underlies said opened port and said protruding member thereafter prevents said sand screen sub from moving back uphole; and

(vi) repeating steps (i)-(v) until all of said plurality of spaced-apart ports along said tubular liner have been uncovered, the wellbore fracked at each opened frac port, and sand screen subs installed at each opened frac port.

33. A system for fracking a hydrocarbon formation at a given location along a wellbore and subsequently allowing installation of a sand screen at said location without having to “trip out” a frac string prior to commencing production, comprising;

- a tubular liner insertable within said wellbore and having an interior bore, further comprising:

(a) a plurality of spaced-apart frac ports longitudinally spaced at intervals along said tubular liner, providing, when open, fluid communication between the interior bore of the tubular liner and an exterior of the tubular liner;

(b) a corresponding plurality of cylindrical hollow sliding sleeve members, each configured in an initial closed position to cover a corresponding set of said frac ports and prevent flow of fluid from the interior bore to an exterior of the tubular liner, and slidably moveable longitudinally in the interior bore to an open position to uncover said corresponding set of the frac ports; and

(c) a plurality of shear members, initially securing respectively said plurality of sliding sleeve members to the tubular liner in the initial closed position thereof, and sheareable when a longitudinal force is applied thereto to thereafter allow longitudinal slidable movement of respective one of said plurality of sliding sleeve members;

- at least one actuation member, insertable within the interior bore of the tubular liner and engagable with at least one of the plurality of sliding sleeve members for shearing the shear members that initially secure the at least one sliding sleeve member and conditioning the at least one sliding sleeve member to the open position;

- at least one cylindrical sand screen sub, insertable within the interior bore of said tubular liner and displaceable within said tubular liner to a location therein proximate one of said frac ports in said tubular liner whose corresponding sliding sleeve member has been uncovered to the open position by said actuation member, said at least one sand screen sub comprising:

(a) a cylindrical hollow member having at an uphole end thereof a dissolvable plug member or burst plate which at least for a limited time substantially obstructs passage of fluid within said interior bore thereby causing pressurized fluid injected downhole in said bore of said tubular liner to force said sand screen sub downhole in said tubular liner; and

(b) a cylindrical, longitudinally-extending oil-permeable screen mesh forming a portion of an outer periphery of said sand screen sub downhole from said dissolvable plug member or burst plate thereon, which screen mesh when said sand screen sub is located proximate said one of said frac ports, underlies said one of said frac ports and prevents ingress of sand but permits ingress of oil, from said formation into the interior bore via said one of said frac ports.

34. The system for fracking a hydrocarbon formation as claimed in claim 33, wherein said at least one sand screen sub further comprises:

(c) a resiliently outwardly biased retaining member directly or indirectly engagable with a mating profile on said tubular liner when said sand screen sub has flowed down said tubular liner to said one of said frac ports whose corresponding sliding sleeve member has been opened and to a position within the tubular liner wherein the screen mesh of said sand screen sub underlies said one of said frac ports, which retaining member after engagement with said

tubular liner prevents uphole displacement of said sand screen sub in said tubular liner.

35. The system for fracking a hydrocarbon formation as claimed in claim 33, wherein said at least one sand screen sub is flowable downhole to a position underlying a desired opened frac port.

36. The system for fracking a hydrocarbon formation as claimed in claim 34, wherein said resiliently outwardly biased retaining member on said at least one sand screen sub has a chamfer on a downhole side edge thereof and a flat face on an uphole side edge thereof perpendicularly disposed to a longitudinal axis of said tubular liner; and

wherein downhole movement of said at least one sand screen sub in said tubular liner is allowed by said chamfer causing said resiliently outwardly biased retaining member to become radially depressed upon fluid pressure being exerted on an uphole side of said sand screen sub; and

wherein uphole movement in said sand screen sub is prevented, when said screen mesh of said sand screen sub underlies said one of said frac ports, by said flat face engaging, directly or indirectly, an annular region in said tubular liner.

37. A system for fracking a hydrocarbon formation as claimed in claim 34, further comprising:

- a second sand screen sub, insertable within the interior bore of said tubular liner comprising:

(a) a cylindrical hollow member having at an uphole end thereof a dissolvable plug member or burst plate which at least for a limited time substantially obstructs passage of fluid within said interior bore thereby causing pressurized fluid injected downhole in said bore of said tubular liner to force said sand screen sub downhole in said tubular liner;

(b) a cylindrical, longitudinally-extending oil-permeable screen mesh forming a portion of an outer periphery of said second sand screen sub downhole from

said dissolvable plug member or burst plate thereon, which screen mesh when said sand screen sub is located proximate said one of said frac ports, underlies said one of said frac ports and prevents ingress of sand but permits ingress of oil, from said formation into the interior bore via said one of said frac ports; and

(c) a retaining member on said cylindrical hollow member, which engages, directly or indirectly, said tubular liner when said second sand screen sub has flowed down said tubular liner to another of said frac ports whose corresponding sliding sleeve member has been opened on said tubular liner by ~~said a~~ second actuation member to a position wherein the screen mesh of said sand screen sub underlies said another of said frac ports, which retaining member after engagement with said tubular liner prevents uphole displacement of said second sand screen sub in said tubular liner.

38. The system for fracking a hydrocarbon formation as claimed in claim 33, wherein after said actuation member has moved a most downhole of said sliding sleeves to an open position uncovering said corresponding frac port, and said sand screen sub flowed downhole to underlie the uncovered frac port, further movement of said at least one sand screen sub downhole in said tubing liner is prevented by said sand screen sub abutting said actuation member.

39. The system for fracking a hydrocarbon formation as claimed in claim 34, wherein the at least one sand screen sub comprises a plurality of sand screen subs, and wherein:

the retaining member on each sand screen sub possesses a unique profile or width; and

the tubular liner, proximate each frac port, possesses an annular region of a corresponding unique profile or width;

wherein the retaining member on one of said sand screen subs, when said one of said sand screen subs is flowed down the tubular liner, will only engage the tubular liner at a particular annular region along said tubing liner, and the retaining member thereof after engagement with said annular region prevents longitudinal displacement of said sand screen sub from said position in said tubular liner.

40. The system for fracking a hydrocarbon formation as claimed in claim 34, wherein said at least one sand screen sub comprises a plurality of sand screen subs, and wherein:

said retaining member on each sand screen sub is of a unique width relative to a width of a retaining member on another of said sand screen subs; and

wherein a retaining member of width " X_2 " on a first sand screen sub inserted downhole is of a greater width than a width X_1 of a retaining member on a second sand screen sub thereafter subsequently inserted downhole in said tubular liner; and

said retaining member on said first sand screen sub matingly engages a corresponding annular region in said tubular liner of an equal or greater width X_2 ; and

said retaining member on said second sand screen sub matingly engages a corresponding annular region of width $>X_1$ but $< X_2$, located uphole in said tubular liner .

41. The system for fracking a hydrocarbon formation as claimed in claim 33 or 38 wherein said actuation member is dissolvable upon a corrosive fluid being applied to said interior bore of said tubular liner.

42. A method for conducting a fracking procedure at least one location along a wellbore situated within a hydrocarbon formation, and thereafter installing a sand screen within a tubular liner within said wellbore to prevent ingress of sand into said tubular liner, comprising the steps of:

(i) locating a tubular liner having:

- a hollow interior bore;
- a plurality of frac ports spaced along a periphery of said tubular liner;
- a corresponding plurality of sliding sleeve members respectively initially covering each of said frac ports;

within said wellbore;

(ii) situating a first actuation member within said tubular liner to engage the first actuation member with a first one of the plurality of sliding sleeve members, said first sliding sleeve member associated with a first set of said frac ports;

(iii) actuating said first actuation member to actuate the first sliding sleeve member to uncover and thereby open the associated first set of frac ports in said tubular liner and thereby allow fluid communication from said interior bore to an exterior of said tubular liner and said hydrocarbon formation via the opened first set of frac ports;

(iv) injecting a fracking fluid into said tubular liner and causing said frac fluid to flow into the hydrocarbon formation via the opened first set of frac ports;

(v) inserting a first sand screen sub into said tubular liner, said first sand screen sub having:

- a resiliently-outwardly biased protuberance having a given profile;
- and
- an annular screen mesh about an outer periphery of said first sand screen sub; and

(vi) applying a pressurized fluid to an uphole end of said first sand screen sub and causing said first sand screen sub to flow downhole to a position in said tubular liner where said annular screen mesh thereof underlies said open frac port and causing said profile of said resiliently-outwardly biased protuberance thereon to engage a mating profile on an interior of said tubular liner and thereby retain said first sand screen sub in a position wherein the annular screen mesh thereof underlies said open frac port.

43. The method as claimed in claim 42, further comprising the step after step (vi), of injecting pressurized fluid into said interior bore at a pressure sufficient to rupture a burst disk member

located on said sand screen sub, so as to thereafter allow fluid to flow through said sand screen sub.

44. The method as claimed in claim 42, further comprising the step, at some time after step (iii), of dissolving a plug member in said first actuation member to allow subsequent flow of fluid through said first actuation member after said first actuation member has moved said first sliding sleeve downhole and thereby opened said associated first set of frac ports.

45. The method as claimed in claim 44, wherein said step of dissolving said plug member further comprises flowing a corrosive fluid down said tubular liner to said first actuation member.

46. The method as claimed in claim 42, further comprising the step, after step (vi) of exposing said sand screen sub to a corrosive fluid so as to dissolve a portion of said sand screen sub so as to thereafter allow fluid to flow longitudinally through said sand screen sub.

47. The method as claimed in claim 42, further comprising the step, at some time after step (iii) of flowing a corrosive fluid into said interior bore and causing said actuation member to dissolve.

48. The method as claimed in claim 42 for further conducting a fracking procedure at a plurality of spaced apart locations along said wellbore and installing sand screens within the tubular liner at each of said plurality of locations to prevent ingress of sand into the tubular liner at each of said locations, wherein after step (vi) such method further comprises carrying out the following further steps:

(vii) situating a second actuation member within said tubular liner to engage the first actuation member with a second one of the plurality of sliding sleeve members, said sliding sleeve member associated with a second set of said frac ports

(viii) actuating said second actuation member to actuate the sliding sleeve member to uncover and thereby open the associated second set of frac ports in said tubular liner and thereby allow fluid communication from said interior bore to an exterior of said tubular liner and said hydrocarbon formation via the opened associated frac port;

(ix) injecting a fracking fluid into said tubular liner and causing said frac fluid to flow into the hydrocarbon formation via the opened second set of frac ports;

(x) situating a second sand screen sub within said tubular liner, said second sand screen sub having a resiliently-outwardly biased protuberance thereon and an annular screen mesh about an outer periphery thereof; and

(xi) applying a pressurized fluid to an uphole end of said second sand screen sub and causing said second sand screen sub to flow downhole to a position in said tubular liner where said screen mesh thereon underlies said second set of frac, and causing said resiliently-outwardly biased protuberance on said second sand screen sub to engage a mating profile on an interior of said tubular liner proximate said second set of frac ports so as to thereby retain said second sand screen sub and said annular screen mesh thereof underlying said second set of frac ports;

49. A method for fracking a hydrocarbon formation at a plurality of clustered contiguous locations along a wellbore within said formation and installing sand screens within a tubular liner within said wellbore at each of said plurality of locations to prevent ingress of sand into the tubular liner at each of said locations, said method comprising the steps of:

(i) locating a tubular liner having:

- a hollow interior bore;

- a plurality of contiguous frac ports spaced along a periphery of said tubular liner;

- a corresponding plurality of sliding sleeve members respectively initially covering each of said frac ports;

within said wellbore;

(ii) situating an actuation member within said tubular liner to engage the actuation member with a first one of the plurality of sliding sleeve members, said first sliding sleeve member associated with a first set of said frac ports;

- (iii) actuating said actuation member to actuate the first sliding sleeve member to uncover and thereby open the associated first set of frac ports in said tubular liner and thereby allow fluid communication from said interior bore to an exterior of said tubular liner and said hydrocarbon formation via the opened first set of frac ports;
- (iv) continuing to actuate said actuation member to further move downhole and engage a second one of the plurality of sliding sleeve members, said second sliding sleeve member associated with a second set of said frac ports;
- (v) continuing to actuate said actuation member to actuate the first sliding sleeve member to uncover and thereby open the associated second set of frac ports in said tubular liner and thereby allow fluid communication from said interior bore to an exterior of said tubular liner and said hydrocarbon formation via the opened second set of frac ports;
- (vi) injecting a fracking fluid into said tubular liner and causing said frac fluid to flow into the hydrocarbon formation via the opened first and second sets of frac ports;
- (vii) situating a first sand screen sub within said tubular liner, said first sand screen sub having a resiliently-outwardly biased protuberance having a profile, and said first sand screen sub further having an annular screen mesh about an outer periphery thereof;
- (viii) applying a pressurized fluid to an uphole end of said first sand screen sub and causing said first sand screen sub to flow downhole to a position in said tubular liner where said annular screen mesh thereof underlies said second set of open frac ports and causing said profile of said protuberance thereon to engage a mating profile on an interior of said tubular liner and thereby retain said first sand screen sub and said annular screen mesh thereof underlying said second set of open frac ports;
- (ix) situating a second sand screen sub within said tubular liner, said second

sand screen sub having a resiliently-outwardly biased protuberance having a profile different than the profile of the protuberance on said first sand screen sub, and likewise having an annular screen mesh about an outer periphery thereof;

(x) applying a pressurized fluid to an uphole end of said second sand screen sub and causing said second sand screen sub to flow downhole to a position in said tubular liner where said annular screen mesh thereof underlies said first set of open frac ports, and causing said profile of said protuberance thereon to engage a mating profile on an interior of said tubular liner and thereby retain said second sand screen sub and said annular screen mesh thereof underlying said first set of open frac ports.

50. The method as claimed in claim 49, further comprising the step, after step (v), of injecting pressurized fluid into said interior bore at a pressure sufficient to rupture a burst disk member located on said first or second sand screen sub, so as to thereafter allow fluid to flow through said first or second sand screen sub.

51. The method as claimed in claim 49, further comprising the step, after step (v), of exposing said actuation member to a corrosive fluid so as to dissolve a portion of said actuation member so as to thereafter allow fluid to flow through said actuation member.

52. The method as claimed in claim 49, further comprising the step, sometime after step (iv), of exposing said actuation member to a corrosive fluid so as to dissolve all or substantially all of said actuation member.

53. The method as claimed in claim 49, further comprising the step, after step (vi), of exposing said first sand screen sub to a corrosive fluid so as to dissolve a portion of said first sand screen sub so as to thereafter allow fluid to flow longitudinally through said first sand screen sub.

54. The method as claimed in claim 49, further comprising the step after step (viii), of exposing said second sand screen sub to a corrosive fluid so as to dissolve a portion of said second sand screen sub so as to thereafter allow fluid to flow longitudinally through said second sand screen sub.

55. A method for successively uncovering spaced-apart frac ports situated along a hollow tubular liner, carrying out a fracking operation at each uncovered frac port, and installing a sand screen at each of said uncovered frac ports, comprising the steps of:

(i) locating an actuation member in said tubular liner, said tubular liner initially having a plurality of sliding sleeve members respectively covering a corresponding plurality of said spaced-apart frac ports along said tubular liner;

(ii) flowing said actuation member downhole one of the plurality of sliding sleeve members covering an lowermost covered frac port along said tubular liner, and actuate said actuation member and said lowermost sliding sleeve member to together move downhole and thereby uncover an associated of said ports in said tubular liner;

(iii) injecting a pressurized frac fluid into said tubular liner to frac the formation at the location of the opened frac port;

(iv) injecting a sand screen sub down said tubular liner, said sand screen sub having a resiliently-outwardly biased protruding member thereon, wherein upon the sand screen sub reaching said first actuation member, the resiliently-outwardly biased protruding member then engages a mating profile on an interior of said tubular liner and thereby retains the sand screen sub in a position underlying said opened port and said protruding member thereafter prevents said sand screen sub from moving back uphole; and

(v) repeating steps (i)-(iv) until all of said plurality of spaced-apart ports along said tubular liner have been uncovered, the wellbore fracked at each opened frac port, and sand screen subs installed at each opened frac port.

56. A sand screen sub insertable within an interior bore of a tubular liner and displaceable within said tubular liner to a location therein proximate one or more opened frac ports in said tubular liner, said sand screen sub comprising:

(a) a cylindrical hollow member having at an uphole end thereof a dissolvable plug member or burst plate, said dissolvable plug member or burst plate being

configured for, when said sand screen sub is inserted within the interior bore, at least for a limited time substantially obstructing passage of fluid within said interior bore thereby causing pressurized fluid injected downhole in said bore of said tubular liner to force said sand screen sub downhole in said tubular liner; and

(b) a cylindrical, longitudinally-extending oil-permeable screen mesh forming a portion of an outer periphery of said sand screen sub downhole from said dissolvable plug member or burst plate thereon, wherein said screen mesh is configured for, when said sand screen sub is located proximate said one or more opened frac ports, underlying said one or more opened frac ports, and preventing ingress of sand but permitting ingress of oil, from said formation into the interior bore via said one or more opened frac ports.

57. The sand screen sub as claimed in claim 56 further comprising:

(c) a resiliently outwardly biased retaining member configured for directly or indirectly engaging with a mating profile on said tubular liner and preventing uphole displacement of said sand screen sub in said tubular liner when said sand screen sub has flowed down said tubular liner to said one or more opened frac ports, and the screen mesh of said sand screen sub underlies said one or more opened frac ports.

58. The sand screen sub as claimed in claim 57, wherein said resiliently outwardly biased retaining member on said at least one sand screen sub has a chamfer on a downhole side edge thereof and a flat face on an uphole side edge thereof perpendicularly disposed to a longitudinal axis of said tubular liner; and

wherein downhole movement of said at least one sand screen sub in said tubular liner is allowed by said chamfer causing said resiliently outwardly biased retaining member to become radially depressed upon fluid pressure being exerted on an uphole side of said sand screen sub; and

wherein uphole movement in said sand screen sub is prevented, when said screen mesh of said sand screen sub underlies said one or more opened frac ports, by said flat face engaging, directly or indirectly, an annular region in said tubular liner.

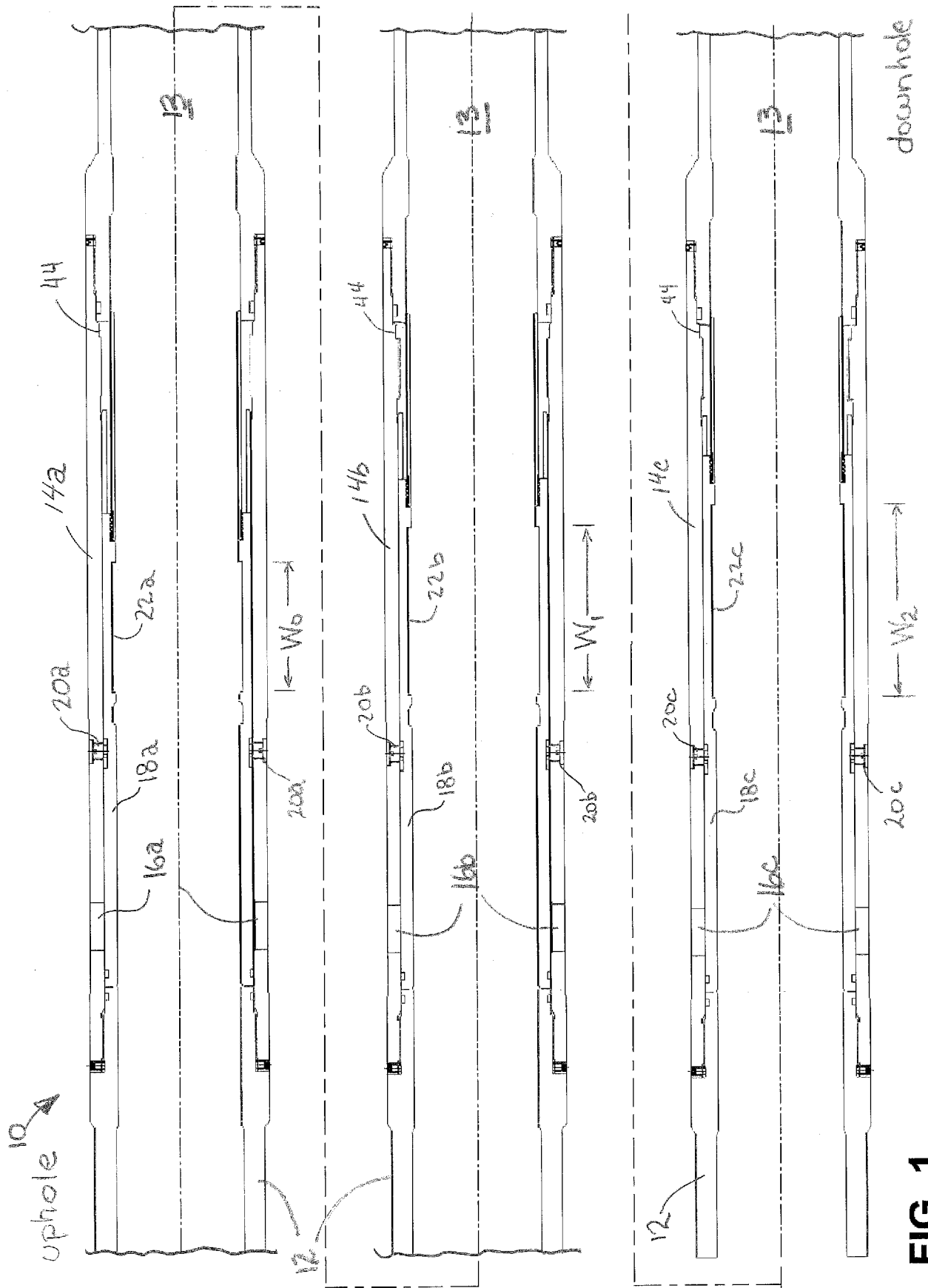

FIG. 1

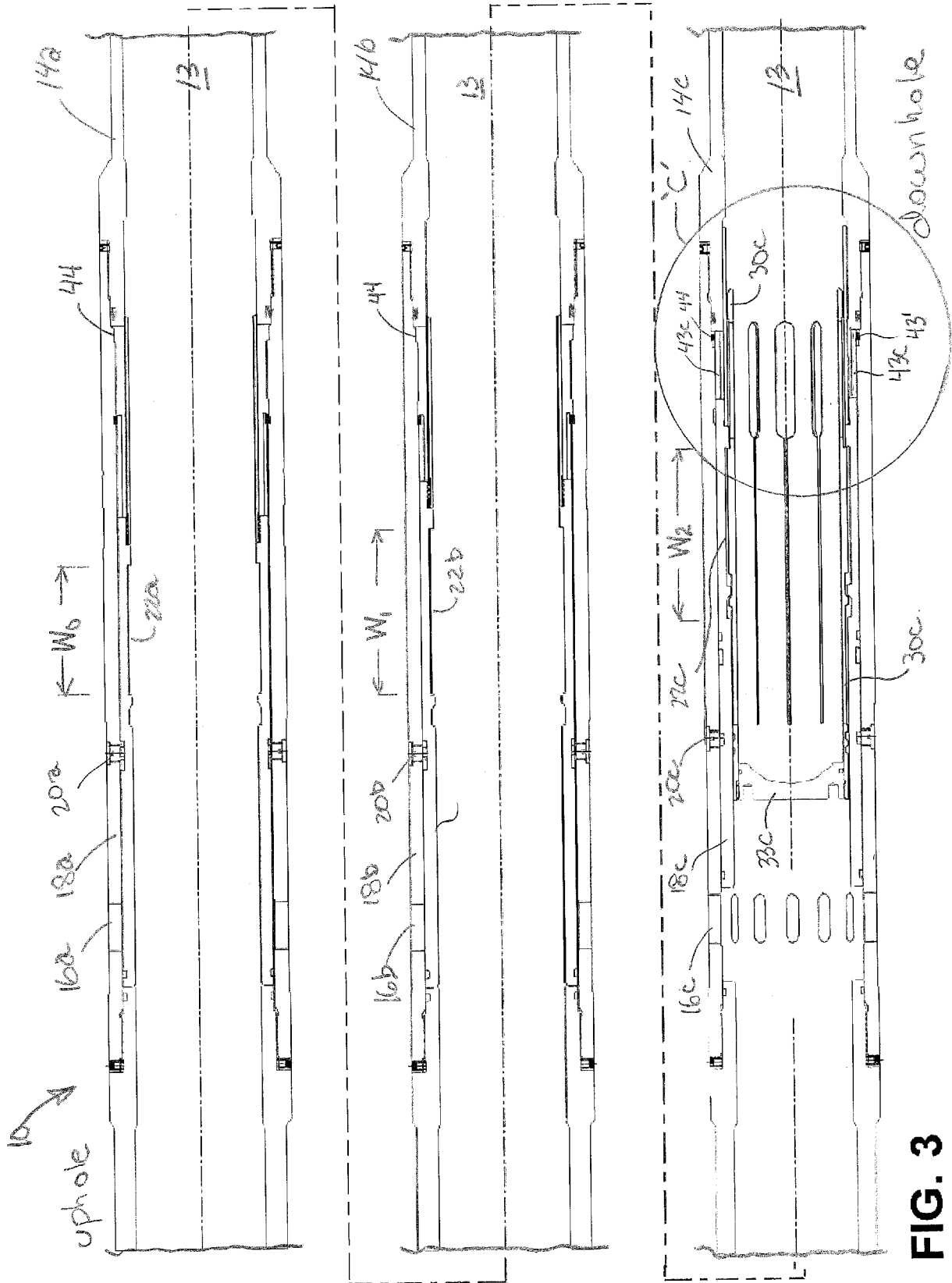

FIG. 3

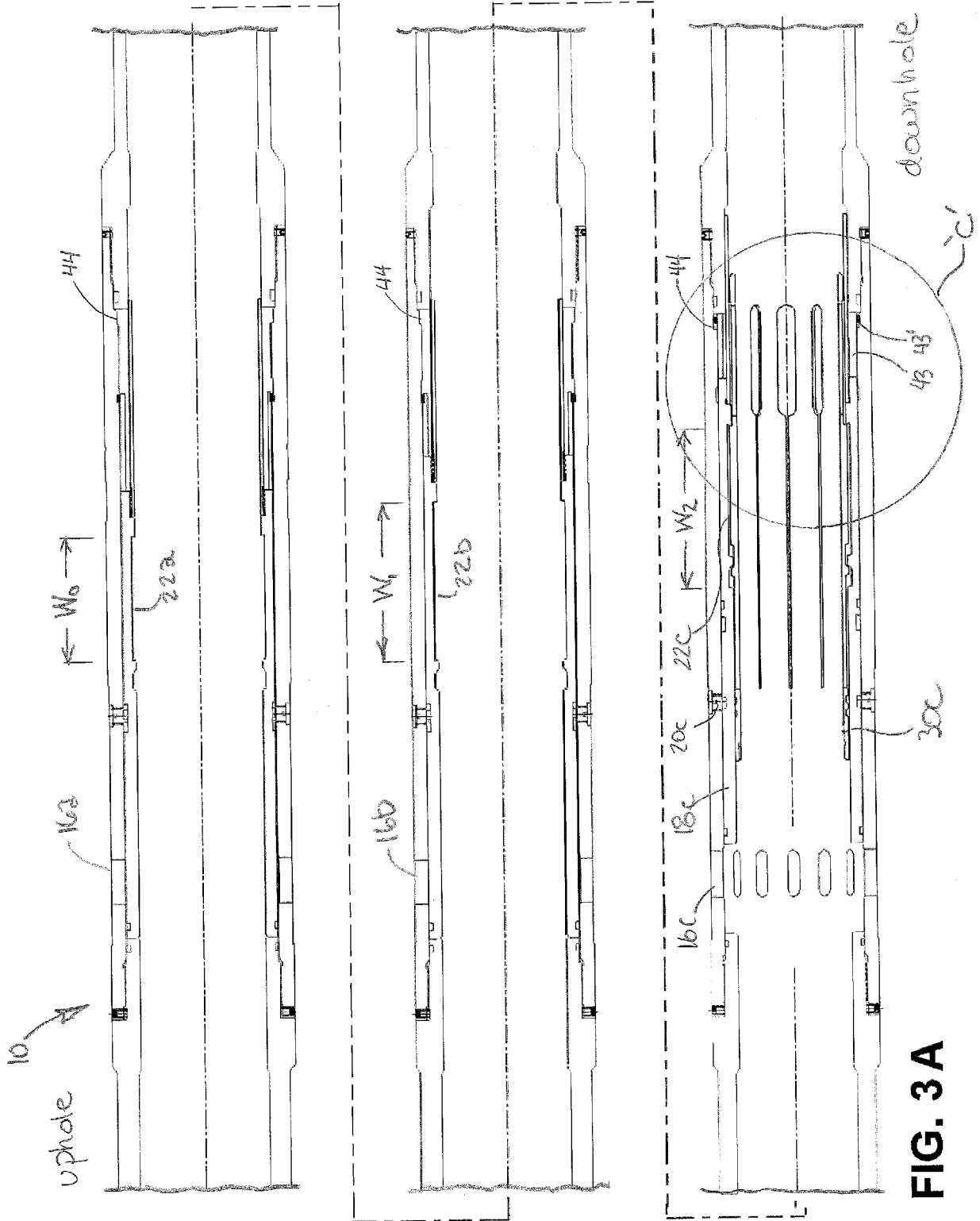

FIG. 3A

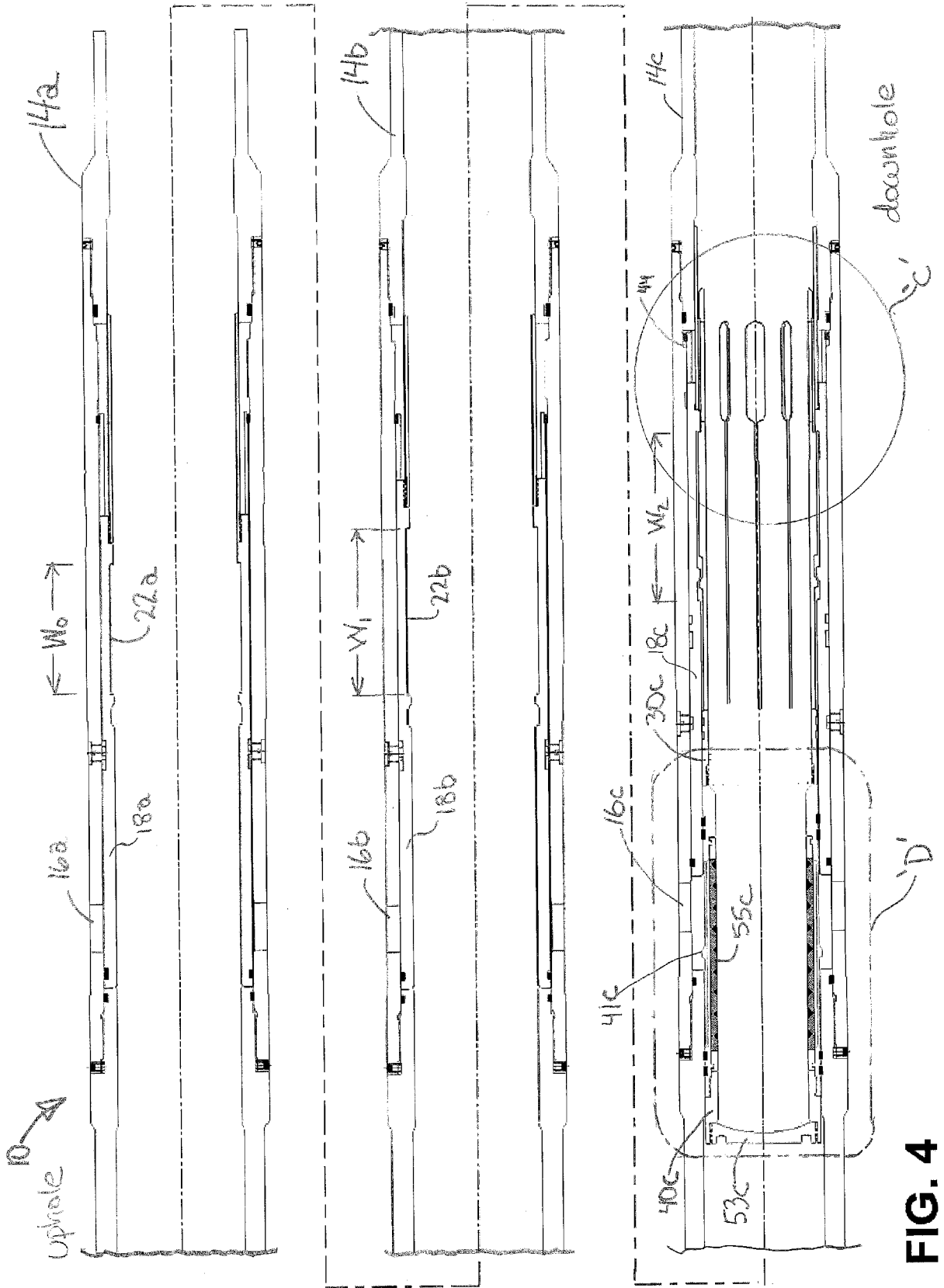

FIG. 4

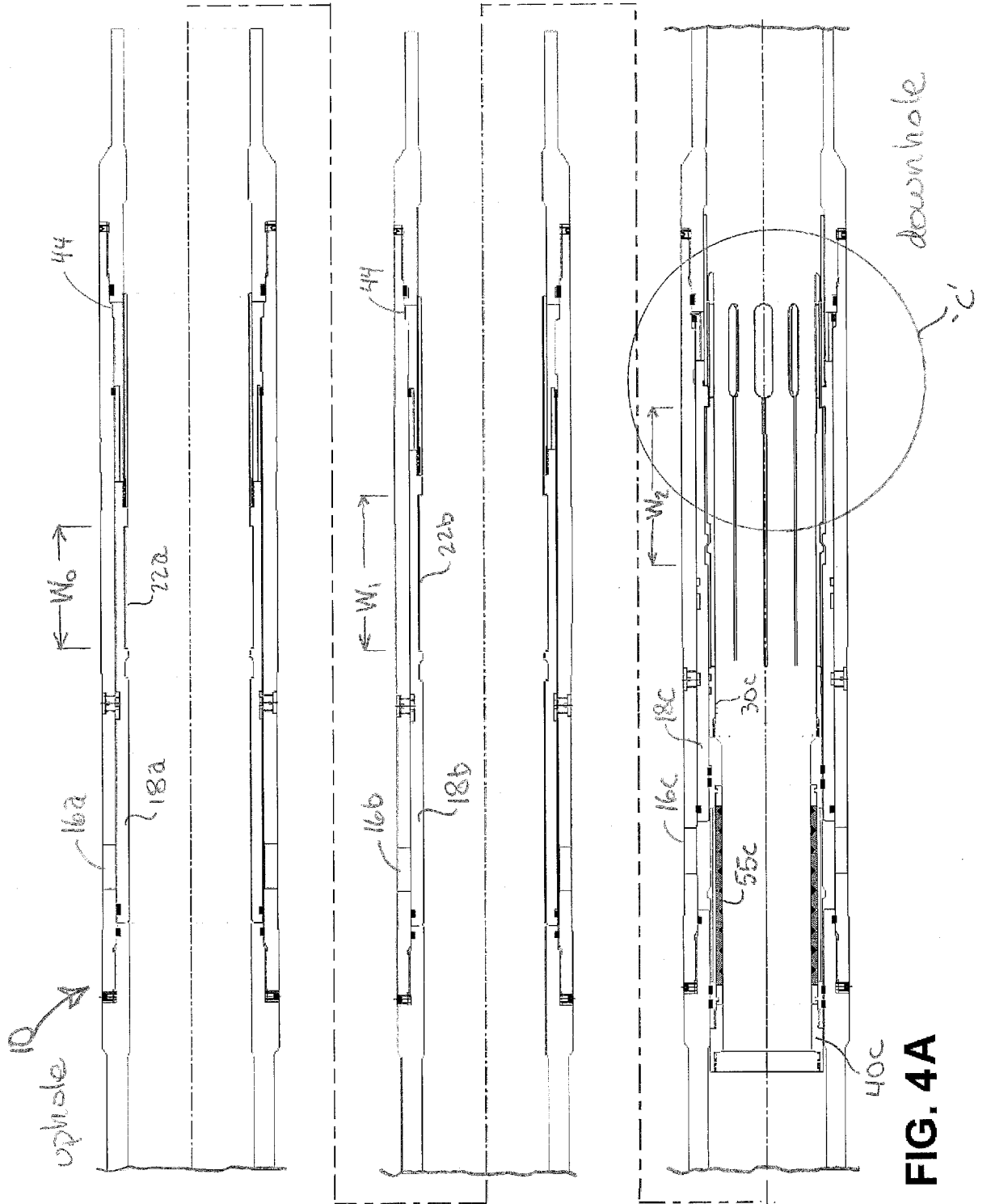

FIG. 4A

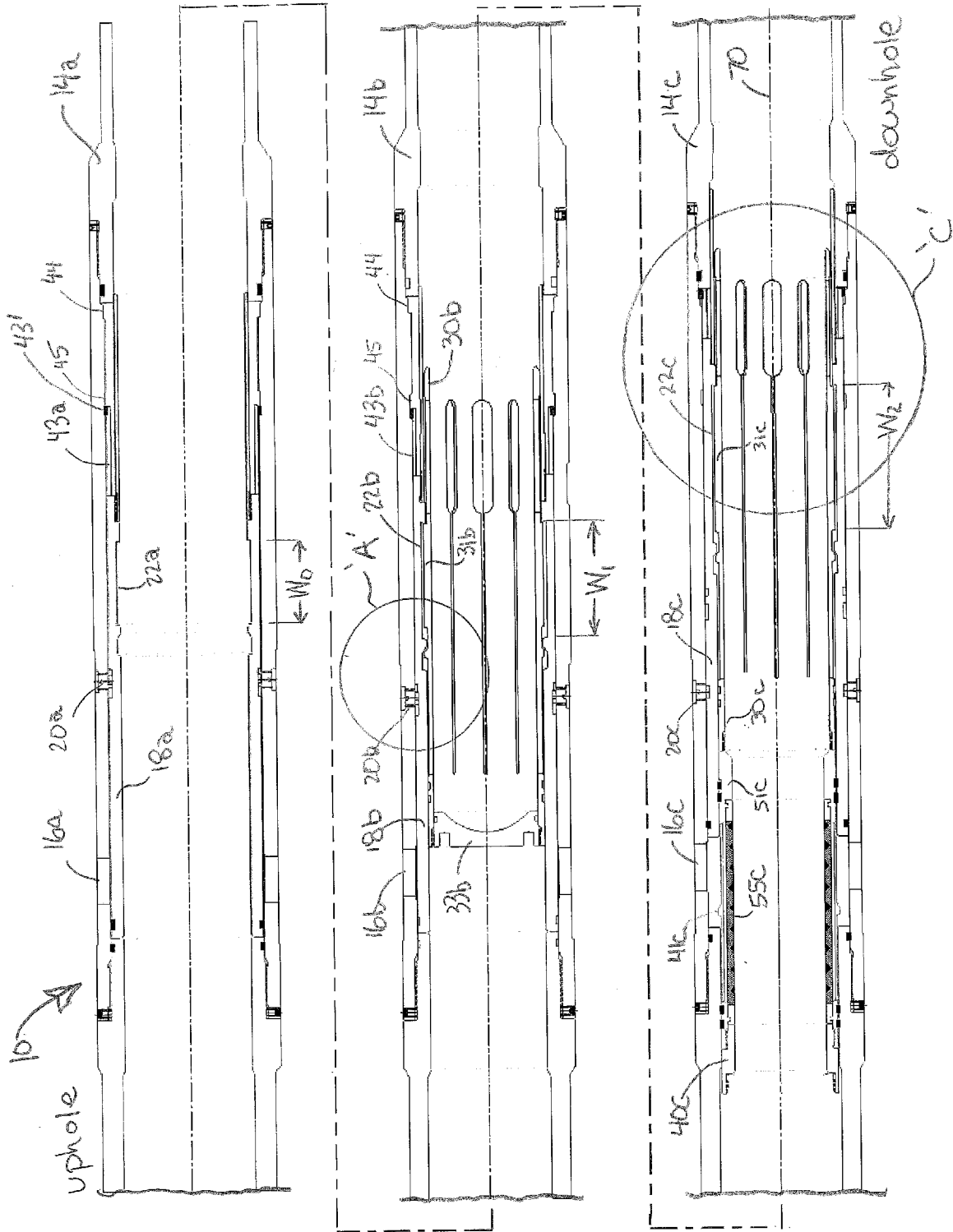

FIG. 5

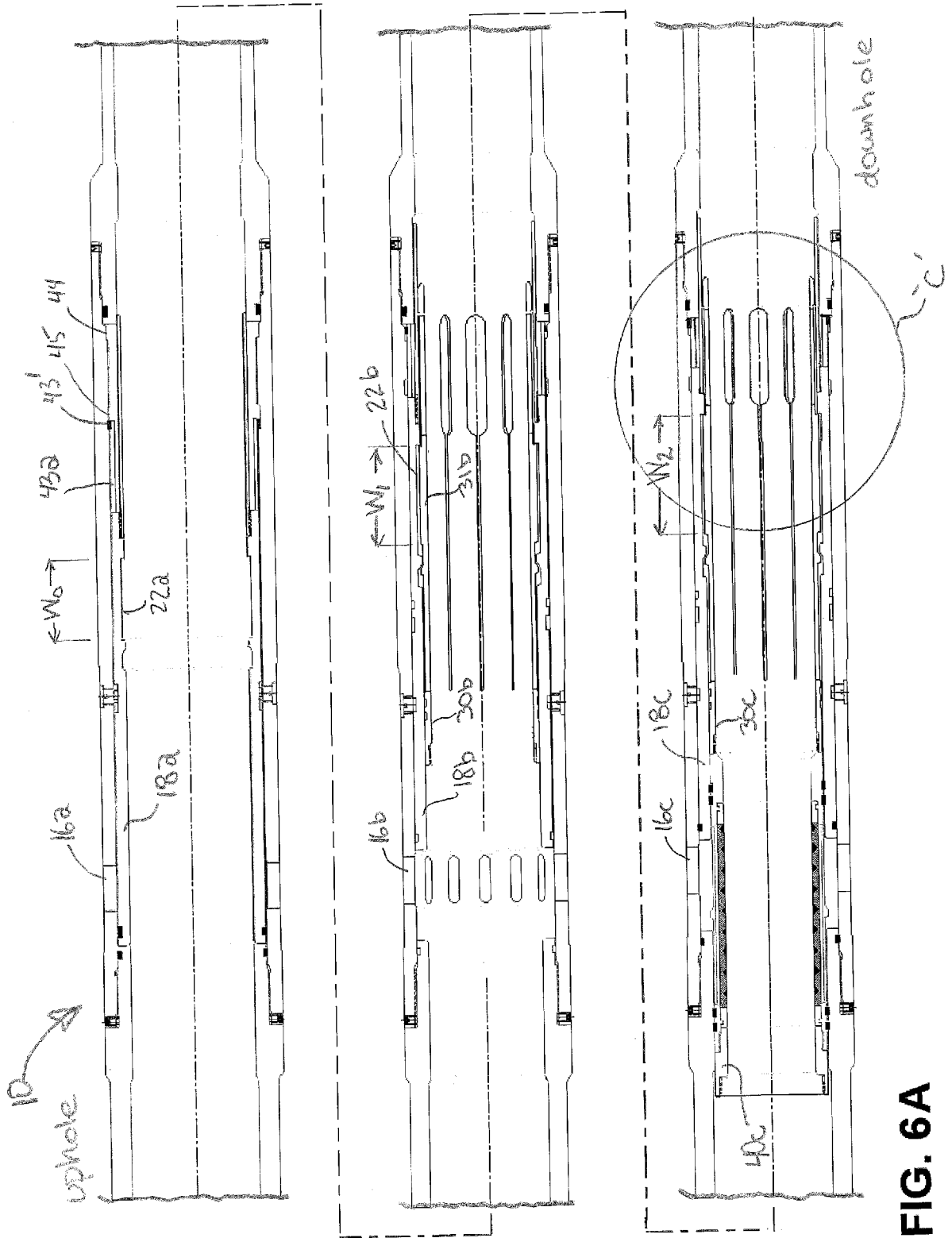

FIG. 6A

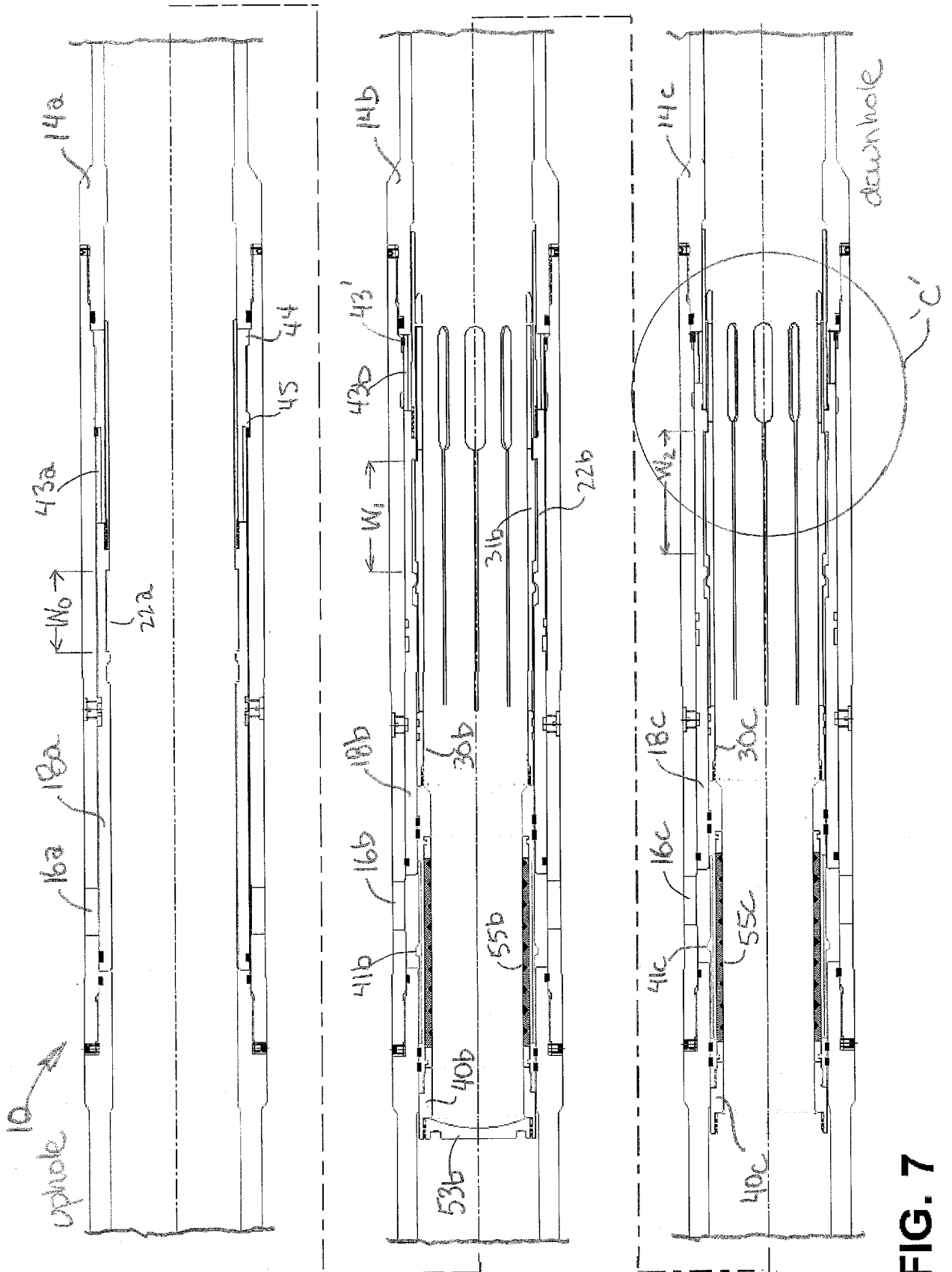

FIG. 7

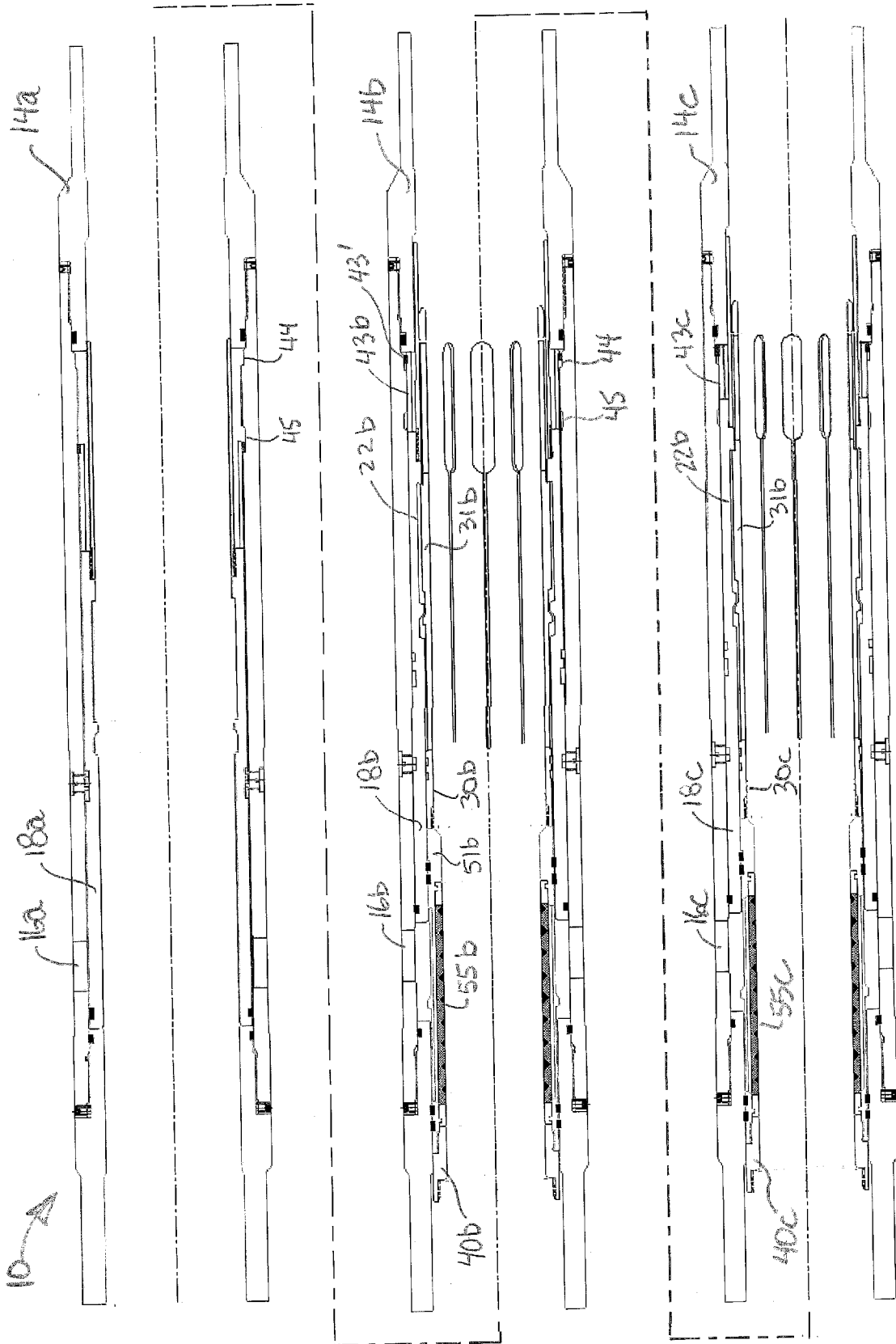

FIG. 7A

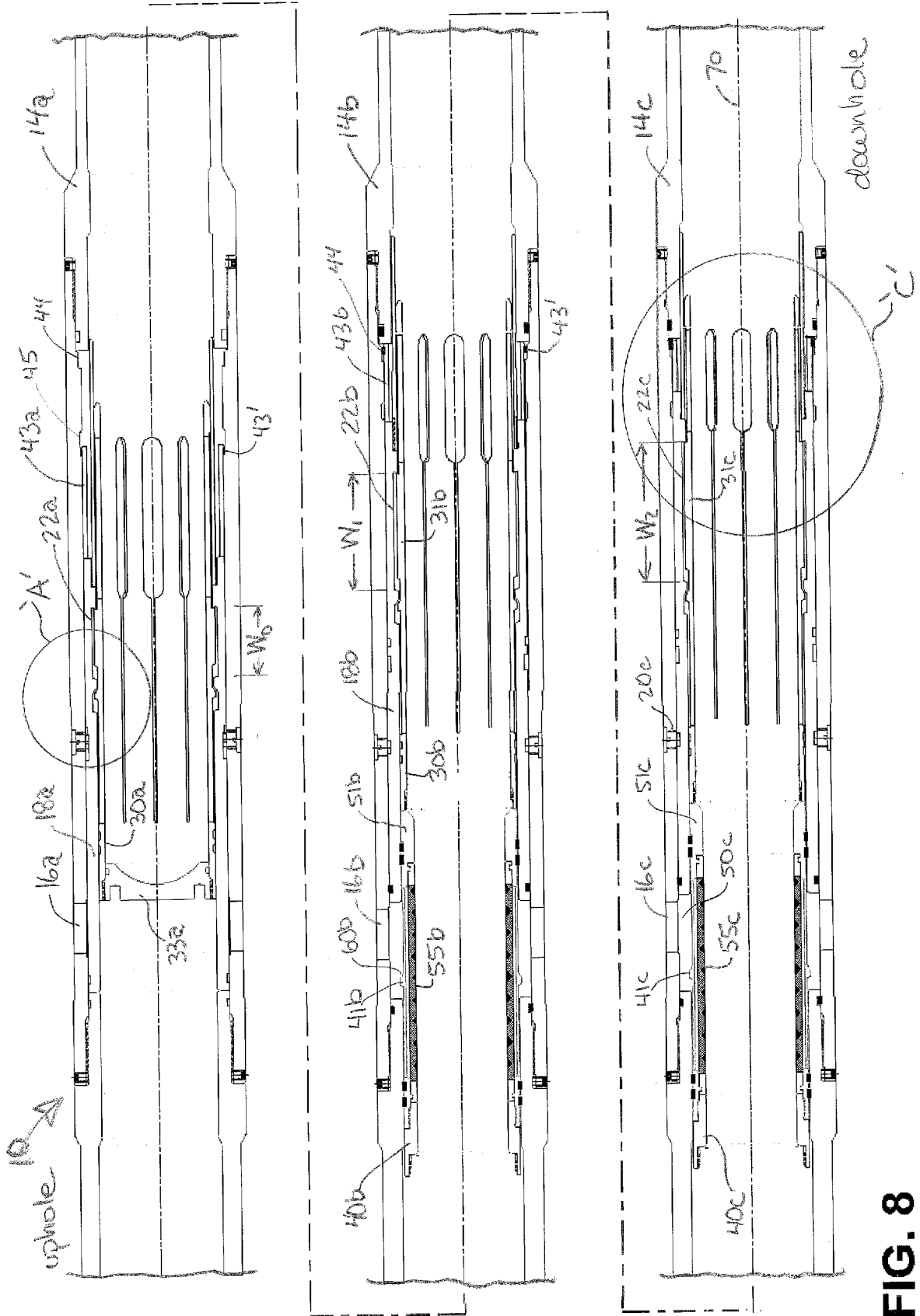

FIG. 8

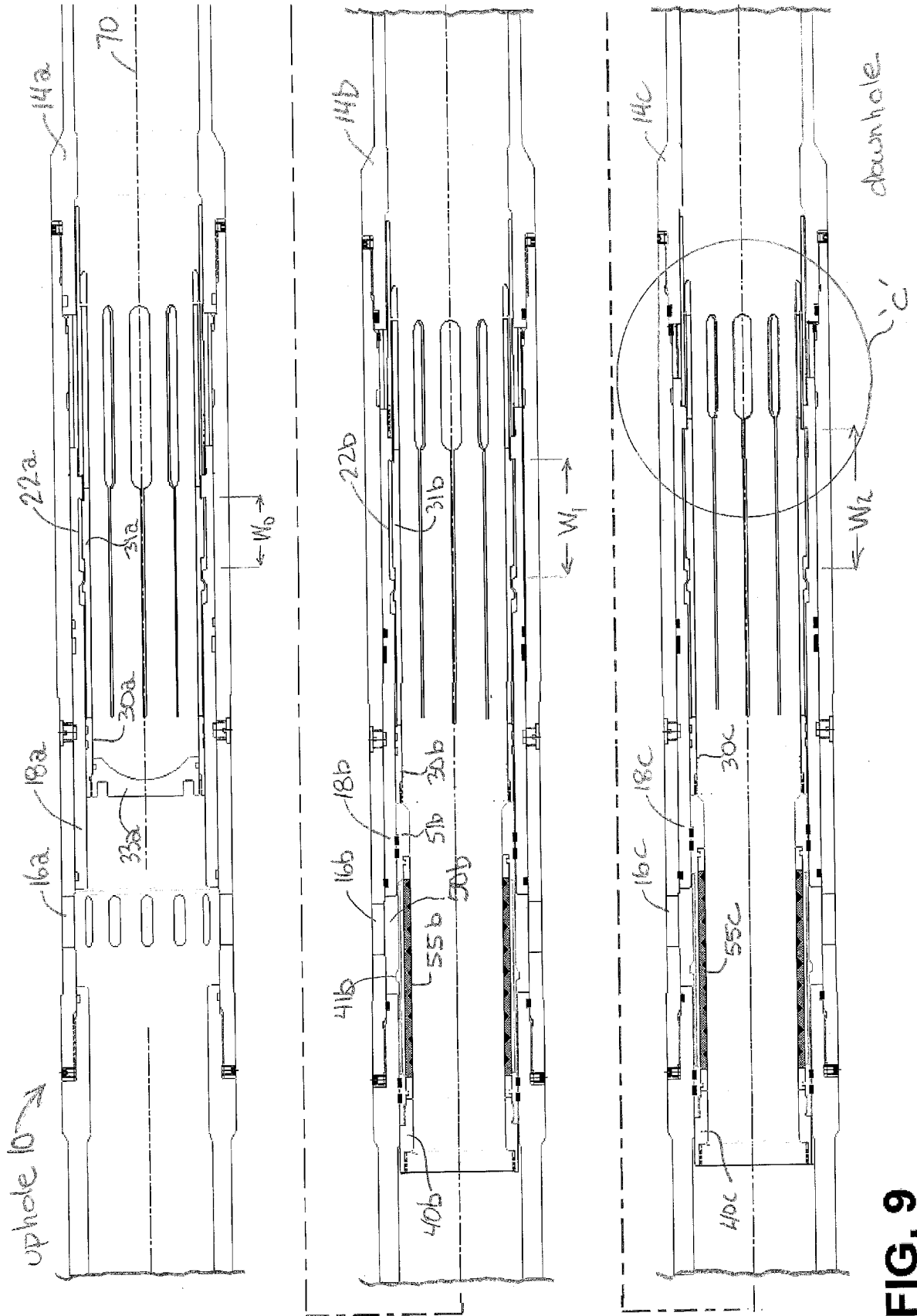

FIG. 9

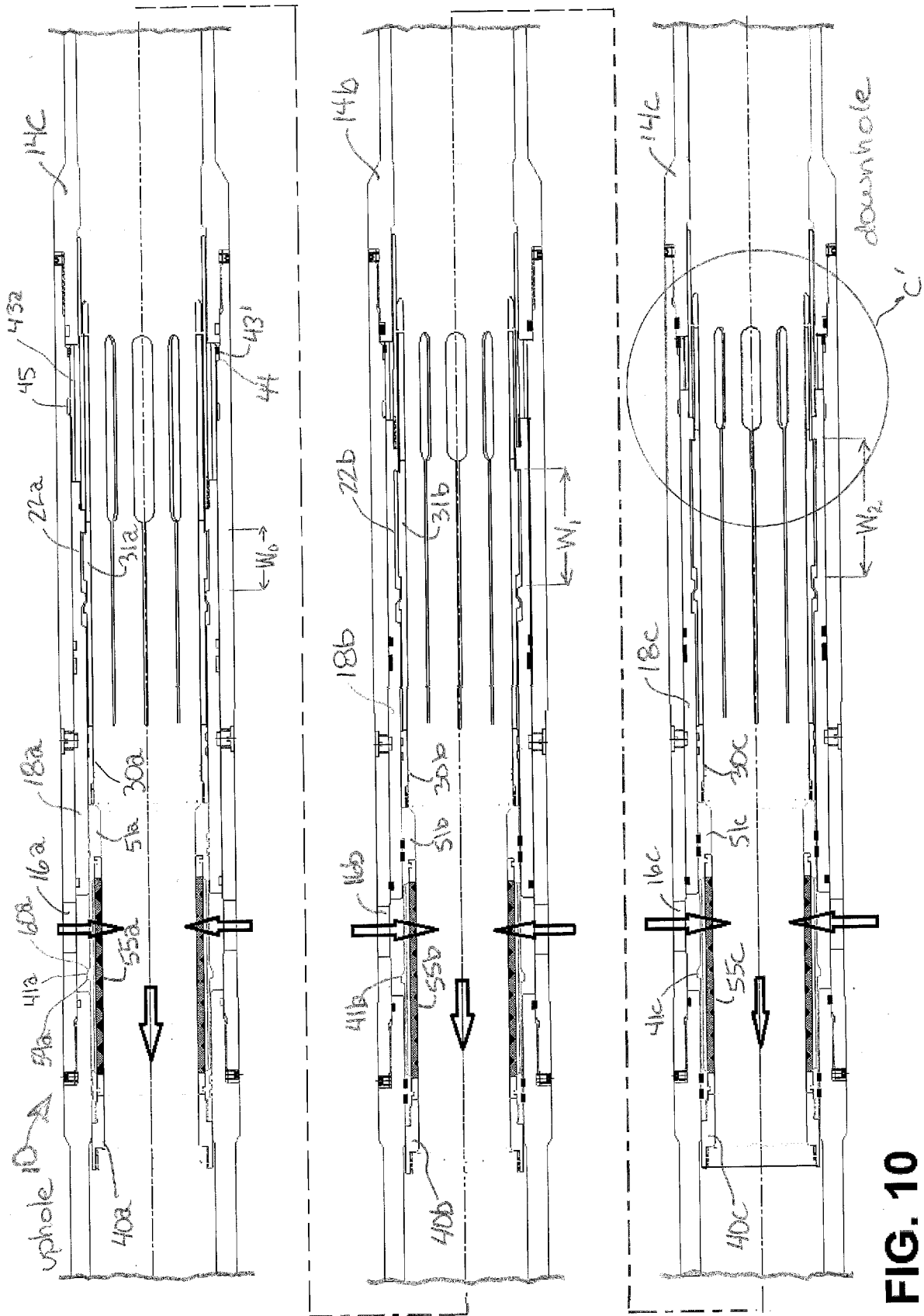

FIG. 10

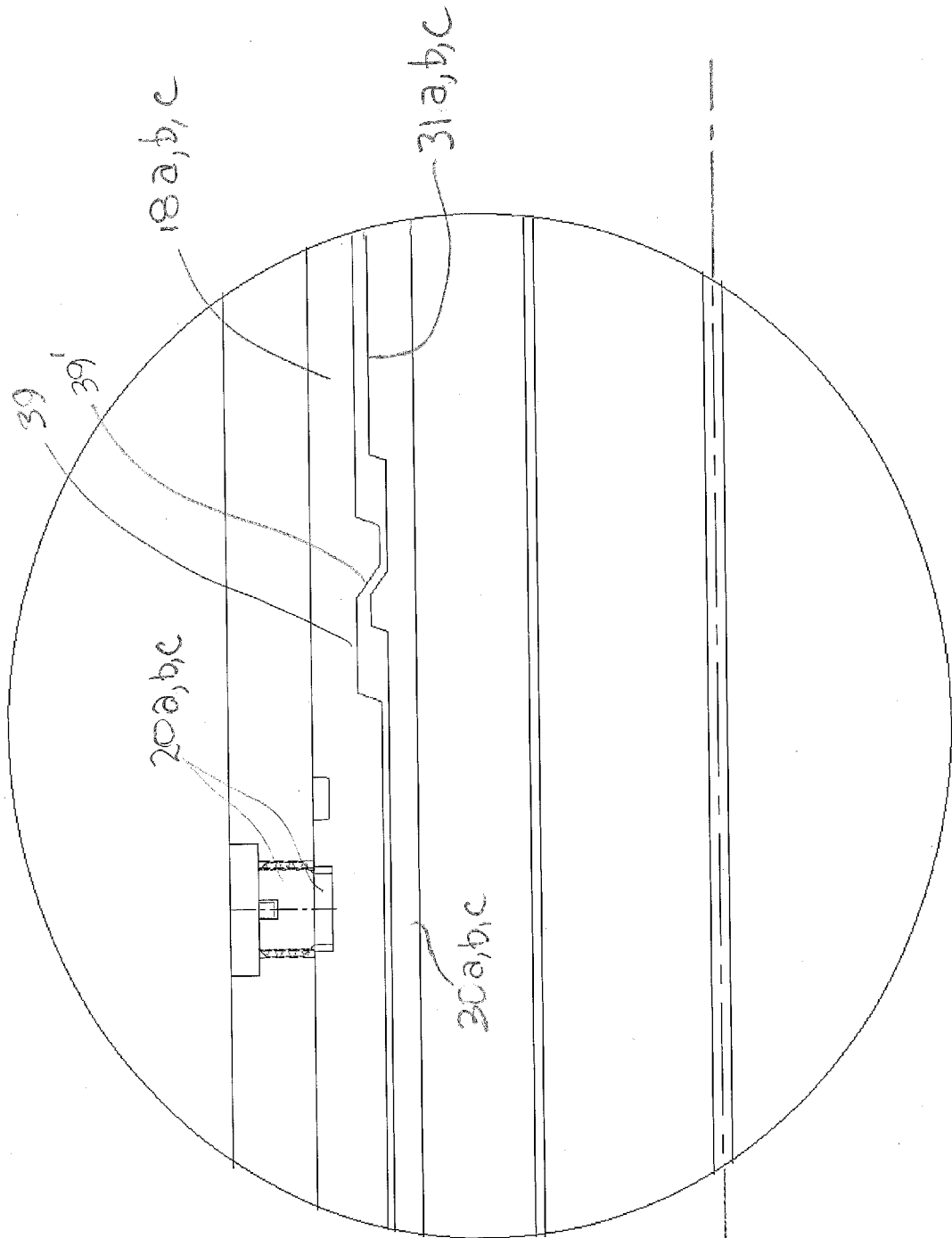

FIG. 11

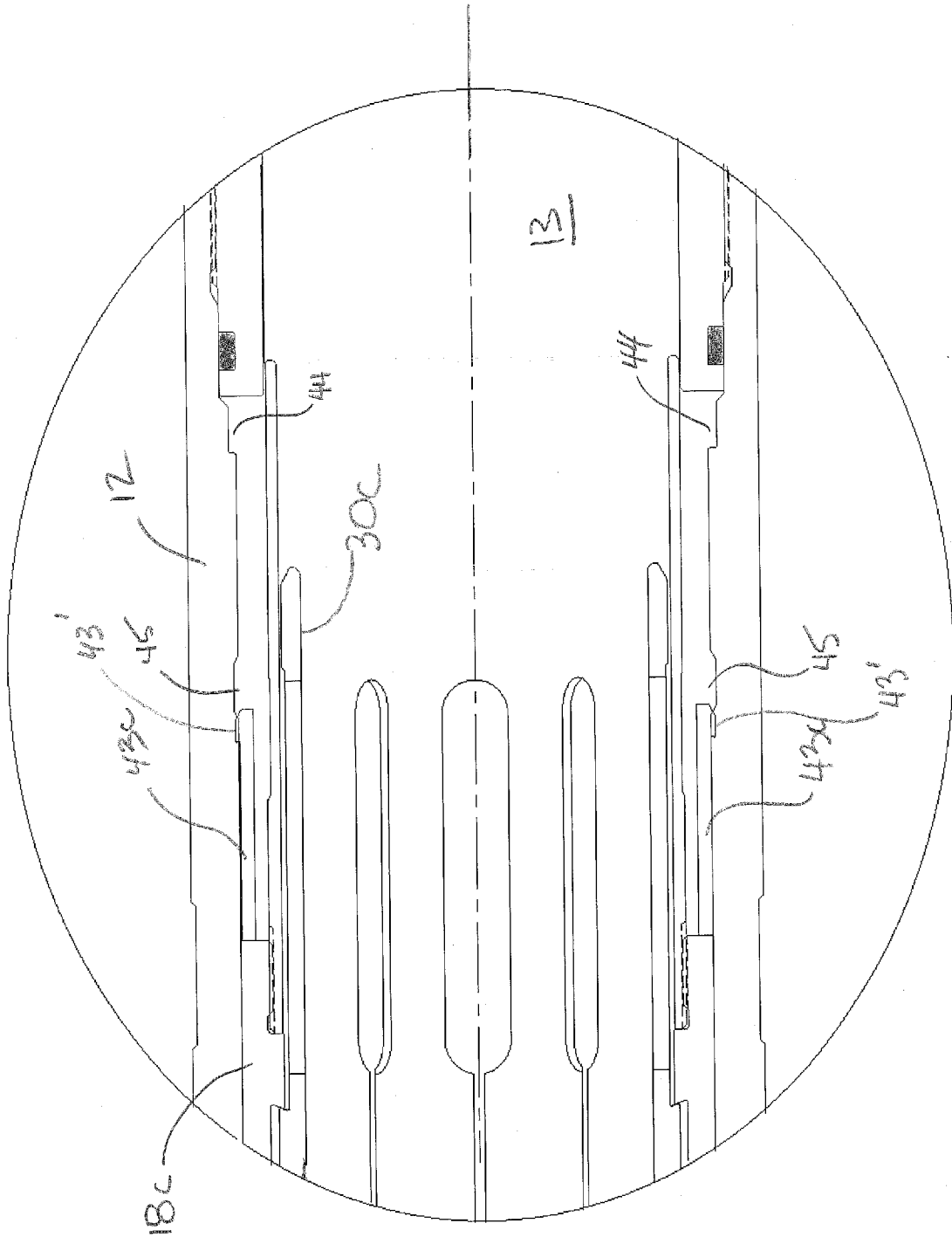

FIG. 12

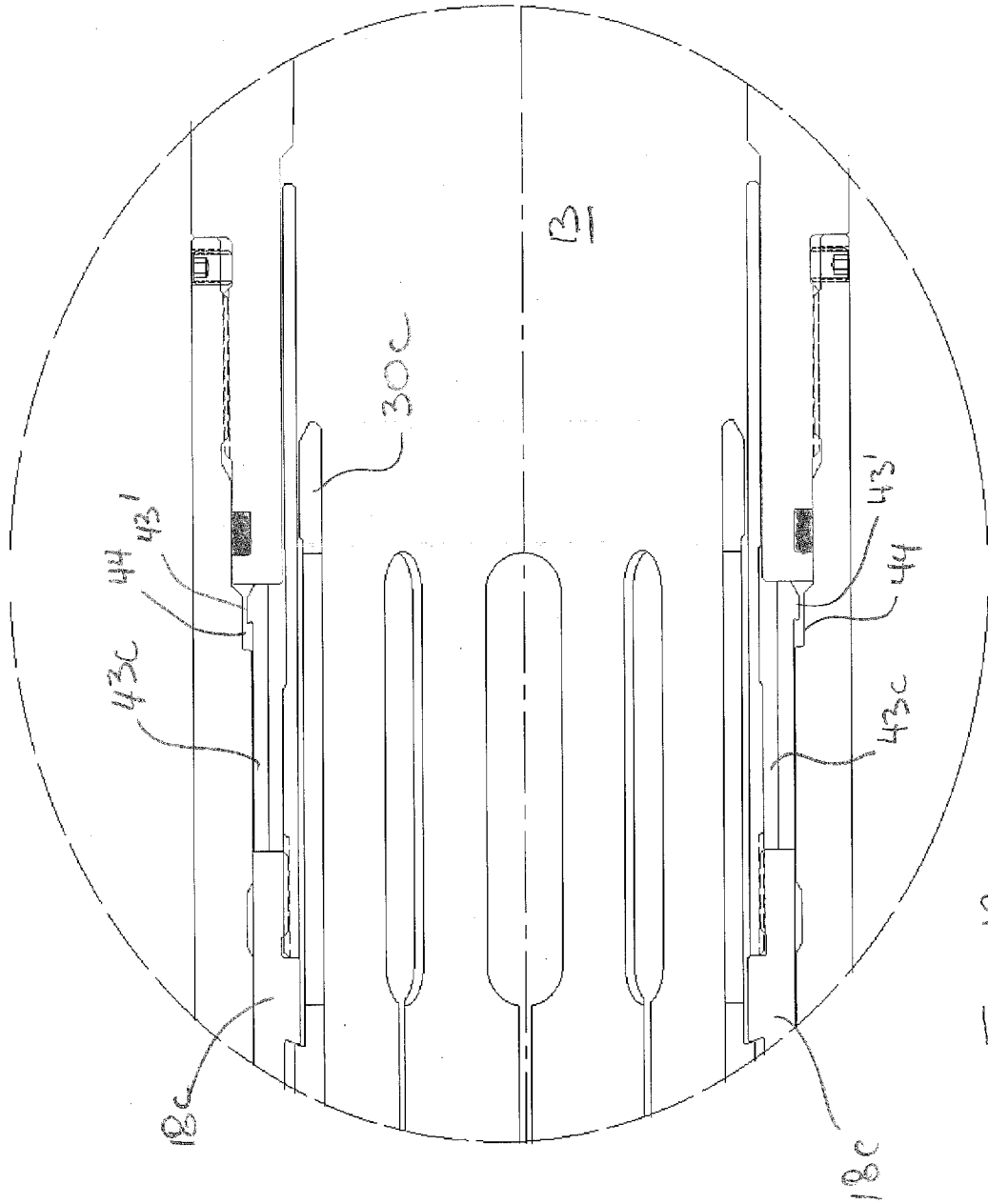

FIG. 13

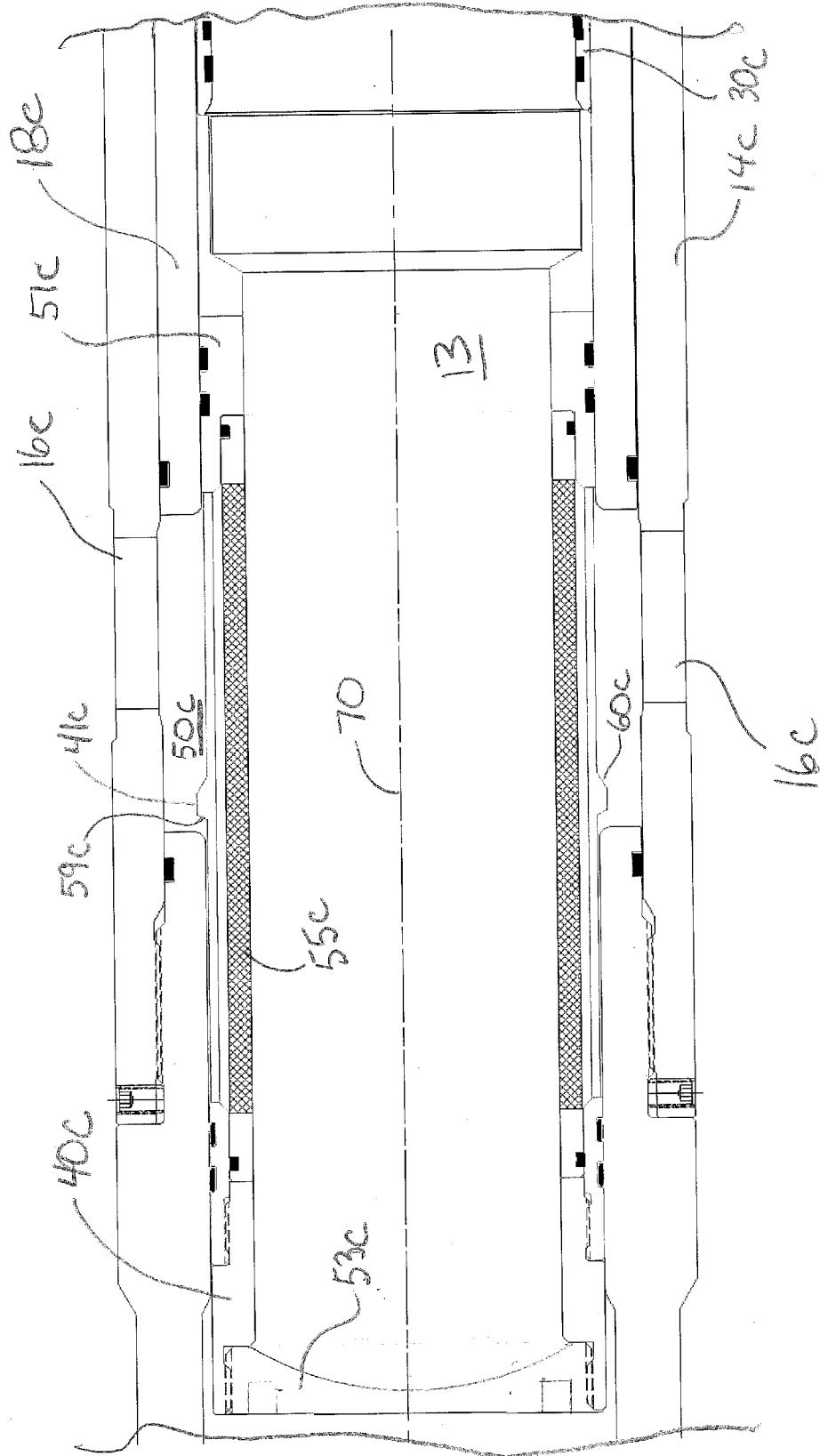
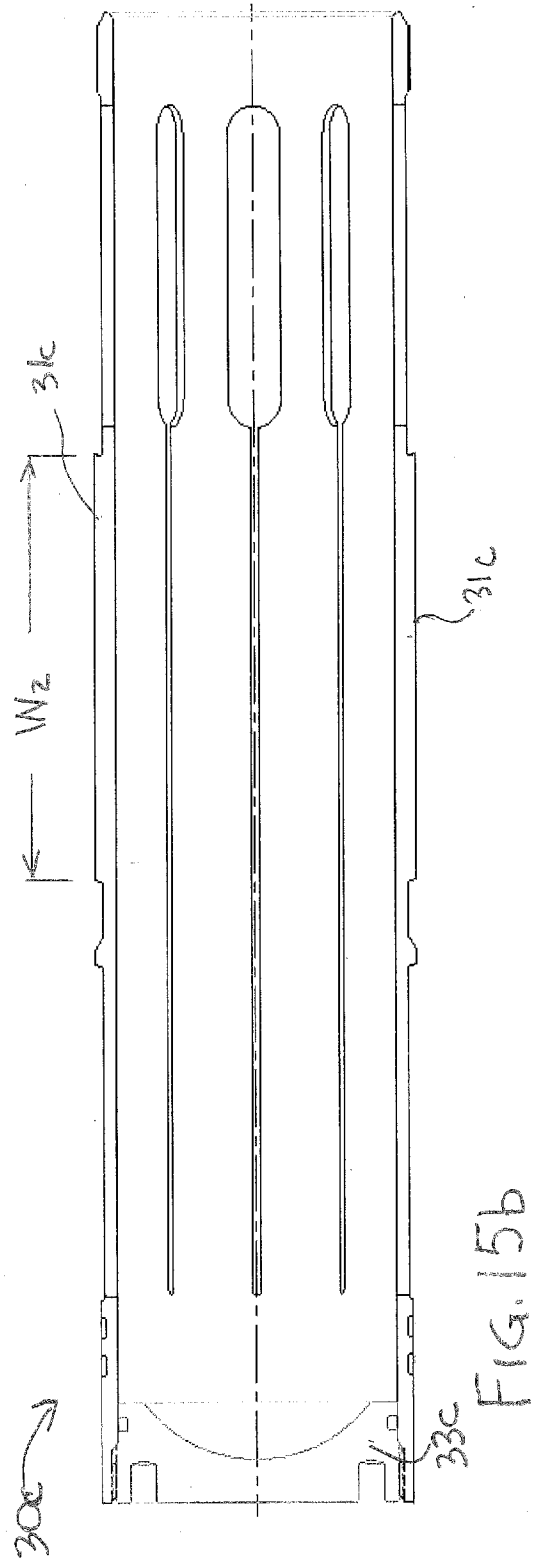
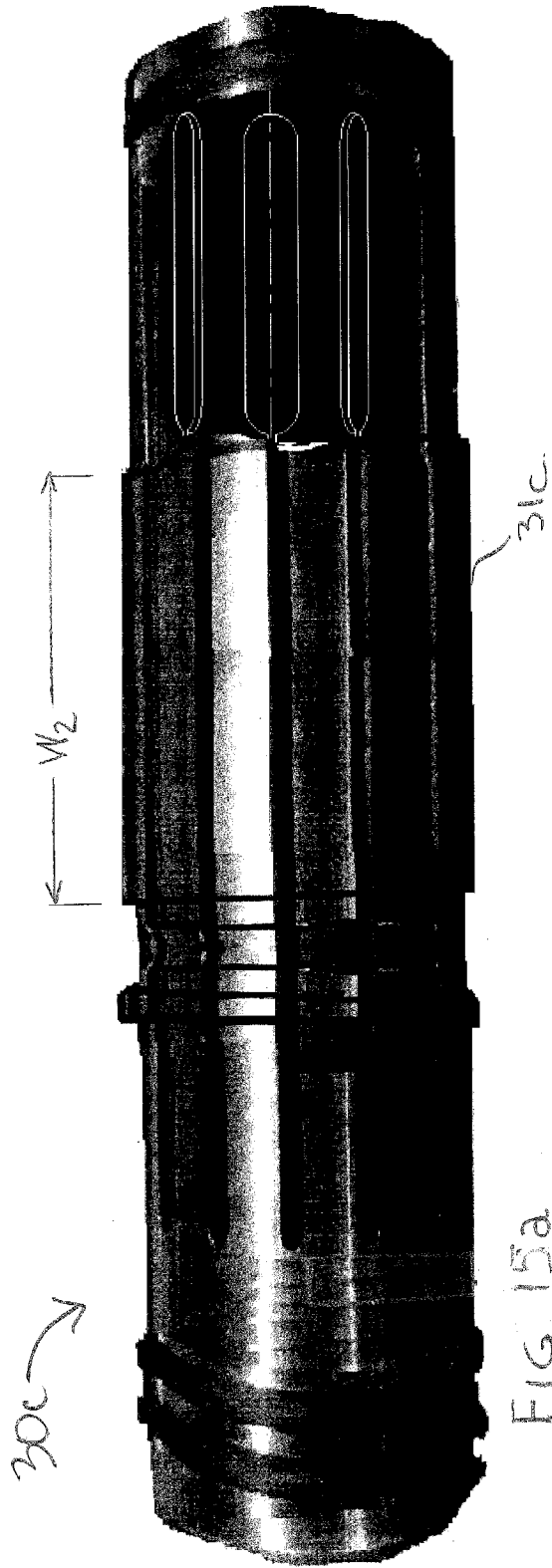

FIG. 14



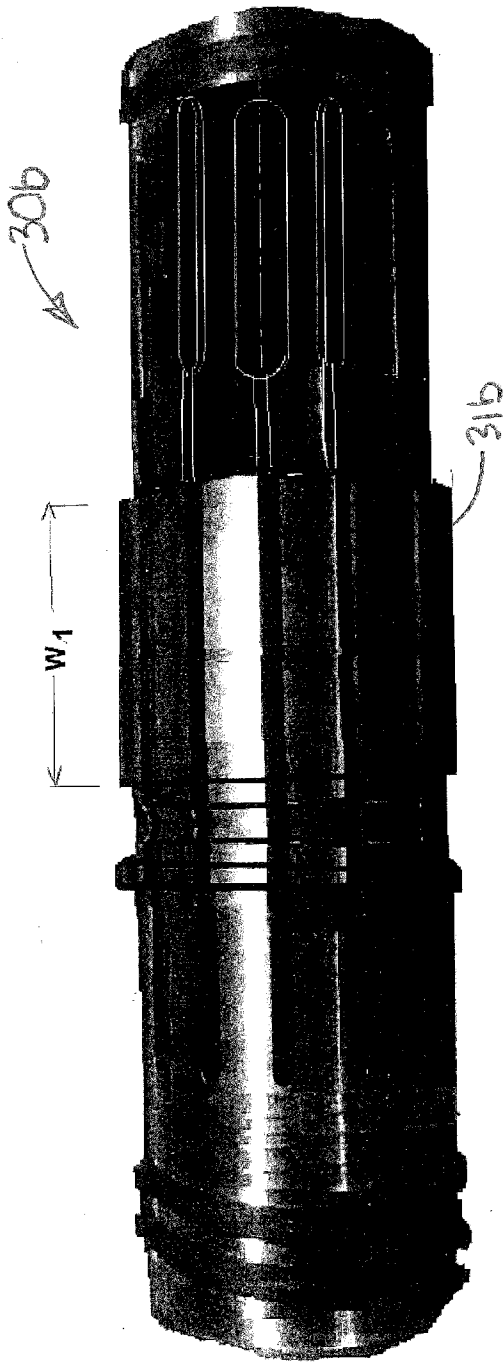

FIG. 15c

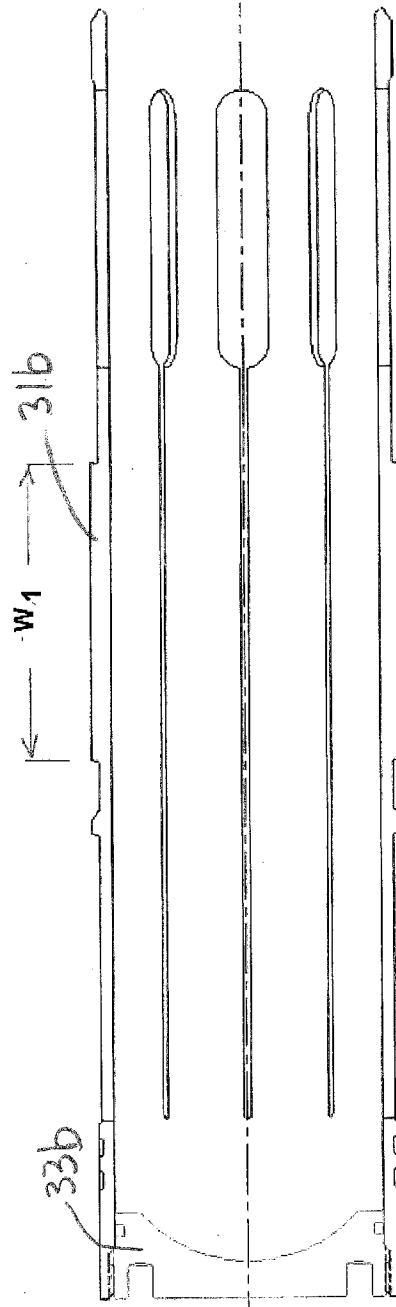

FIG. 15d

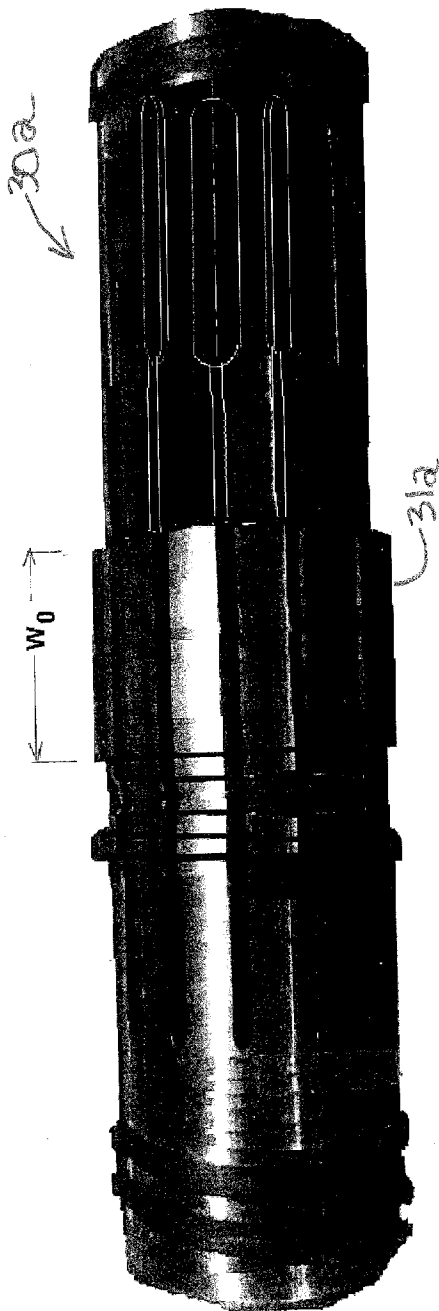

FIG. 15e

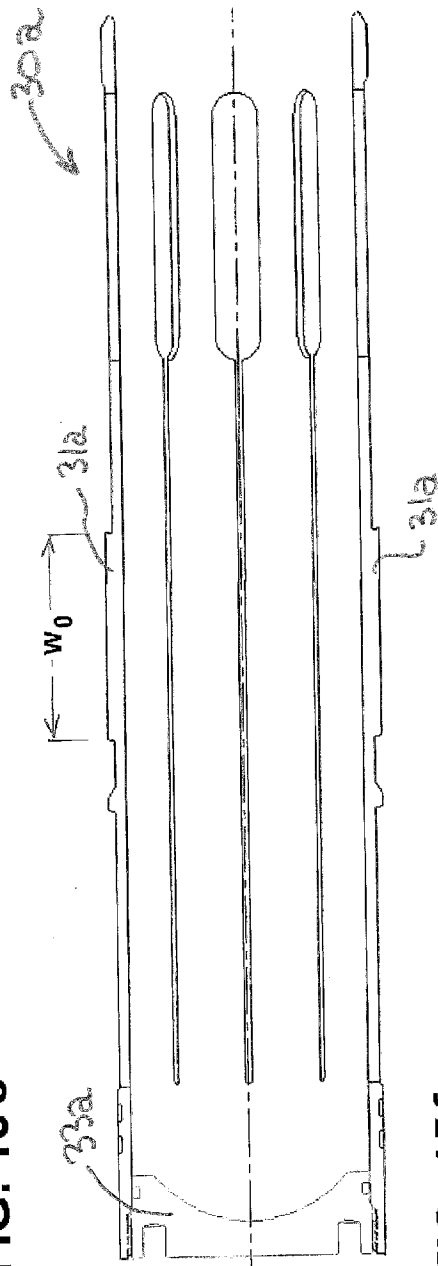

FIG. 15f

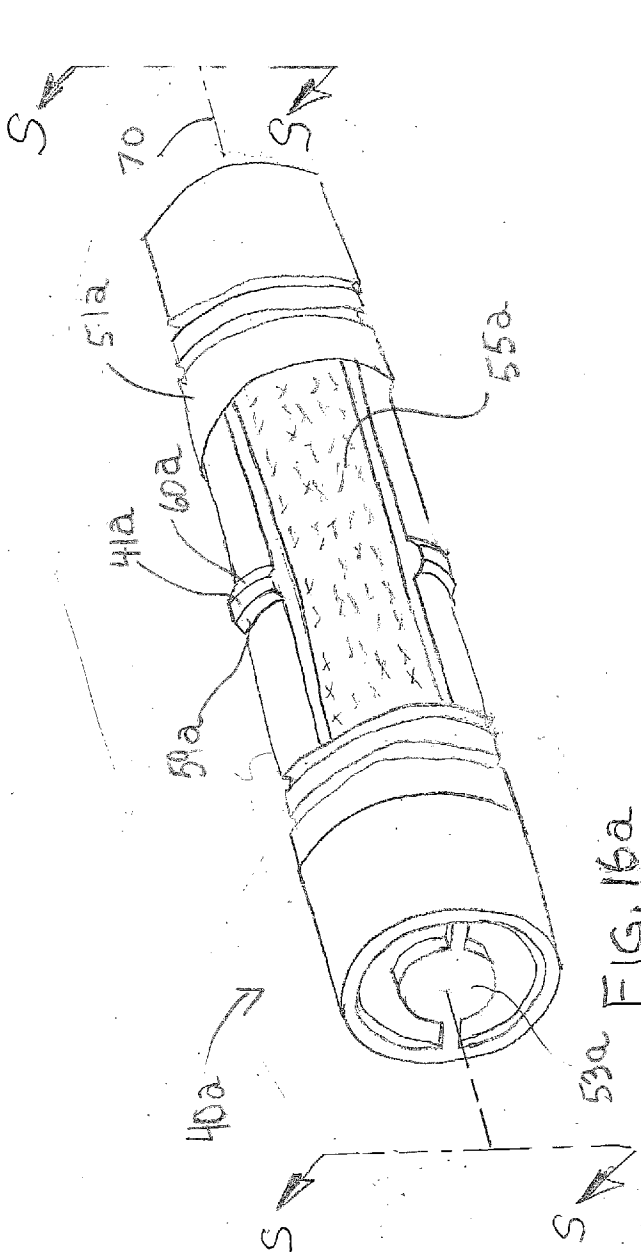

FIG. 16a

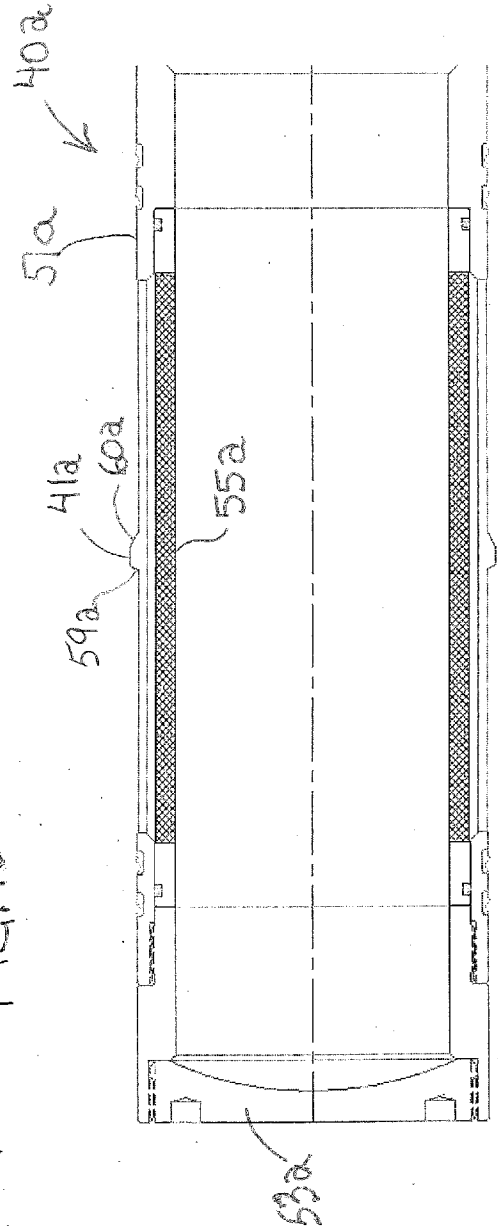

FIG. 16b

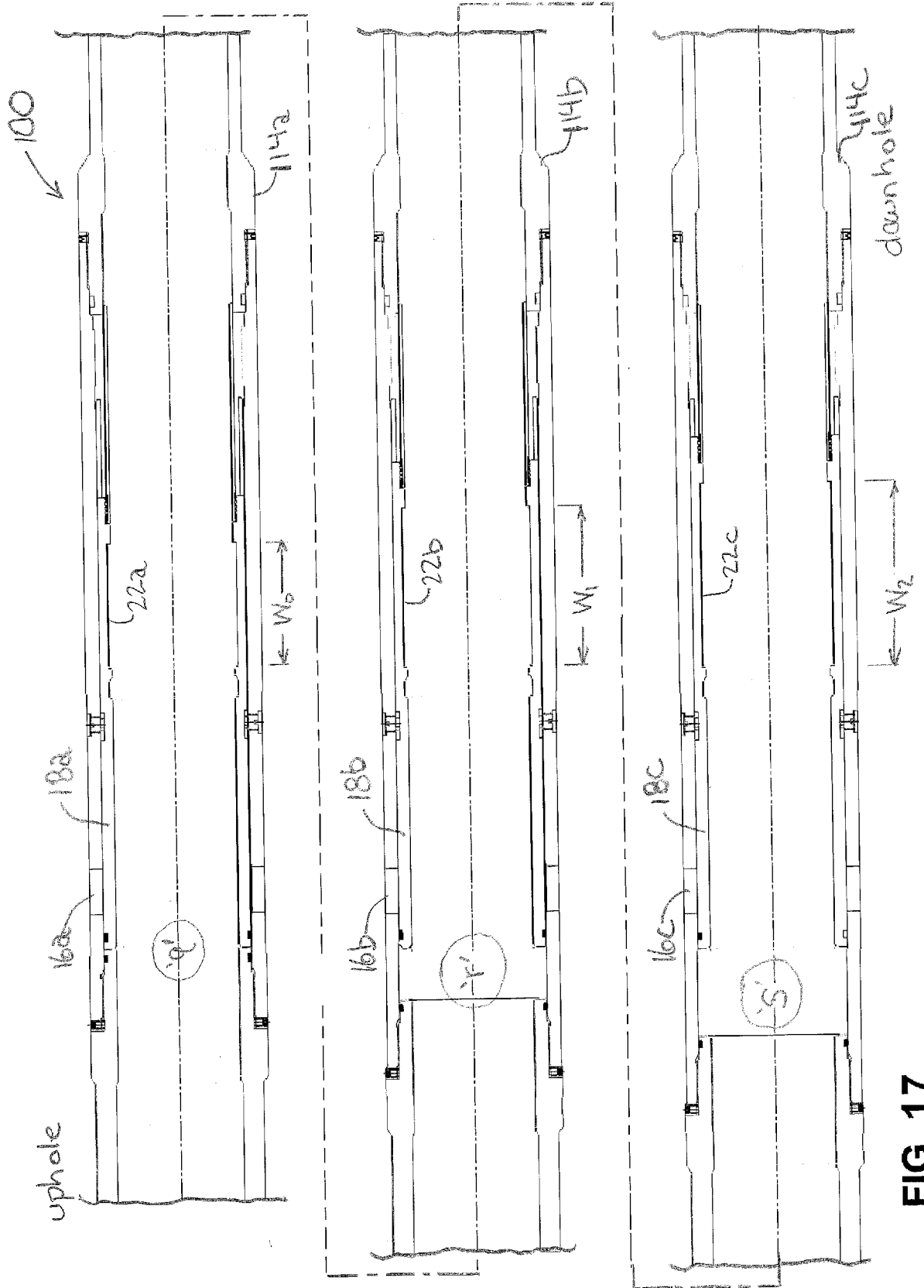

FIG. 17

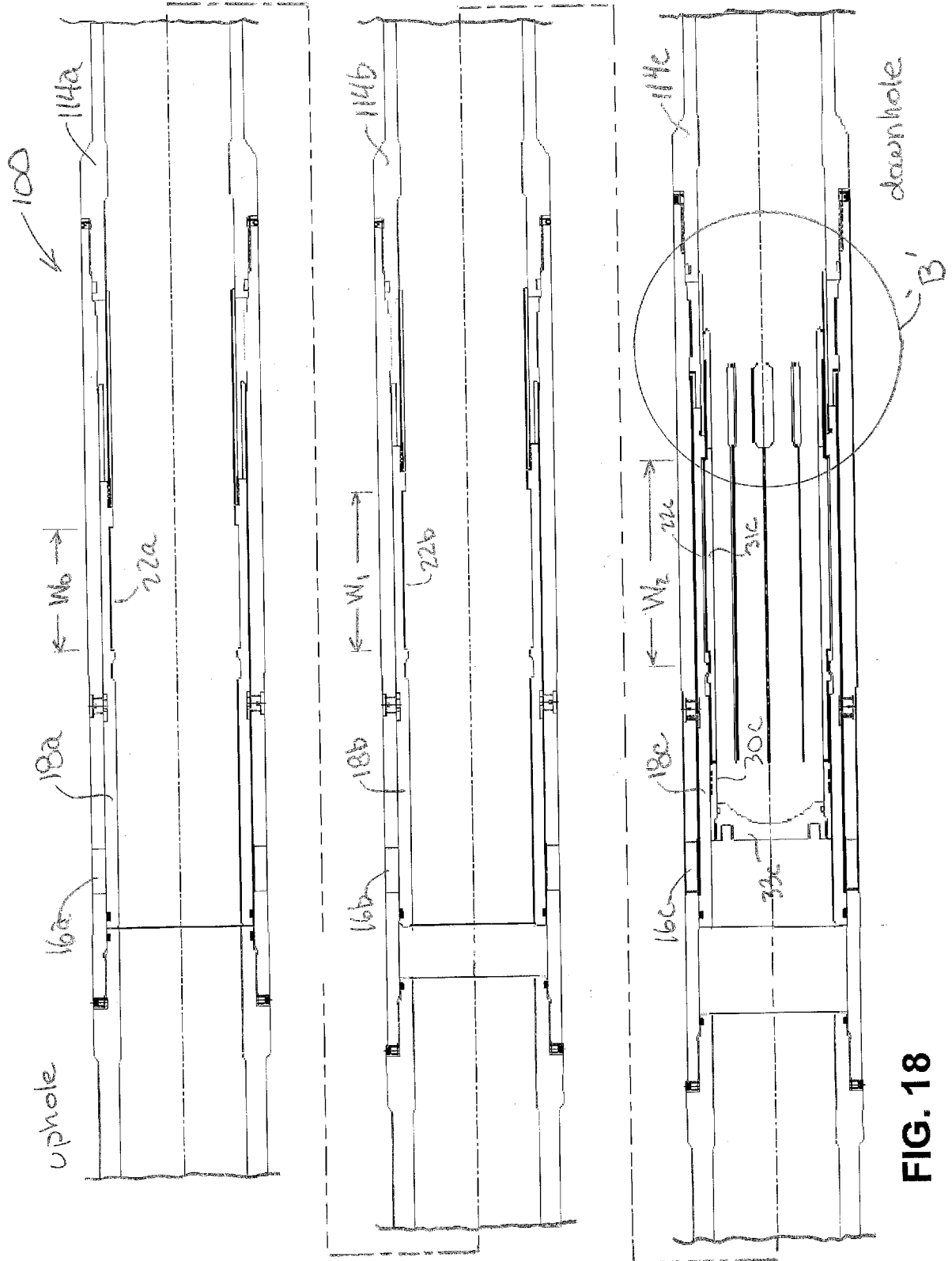

FIG. 18

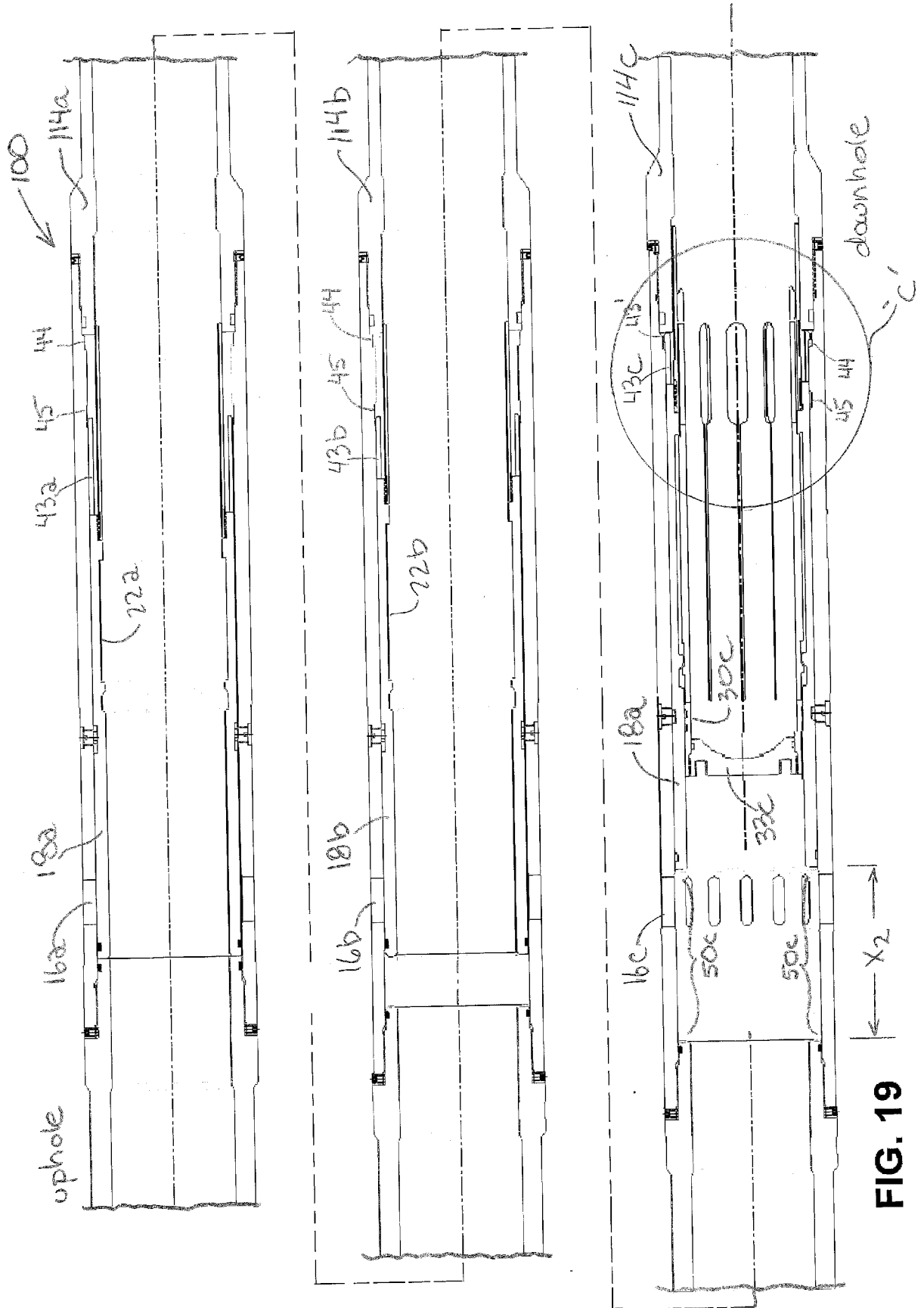

FIG. 19

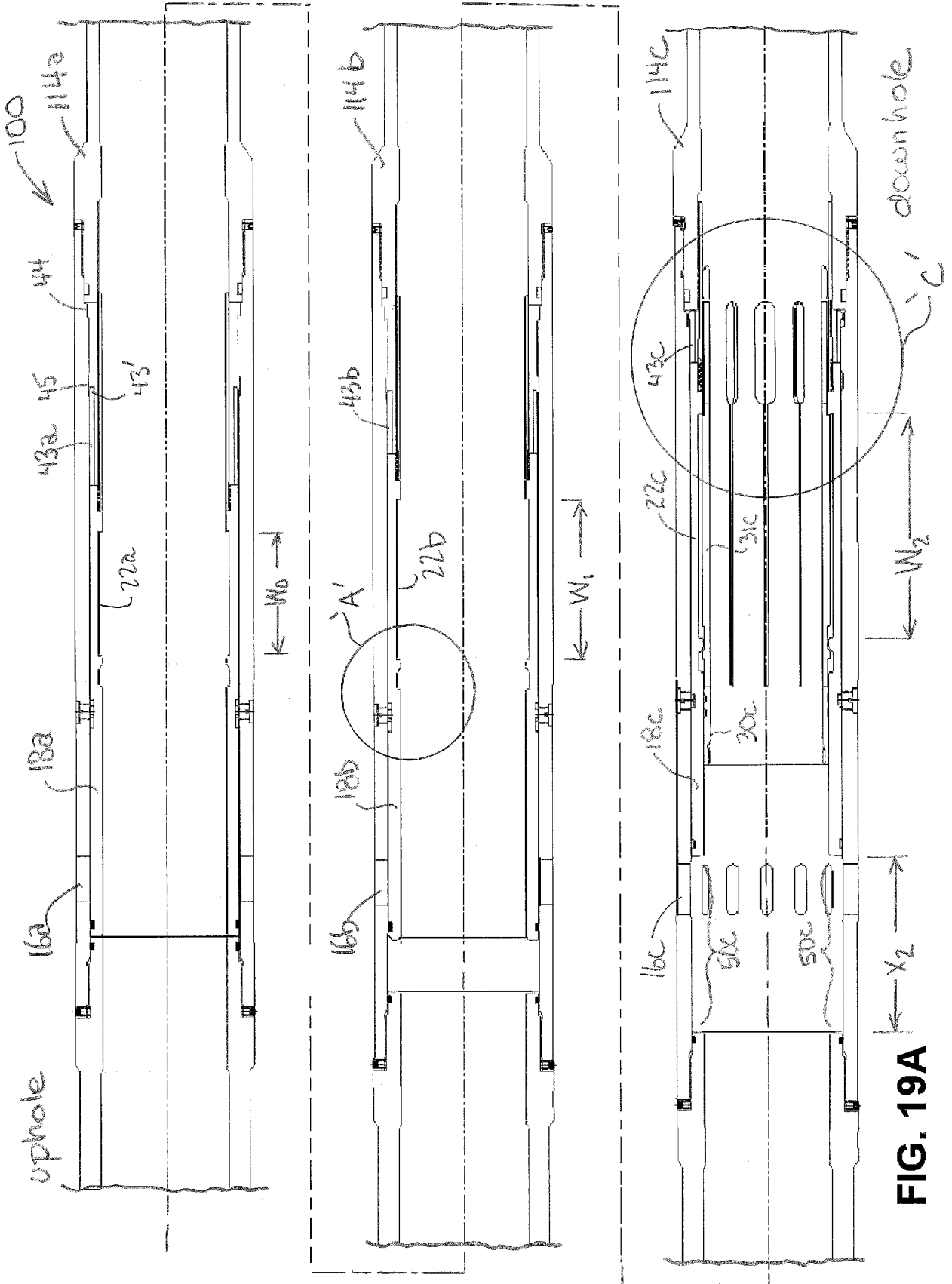

FIG. 19A

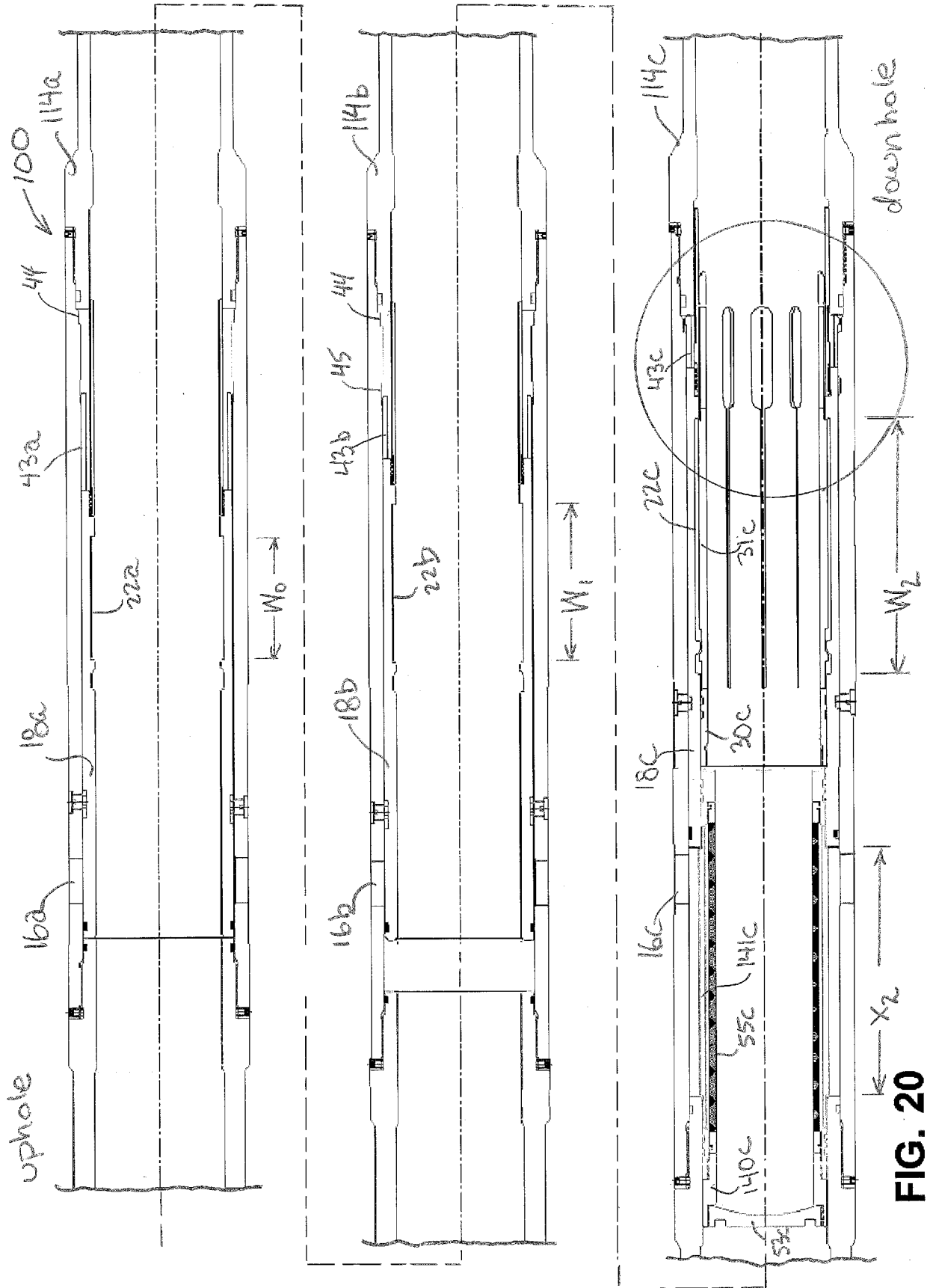

FIG. 20

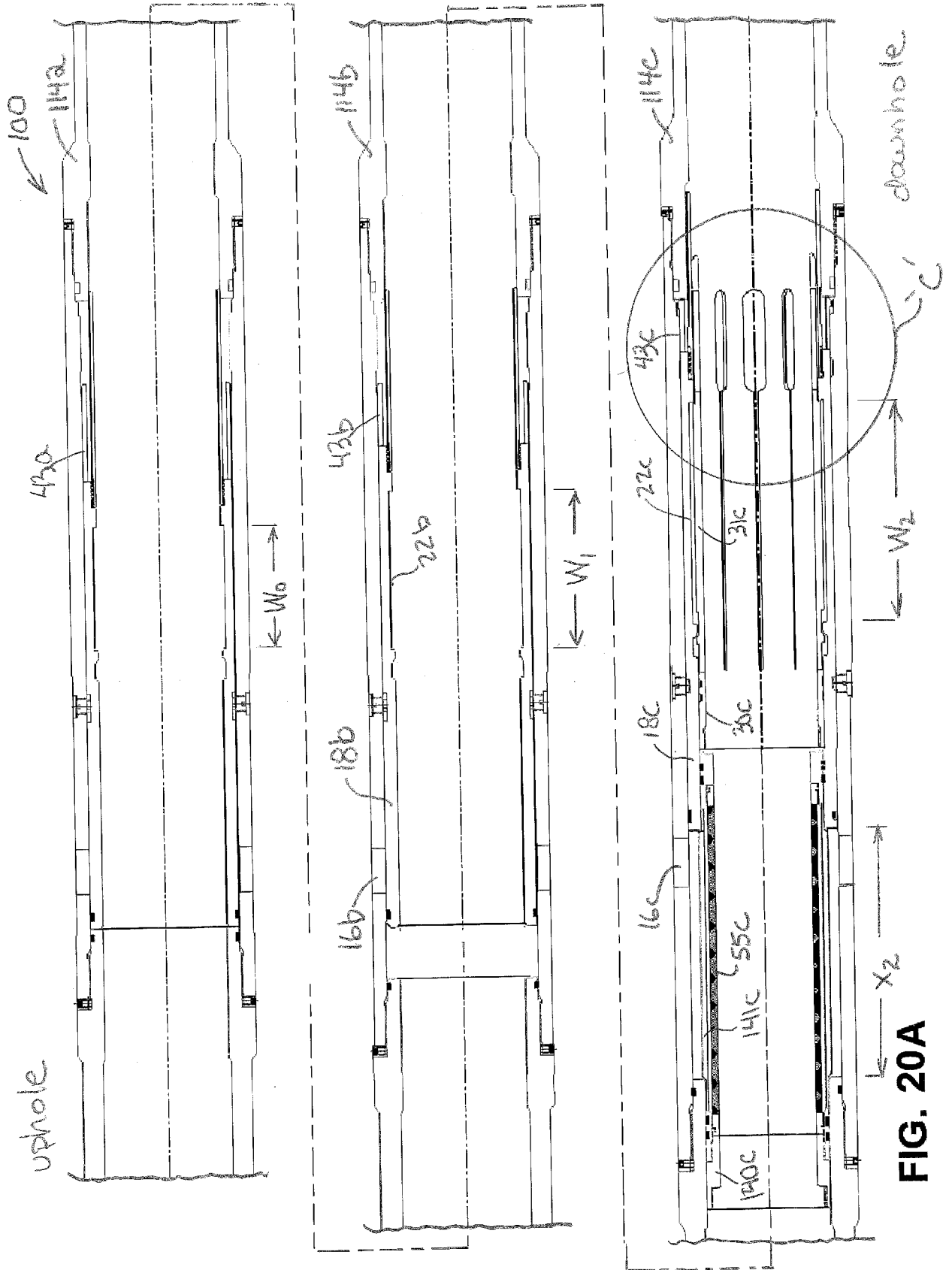

FIG. 20A

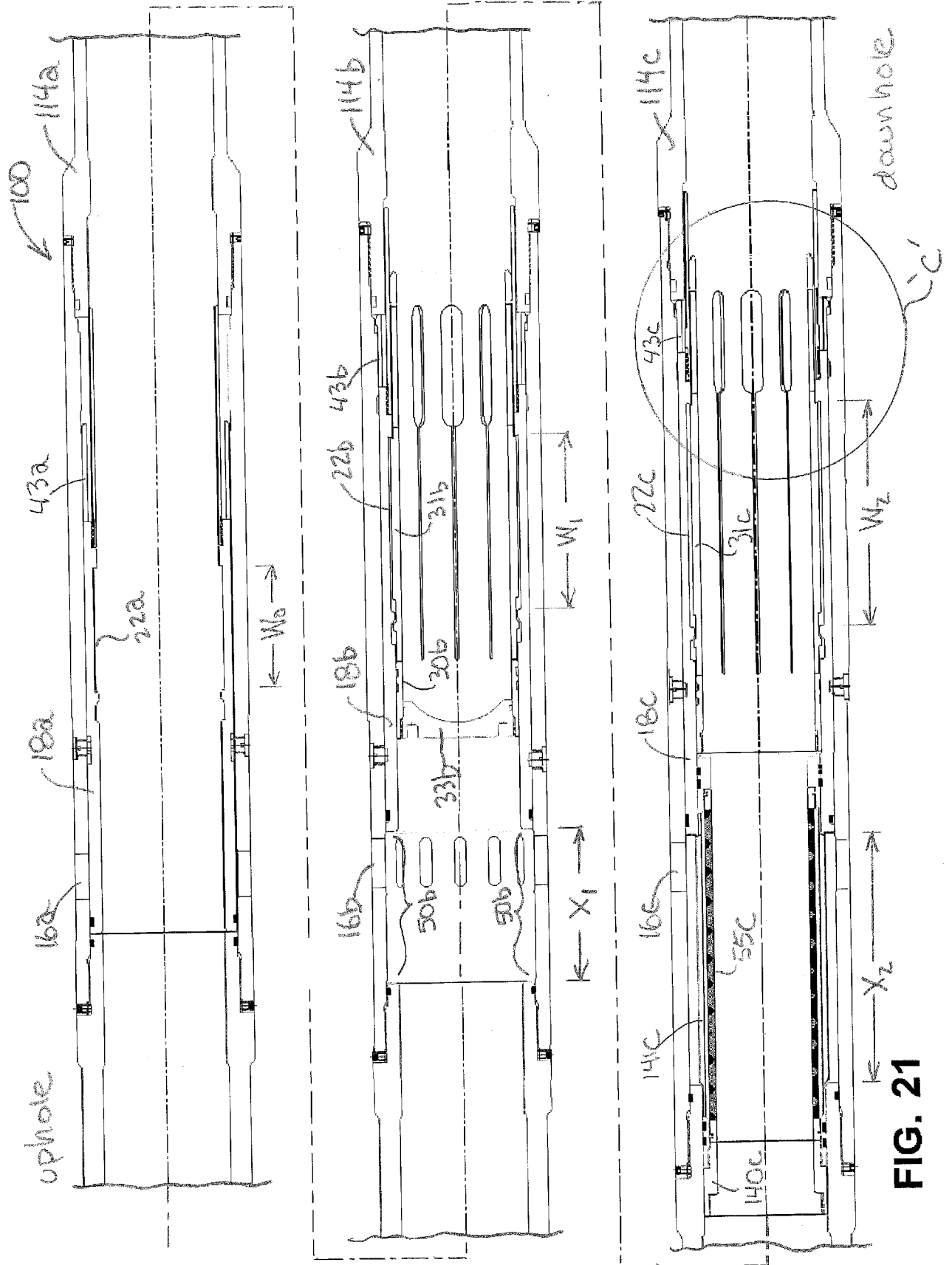

FIG. 21

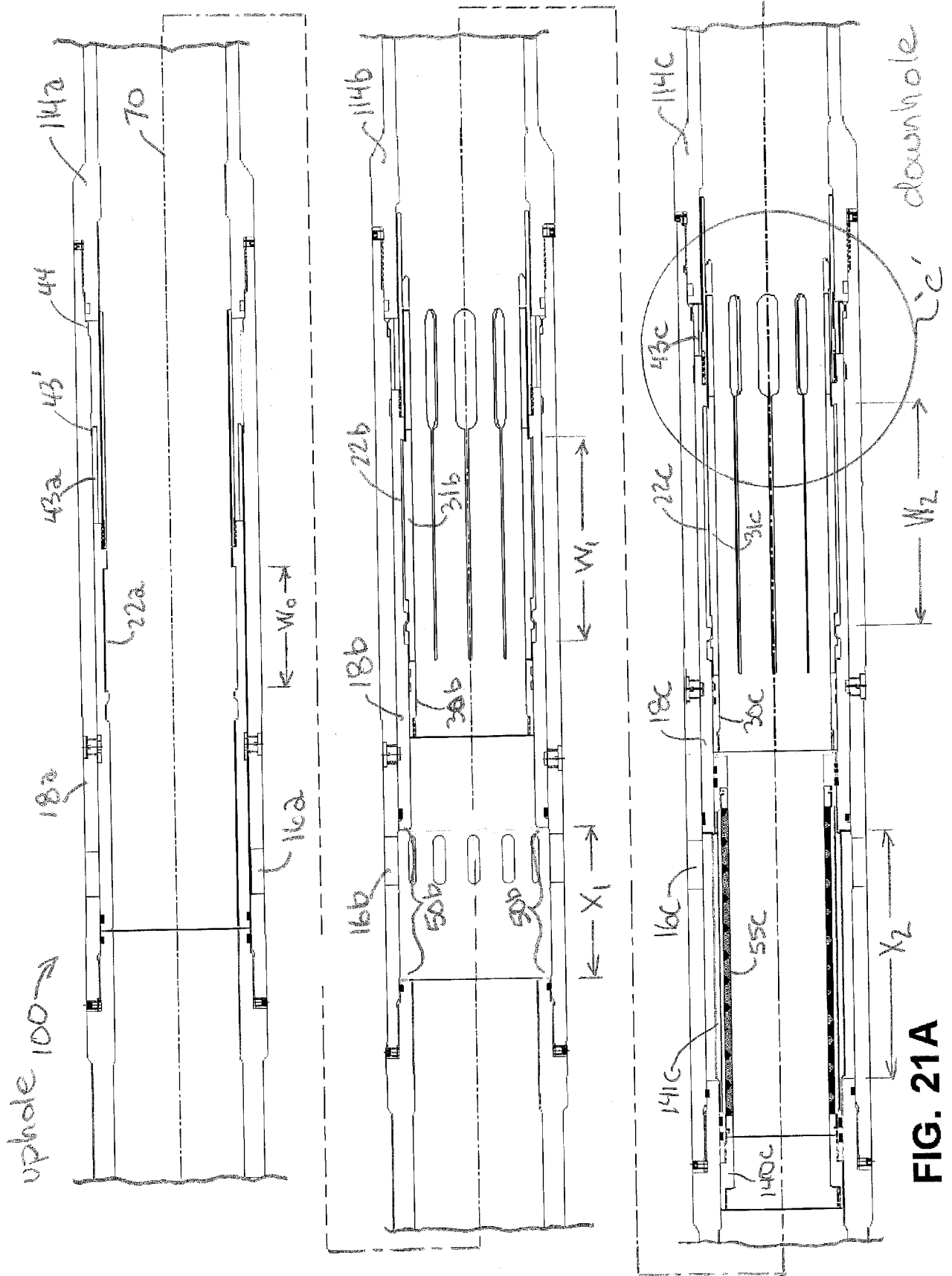

FIG. 21A

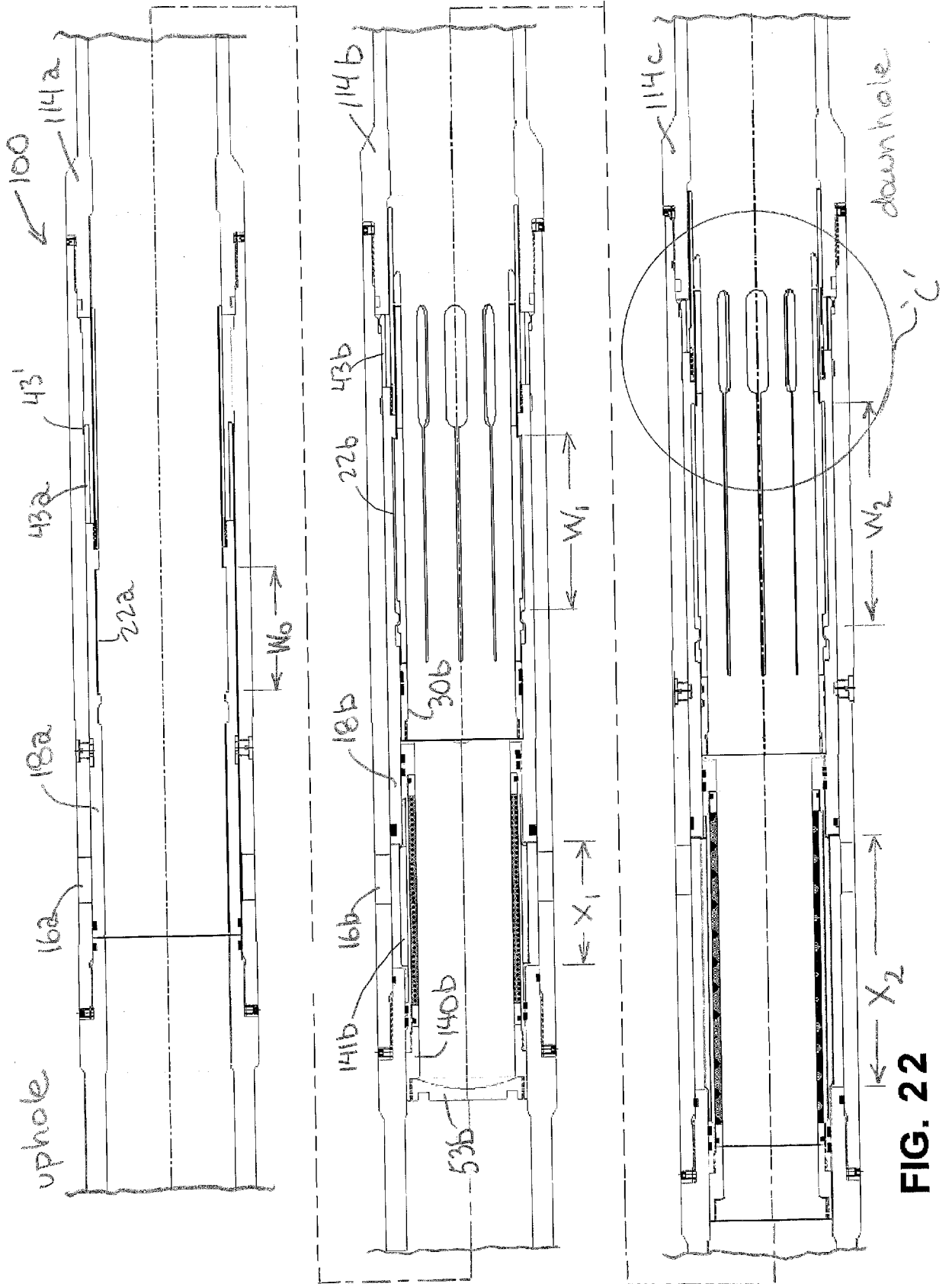

FIG. 22

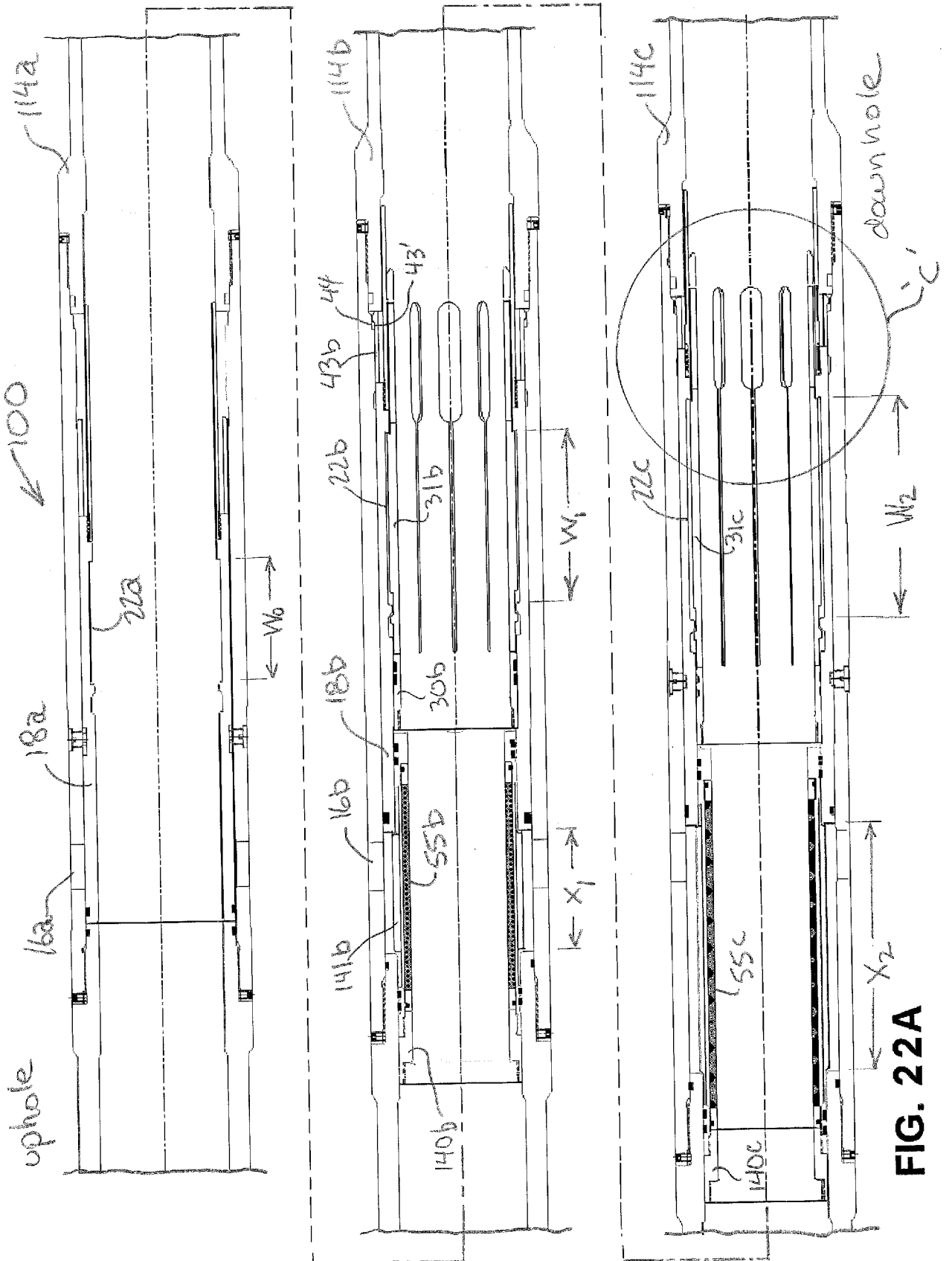

FIG. 22A

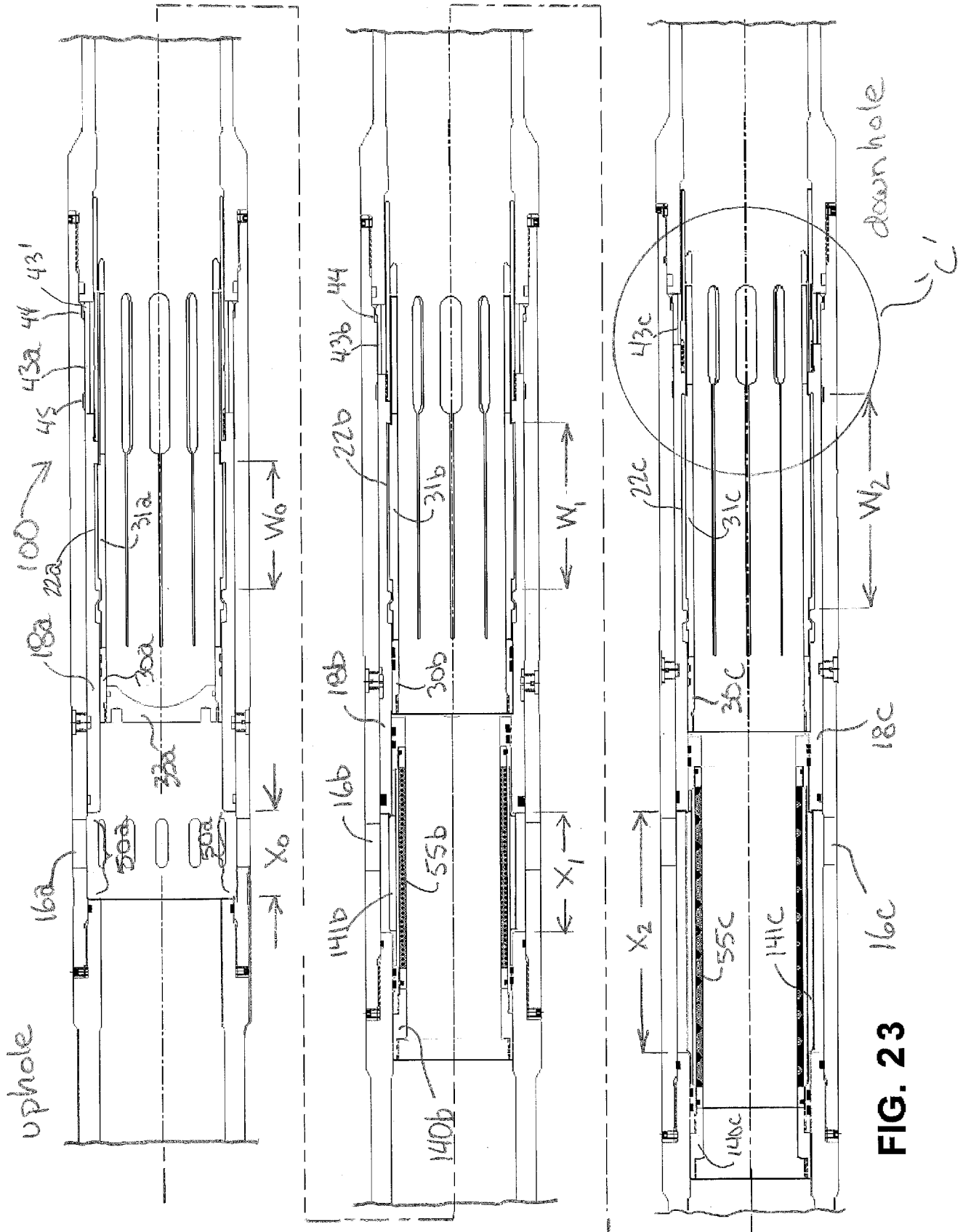

FIG. 23

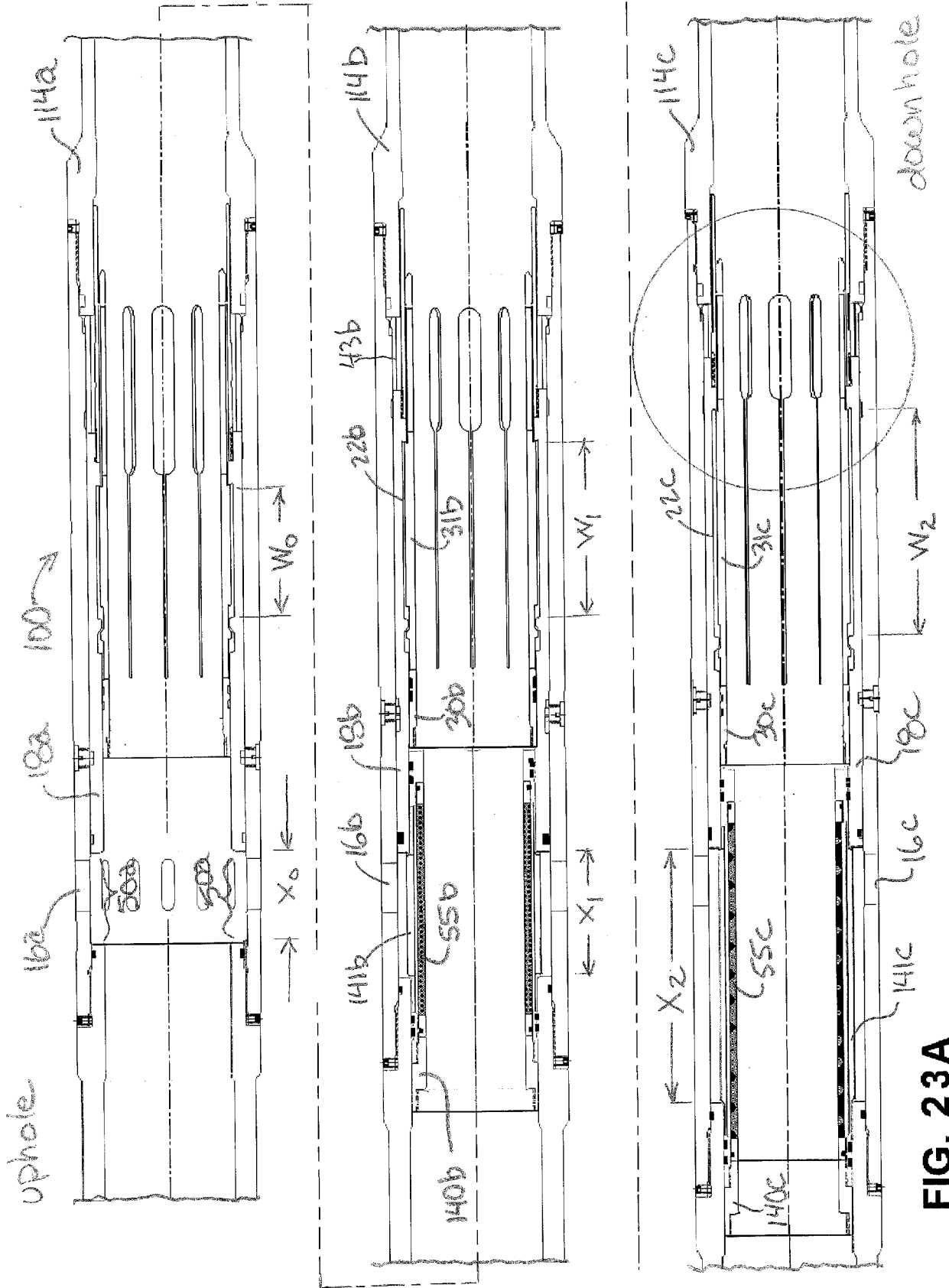

FIG. 23A

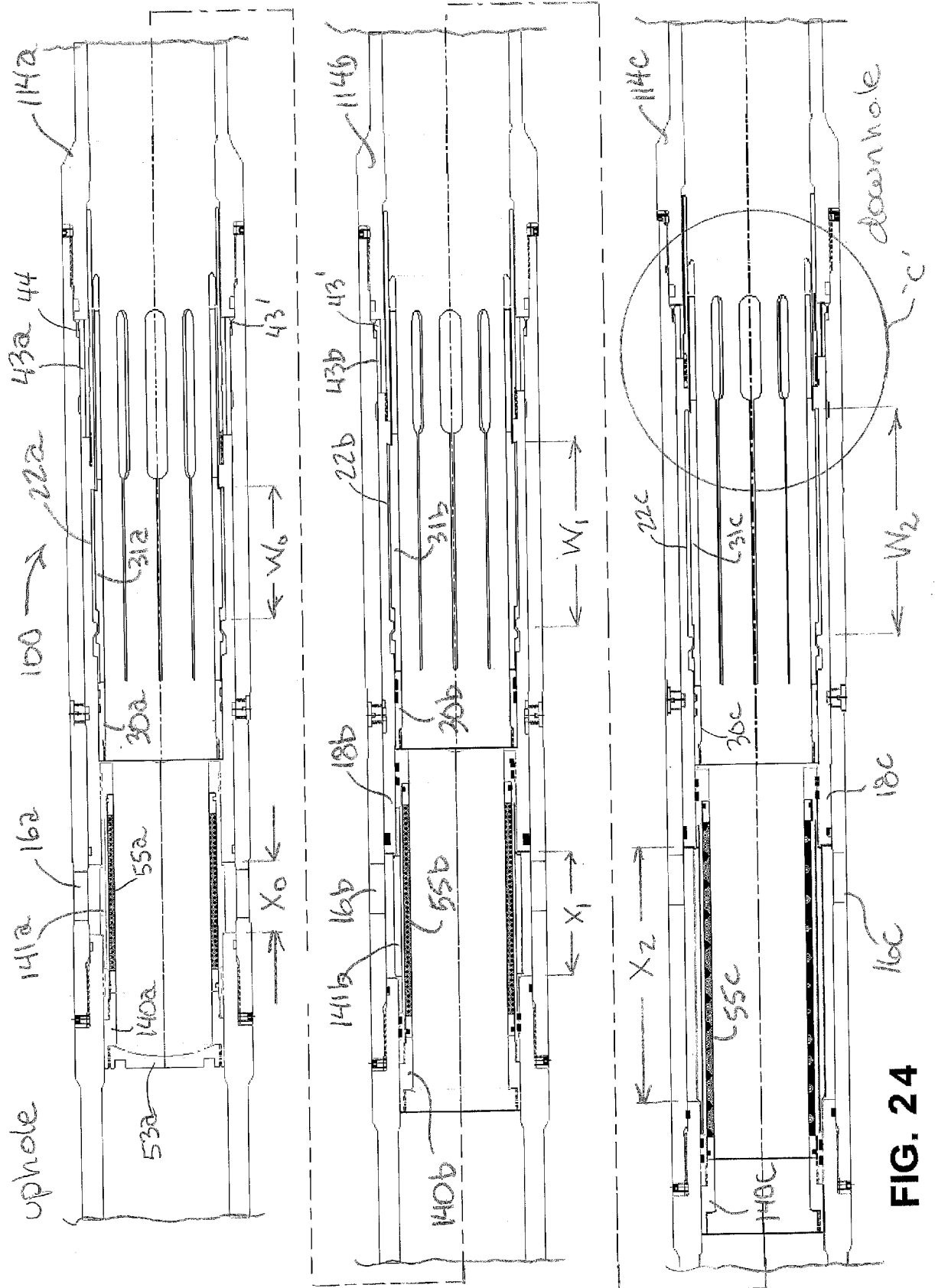

FIG. 24

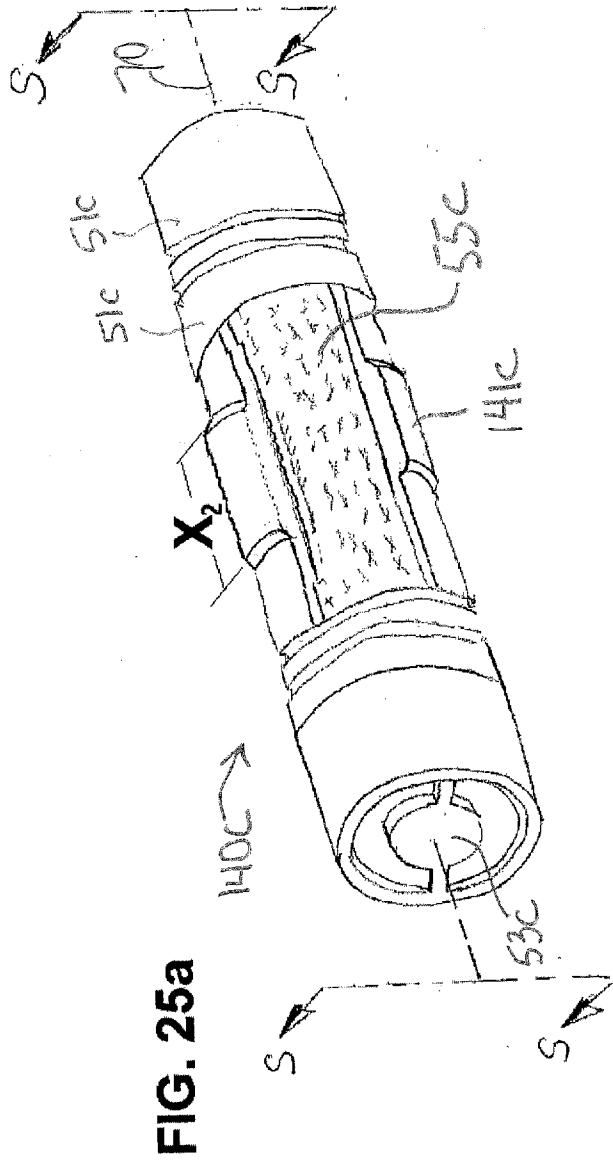

FIG. 25a

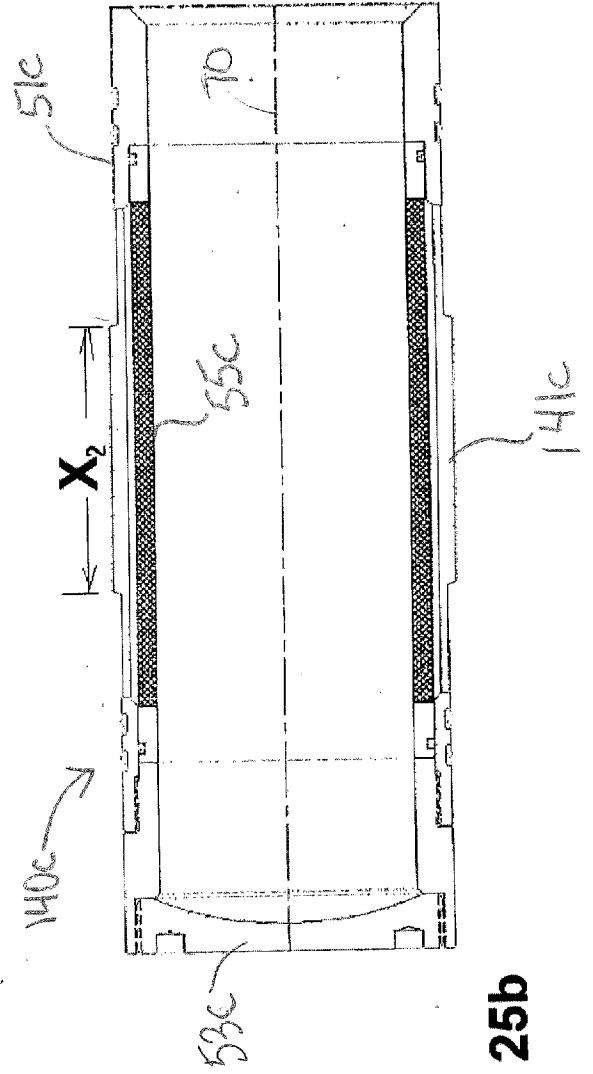
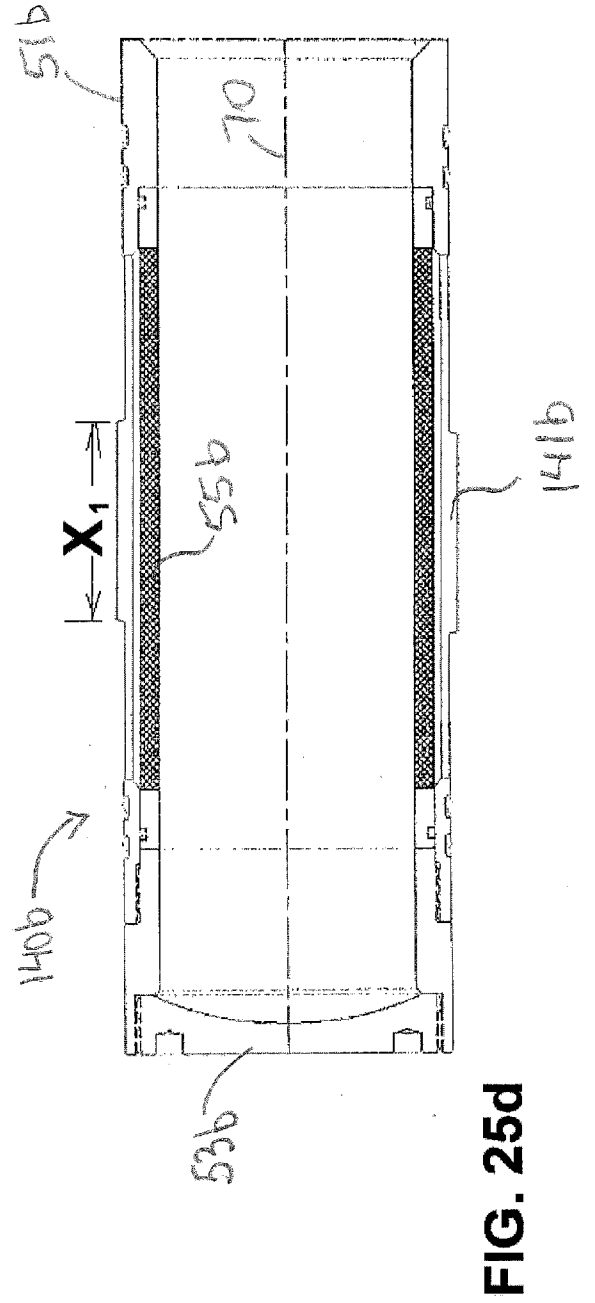
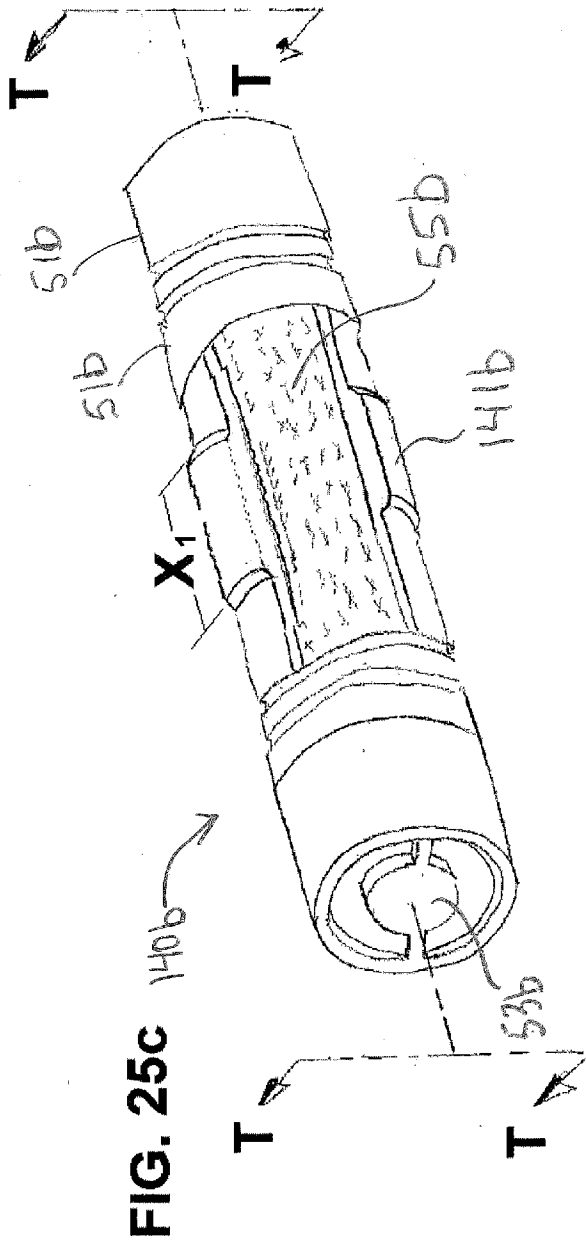
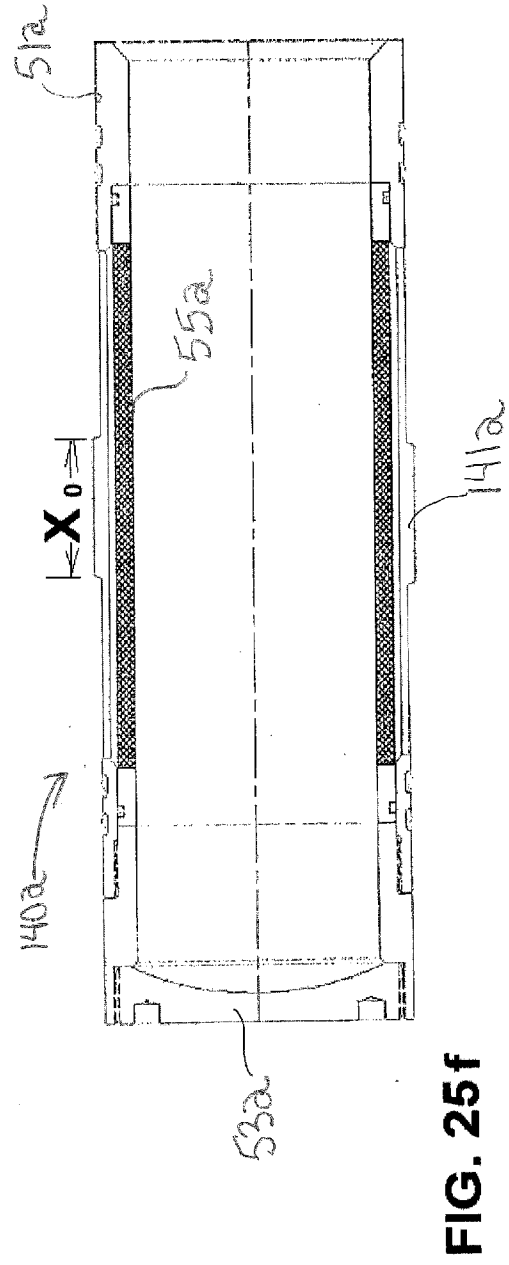
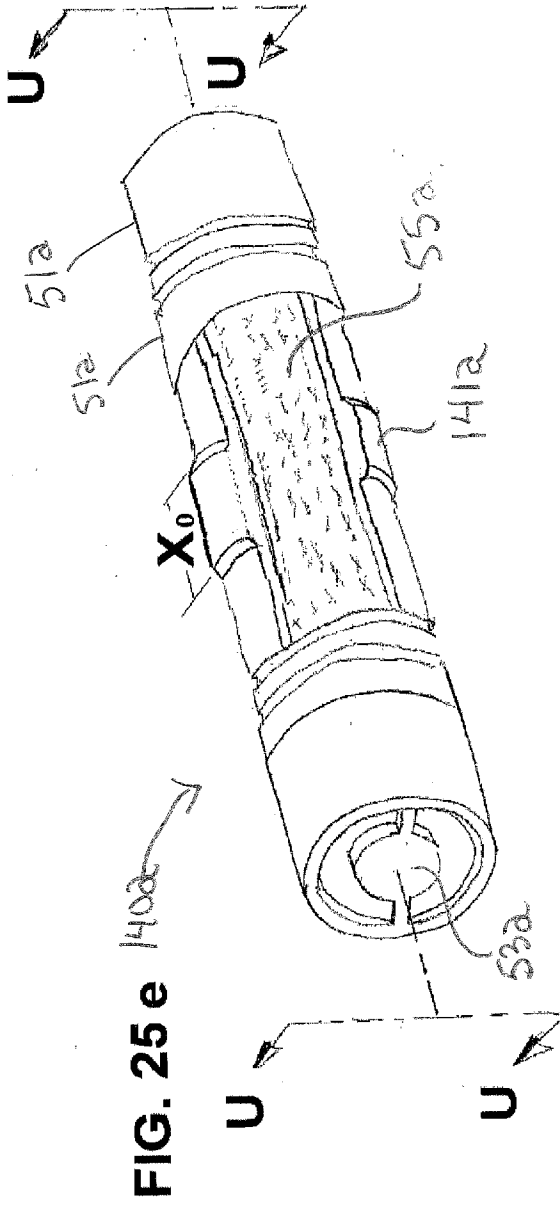

FIG. 25b





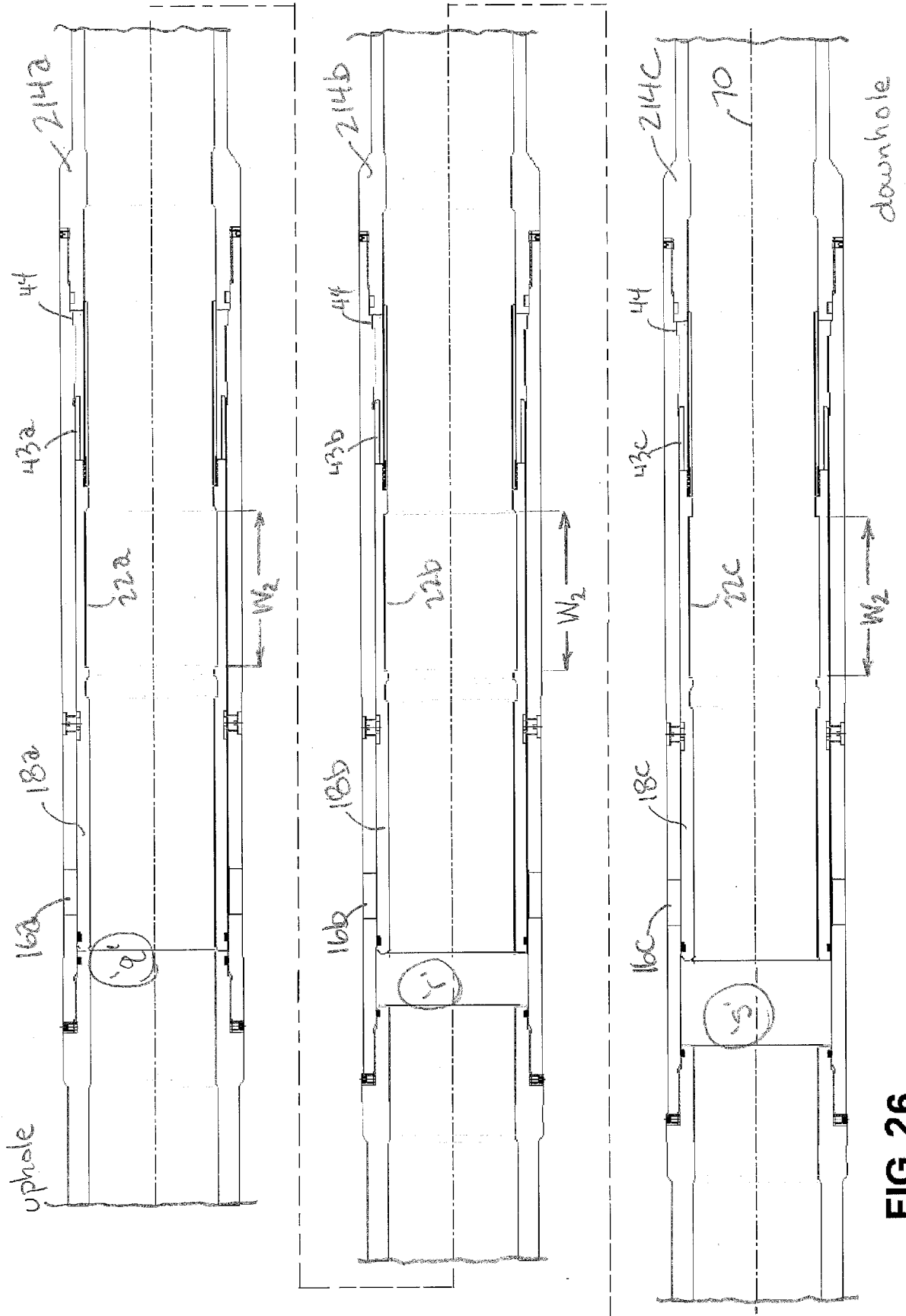

FIG. 26

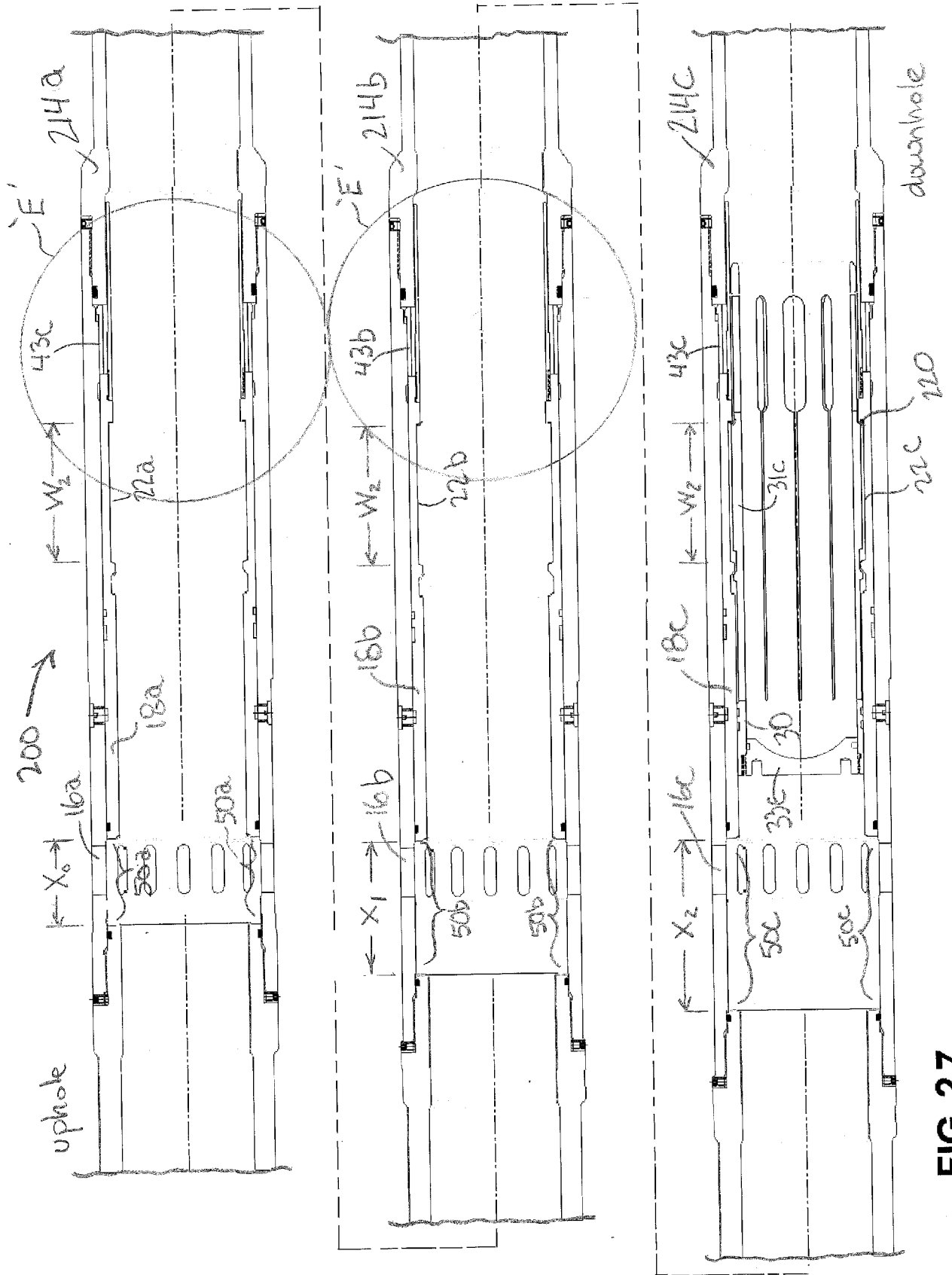

FIG. 27

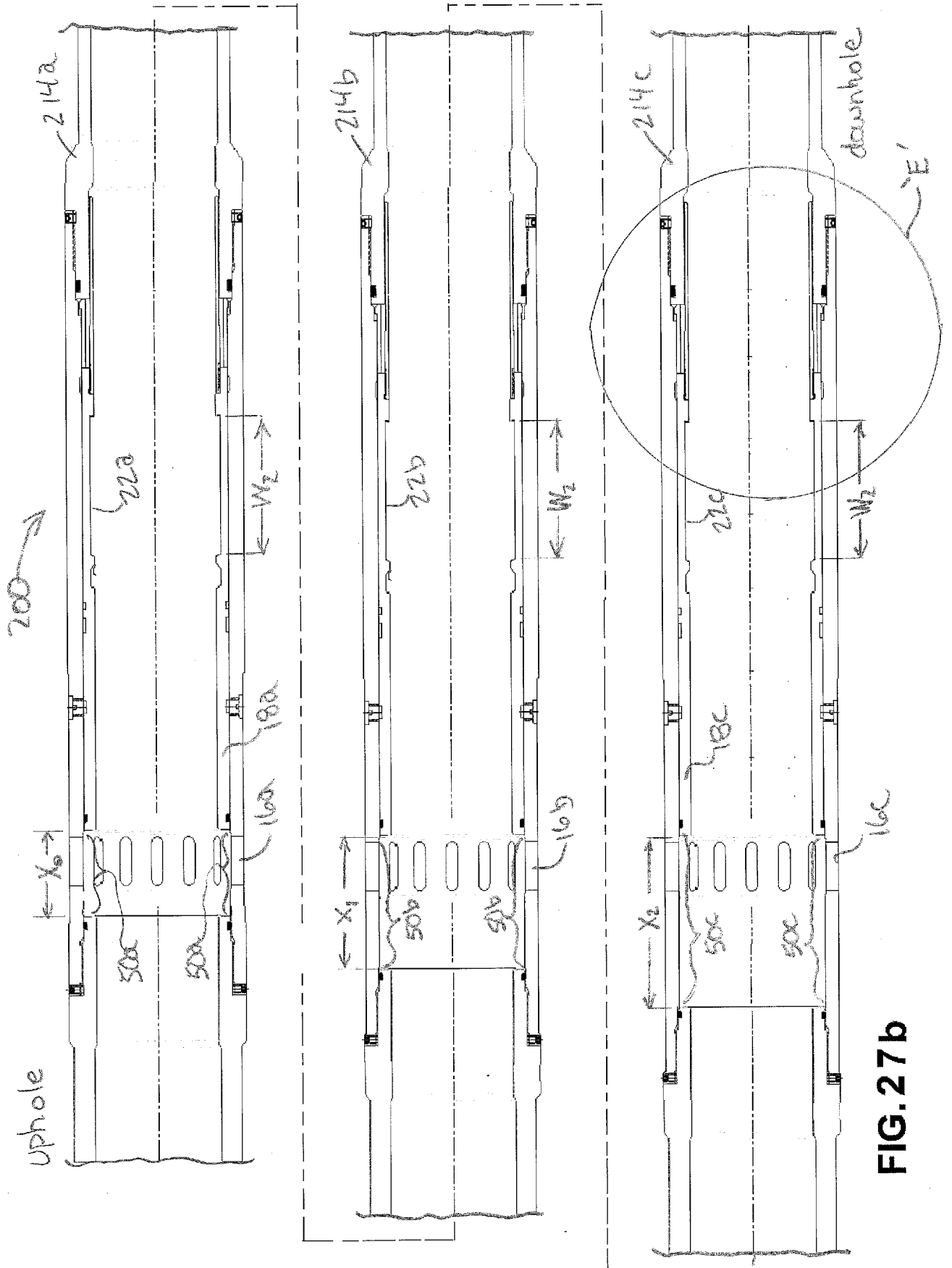

FIG. 27b

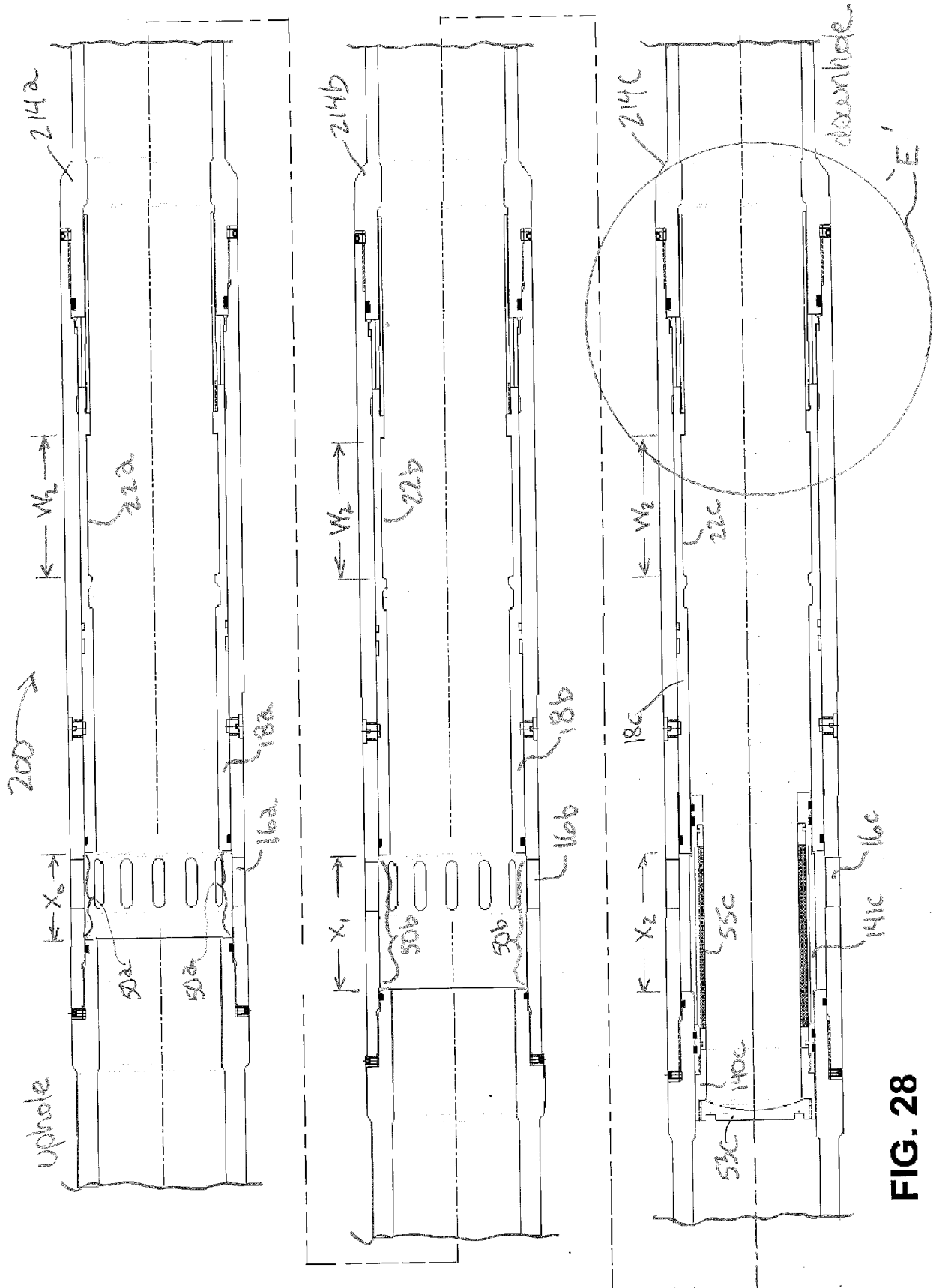

FIG. 28

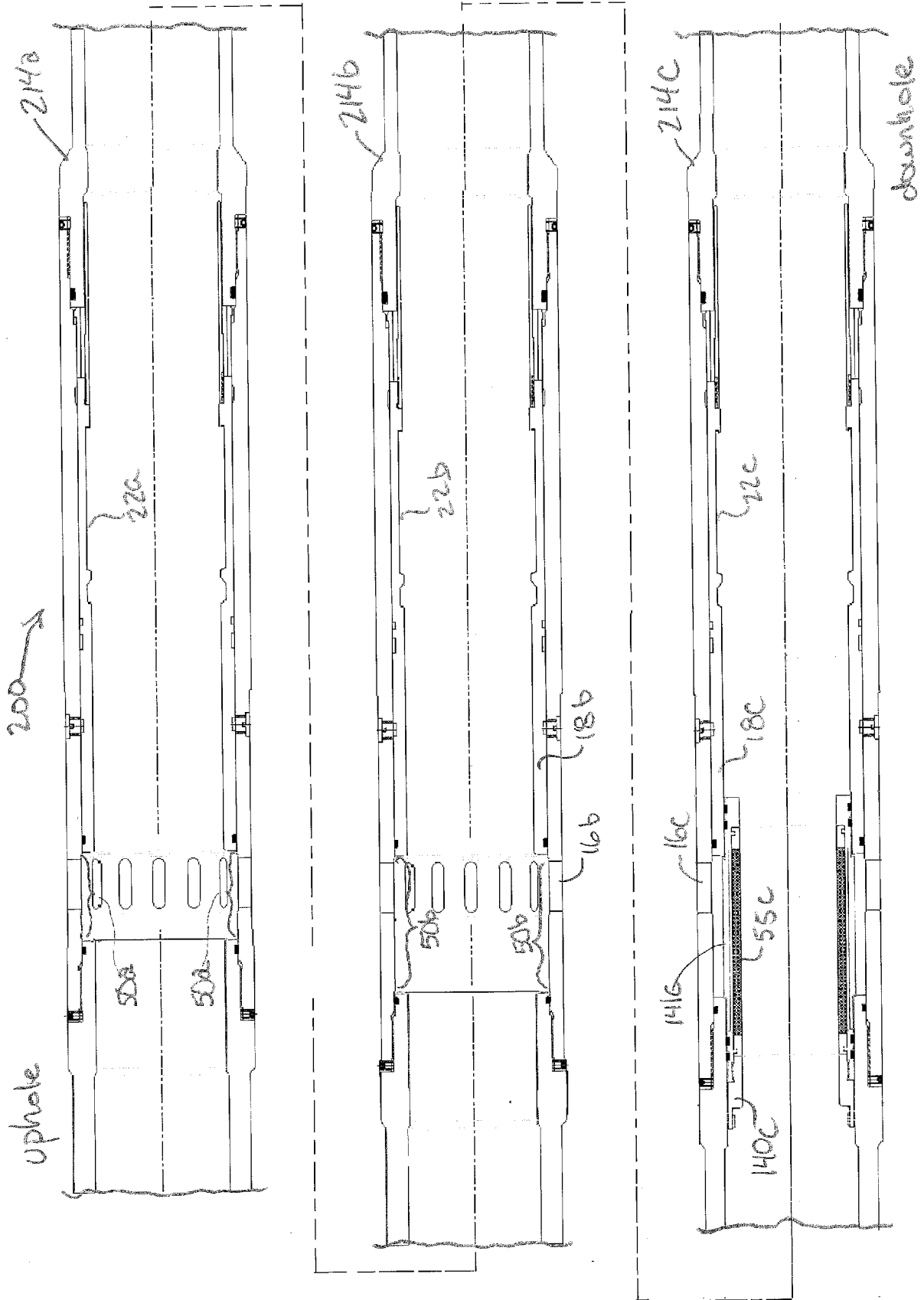

FIG. 28a

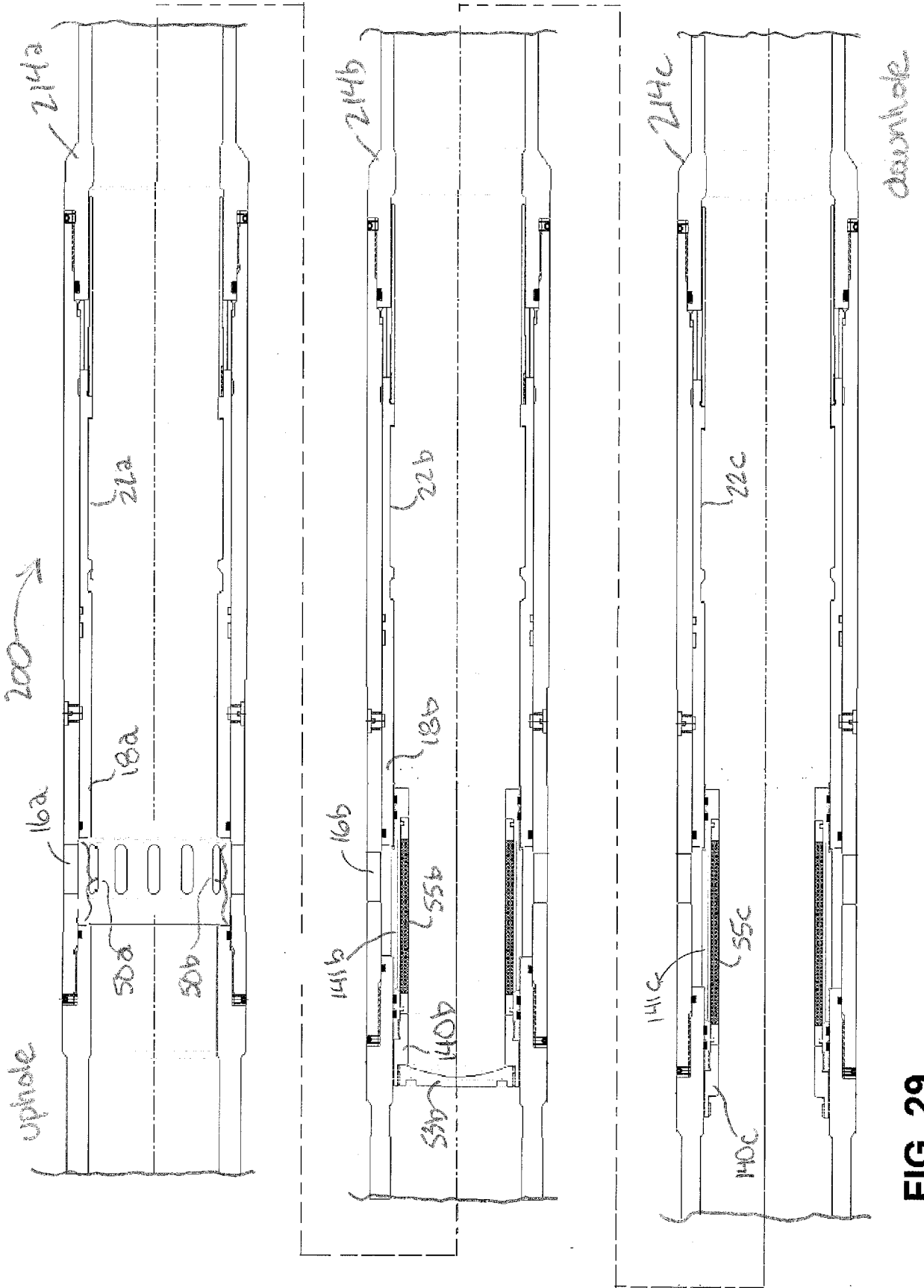

FIG. 29

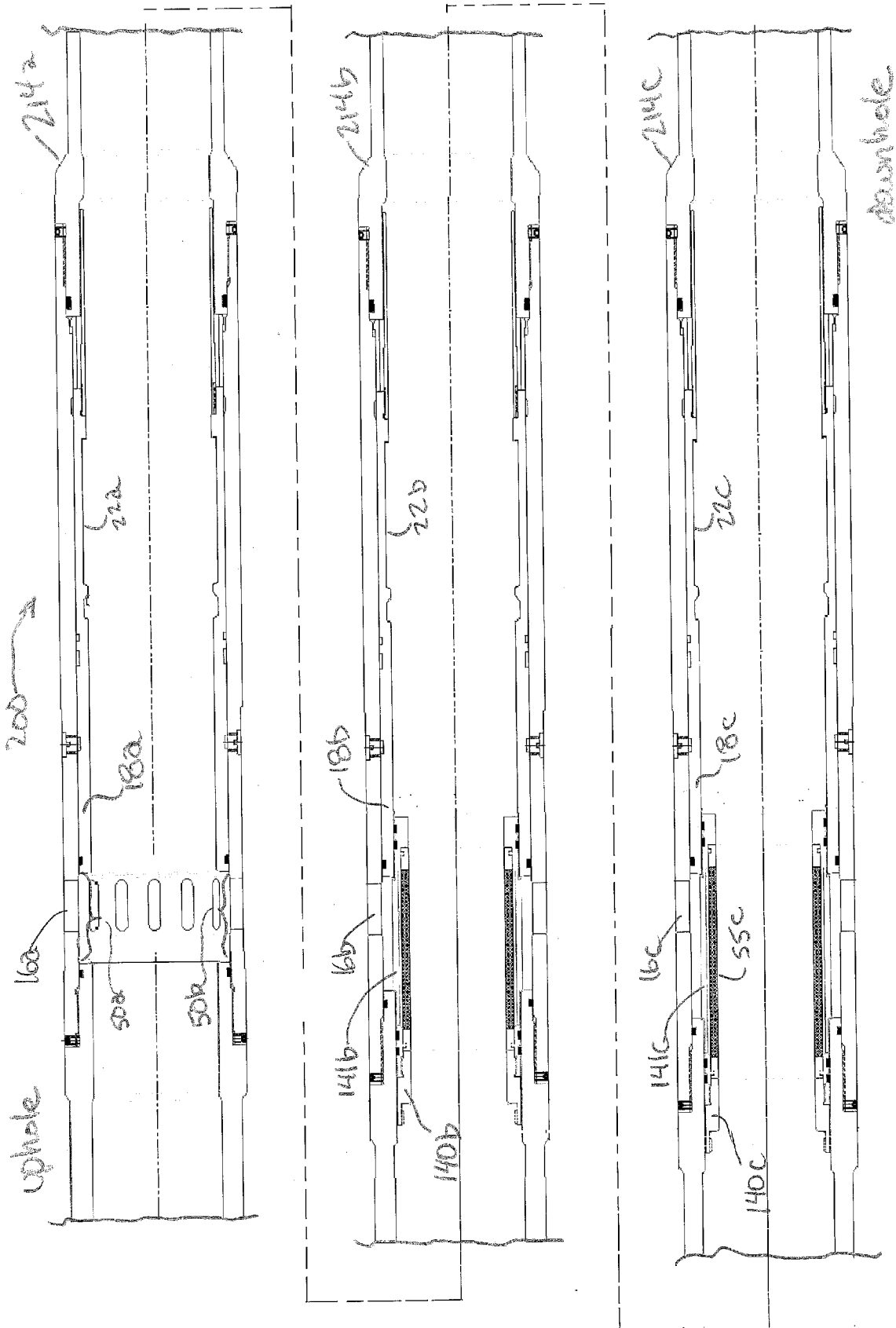

FIG. 29 a

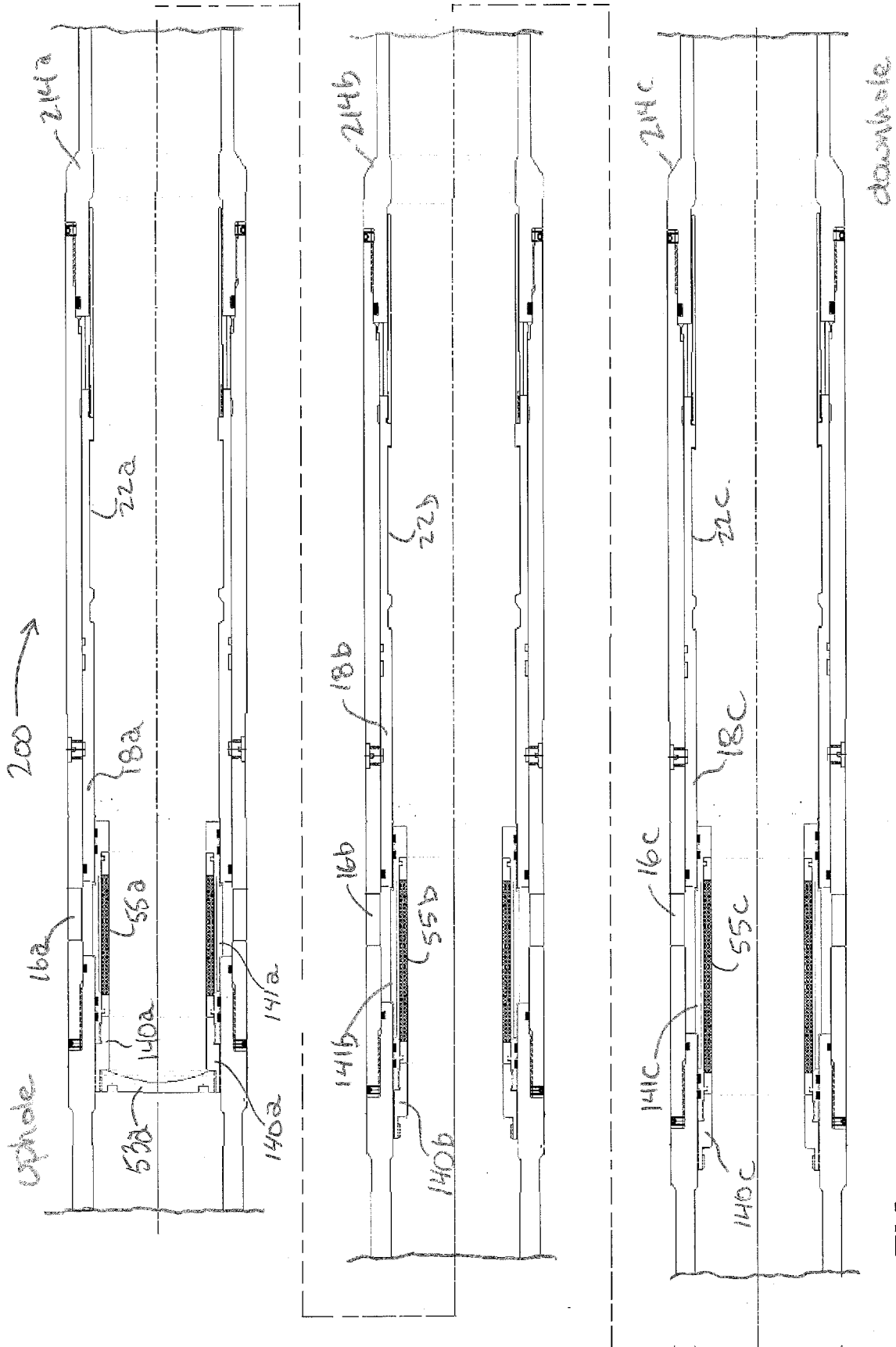

FIG. 30

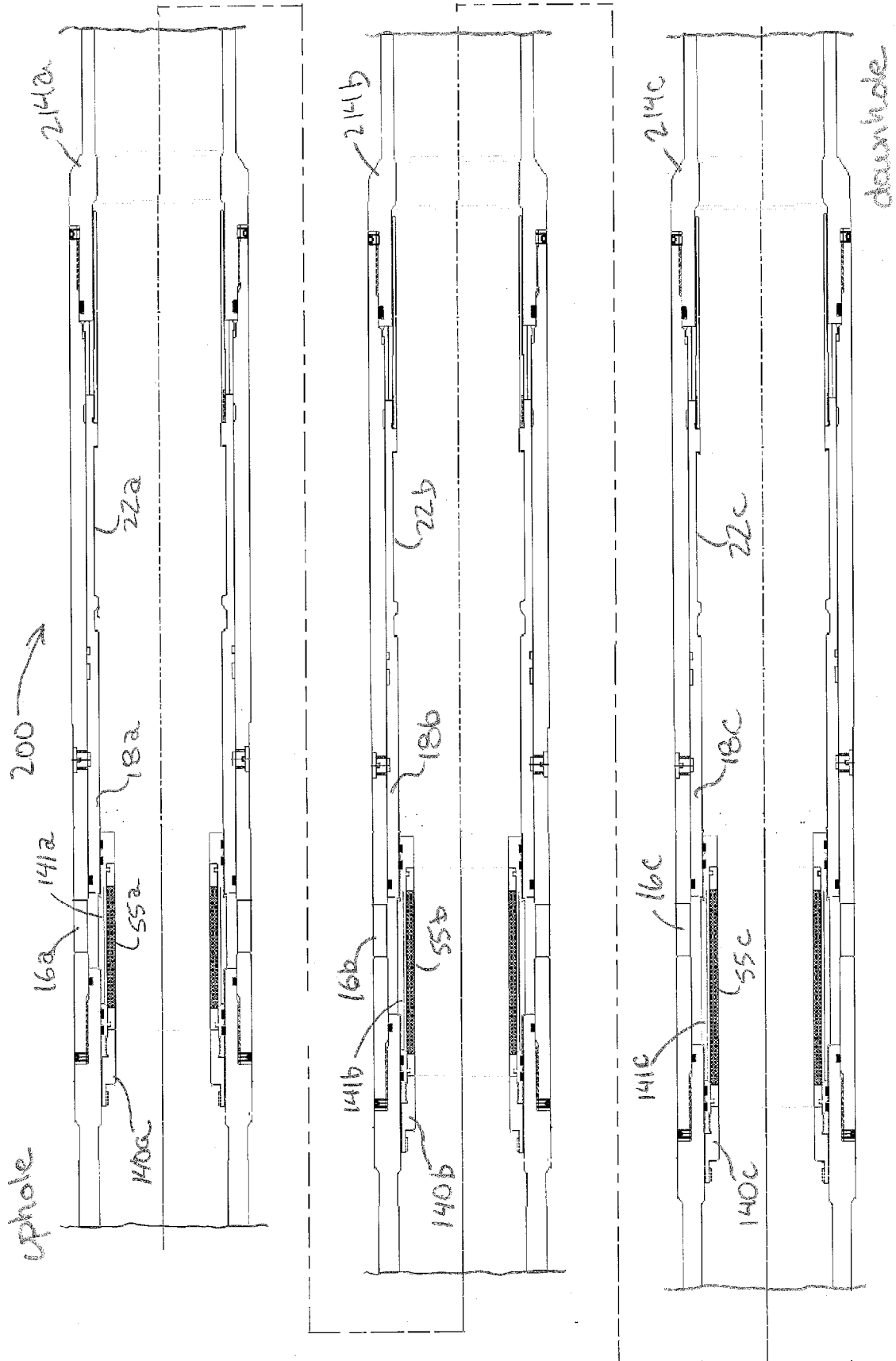

FIG. 30a

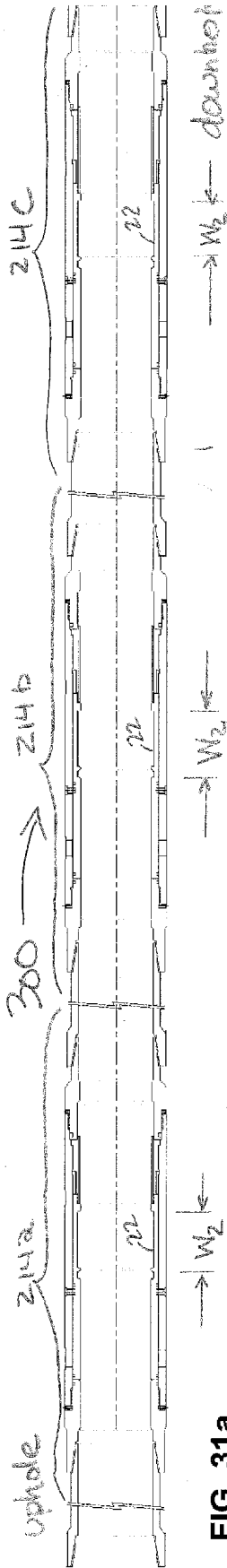

FIG. 31a

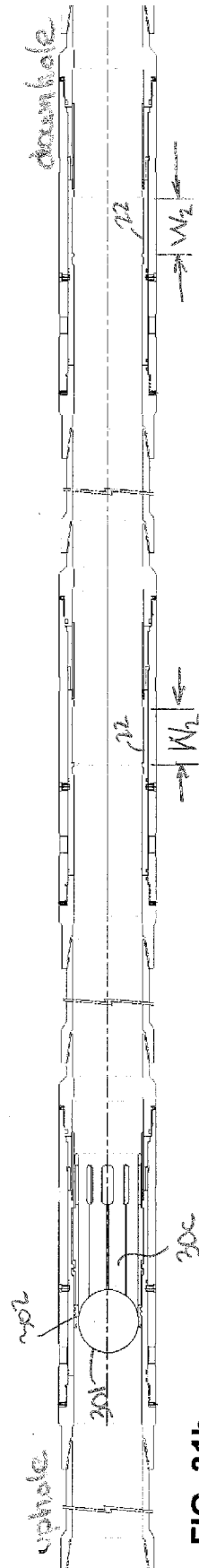

FIG. 31b

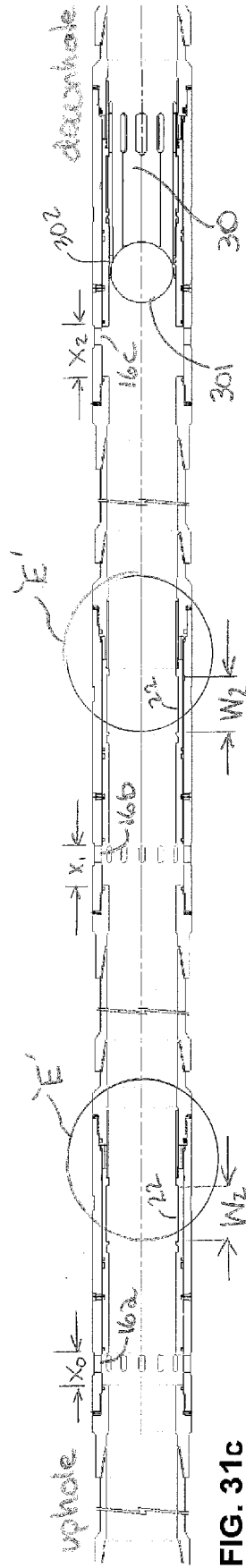

FIG. 31c

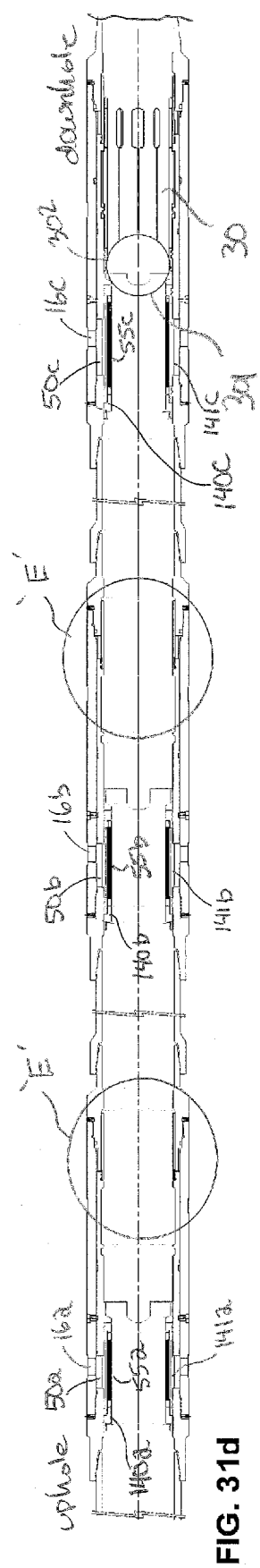

FIG. 31d

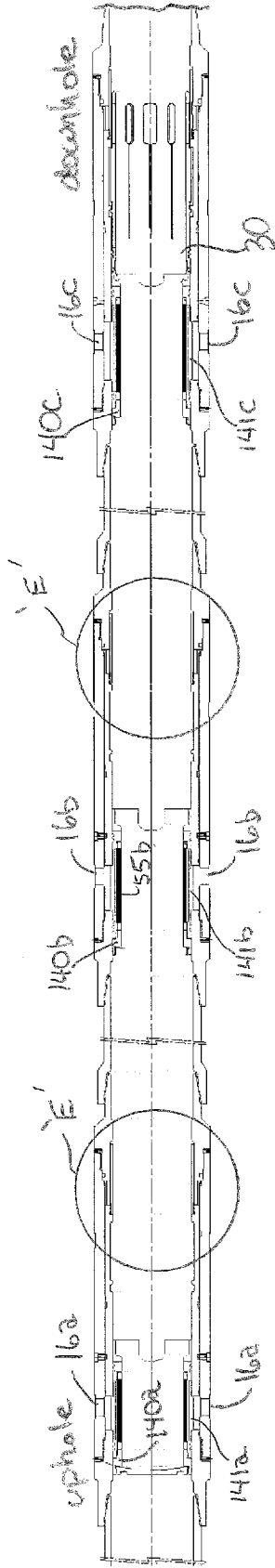

FIG. 31e

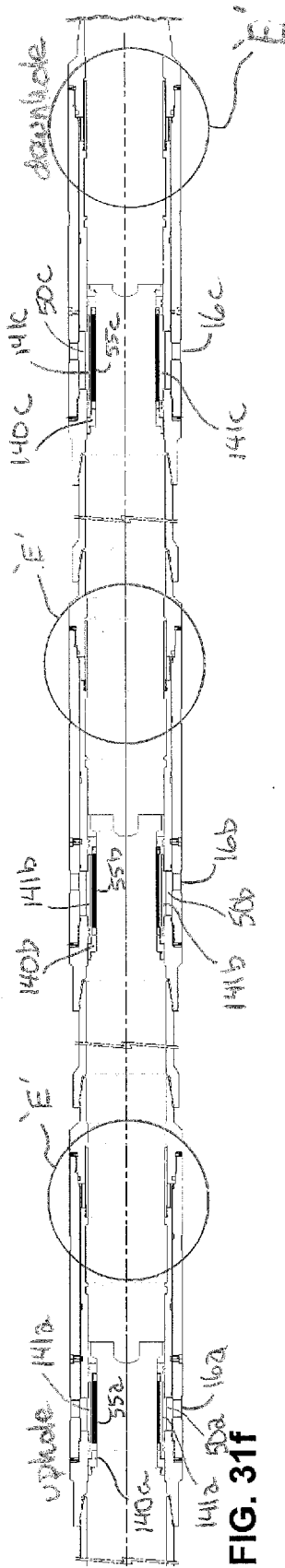
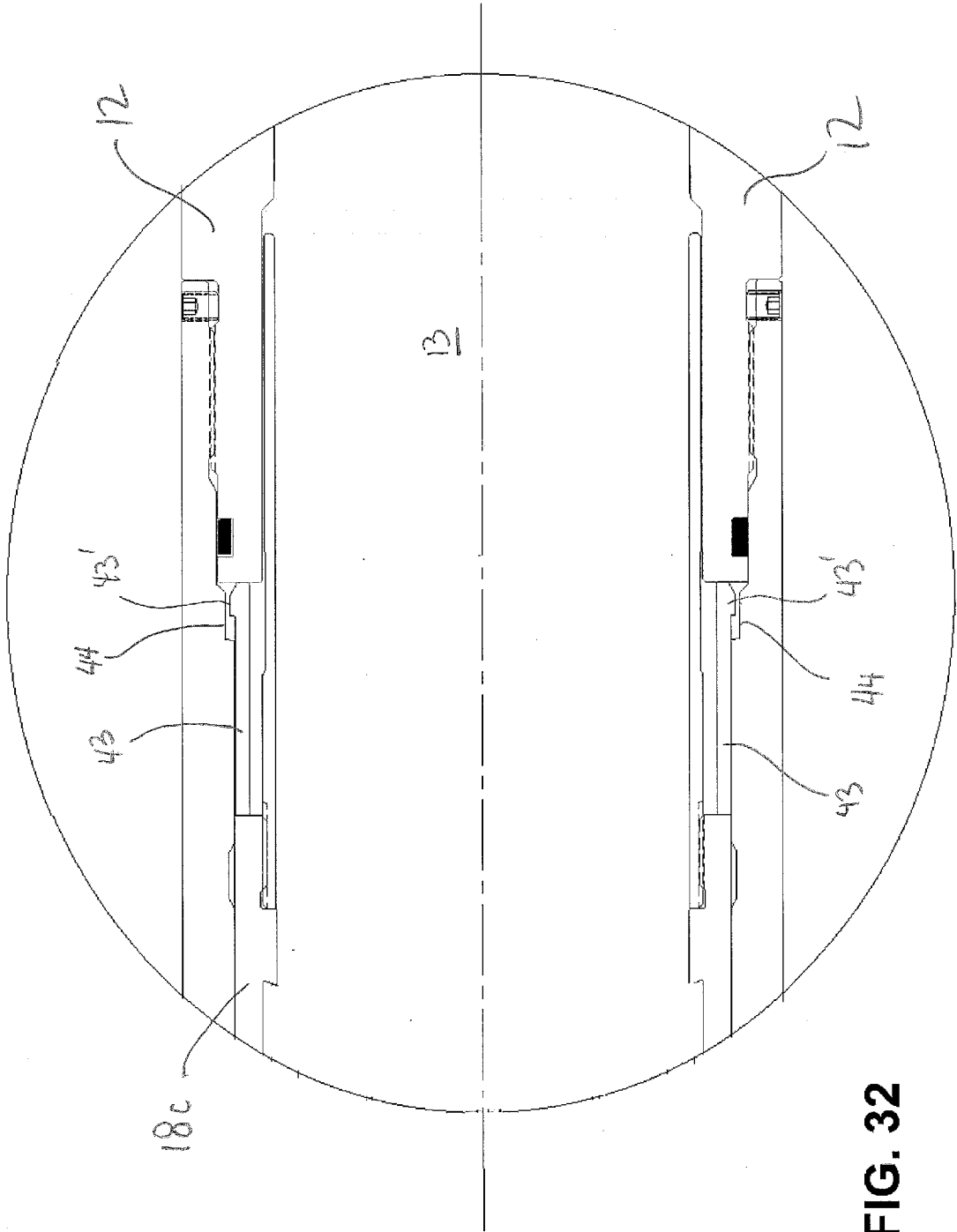

FIG. 31f



INTERNATIONAL SEARCH REPORT

International application No.

PCT/CA2017/050650

A. CLASSIFICATION OF SUBJECT MATTER
 IPC: *E21B 43/10* (2006.01), *E21B 43/08* (2006.01), *E21B 43/26* (2006.01)

According to International Patent Classification (IPC) or to both national classification and IPC

B. FIELDS SEARCHED

Minimum documentation searched (classification system followed by classification symbols)
 IPC: *E21B 43/10* (2006.01), *E21B 43/08* (2006.01), *E21B 43/26* (2006.01)

Documentation searched other than minimum documentation to the extent that such documents are included in the fields searched

Electronic database(s) consulted during the international search (name of database(s) and, where practicable, search terms used)
 QUESTEL-ORBIT (FAMPAT database)

C. DOCUMENTS CONSIDERED TO BE RELEVANT

Category*	Citation of document, with indication, where appropriate, of the relevant passages	Relevant to claim No.
A	CA2904470 A1 (NORDHEIMER) 18 November 2015 (18-11-2015) - refer to abstract; claims 1 & 2	1, 14, 24 & 32
A	CA2867207 A1 (NORDHEIMER) 16 December 2014 (16-12-2014) - refer to entire document	1, 14, 24 & 32
A	US2014083714 A1 (GRIGSBY) 27 March 2014 (27-03-2014) - refer to entire document	1, 14, 24 & 32
A	US2014083682 A1 (GRIGSBY et al.) 27 March 2014 (27-03-2014) - refer to entire document	1, 14, 24 & 32
A	US2008296019 A1 (JOHNSON et al.) 04 December 2008 (04-12-2008) - refer to entire document	1, 14, 24 & 32

Further documents are listed in the continuation of Box C.

See patent family annex.

* "A" "E" "L" "O" "P"	Special categories of cited documents: document defining the general state of the art which is not considered to be of particular relevance earlier application or patent but published on or after the international filing date document which may throw doubts on priority claim(s) or which is cited to establish the publication date of another citation or other special reason (as specified) document referring to an oral disclosure, use, exhibition or other means document published prior to the international filing date but later than the priority date claimed	"T" "X" "Y" "&"	later document published after the international filing date or priority date and not in conflict with the application but cited to understand the principle or theory underlying the invention document of particular relevance; the claimed invention cannot be considered novel or cannot be considered to involve an inventive step when the document is taken alone document of particular relevance; the claimed invention cannot be considered to involve an inventive step when the document is combined with one or more other such documents, such combination being obvious to a person skilled in the art document member of the same patent family
--------------------------------------	--	--------------------------	--

Date of the actual completion of the international search
 26 January 2018 (26-01-2018)

Date of mailing of the international search report
 31 January 2018 (31-01-2018)

Name and mailing address of the ISA/CA
 Canadian Intellectual Property Office
 Place du Portage I, C114 - 1st Floor, Box PCT
 50 Victoria Street
 Gatineau, Quebec K1A 0C9
 Facsimile No.: 819-953-2476

Authorized officer

Ishtiaque Ibne Rashid (819) 639-7889

INTERNATIONAL SEARCH REPORT
Information on patent family members

International application No.
PCT/CA2017/050650

Patent Document Cited in Search Report	Publication Date	Patent Family Member(s)	Publication Date
CA2904470A1	18 November 2015 (18-11-2015)	CA2904470A1	18 November 2015 (18-11-2015)
		AU2015327728A1	16 March 2017 (16-03-2017)
		AU2016253992A1	13 April 2017 (13-04-2017)
		CA2867207A1	16 December 2014 (16-12-2014)
		CA2867207C	09 February 2016 (09-02-2016)
		CA2927850A1	15 July 2016 (15-07-2016)
		CA2927850C	09 May 2017 (09-05-2017)
		CN107429556A	01 December 2017 (01-12-2017)
		MX2017005993A	29 June 2017 (29-06-2017)
		US2016097257A1	07 April 2016 (07-04-2016)
		US9587464B2	07 March 2017 (07-03-2017)
		US2016312580A1	27 October 2016 (27-10-2016)
		US9840890B2	12 December 2017 (12-12-2017)
		US2016312581A1	27 October 2016 (27-10-2016)
		US9840892B2	12 December 2017 (12-12-2017)
		WO2016049733A1	07 April 2016 (07-04-2016)
WO2016049751A1	07 April 2016 (07-04-2016)		
WO2016172791A1	03 November 2016 (03-11-2016)		
CA2867207A1	16 December 2014 (16-12-2014)	CA2867207A1	16 December 2014 (16-12-2014)
		CA2867207C	09 February 2016 (09-02-2016)
		AU2015327728A1	16 March 2017 (16-03-2017)
		AU2016253992A1	13 April 2017 (13-04-2017)
		CA2904470A1	18 November 2015 (18-11-2015)
		CA2927850A1	15 July 2016 (15-07-2016)
		CA2927850C	09 May 2017 (09-05-2017)
		CN107429556A	01 December 2017 (01-12-2017)
		MX2017005993A	29 June 2017 (29-06-2017)
		US2016097257A1	07 April 2016 (07-04-2016)
		US9587464B2	07 March 2017 (07-03-2017)
		US2016312580A1	27 October 2016 (27-10-2016)
		US9840890B2	12 December 2017 (12-12-2017)
		US2016312581A1	27 October 2016 (27-10-2016)
		US9840892B2	12 December 2017 (12-12-2017)
		WO2016049733A1	07 April 2016 (07-04-2016)
WO2016049751A1	07 April 2016 (07-04-2016)		
WO2016172791A1	03 November 2016 (03-11-2016)		
US2014083714A1	27 March 2014 (27-03-2014)	US2014083714A1	27 March 2014 (27-03-2014)
		AU2012391065A1	02 April 2015 (02-04-2015)
		EP2900904A1	05 August 2015 (05-08-2015)
		MX2015003816A	14 July 2015 (14-07-2015)
		SG11201501851QA	29 April 2015 (29-04-2015)
		WO2014051570A1	03 April 2014 (03-04-2014)
US2014083682A1	27 March 2014 (27-03-2014)	US2014083682A1	27 March 2014 (27-03-2014)
		US8919439B2	30 December 2014 (30-12-2014)
		AU2012391059A1	30 April 2015 (30-04-2015)
		AU2012391059B2	02 February 2017 (02-02-2017)
		EP2900906A1	05 August 2015 (05-08-2015)
		EP2900906A4	24 August 2016 (24-08-2016)
		MX2015003818A	12 October 2015 (12-10-2015)
		SG11201501844UA	29 April 2015 (29-04-2015)
		US2014083675A1	27 March 2014 (27-03-2014)
		US8746337B2	10 June 2014 (10-06-2014)
		WO2014051564A1	03 April 2014 (03-04-2014)
US2008296019A1	04 December 2008 (04-12-2008)	US2008296019A1	04 December 2008 (04-12-2008)
		US7591312B2	22 September 2009 (22-09-2009)
		AU2008259910A1	11 December 2008 (11-12-2008)
		AU2008259910B2	06 June 2013 (06-06-2013)
		BRPI0812583A2	31 March 2015 (31-03-2015)
		CA2688532A1	11 December 2008 (11-12-2008)
		EG25338A	14 December 2011 (14-12-2011)
		EP2153023A2	17 February 2010 (17-02-2010)
		EP2153023B1	10 October 2012 (10-10-2012)
		WO2008151052A2	11 December 2008 (11-12-2008)
WO2008151052A3	18 March 2010 (18-03-2010)		