

(No Model.)

4 Sheets—Sheet 1.

F. R. H. THOMAS.
BOTTLE FILLING MACHINE.

No. 567,555.

Patented Sept. 8, 1896.

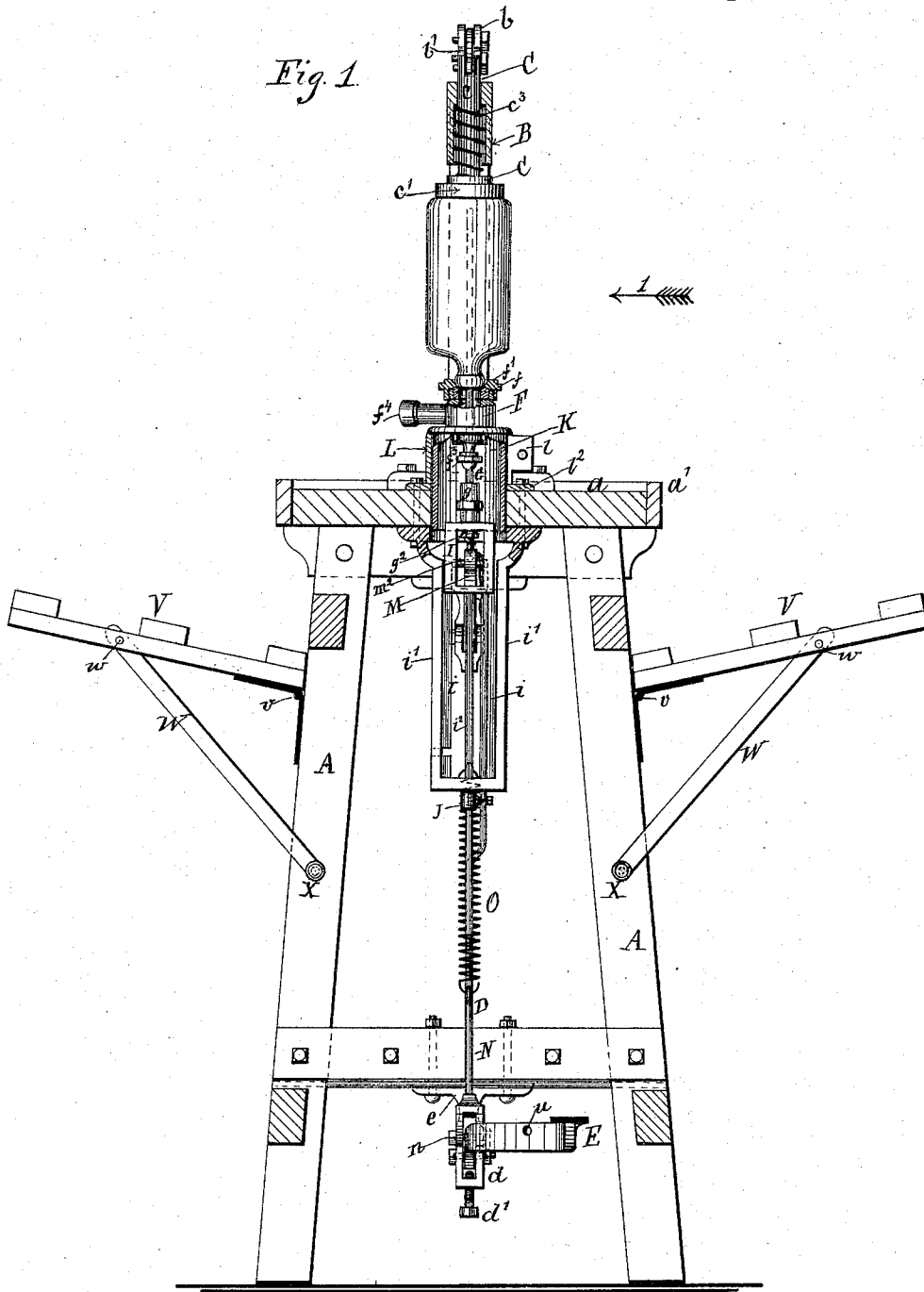

Witnesses
Leopold Almquist
A. Wahlberg

By his Attorney

Inventor
F. R. H. Thomas
A. W. Almquist

(No Model.)

4 Sheets—Sheet 2.

F. R. H. THOMAS.
BOTTLE FILLING MACHINE.

No. 567,555.

Patented Sept. 8, 1896.

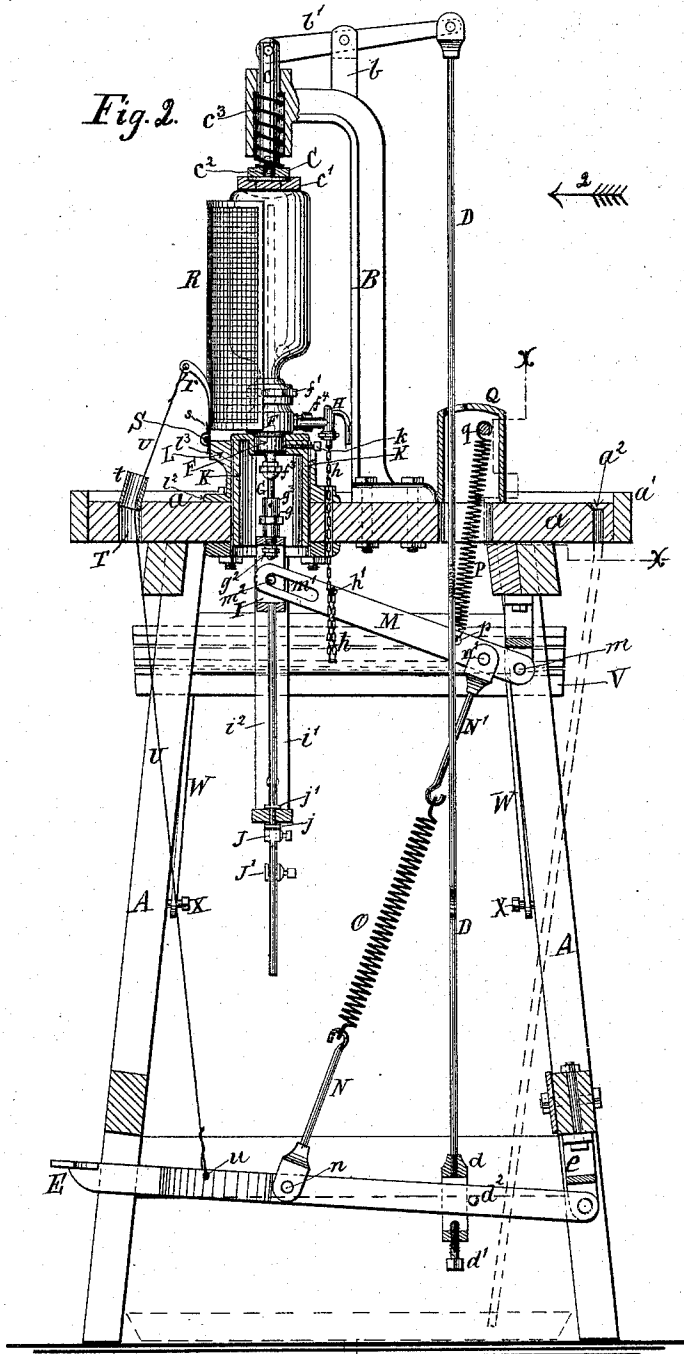

Witnesses
Leopold Almqvist
J. Wahlberg

Inventor
F. R. H. Thomas
By his Attorney *A. W. Almqvist*

F. R. H. THOMAS.
BOTTLE FILLING MACHINE.

No. 567,555.

Patented Sept. 8, 1896.

Fig. 4.

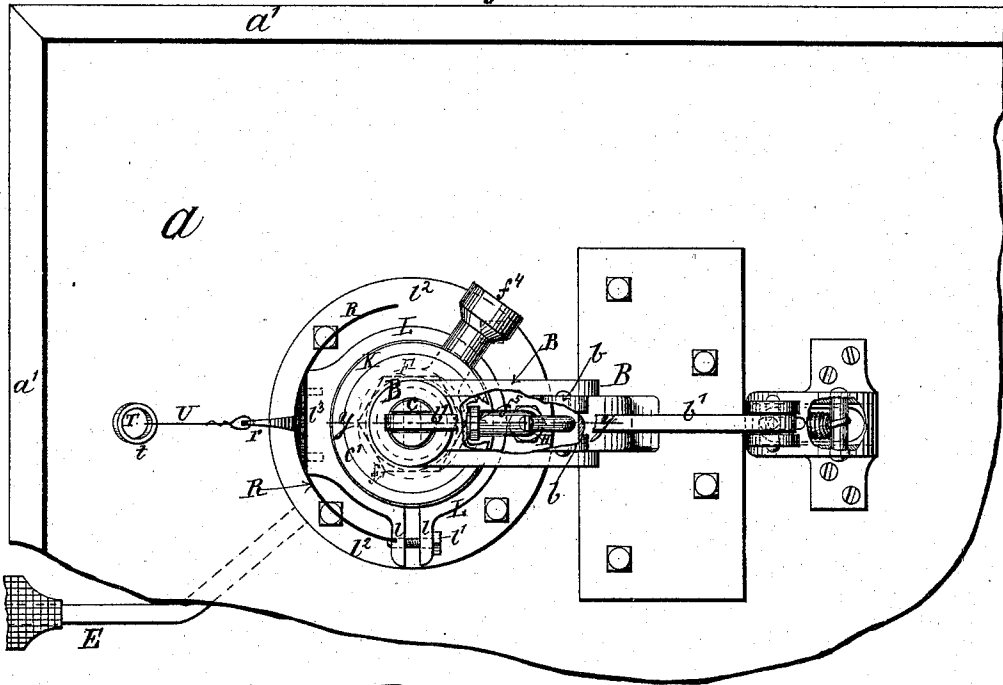

Fig. 5.

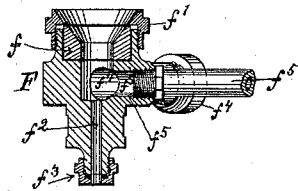

Fig. 6.

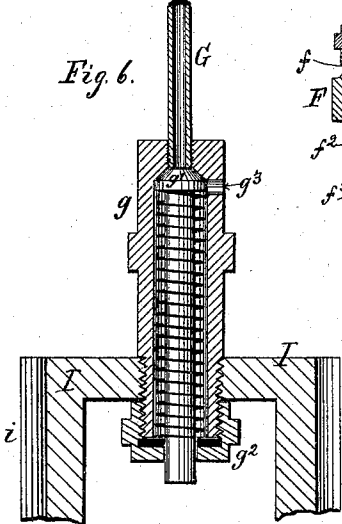
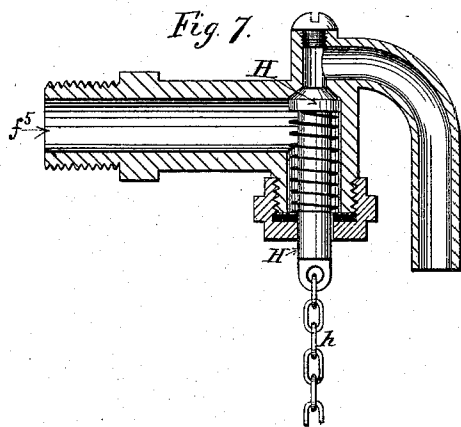

Fig. 7.



Witnesses
Leopold Almquist
H. Wahlberg

Inventor
F. R. H. Thomas
 By his Attorney *A. W. Almquist*

UNITED STATES PATENT OFFICE.

FREDERIC R. H. THOMAS, OF CATSKILL, NEW YORK, ASSIGNOR TO
IMOGEN N. THOMAS, OF SAME PLACE.

BOTTLE-FILLING MACHINE.

SPECIFICATION forming part of Letters Patent No. 567,555, dated September 8, 1896.

Application filed September 8, 1894. Serial No. 522,502. (No model.)

To all whom it may concern:

Be it known that I, FREDERIC R. H. THOMAS, a citizen of the United States, and a resident of Catskill, in the county of Greene and State of New York, have invented certain new and useful Improvements in Bottle-Filling Machines, of which the following is a specification.

The object my invention is to provide an easily-manipulated machine which will enable with great rapidity the inserting, filling, and removing when filled, of bottles to contain soda-water or other gas-charged beverages or liquids under pressure. This is done in such a manner that by and during one single downstroke of a treadle or lever an anti-explosion protecting-screen and the interior air-discharge pipe are removed and withdrawn from the filled bottle, the bottle is corked, the unavoidable, though slight, spilling under the pressure-closed stopper, at the moment of closing, after withdrawal of the air-pipe, is discharged by automatic opening of a self-closing valve, the bottle is released, and replaced by another; and on removing the pressure from the treadle the movable parts resume on the upstroke automatically their normal positions, clamping the newly-inserted empty bottle, closing the spill-valve, inserting the air-pipe into the bottle, and replacing the bottle-screen in position to protect the operator. Then the supply-valve for the gas-charged liquid or beverage is turned open and again closed when the bottle is full. When by and at the end of the next downstroke of the treadle the clamp is withdrawn, the operator by one hand removes the filled bottle and by the other hand replaces it with an empty bottle, and so on continuously, each stroke of the treadle requiring only about one second of time, and the filling *per se* of ordinary small bottles requires about two seconds. Thus fifteen to sixteen bottles may be filled in one minute and a proportionately less number of larger-sized bottles, the machine being also adjustable to receive bottles of various sizes.

The invention will be hereinafter fully described, and pointed out in the claims, reference being had to the accompanying four sheets of drawings, in which—

Figure 1 represents a front elevation of my

improved bottle-filler, parts of the framework, supply-chamber, and its adjustable support with clamping device, air-pipe guide-bracket and bottle-clamp bracket being shown in section. Fig. 2 is a sectional elevation of the same, seen in direction of arrow 1 of Fig. 1. Fig. 3 is a rear view of the same or as seen in direction of arrow 2 of Fig. 2 and partly broken out along the irregular section line *xx* of said figure. Fig. 4 is a top or plan view partly broken out and drawn to a scale about twice as large as the previous figures. Fig. 5 is a central section of the supply-chamber, taken on the line *yy* of Fig. 4. Fig. 6 is a full-sized section of the air-escape valve and part of its supporting slide-frame, taken on a central line at right angles to said line *yy* of Fig. 4. Fig. 7 is a full-sized section of the spill-valve, taken on the said line *yy* of Fig. 4.

A designates the frame of the machine, and *a* the top of the said frame, which constitutes the table upon which the filling is performed, and is surrounded with a flange *a'* to prevent any spilling or dripping of liquid from the table, except through a specially provided discharge *a''* at a lowered spot of its surface, from which it may be conveyed by a pipe to a trough under the machine, as shown in Fig. 2, and thence by a pipe through the floor to the ground, or directly from the discharge *a''* to the ground, as may be most expedient.

Upon the table *a* is firmly secured a bracket B, having an overhanging arm with lug *b*, to which is fulcrumed a lever of the first class *b'*, one end of which is connected to the shank *c* of the bottle-clamp C, fitted to slide vertically in the end of the said overhanging arm of the bracket, the other end of the lever being connected by a rod D to the operating-treadle E, which is a lever of the second class and fulcrumed to a lug or bracket *e*, secured to the frame A.

In order to regulate the time for starting the clamp C, and also the proper throw of the lever *b'* for raising it the required distance, the lower end of the rod D has secured to it an iron strap or band *d*, which surrounds the treadle or foot-lever by a vertical slot sufficiently longer than the height of the cross-section of the treadle to allow of a cer-

tain amount of motion of the latter before it pulls down the rod. A set-screw d' through the lower end of the strap forms and regulates the point and time of contact with the treadle, and a pin d^2 crosswise through the treadle stops the strap d and rod D at the proper leverage distance from the fulcrum of the treadle.

To the head of the bottle-clamp C is secured a wooden face plate or block c' , for non-damaging contact with the bottom of the glass bottle. To the upper surface of the block c' is secured a metal plate having centrally a threaded stud c^2 , fitting a corresponding axial female thread in the clamp C, so that the face-plate may be unscrewed from the clamp C a little, and thereby lowered, more or less, to insure a firm grip also upon any bottle which, through some irregularity in the make, may be a little shorter than the uniform height intended for bottles of the same capacity. A powerful spiral spring c^3 , surrounding the shank c in the bracket B, keeps the clamp C normally depressed as far as it can slide, until stopped by the end of the lever b' coming in contact with the upper surface of the bracket.

F is the supply-chamber, having an annular recess to receive a rubber or other elastic ring f , held in place by a coupling-nut f' , ring and nut being countersunk, as shown in Fig. 5, so as to form a funnel-shaped guide and valve-seat for centering the bottle-mouth upon the ring f when depressed by the clamp C. The cylindrical bore of the ring f coincides with the similar bore of the chamber F, and from the bottom of the latter an axial smaller hole f^2 is bored through the metal, in which the air-escape pipe G slides, being kept tight by a packing-box f^3 . The gas-charged liquid enters the chamber through the inlet f^4 , and f^5 is an outlet-channel to which the spill-valve H is connected.

The air-pipe G (see Fig. 6) is secured with its lower end to the upper end of the casing g of the air-escape valve g' , which normally is kept closed by a spiral spring surrounding the valve-stem, the latter being fitted to slide in the stuffing-box g^2 , while the valve proper g' slides in the casing g , and, when depressed by the gas-pressed air, allows the latter to escape from the bottle through the lateral vent g^3 in the casing g . The valve-casing g is screwed into the upper end of a cross-head I, sliding in the V-guides i of a vertical frame i' , which latter is bolted to the under side of the table a in such position that the air-pipe may be reciprocated in the axial line of the bottle.

A rod i^2 , secured to the cross-head I, slides in a hole through the bottom of the guide-frame i' , and screw-clamps J J', (in connection with elastic washers j, j'), adjustable upon the rod i^2 , limit the stroke of the rod i^2 and thereby also of the cross-head i , to regulate the stroke of the air-pipe G proportionately to the height or depth of bottles of various sizes.

The screw-clamp J, as shown in Fig. 2, by stopping against the under side of the bottom or cross-bar of the guide-frame i' , limits the upstroke and thereby the depth to which the air-pipe shall enter the bottle, the limit of withdrawal being the point at which the cross-head on the downstroke touches the washer j' on top of said cross-bar, and the clamp J (open at one side to adapt its being attached to the rod i^2 laterally, as well as from the end, and held where shown only when not in use) is applied to the rod i^2 above the said cross-bar to shorten the down stroke to suit a shorter bottle. In order to adjust its elevation to adapt it to bottles of different heights, the supply-chamber F is secured by a set-screw k in a hole through the bottom of a cylindrical inverted thimble K, (see Figs. 1, 2, and 4,) which is clamped by means of perforated lugs l and bolt l' in a split circular bracket L, having bottom flange l^2 , through which it is bolted to the top of the table a , so that by clamping the said thimble in a higher or lower position the supply-chamber will be held at a corresponding elevation to suit a shorter or higher bottle, respectively.

The spill-valve H, whose casing is screwed into the outlet f^5 of the supply-chamber F, is constructed upon the same principle as the air-escape valve, except as to the direction of the channels in its casing, as seen in Fig. 7; but the spiral spring which surrounds the valve-stem is strong enough to keep the valve closed against the gas-pressure and until opened automatically by the downward movement of the lever M, when a bottle is filled and the supply-valve closed, for which purpose the valve-stem is connected to the lever by a chain h , whose lower end is hooked (by one or other of its links, according to the required range of stroke) upon a pin h' , secured to the said lever M. The lever M is fulcrumed with one end, at m , to the frame A, or to a lug attached to the frame, and has at its other end a slot m' , by which it engages a pin m^2 , secured to the cross-head I.

N and N' are links or rods pivoted at n and n' by jaw and pin, as shown in Fig. 2, to the treadle E and lever M, respectively, and are connected together by a spiral spring O, of sufficient strength to pull down the lever M to the end of its throw without yielding when the treadle is depressed the corresponding distance and at the same time overcome the resistance of another spiral spring P, by whose force the treadle, when the downward pressure is removed therefrom, is raised into its normal position. The spring P is attached at p and q , respectively, to the lever M and to a pin secured to and within a hollow bracket Q, which latter is bolted upon the table a around a hole, through which and through the said bracket the rod D also passes.

In order to protect the operator against explosion of a bottle by excessive gas-pressure, a semicircular wire screen R is normally kept in position to surround the side of the bottle

nearest to the operator, as shown in Figs. 2 and 4, by being hinged to a flat portion B of the vertical edge of the circular bracket L by a hinge S, having around its pintle a coiled spring s , tending to open the said hinge and thereby keep the screen in the position shown in the drawings. To the screen is secured a forward-curved arm r , from which a chain, cord, or wire U runs through a hole T in the table a down to the point u , where its lower end is attached to the treadle, so that by depressing the treadle the screen is swung down forward away from the bottle.

In the hole T is inserted a metal tube t , projecting above the table and inclined toward the screen, which tube affords a guide and wearing-surface for the chain to slide on.

On each of the opposite left and right sides of the frame A is a shelf V, hinged to the frame at v and supported at a suitable inclination to the frame by one or more braces W, pivoted to the shelf at w and having at the lower end a notch w' , engaging and bearing upon a pin X, secured in the frame A.

The tube t and brackets L and Q fit tightly and project above the table a with water-tight walls sufficiently high to prevent any liquid spilled on the table from flowing down through the apertures in or around which they are fastened.

The points n' and p at which the springs N' and P are attached to the lever M may be interchanged, or their distances from the fulcrum m otherwise varied, if necessary, so as to give the lower spring sufficient leverage to prevent any vertical vibration of the air-tube G due to the pull of the upper spring when the lever M is suddenly stopped at the end of its downstroke.

To lessen the compass of the machine in transportation the braces W are lifted off at the studs or pins X and the shelves V folded upon the surface of the frame A.

In working the machine the operator places on one of the shelves V an empty box and on the other shelf a box full of empty bottles to be filled and depresses the treadle. Inserting the bottle inverted between the clamp C and the supply-chamber F, he removes the pressure from the treadle. The spring P, free to contract, raises the lever M and thereby also the treadle, the slide I, and air-tube C (causing the latter to enter nearly to a point of contact with the bottom of the bottle) and allows the spring-hinge S to bring the screen or guard R in the protecting position. He then turns on the supply-valve. The gas-charged liquid entering by way of inlet f^1 , chamber F, and bottle-neck, fills the bottle and displaces the air therein, which, passing through the tube G, in its turn depresses the valve g' and escapes through the lateral vent g^2 . The bottle filled, he closes the supply and depresses the treadle as far as it will go.

When, during this movement the lever M has reached the stop or limit of its downstroke, the screen is swung down and the air-tube

withdrawn from the bottle, the internal stopper pressed to its seat by the gas, the spill-valve pulled open by its chain n , and the spring P stretched or set ready to effect the return stroke. The spring O now yielding to the farther downward movement of the treadle, (while lever M stands still,) the latter engages the set-screw d' in the strap d and, by means of rod D and lever b' , raises the clamp C against the resistance of its spring c^3 and releases the filled bottle. Grasping this with one hand and placing it in the empty box, the operator simultaneously grasps with his other hand an empty bottle, and placing the same under the clamp, raises his foot which rests upon the treadle, and so on continuously. I am aware that an air-escape pipe for this purpose is old; but its insertion and withdrawal has heretofore been effected by hand by separate movements independent of the rest of machinery and consequently much slower in operation.

Having thus described my invention, I claim—

1. In a bottle-filling machine, the combination of a treadle, bottle-clamp, supply-chamber having a spill-valve H self-closing against the gas-pressure, air-escape tube sliding through said chamber, a lever operating the said tube and operated by said treadle, and a chain or cord h connecting the said spill-valve and lever,—for effecting the opening of the spill-valve simultaneously with the completed withdrawal of the air-tube by the depression of the treadle.

2. In a bottle-filler, a bottle-clamp, a lever b' connected therewith, a treadle, a lever as M and connections acting on the neck end of the bottle, said lever having a connection with said treadle, an operating-rod D connected with said lever b' and with said treadle by means of a strap d , the said strap allowing a limited movement of the treadle without moving said rod, whereby the movement of the treadle causes the lever M and its connected parts to operate before the clamp-operating rod D is moved, substantially as described.

3. In a bottle-filler, the combination of: a supply-chamber, a sliding air-escape tube and stops to regulate and limit the stroke of the same, a lever operating the said tube, a treadle operating said lever, a bottle-clamp-operating rod D attached to the treadle by a connection as d , and an elastic connection, as O, from said treadle to said lever, said connection O yielding on the completed withdrawal stroke of the air-tube, while the treadle descends farther to pull down the rod D and release the bottle-clamp.

4. In a bottle-filler, the cylindrical thimble K having aperture for receiving and set-screw k for retaining the supply-chamber, in combination with the circular, split clamp-ing-bracket L,—for adjusting the elevation of the supply-chamber according to various sizes of bottles.

5. In combination with the treadle of a bot-

5 tle-filling machine: a bottle-clamp, a rod D
 actuating said clamp and connected to the
 said treadle; a sliding air-escape tube, a lever
 M actuating said tube and elastically con-
 10 nected to the said treadle; a supply-chamber
 having a spill-valve operated by the move-
 ment of said lever M connected to the treadle;
 and a spring-hinged guard-screen R con-
 15 nected by chain or wire U to the said treadle;
 for the purpose of effecting successively, the
 withdrawal of the screen and air-tube, the
 opening of the spill-valve, and the unclamp-
 ing of the bottle—all with one single down-
 20 stroke of the treadle.
 6. In a bottle-filling machine, a guard-

screen, an air-escape tube, a bottle-clamp, a
 treadle, and a spill-valve and intermediate
 connections arranged to operate all of said
 parts on the downstroke of said treadle, and
 a spring set by the downstroke of the treadle
 and effecting by its elastic force the return-
 stroke, substantially as described.

Signed at Catskill, in the county of Greene
 and State of New York, this 29th day of
 August, A. D. 1894.

FREDERIC R. H. THOMAS.

Witnesses:

A. W. ALMQUIST,
 CHAS. G. COFFIN.