

(No Model.)

2 Sheets—Sheet 1.

J. E. BUCKLIN.
COPY HOLDER.

No. 526,990.

Patented Oct. 2, 1894.

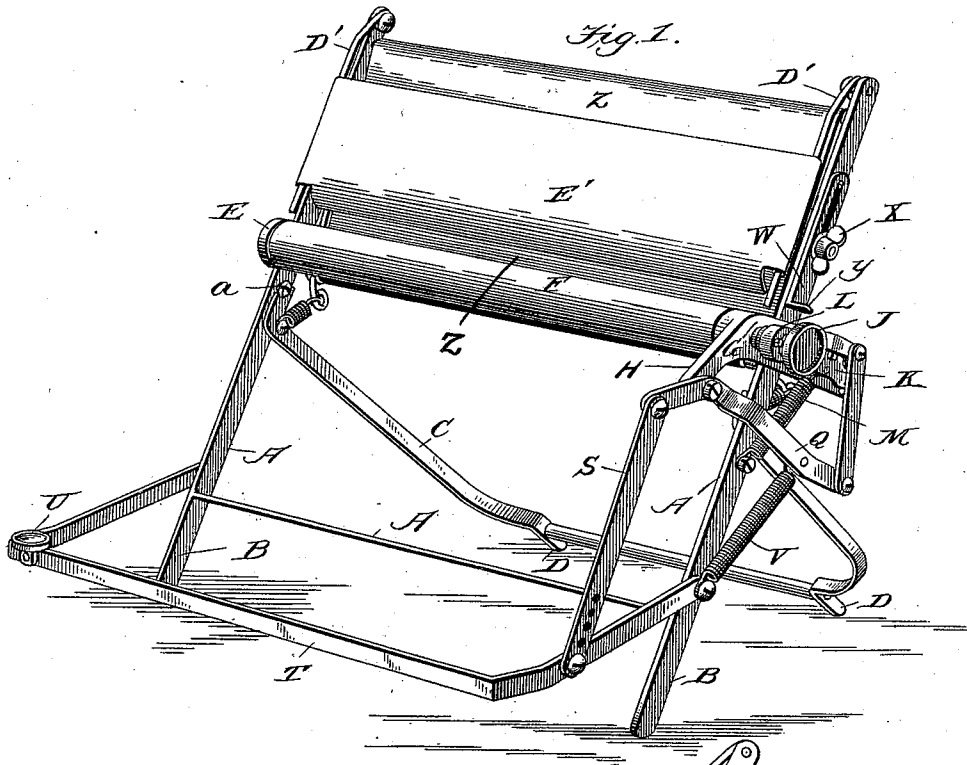
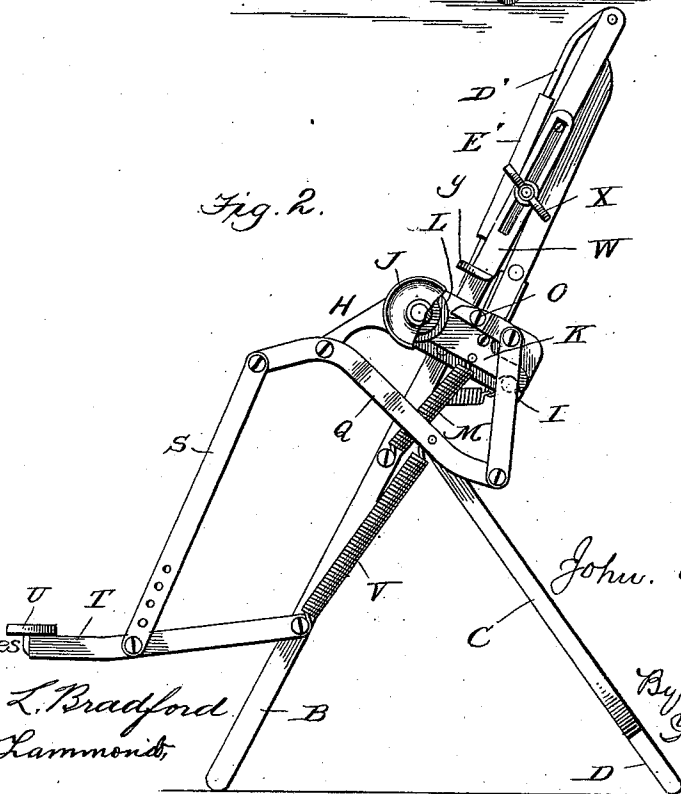

Fig. 2.



Witnesses

Edwin L. Bradford
N. Curtis Hammond

John. E. Bucklin

Inventor

By *Wm. C. Crutcher*
Attorney

(No Model.)

2 Sheets—Sheet 2.

J. E. BUCKLIN.
COPY HOLDER.

No. 526,990.

Patented Oct. 2, 1894.

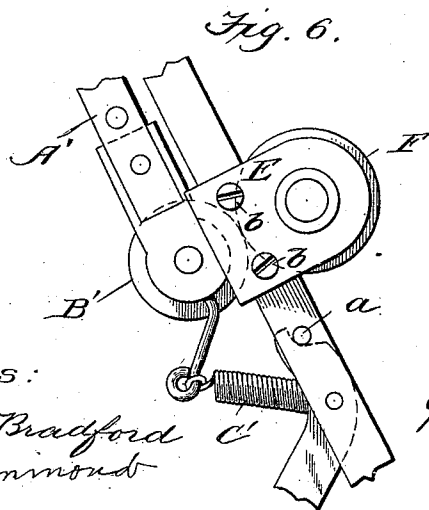
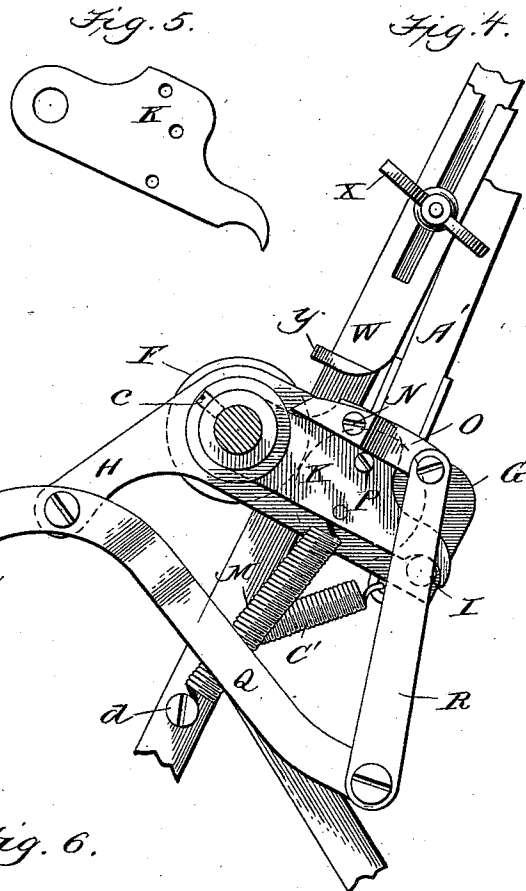
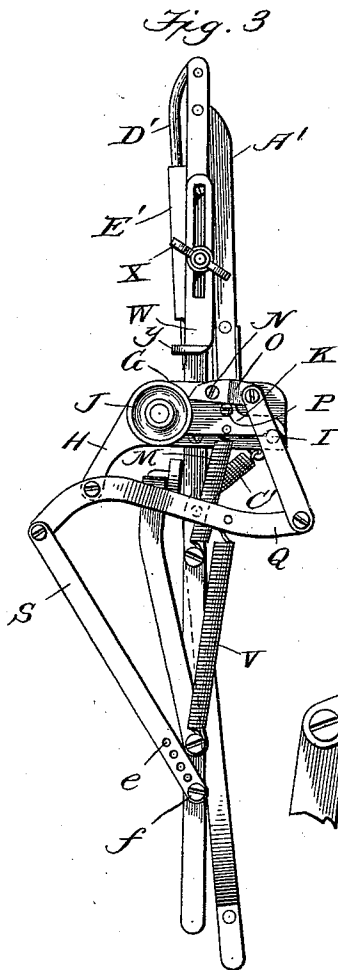

Witnesses:

Edwin L. Bradford
N. Curtis Lammond

John E. Bucklin
Inventor

By Wm. C. Squire
Attorney

UNITED STATES PATENT OFFICE.

JOHN E. BUCKLIN, OF WASHINGTON, DISTRICT OF COLUMBIA, ASSIGNOR TO
THE BUCKLIN COPY HOLDER COMPANY, OF RICHMOND, VIRGINIA.

COPY-HOLDER.

SPECIFICATION forming part of Letters Patent No. 526,990, dated October 2, 1894.

Application filed May 29, 1894. Serial No. 512,849. (No model.)

To all whom it may concern:

Be it known that I, JOHN E. BUCKLIN, a citizen of the United States, residing at Washington, in the District of Columbia, have invented certain new and useful Improvements in Copy-Holders; and I do hereby declare the following to be a full, clear, and exact description of the invention, such as will enable others skilled in the art to which it appertains to make and use the same.

My invention relates to certain new and useful improvements in copy holders for typewriters and particularly to that class in which the copy moving cylinder is operated by a pivoted swinging key or lever.

My invention has for its object to provide a copy holder which shall be economic of construction, adjustable in its parts and compact in form, so that any given extent of the copy may be exposed to view and the copy moved in such manner that the lines of the copy will progress to the same extent as the matter is printed upon the sheet in the typewriter, thus enabling the operator to successfully make lineal copies.

With these ends in view my invention consists in the details of construction and the combination and arrangement of parts hereinafter fully described and specifically claimed.

In order that those skilled in the art to which my invention pertains may know how to make and use my improved copy holder I will proceed to describe the construction and operation of the same referring by letters to the accompanying drawings, in which—

Figure 1 is a perspective view of a copy holder embodying my invention. Fig. 2 is a side elevation partly in section. Fig. 3 is a side elevation showing the holder folded up in its most compact form for transportation. Fig. 4 is a side view on an enlarged or full sized scale and broken away above and below the moving cylinder. Fig. 5 is a full size plan view of the swinging plate to which the cylinder operating dog is pivoted; and Fig. 6 is a partial side view taken at the end opposite to that shown in Fig. 5 and illustrates the arrangement and means employed to secure a proper bite between the moving cylinder and the auxiliary cylinder or roll.

Similar letters indicate like parts in the several figures of the drawings.

A is a frame composed preferably of metal and fashioned at its lower end in any suitable manner to provide supporting legs or feet B, B. Pivoted to the frame A below the moving cylinder is an auxiliary frame C terminating at its free end in feet or supports D, and the outward movement of said auxiliary frame is limited by the contact of the upper extension of said frame with the stops *a* on the main frame A. (See Figs. 1 and 6.)

On the main frame A at the left hand side is secured by screws *b* a journal bearing E into which one end of the journal of the cylinder F takes its bearing. To the opposite side of the frame A is secured in a similar manner a plate G (see Fig. 4 particularly) which serves as the journal bearing for the opposite end of cylinder F. This plate G is formed with a curved or oblique arm H and is extended rearward and provided with a stud or stop I. (Shown in dotted lines.)

The journal of the cylinder F takes its bearing in the plate G and extends through the same and is provided at its extreme end with a milled thumb wheel J, by means of which the cylinder may be readily rotated in either direction. The journal also passes through a plate K (see Fig. 5) and between this plate and the milled wheel J there is secured to the shaft or journal of the cylinder F, preferably by a set screw *c* (see Fig. 4) a friction wheel L.

The plate K is free to vibrate upon the shaft of the cylinder F, and its upward movement is controlled by mechanism presently described, and its return movement by the stop I and retracting spring M, one end of which is secured to a stud on said plate and the opposite end to a stud *d* on the main frame A.

To the plate K is pivoted at N a friction dog O, the downward movement of which is limited by a screw or stud P secured to the swinging plate K.

Q is an irregularly curved arm or lever pivoted at a point between its ends to the arm H of the plate or bearing G. The rear end is pivoted to a link bar R, the upper end of

which is pivoted to the heel or rear end of the dog O. The forward end of the arm Q is pivotally connected with a flat rod or link S, the lower end of which is, by a series of holes *e* and a screw *f*, adapted to be adjustably pivoted to the end of a swinging operating frame T pivoted at each end to the main frame A, and provided at any suitable locality with a key U.

10 The irregularly curved vibrating arm Q back of and below the point at which it is pivoted to the arm H is connected by a spring V to the main frame preferably with the pivot by which the swinging frame T is also connected.

15 W is an adjustable plate provided with a longitudinal slot and a set screw X, and formed at its lower end with a stop Y which limits the upward movement of the swinging plate K to which the friction dog O is pivoted, and hence the extent of the rotation of the cylinder F is controlled.

20 The upper ends of the main frame A are connected by a horizontal rod around which is secured the upper edge of a sheet metal swinging copy support Z the lower edge of which lies just below the upper peripheries of the rollers F, and B' as shown in Fig. 1, and serves to also guide the sheet into the bite of the said rollers. To this horizontal bar is also pivoted a vertical swinging frame A' between the lower ends of which is secured in suitable bearings a clamping roller or cylinder B', and the lower ends of the frame A' are connected with the main frame A by spiral springs C' to produce the proper bite between the rollers or cylinders F and B' between which the copy is held.

30 D', D' are two swinging arms pivoted at their upper ends to the extreme ends of the main frame A and frictionally secured to these arms D', D' is a flat plate E' which may be adjusted to different altitudes upon said arms, so that the lower edge of the said plate may be so adjusted as to vary the space or sight line between its lower edge and the periphery of the cylinder or roll F so that any given amount of the copy may be exposed, but by preference the parts are so adjusted that but a single line of the copy is visible at the point between the plate and the roller, although the entire copy may if so desired be exposed by swinging the arms D' and plate E' upward and over.

55 To fold up the device in order that it may be made compact for transportation, the screw or pivot which secures the lower end of the arm S to the frame T is removed. The frame T is then folded up as shown at Fig. 3

and the auxiliary frame C is likewise folded 60 or swung toward the main frame A. A still further reduction of compass may be effected by removing the pivots which connect the lower end of the arm Q and the link R. When the parts are in their normal and proper relation to each other the friction dog O is 65 slightly away from or out of contact with the friction wheel or pulley J, and when pressure is applied to the key U and the frame T is depressed, the rod or link S pulling upon the arm Q causes it to vibrate upon its pivot in the arm H forcing up the link R and bringing the biting edge of the dog O in contact with the periphery of the friction wheel J, and then the plate K and dog O vibrate upon the 75 shaft of the cylinder, rotating the same and the roller or cylinder F a distance proportionate to the movement of the frame T which as before stated will be limited by the fact that the upper edge of the plate K comes in contact with the adjustable stop Y, and the copy which is in the bite of the rolls F and B' is forced upward accordingly. When the pressure is removed from the key U and frame T the spring V pulls down the rear 85 end of the arm Q and with it the dog O until the latter comes in contact with the stop P on the swinging plate K, and the latter is at the same time drawn downwardly by the spring V until the rear end of said plate 90 comes in contact with the stop I, thus releasing contact between the dog and friction wheel.

Having described the construction and operation of my improved copy-holder, what I 95 claim as new, and desire to secure by Letters Patent, is—

1. In combination with the frame A and plates E, G, having the cylinder F mounted therein said cylinder being provided with 100 friction wheel J the swinging plate K, pawl or dog O pivoted thereto, link R, arms Q and H, rod S, swinging frame T, retracting springs M, V, and stops I, P, substantially as and for the purpose set forth. 105

2. The combination and arrangement of the frame A, roll or cylinder F, journaled therein, the roll B', journaled in the swinging frame A', plate Z, swinging arms D', D' and adjustable plate E', substantially as and 110 for the purpose set forth.

In testimony whereof I affix my signature in presence of two witnesses.

JOHN E. BUCKLIN.

Witnesses:

WM. C. MCINTIRE,
N. CURTIS LAMMOND.