

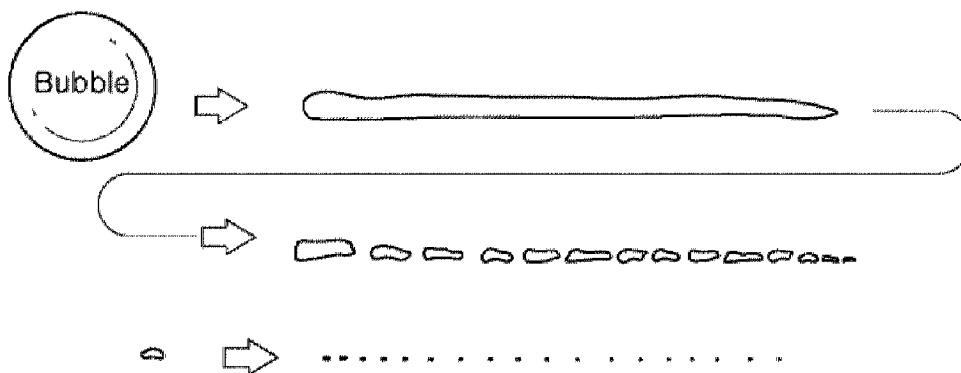

(86) Date de dépôt PCT/PCT Filing Date: 2020/07/30
 (87) Date publication PCT/PCT Publication Date: 2021/04/15
 (45) Date de délivrance/Issue Date: 2024/01/16
 (85) Entrée phase nationale/National Entry: 2022/04/08
 (86) N° demande PCT/PCT Application No.: KR 2020/010033
 (87) N° publication PCT/PCT Publication No.: 2021/071072
 (30) Priorité/Priority: 2019/10/11 (KR10-2019-0126340)

(51) Cl.Int./Int.Cl. *B01F 23/2375* (2022.01),
B01F 23/233 (2022.01), *B01F 27/1151* (2022.01)
 (72) Inventeurs/Inventors:
YOO, YOUNG HO, KR;
YOO, TAE GEUN, KR;
YOO, A RAM, KR
 (73) Propriétaires/Owners:
YOO, YOUNG HO, KR;
FAWOO NANOTECH CO.,LTD., KR
 (74) Agent: BORDEN LADNER GERVAIS LLP

(54) Titre : SYSTEME DE GENERATION DE NANOBULLES UTILISANT LE FROTTEMENT
 (54) Title: NANOBUBBLE GENERATION SYSTEM USING FRICTION



(57) **Abrégé/Abstract:**

The present disclosure relates to a nanobubble generation system using friction in which, by efficiently applying a frictional force to bubbles included in a gas-liquid mixed fluid by excluding a stator, the atomization of the bubbles is induced and nanobubbles are generated. The nanobubble generation system includes: a chamber including an inlet, an outlet, and an internal space S configured to atomize bubbles included in a gas-liquid mixed fluid; one or more strikers each including a plurality of protrusions provided on a body thereof to simultaneously apply impact to the gas-liquid mixed fluid that flows into the chamber and swirl the fluid in order to cause the gas-liquid mixed fluid to rub against an inner wall of the chamber, the strikers being provided on the driving shaft; a plurality of friction elements provided on the driving shaft in order to apply frictional force to the gas-liquid mixed fluid; and a driving mechanism including the driving shaft and configured to rotate the striking friction elements, wherein the friction elements are arranged on the driving shaft to be spaced apart from each other at a predetermined interval, and peripheral surfaces of bodies of the friction elements directly face the inner wall of the chamber with a predetermined distance therebetween.

Abstract

The present disclosure relates to a nanobubble generation system using friction in which, by efficiently applying a frictional force to bubbles included in a gas-liquid mixed fluid by excluding a stator, the atomization of the bubbles is induced and nanobubbles are generated. The nanobubble generation system includes: a chamber including an inlet, an outlet, and an internal space S configured to atomize bubbles included in a gas-liquid mixed fluid; one or more strikers each including a plurality of protrusions provided on a body thereof to simultaneously apply impact to the gas-liquid mixed fluid that flows into the chamber and swirl the fluid in order to cause the gas-liquid mixed fluid to rub against an inner wall of the chamber, the strikers being provided on the driving shaft; a plurality of friction elements provided on the driving shaft in order to apply frictional force to the gas-liquid mixed fluid; and a driving mechanism including the driving shaft and configured to rotate the striking friction elements, wherein the friction elements are arranged on the driving shaft to be spaced apart from each other at a predetermined interval, and peripheral surfaces of bodies of the friction elements directly face the inner wall of the chamber with a predetermined distance therebetween.

NANOBUBBLE GENERATION SYSTEM USING FRICTION

Technical Field

5 The present disclosure relates to a nanobubble generation system using friction in which, by efficiently applying a frictional force to bubbles included in a gas-liquid mixed fluid by excluding a stator, the atomization of the bubbles is induced and nanobubbles are generated.

10

Background Art

 In general, depending on the sizes, microbubbles are classified according to their size into microbubbles having a diameter of 50 μm or less and nanobubbles having a diameter of several hundred nm or less.

15

 Microbubbles are very fine bubbles of 50 μm or less, rise to the water surface at a very slow rate of 0.1cm/sec, disappear within 2 to 3 minutes after being generated, and have a cloudy milky color in water.

20

 Nanobubbles are ultrafine microbubbles generated by intensively atomizing microbubbles and having a very small size of several hundred nm or less. The nanobubbles have various characteristics different from normal bubbles and microbubbles, and are transparent, so it is impossible to identify them with the naked eye in a general environment even if the microbubbles are floating in water.

25

 Microbubbles in water are temporarily maintained in a stable state and then disappear as described above, whereas nanobubbles may be stably maintained for a long period of time up to several tens of days or more since the peripheries thereof are thickly surrounded by concentrated ion flows.

30

 These nanobubbles generate various energy when they are extinguished and are used in various fields throughout the

industry, i.e., for various aquaculture and hydroponics in the fishing and agriculture fields, for precision diagnosis and physical therapy in the medical field, high-purity water purification/refining treatment of wastewater and waste oil, sterilization, disinfection, deodorization, cleaning, and the like in the living field.

For example, in the case of water treatment, it is possible to shorten the treatment time for enhancing water quality by effectively injecting air into the water, and in the case of wastewater or waste oil treatment, it is possible to effectively remove various odor substances contained in the wastewater or waste oil, for example, by effectively injecting a strong oxidizing gas such as ozone.

Conventional techniques for atomizing bubbles usually use the principle of splitting bubbles while applying a shear force to a flowing gas-liquid mixed fluid, and are configured to use a boundary layer effect, turbulence and cavitation phenomena of fluid, and the like. With these techniques, only microbubbles are mainly generated, and the generation of nanobubbles is very insignificant. Thus, these techniques have not reached the level of practical use.

Korean Patent No. 10-1969772 (issued on April 17, 2019) (hereinafter, referred to as "Prior Art 1"), which is one of the conventional techniques, discloses a configuration in which guide blades disposed at an inlet and outlet of a mixing part (chamber) to guide the flow of fluid, and rotors and stators having a meshing structure are continuously stacked in a housing around a motor shaft, wherein, by the relative rotation of the rotors with respect to the stators, the gears formed to correspond with each other on the stators and the rotors repeatedly strike the fluid, and the turbulence and cavitation pressures of the fluid are increased to apply a shear force to the bubbles, thereby creating microbubbles.

In Prior Art 1 having the above-described configuration, most of bubbles are generated only as microbubbles, so the quality of atomization of generated bubbles is poor and the generated bubbles disappear in a short time. By adopting a structure that forcibly diverts fluid in a zigzag form such that the flow passes through mesh gaps, there are problems in that a flow drag coefficient becomes large, power consumption is large, and productivity is not ensured because the processing flow rate is insufficient.

In addition, since the pressure in the chamber is maintained at a high pressure and it is necessary to provide a large number of rotors and stators having a complex structure, there are problems in that enormous power is wasted in order to operate the rotors and stators and the burden of operating costs is increased.

As another conventional technique different from Prior Art 1, Japanese Patent Laid-Open Publication No. 2009-142442 (issued on July 2, 2009) (hereinafter, referred to as "Prior Art 2") has a structure in which a plurality of rotating disks provided with shearing edges are arranged on a rotating shaft installed in a chamber.

In Prior Art 2, since the rotating disks are rotated independently, rather than being relatively rotated, there are advantages of increasing the ejecting amount of fluid by causing free flow and remarkably reducing power and operating costs. However, by only including the rotating disks having a main function of applying a shear force, there are disadvantages in that only microbubbles are generated, and the bubble generation efficiency is poor.

As described above, the microbubble generation techniques up to now are limited to microbubble generation, and nanobubbles are not practically used in the industrial field despite the excellent utility thereof.

Disclosure of Invention

Technical Problem

The present disclosure has been made to solve the above
5 problems.

In view of the foregoing, the present disclosure provides
a nanobubble generation system using friction in which, by
efficiently applying a frictional force to bubbles included in
a gas-liquid mixed fluid by excluding a stator, the atomization
10 of the bubbles is induced and nanobubbles are generated.

In addition, the present disclosure provides a nanobubble
generation system using friction in which nanobubbles are
efficiently generated by generating the nanobubbles by using the
principle of bubble atomization according to friction after
15 atomizing bubbles contained in a gas-liquid mixed fluid in
advance to a microbubble level.

In addition, the present disclosure provides a nanobubble
generation system using friction, in which a wider effective
friction surface is provided in a fluid flowing process, so that
20 the atomization quality of nanobubbles due to friction and the
efficiency of machine are significantly improved.

Furthermore, the present disclosure provides a nanobubble
generation system using friction in which nanobubbles are
produced in a qualitatively and quantitatively favorable manner
25 so that nanobubbles which are excellent in utility can also be
easily used in an industrial field that requires a large amount
of nanobubbles.

Solution to Problem

30 In view of the foregoing, a nanobubble generation system
using friction according to an embodiment of the present
disclosure includes:

a chamber including an inlet, an outlet, and an internal

space configured to atomize bubbles included in a gas-liquid mixed fluid, the chamber being provided with a driving shaft;

one or more strikers each including a plurality of protrusions provided on a body thereof to simultaneously apply impact to the gas-liquid mixed fluid that flows into the chamber and swirl the fluid in order to cause the gas-liquid mixed fluid to rub against an inner wall of the chamber, the strikers being provided on the driving shaft;

a plurality of friction elements provided on the driving shaft in order to apply frictional force to the gas-liquid mixed fluid; and

a driving mechanism including the driving shaft and configured to rotate the striking friction elements,

wherein the friction elements are arranged on the driving shaft to be spaced apart from each other at a predetermined interval,

the peripheral surfaces of bodies of the friction elements directly face the inner wall of the chamber with a predetermined distance therebetween,

at least one of the friction elements has a line speed of 8 m/sec or more at a tip end of the body thereof in a direction orthogonal to the axis thereof, and

the at least one striker and at least one of the plurality of friction elements are provided with at least one of a distribution hole or a cut-out passage configured to guide a flow of the gas-liquid mixed fluid to a plane perpendicular to the axis thereof.

A nanobubble generation system using friction according to an embodiment of the present disclosure includes:

a chamber including an inlet, an outlet, and an internal space configured to atomize bubbles included in a gas-liquid mixed fluid, the chamber being provided with a driving shaft;

one or more strikers each including a plurality of

protrusions provided on a body thereof to simultaneously apply impact to the gas-liquid mixed fluid that flows into the chamber and swirl the fluid in order to cause the gas-liquid mixed fluid to rub against an inner wall of the chamber, the strikers being
5 provided on the driving shaft;

a plurality of friction elements provided on the driving shaft in order to apply frictional force to the gas-liquid mixed fluid; and

10 a driving mechanism including the driving shaft and configured to rotate the striking friction elements,

wherein the plurality of friction elements are arranged on the driving shaft to be spaced apart from each other at a predetermined interval, and peripheral surfaces of bodies of the friction elements directly face the inner wall of the chamber
15 with a predetermined distance therebetween, and

one or more small-diameter friction elements and one or more large-diameter friction elements having a relatively large radius compared to the small-diameter friction elements are arranged to be spaced apart from each other at a predetermined
20 interval.

The driving shaft is sequentially provided with: a micro-atomization region in which the one or more strikers are arranged along the flow direction of the fluid in order to atomize the bubbles included in the gas-liquid mixed flowing into the chamber
25 to a microbubble level in advance; and

a nano-atomization region which is provided after the front shearing edge in the fluid flow and in which one or more friction elements are arranged in order to ultra-atomize the bubbles, which are atomized into a micro-level, into nanobubbles.

30 The micro-atomization region may be provided with a ring-shaped stator on the inner wall of the chamber to face the strikers, and

the stator may be provided with a plurality of protrusion

around a ring-shaped inner surface thereof.

A nanobubble generation system using friction according to an embodiment of the present disclosure includes:

5 one or more micro-level atomization apparatuses configured to apply an impact and a shear force to a gas-liquid fluid to atomize bubbles to a micro-level; and

10 a nanobubble generation apparatus configured to apply a frictional force to the gas-liquid mixed fluid passing through the micro-level atomization apparatuses to atomize the bubbles into nanobubbles,

wherein the nanobubble generation apparatus includes:

15 a first chamber includes an inlet and an outlet for the fluid and an inner wall that defines a space configured to accommodate the gas-liquid mixed fluid and apply a frictional force to the fluid;

one or more friction elements provided in the first chamber to be rotatable by using a driving shaft and configured to function as a friction mechanism for the fluid that generate a centrifugal force to push the fluid to the inner wall; and

20 a first driving mechanism including the driving shaft in order to rotate the friction elements, and

wherein the micro-level atomization apparatus includes:

25 a second chamber including an inlet, an outlet, and an internal space configured to atomize the bubbles included in the gas-liquid mixed fluid, the second chamber being provided with a driving shaft;

one or more strikers or impellers provided on the driving shaft and each including a plurality of protrusions configured to apply an impact to the fluid; and

30 a second driving mechanism including the driving shaft and configured to drive the strikers or the impellers.

At least one of the friction elements and the strikers may be provided with at least one of a distribution hole and a cut-

out passage configured to guide a flow of the gas-liquid mixed fluid to a plane perpendicular to the axis thereof.

At least one of the friction elements may be an impeller-type friction element including a plurality of vanes.

5 At least one of the strikers of the micro-level atomization apparatus may be provided on the driving shaft of the nanobubble generation system together with the one or more friction elements.

10 In the micro-level atomization apparatus, at least one of the strikers may be provided with a plurality of protrusions on at least the periphery of the body thereof, and

the second chamber may be provided with a plurality of protrusions directly or indirectly on at least a portion of an inner wall thereof.

The micro-level atomization apparatus may be provided with the impeller on the driving shaft,

an inlet of the impeller may be connected to the inlet of the chamber via an inlet pipe, and

20 the micro-level atomization apparatus may be a pump-type micro-level atomization apparatus in which protrusions are radially formed on the inner wall of the second chamber.

Between the impeller of the pump-type micro-stage atomization apparatus and the inner wall of the second chamber, 25 volute-type duct configured to collect and guide the gas-liquid mixed fluid to the inner wall of the second chamber may be provided.

A nanobubble generation system using friction according to an embodiment of the present disclosure includes:

30 a chamber including an inlet, an outlet, and an internal space configured to atomize bubbles included in a gas-liquid mixed fluid, the chamber being provided with a driving shaft; one or more striking/friction elements each including a

plurality of protrusions configured to apply impact to the gas-liquid mixed fluid introduced into the chamber and swirl the fluid to rub against the inner wall of the chamber, and a friction portion configured to apply a frictional force to the fluid, the striking/friction elements being provided on the driving shaft; and

a driving mechanism including the driving shaft and configured to rotate the striking/friction elements,

wherein the striking/friction elements are arranged on the driving shaft to be spaced apart from each other at a predetermined interval, and peripheral surfaces of bodies of the friction elements directly face the inner wall of the chamber with a predetermined distance therebetween.

At least one of the striking/friction elements may be provided with at least one of a distribution hole and a cut-out passage configured to guide a flow of the gas-liquid mixed fluid to a plane perpendicular to the axis thereof.

Advantageous Effects of Invention

With the nanobubble generation system using friction and having the above-described configuration according to the present disclosure,

it is possible to induce atomization of bubbles to generate nanobubbles by efficiently applying a frictional force to the bubbles included in a gas-liquid mixed fluid by excluding a stator.

In addition, it is possible to generate nanobubbles markedly efficiently by generating the nanobubbles by using the principle of bubble atomization according to friction after atomizing bubbles contained in a gas-liquid mixed fluid in advance to a microbubble level.

Due to the organic configuration based the line speed of the friction element, the friction surface, and the proper

distance between the friction element and the inner wall of the chamber, in particular, as a stator is excluded, not only the friction element but also the inner wall of the chamber having a larger area functions as a friction surface, while the entire surface of the body of the friction element functions as an effective friction surface via the distribution holes and the like, the quality of bubble atomization, the amount of dissolved oxygen, and the nanobubble generation ability of the apparatus can be significantly improved compared to the existing techniques, and a large amount of nanobubbles can be generated.

Furthermore, since it becomes possible to generate nanobubbles in a qualitatively and quantitatively favorable manner, nanobubbles excellent in utility can be easily used, especially in industrial fields that require a large amount of nanobubbles.

Brief Description of Drawings

FIGS. 1A and 1B are views illustrating a principle of generating nanobubbles using friction, in which FIG. 1A is a view illustrating atomization according to flow friction of a fluid (bubbles), and FIG. 1B is a view illustrating atomization of a fluid (bubbles) according to rotating friction of a friction element.

FIG. 2 is a vertical cross-sectional view schematically illustrating the configuration of an embodiment of the present disclosure.

FIGS. 3A and 3B are views illustrating the flow of the fluid in FIG. 2, in which FIG. 3A is an enlarged view of part A of FIG. 2, and FIG. 3B is a cross-sectional view taken along line B-B in FIG. 2.

FIG. 4 is a vertical cross-sectional view illustrating the configuration of an embodiment of the present disclosure.

FIG. 5A is a partially omitted cross-sectional view

illustrating the configuration of an embodiment of the present disclosure, and FIG. 5B is a partially omitted cross-sectional view taken along line C-C in FIG. 5A.

FIGS. 6A to 6E are views schematically illustrating arrangement configurations of embodiments of the present disclosure.

FIG. 7A is a vertical cross-sectional view of a nanobubble generation apparatus of an embodiment according to the present disclosure, FIG. 7B is a cross-sectional view taken along line D-D in FIG. 7A, and FIG. 7C is a cross-sectional view of another configuration that is compared with FIG. 7B.

FIG. 8 is a vertical cross-sectional view of a nanobubble generation apparatus according to an embodiment of the present disclosure.

FIG. 9A is a vertical cross-sectional view of a micro-level atomization apparatus of an embodiment according to the present disclosure, and FIG. 9B is a partially omitted cross-sectional view taken along line E-E in FIG. 9A.

FIG. 10A is a partially omitted plan view of a friction element according to an embodiment of the present disclosure, and FIG. 10B is a vertical cross-sectional view of FIG. 10A.

FIG. 11A is a plan view of a friction element according to an embodiment of the present disclosure, and FIG. 11B is a vertical cross-sectional view of FIG. 11A.

FIGS. 12A, 12B, and 12C are plan views of friction elements according to an embodiment of the present disclosure.

FIG. 13A is a partially omitted plan view of a friction element according to an embodiment of the present disclosure, and FIG. 13B is a vertical cross-sectional view of FIG. 13A.

FIG. 14A is a partially omitted plan view of a multi-friction element according to an embodiment of the present disclosure, and FIG. 14B is a vertical cross-sectional view of FIG. 14A.

FIG. 15A is a partially omitted plan view of an impeller-

type friction element according to an embodiment of the present disclosure, FIG. 185 is a vertical cross-sectional view of FIG. 15A, and FIG. 15C is a vertical cross-sectional view of another embodiment corresponding to FIG. 15B.

5 FIG. 16A is a plan view of a striker according to an embodiment of the present disclosure, FIG. 16B is a vertical cross-sectional view of FIG. 16A, and FIG. 16C is a plan view of another example corresponding to FIG. 16A.

10 FIG. 17A is a partially omitted plan view of a striker according to an embodiment of the present disclosure, and FIG. 17B is a vertical cross-sectional view of FIG. 17A.

FIG. 18A is a partially omitted plan view of a striker according to an embodiment of the present disclosure, and FIG. 18B is a vertical cross-sectional view of FIG. 18A.

15 FIG. 19A is a vertical cross-sectional view of a micro-level atomization apparatus according to an embodiment of the present disclosure, and FIG. 19B is a partially omitted cross-sectional view taken along line F-F in FIG. 19A.

20 FIG. 20A is a vertical cross-sectional view of a micro-level atomization apparatus according to an embodiment of the present disclosure, and FIG. 20B is a partially omitted cross-sectional view taken along line G-G in FIG. 20A.

25 FIG. 21A is a vertical cross-sectional view of a micro-level atomization apparatus according to an embodiment of the present disclosure, and FIG. 21B is a partially omitted cross-sectional view taken along line H-H in FIG. 21A.

30 FIG. 22A is a vertical cross-sectional view of a micro-level atomization apparatus according to an embodiment of the present disclosure, and FIG. 22B is a partially omitted cross-sectional view taken along line J-J in FIG. 22A.

FIG. 23 is a vertical cross-sectional view illustrating the configuration of an embodiment of the present disclosure.

FIG. 24A is an enlarged view of part K in FIG. 23, and

FIG. 24B is a cross-sectional view taken along line L-L in FIG. 24A.

Best Mode for Carrying out the Invention

5 Hereinafter, embodiments of a nanobubble generation system using a frictional force according to the present disclosure will be described in more detail with reference to the accompanying drawings.

10 All objects generate heat when pressure accompanying speed is applied thereto. From the time point at which a speed and pressure reach critical points, a phenomenon in which a surface against which an object rubs is crushed with heat to reduce a frictional force occurs.

15 This phenomenon may easily be observed in the phenomenon in which, in the portion where a skate blade passes on ice, heat is generated, causing the ice to melt and be slippery.

20 For example, when a frictional force is applied to a gas-liquid mixed fluid in which a gas such as oxygen is mixed with water, the bubbles included in the fluid are divided into small pieces after tensile deformation stretching the bubbles is generated, as illustrated in FIG. 1A. Each finely divided individual bubble is atomized over and over again and becomes extremely fine in nano size (hereinafter, referred to as "the principle of atomization of bubbles by friction").

25 The applicant of the present application has disclosed "Channel member for generating microbubbles using the principle of atomization of bubbles by friction" (Korean Patent No. 10-2100074) (hereinafter, referred to as "pre-registered technique").

30 The pre-registered technique is a technique capable of generating nanobubbles when a friction surface is densely formed on a tube-shaped flow path member and the friction length is several meters to several tens of meters long, wherein

nanobubbles are generated by causing the gas-liquid mixed fluid to rub against the stationary friction surface while moving at a pressure and a velocity equal to or higher than critical points.

5 The pre-registered technique is safe for generating nanobubble on a small and medium scale, but when it is necessary to output a large amount, a large-capacity pressure pump should be used instead of a general pump, and it is difficult to create a dense friction surface to correspond to the increasing diameter
10 of the tube.

 In order to solve the above-described problems, as a reverse idea of the pre-registered technique, the applicant of the present application conceived a method in which the fluid is in a stationary state and the friction surface applying a
15 frictional force to the fluid moves at high speed.

 It was considered that, in generating nanobubbles, the following phenomenon may occur: if fine bubbles were generated in the gas-liquid mixed fluid even if the fine bubbles were not atomized up to the microbubble level, when a rotating frictional
20 force is forcibly applied to the bubbles as illustrated in FIG. 1B, the bubbles included in the gas-liquid mixed fluid are tensioned and deformed in a circular arc shape along the rotating friction surface and finely divided, leading to an ultra-fine state.

25 The present disclosure applies the above-described rotating frictional force to the above-described principle of atomization of bubbles and generating nanobubbles using friction.

 As illustrated in FIGS. 2 and 3, a nanobubble generation
30 system 1A using friction according to a first embodiment of the present disclosure includes: a chamber 30 including an inlet 31, an outlet 32, and an internal space S configured to atomize bubbles included in a gas-liquid mixed fluid, the chamber 30

being provided with a driving shaft 41; at least one striker 20 including a plurality of protrusions 21 provided on a body thereof to simultaneously apply impact to the gas-liquid mixed fluid that flows into the chamber 30 and swirl the fluid in order to cause the gas-liquid mixed fluid to rub against an inner wall 33 of the chamber, the striker being provided on the driving shaft 41; a plurality of friction elements 10 provided on the driving shaft 41 in order to apply a frictional force to the gas-liquid mixed fluid; and a driving mechanism 40 including the driving shaft 41 and configured to rotate the striker 20 and the friction elements 10.

The friction elements 10 are arranged on the driving shaft 41 to be spaced apart from each other at a predetermined interval such that, when the driving shaft rotates, the gas-liquid mixed fluid rubs against the peripheral surfaces and opposite surfaces of the bodies of the friction elements perpendicular to the axis thereof and rubs against the inner wall 33 of the chamber 30 so that the bubbles included in the gas-liquid fluid undergo tensile deformation and atomization, the peripheral surfaces 11 of the bodies of the friction elements directly face the inner wall 33 of the chamber with a predetermined distance therebetween, at least one of the friction elements 10 has a line speed of 8 m/sec or more at a tip end of the body thereof in a direction orthogonal to the axis thereof, and

the at least one striker 20 and at least one of the plurality of friction elements 10 are provided with at least one of a distribution hole 14a or 24a and a cut-out passage 14b configured to guide a flow of the gas-liquid mixed fluid to a plane perpendicular to the axis.

The gas-liquid mixed fluid may be variously made as a mixed liquid in which water and air are mixed, a mixed liquid in which a liquid other than water and air are mixed, a mixed liquid in which water, air, and an additional gas, such as oxygen (O₂),

ozone (O₃), or hydrogen (H₂), are mixed, and a mixed oil in which an industrial oil and an additional gas, such as oxygen (O₂), ozone (O₃), or hydrogen (H₂) are mixed.

5 The gas-liquid mixed fluid may include tap water, groundwater, river water, fresh water, and the like containing bubbles generated in a water supply process.

10 As illustrated in FIGS. 5A and 5B, FIGS. 16A to 16C, and the like, when the strikers 20 rotates, the protrusions 21 arranged in a sawtooth shape or the like around the peripheries of the strikers apply an impact and a shear force to the bubbles included in the gas-liquid mixed fluid to atomize the bubbles to a micro size, and the friction elements 10 apply a frictional force to the bubbles atomized into the micro size by using the strikers, thereby causing the bubbles to undergo tensile
15 deformation and to be atomized to an ultra-fine nano-size.

The rotation operation of the strikers 20 and the friction elements 10, particularly the rotation operation of the strikers 20, strongly push the fluid to the inner wall 33 of the chamber by a centrifugal force so that a frictional force is applied to
20 the fluid by using the inner wall 33 of the chamber, and while the fluid passes through the spaces between the chamber inner wall 33 and the rotating body configured with the strikers 20 and the friction elements 10, a spirally flowing flow is generated (see FIG. 4).

25 Here, the centrifugal force acts in the chamber by the rotation of the strikers 20 and the friction elements 10 so that the flow is biased toward the inner wall 33 of the chamber. Thus, in particular, both surfaces 12 of each friction element 10 orthogonal to the axis may lose most of the fluid friction
30 function thereof.

The plurality of friction elements 10 are arranged to be spaced apart from each other so that when the driving shaft rotates, a flow in which the fluid spirally flows is generated

(see FIGS. 2 to 4), and, as illustrated in FIG. 1B, the bubbles included in the gas-liquid mixed fluid undergo tensile deformation in an arc shape on the peripheral surface 11 and the both surfaces 12 of each friction element 10 perpendicular to the axis, in particular, on the wide inner surface 33 of the chamber 30 to be finely divided and intensively atomized so that nanobubbles are generated.

At this time, as necessary conditions for generating nanobubbles, a sufficient friction surface, a line speed of the friction elements 10 for inducing a flow rate, and an appropriate distance between the friction elements 10 and the inner wall 33 of the chamber should be organically satisfied.

In the description of the friction element 10, "the peripheral surface 11 of the body directly faces the inner wall 33 of the chamber at a predetermined interval", the phrase "directly faces" means that, since there is no configuration between the friction element and the inner wall of the chamber, the inner wall of the chamber is fully exposed to the flow passage of the fluid, as illustrated in FIGS. 2 to 4 .

This also means that the stator provided on the inner wall of the chamber in the conventional techniques is excluded.

In addition, the distribution holes 14a or the cut-out passages 14b formed in each friction element 10 may prevent the flow on which a centrifugal force acts from being biased toward the inner wall 33 of the chamber and may enable the both surfaces 12 of each friction element 10 that are orthogonal to the axis, to function as friction surfaces (see FIGS. 2 to 4 and FIGS. 10A to 12C).

More specifically, the distribution holes 14a or the cut-out passages 14b formed in the friction elements 10 function as passages that allow the fluid to pass through the body of each friction element 10 and flow on both surfaces 12 orthogonal to the axis thereof in each body, whereby the distribution holes

14a or the cut-out passages 14b are capable of contributing to the expansion of an effective friction area of each friction element so that the fluid friction function can be performed even in an area close to the driving shaft 41 on both surfaces
5 12 orthogonal to the axis of the friction element.

In addition, since the distribution holes 14a or the cut-out passages 14b are formed in the friction elements 10, it is possible to amplify and accelerate the helical swirling flow of the fluid, thereby increasing the frictional force that affects
10 the atomization of bubbles.

Accordingly, the distribution holes 14a and the cut-out passages 14b formed in the friction elements 10 are preferably formed as large as possible at a position adjacent to the shaft holes 13 of the friction elements 10, but are not limited thereto
15 (see FIGS. 10A and 10B, etc.).

The cut-out passages 14b may be formed inward from the peripheral ends of the basic body (see FIG. 12A) having a disk shape, and may be formed to be directed to the center of the body (see FIGS. 11A and 12B). However, without being limited
20 thereto, the cut-out passages 14b may be formed in various ways, such as being inclined with respect to the radial direction.

The friction element 10 may be formed in a vane shape in which regions divided by the cut-out passages 14b are bent at an arbitrary angle (see FIG. 12C). The friction element having
25 this configuration has a friction function against the fluid, and is capable of accelerating or suppressing the flow rate depending on the arrangement direction together and suppressing the friction of the fluid from being biased to the inner wall of the chamber.

30 As illustrated in FIGS. 2 to 5B, a nanobubble generation system 1B using friction according to a first embodiment of the present disclosure includes: a chamber 30 including an inlet 31, an outlet 32, and an internal space S configured to atomize

bubbles included in a gas-liquid mixed fluid, the chamber 30 being provided with a driving shaft 41; at least one striker 20 including a plurality of protrusions 21 provided on a body thereof to simultaneously apply impact to the gas-liquid mixed fluid that flows into the chamber 30 and swirl the fluid in order to cause the gas-liquid mixed fluid to rub against the inner wall of the chamber 30, the striker being provided on the driving shaft 41; a plurality of friction elements 10 provided on the driving shaft 41 in order to apply a frictional force to the gas-liquid mixed fluid; and a driving mechanism 40 including the driving shaft 41 and configured to rotate the striker 20 and the friction elements 10.

The plurality of friction elements 20 are arranged on the driving shaft to be spaced apart from each other at a predetermined interval such that, when the driving shaft rotates, the gas-liquid mixed fluid rubs against the peripheral surfaces and opposite surfaces of the bodies of the friction elements perpendicular to the axis thereof and rubs against the inner wall of the chamber so that the bubbles included in the gas-liquid fluid undergo tensile deformation and atomization, the peripheral surfaces 11 of the bodies of the friction elements directly face the inner wall 33 of the chamber with a predetermined distance therebetween, and

at least one small-diameter friction element 10S and at least one large-diameter friction element 10L having a relatively large radius compared to the small-diameter friction element 10S are arranged to be spaced apart from each other at a predetermined interval.

Preferably, the small-diameter friction element 10S is disposed first in the fluid flow on the driving shaft, but the present disclosure is not limited thereto.

The small-diameter friction elements 10S and the large-diameter friction elements 10L may be alternately arranged.

In the nanobubble generation system 1B using friction of the second embodiment, in configuring and arranging the friction elements 10, the small-diameter friction elements 10S and the large-diameter friction elements 10L are arranged to be spaced
5 apart from each other at a predetermined interval, whereby, within a limited chamber space, it is possible to increase the spacing between the large-diameter friction elements 10L and to locate the small-diameter friction element 10S in the spacing, so that the friction space and friction area for the fluid can
10 be effectively used.

In addition, when only the friction elements 10 having the same radius are continuously arranged and the spacing between adjacent friction elements is not large, the fluid flow is biased toward the inner wall 33 of the chamber by a centrifugal force
15 as described above, and thus the both surfaces 12 of each friction element that are orthogonal to the axis thereof lose most of the utility thereof. However, when the friction elements are arranged to be jagged due to the radial differences, the entire surfaces of the bodies of the friction elements 10 are
20 capable of functioning as an effective friction surface even if the spacing between the friction elements 10 is not relatively large (see FIGS. 2 to 4, etc.).

Meanwhile, when the gas-liquid mixed fluid is atomized by applying a frictional force from the beginning without a
25 microbubble atomization step, the efficiency of the apparatus and the atomized quality of bubbles are deteriorated.

Therefore, as illustrated in FIGS. 4 and 5B, the driving shaft 41 of the first embodiment 1A and the second embodiment 1B may be sequentially provided with: a micro-atomization region S1
30 in which the one or more strikers 20 are arranged along the flow direction of the fluid in order to atomize the bubbles included in the gas-liquid mixed flowing into the chamber 30 to a microbubble level in advance; and a nano-atomization region S2

which is provided after the micro-atomization region S1 in the fluid flow and in which one or more friction elements 10 are arranged in order to ultra-atomize the atomized bubbles into nanobubbles.

5 One or more strikers 20 may be provided in the nano-atomization region S2 to generate a strong centrifugal force (see FIG. 4 etc.).

10 In addition, as illustrated in FIG. 5, a ring-shaped stator 60 installed on the inner wall of the chamber to face the striker 20 is provided in the micro-atomization region S1, and the stator 60 may be provided with a plurality of protrusions 61 around the ring-shaped inner surface thereof.

15 The micro-atomization region S1 is preferably formed in a short section of 1/3 or less of the nano-atomization region S2, but is not limited thereto.

As the number of strikers 20 increases, the helically swirling flow of the fluid becomes stronger, and accordingly, the flow resistance increases and the ejection amount decreases.

20 According to the above-described configuration, the gas-liquid mixed fluid introduced through the inlet 31 of the chamber at a predetermined set flow rate is atomized to a microbubble level in advance by an impact and a shear force applied thereto by the strikers 20 in the micro-atomization region S1 including the strikers 20 and the inner wall 33 of the chamber adjacent to the same, and in the subsequent helical swirling flow, tensile deformation and ultra-atomization by friction are strengthened step by step in the nano-atomization region S2 including the friction element 10 and the inner wall 33 of the chamber adjacent to the same, so that nanobubbles can be effectively generated.

30 Meanwhile, as described above, when the micro-atomization region S1 and the nano-atomization region S2 are driven by using a single driving mechanism in a single chamber and the scales of the regions are increased, there is a problem in that the driving

mechanism is overloaded.

In consideration this point, in a nanobubble generation system 1C using friction according to a third embodiment, a micro-level atomization apparatus 20A(20B) using a striker 20 and a nanobubble generation apparatus 10A using a friction element 10 are separated into independent apparatuses that include separate chambers and driving mechanisms, respectively, to distribute the driving load, and the gas-liquid mixed fluid is introduced into the nanobubble generation apparatus 10A after first passing through the micro-level atomization apparatus 20A (20B) (see FIG. 6).

As illustrated in FIGS. 6 to 9, the nanobubble generation system 1C using friction according to the third embodiment includes one or more micro-level atomization apparatuses 20A (20B) that apply an impact and a shear force to the gas-liquid mixed fluid to atomize bubbles to a micro-level, and a nanobubble generation apparatus 10A that atomizes bubbles into nanobubbles by applying a frictional force to the gas-liquid mixed fluid passing through the micro-level atomization apparatus 20A (20B).

As illustrated in FIGS. 7A to 8, the nanobubble generation apparatus 10A includes: a first chamber 30A including an inner wall 33 defining a space S for accommodating the gas-liquid mixed fluid and configured to apply a frictional force to the fluid, an fluid inlet 31 and a fluid outlet 32; one or more friction elements 10 provided in the first chamber 30A to be rotatable by using the driving shaft 41 and configured to generate a centrifugal force to push the fluid to the inner wall and function as a friction mechanism for the fluid by itself; and a first driving mechanism 40A including the driving shaft 41 for rotating the friction element 10.

As illustrated in FIGS. 9A and 9B, the micro-level atomization apparatus 20A includes a second chamber 30B including an internal space S for atomizing the bubbles included

in the gas-liquid mixed fluid, an inlet 31, and an outlet 32, the second chamber being provided with a driving shaft 41; one or more strikers 20 or impellers 20f provided on the driving shaft 41 and each provided with a plurality of protrusions 21 configured to apply an impact to the fluid; and a second driving mechanism 40B including the driving shaft 41 and configured to drive the strikers 20 or impellers 20f.

In the micro-level atomization apparatus 20A, when the strikers 20 rotate, the protrusions 21 arranged on the peripheries thereof in a sawtooth shape or the like apply an impact and a shear force to the bubbles included in the gas-liquid mixed fluid to atomize the bubbles to a micro-size in preparation of efficient generation of nanobubbles that is to be performed subsequently.

In the second embodiment (1B) and the third embodiment (1C), as in the case of the first embodiment (1A), at least one of the friction element 10 and the striker 20 may be provided with at least one of the distribution holes 14a (24a) and the cut-out passages 14b for guiding the flow of the gas-liquid mixed fluid to a plane perpendicular to the axis.

In the second embodiment (1B) and the third embodiment (1C), as in the first embodiment (1A), it is preferable for at least one of the friction elements 10 to have a linear speed of 8 m/sec or more at the tip-most end of the body thereof in the direction orthogonal to the axis thereof.

In addition, in the first embodiment (1A), the second embodiment (1B), and the third embodiment (1C), a distance I between a tip end of a surface of at least one of the friction elements 10 orthogonal to the axis thereof and the inner wall 33 of the chamber may be set to be equal to or less than 1/2 of the radius of the friction element in order to apply a frictional force to the gas-liquid mixed fluid by using the inner wall 33 of the chamber (see FIGS. 3A to and 7C).

The linear speed and the distance I are set based on that having the largest radius among the friction elements 10.

In addition, among the friction elements 10, the friction element disposed closest to the outlet 32 of the chamber may have an inclined surface 17 at the edge of the peripheral surface of the body thereof facing the outlet of the chamber (see FIGS. 2, 4 and 8).

As described above, the configuration in which the edge of the friction element 10 is formed in the inclined surface 17 toward the outlet delays the separation point of the fluid, thereby increasing frictional efficiency.

In addition, at least one of the plurality of friction elements 10 may have an annular or spiral groove 16 formed on the peripheral surface 11 of a disk-shaped body (see FIGS. 13A and 13B).

The groove 16 formed in the peripheral surface 11 of the friction element may increase the friction area for the fluid.

In addition, at least one of the friction element 10 and the striker 20 may include one or more concave stages 15 formed on at least one of both surfaces 12 orthogonal to the axis of the body thereof in order to increase the friction area (see FIGS. 13A and 13B).

In addition, in at least one of the friction element 10 and the striker 20, fine irregularities may be formed on at least a portion of the surface of the body thereof in order to increase the friction area (not illustrated), wherein the fine irregularities may be formed through various methods such as surface roughening, sandblasting, and scratching.

In addition, the friction element 10 or the striker 20 may be formed as a multi-friction element 10m or a multi-striker in which two or more bodies are integrated as a single body via a connecting portion 18 (see FIGS. 14A and 14B).

The multi-friction element 10m may be formed in two or

more stages, of which the disk-shaped bodies are different in radius.

In addition, the one or more friction elements 10 and the one or more strikers 20 may be formed as a single body (not
5 illustrated).

In addition, at least one of the friction elements 10 may be formed as an impeller-type friction element 10c having a plurality of vanes 112 (see FIGS. 15A to 15C).

The impeller-type friction element 10c may be formed in
10 various shapes such as a shape in which vanes 112 are provided between opposite surfaces orthogonal to the axis of the body thereof (see FIGS. 18A and 18B), and a shape in which one side surface is opened to expose blades to one side (see FIG. 15C).

The impeller-type friction element 10c may increase a
15 swirling flow rate, guide a fluid flow to the central portion so as to suppress the friction from being biased to the inner wall of the chamber, and increase the friction area.

In addition, at least one of the strikers 20 of the first embodiment (1A), the second embodiment (1B), and the third
20 embodiment (1C) may be provided with the protrusions 21 on at least one of the peripheral surface of the disk-shaped body and the both surfaces orthogonal to the axis (FIGS. 17A and 17B).

In addition, at least one of the strikers 20 may be provided with at least one concave stage 25 and a plurality of
25 distribution holes on at least one of both surfaces of the disk-shaped body orthogonal to the axis thereof, and at least one of the outer periphery of the body and the inner or outer periphery of the concave stage 25 may be provided with the plurality of protrusions 21 (see FIGS. 18A and 18B).

30 In at least one of the strikers 20, the protrusions may be configured as vane-shaped protrusions like vanes of a blower fan, and by this configuration, it is possible to increase the flow rate along with the original function of the striker (not

illustrated).

In addition, in the nanobubble generation apparatus 10A as well, as in the case of the second embodiment (2B), the friction elements 10 may be arranged on the driving shaft 41 to be spaced
5 apart from each other at a predetermined interval, wherein one or more small-diameter friction elements 10S and one or more large-diameter friction elements 10L having a relatively large radius compared to the small-diameter friction elements 10S may be arranged at a predetermined interval in a mixed form.

10 In addition, one or more strikers 20 of the micro-level atomization apparatus 20A may be provided on the driving shaft 41 of the nanobubble generation apparatus 10A together with the one or more friction elements 10 (see FIG. 8).

As described above, when the striker 20 having the
15 protrusions 21 around the body thereof is disposed in the nanobubble generation apparatus 10A, in particular, at the entrance of flow, the striker 20 applies an impact to the fluid and generates a strong centrifugal force to the fluid so that the frictional force can be strengthened by using the inner wall
20 33 of the first chamber.

In the micro-level atomization apparatus 20A, at least one of the strikers 20 may include the plurality of protrusions 21 formed at least around the periphery of the body, and the second chamber 30B may include a plurality of protrusions 37 formed
25 directly or indirectly on at least a portion of the inner wall 33 (see FIGS. 19A to 20).

When the protrusions 37 are formed on the inner wall of the chamber in the micro-level atomization apparatus 20A, the protrusions are capable of applying a strong impact and shear
30 force to the fluid together with the protrusions 21 of the striker.

In addition, the micro-level atomization apparatus may a pump type micro-level atomization apparatus 20B in which the

impeller 20f is provided on the driving shaft 41, the inlet of the impeller 20f is connected to the inlet of the chamber via an inlet pipe 31a, and protrusions 37 are radially formed on the inner wall 33 of the second chamber 30B (see FIGS. 21A and 21B and FIGS. 22A and 22B).

The protrusions 37 on the inner wall of the second chamber 30B may have a rib shape, but are not limited thereto.

In the pump-type micro-level atomization apparatus 20B, the fluid introduced through the impeller 20f collides with the inner wall 33 and the protrusions 37 of the second chamber, and at the same time, collision between the fluids occurs in the internal space of the second chamber and thus cavitation occurs. Accordingly, an impact and a shear force are applied to the fluid to generate microbubbles.

Between the impellers 20f of the pump-type micro-level atomization apparatus 20B and the inner wall 33 of the second chamber 30B, a volute-type duct 27 that sucks and guides the gas-liquid mixed fluid to the inner wall 33 of the second chamber may be provided (see FIGS. 22A and 22B).

When the volute-type duct 27 is provided between the impeller 20f and the inner wall 33 of the second chamber 30B as described above, the fluid is collected and collide with the inner wall 33b and the protrusions 37 of the second chamber, whereby the impact and shear force can be strengthened and more powerful cavitation can be generated.

As illustrated in FIG. 6, the nanobubble generation system 1C of the third embodiment having the above-described configuration may be arranged in various ways.

As an embodiment, a pump P, one micro-level atomization apparatus 20A (20B), and one nanobubble generation apparatus 10A may be sequentially connected and provided in the flow line of the gas-liquid mixed fluid (see FIG. 6A).

In addition, a plurality of micro-level atomization

apparatuses 20A (20B) may be provided in pairs with the pump P, and one nanobubble generation apparatus 10A may be connected after the plurality of micro-level atomization apparatuses 20A (20B) so that the fluid ejected from the plurality of micro-level atomization apparatuses 20A (20B) can be collected to and processed through the one nanobubble generation apparatus 10A (see FIG. 6B).

In addition, a pump P and a plurality of micro-level atomization apparatuses 20A (20B) may be provided in series in the flow line of the gas-liquid mixed fluid, and thereafter, the nanobubble generation apparatus 10A may be sequentially connected and installed (FIGS. 6C and 6D).

In addition, when a large amount of gas such as oxygen is injected at once in the flow line of the gas-liquid mixed fluid, an overflow phenomenon occurs due to temporary supersaturation of the gas.

In an embodiment of the present disclosure, gas injection may be performed at a plurality of locations in the fluid flow line, and thus, it is possible to enhance the nanobubble generation efficiency by causing the gas-liquid mixed fluid to contain a large amount of gas while preventing the overflow of the gas due to supersaturation (see FIG. 6C).

In addition, the pumps P involved in the above-described embodiments (see FIG. 6A to 6D) may be excluded (see FIG. 6E).

For example, when the micro-level atomization apparatus is of a pump type 20B or the striker includes vane type protrusions 21a, the pump P may be excluded.

As described above, in the nanobubble generation system 1C according to the third embodiment of the present disclosure, each of the micro-level atomization apparatus 20A (20B) and the nanobubble generation apparatus 10A includes a separate chamber and driving mechanism to be independently operated, whereby bubbles can be atomized stepwise so that nanobubbles can be

efficiently and the driving load can be dispersed even in a large-capacity nanobubble generation system so that the nanobubble generation system can be operated without any difficulty.

5 As illustrated in FIGS. 23 to 24B, a nanobubble generation system 1D using friction according to a fourth embodiment of the present disclosure includes: a chamber 30 including an inlet 31, an outlet 32, and an internal space S configured to atomize
10 bubbles included in a gas-liquid mixed fluid, the chamber 30 is provided with the driving shaft 41; one or more striking/friction elements 12b each including a plurality of protrusions 11b configured to apply impact to the gas-liquid mixed fluid introduced into the chamber 30 and swirl the fluid to rub against the inner wall 33 of the chamber, and a friction portion 12b
15 configured to apply a frictional force to the fluid, the striking/friction elements 10b being provided on the driving shaft 41; and a driving mechanism 40 including the driving shaft 41 and configured to rotate the striking/friction elements 10b, wherein the striking/friction elements 10b are arranged on
20 the driving shaft 41 to be spaced apart from each other at a predetermined interval, and the peripheral surfaces of the bodies of the striking/friction elements directly face the inner wall 33 of the chamber with a predetermined distance I therebetween.

25 The friction portions 12b in the striking/friction element 10b are surfaces orthogonal to the axis of the striking/friction element, and as in the case of the above-described friction element, the fluid rubs against the friction portions when the striking/friction element rotates.

30 The striking/friction element 10b provides an impact and friction at the same time, and during rotation, the protrusions 11b formed on the body apply an impact and shear force to the bubbles included in the gas-liquid mixed fluid to atomize the

bubbles into microbubbles, and the friction portion 12b applies a strong friction to the bubbles atomized into the microbubbles, whereby the microbubbles undergo tensile deformation and ultra-atomization again so that nanobubbles are generated.

5 During the rotation operation of the striking/friction element 10b, in particular, the protrusions 11b generate a centrifugal force to strongly push the fluid to the inner wall 33 of the chamber, so that while a frictional force is applied to the fluid by using the inner wall 33 of the chamber, the gas-
10 liquid mixed fluid crosses the spaces between the striking/friction element 10b and the inner wall 33 of the chamber to generate a spirally flowing flow (see FIGS. 23 to 24B).

 At least one of the striking/friction elements 10b may be
15 provided with at least one of a distribution hole 14a and a cut-out passage 14b configured to guide a flow of the gas-liquid mixed fluid to a plane perpendicular to the axis thereof.

 In addition, a plurality of striking/friction elements 10b may be arranged on the driving shaft 41 to be spaced apart from
20 each other at a predetermined interval, wherein the protruding sizes 11a of the protrusions 11b may be relatively gradually decreased according to the arrangement order thereof in the fluid flowing direction in order to sequentially atomize the bubbles included in the gas-liquid mixed fluid from the microbubble level
25 to the nanobubble level (see FIGS. 24A to 24B).

 The driving shaft of the fourth embodiment (1D) may be provided with the striking/friction elements 10b, while at least one friction element 10 may be provided at the rear portion of the driving shaft (not illustrated).

30 At least one of the striking/friction elements 10b may include the protrusions 11b formed on at least one of the peripheral surface of the body and both surfaces of the body orthogonal to the axis (not illustrated).

Preferably, the striking/friction element 10b also has a line speed of 8 m/sec or more, and the predetermined distance I from the inner wall 33 of the chamber is 1/2 or less of the radius of the striking/friction element.

5 The shaft holes 13 and 23 of the friction elements 10 and the strikers 20 may be formed in a polygonal shape or a keyway structure corresponding to the cross section of the driving shaft so that the friction elements and the strikes can be integrally rotated when the driving shaft 41 rotates (see FIGS. 3A and 3B,
10 FIGS. 5A and 5B, etc.).

In addition, the chamber 30, 30A, or 30B may be provided with a funnel portion 34 at the side of the outlet 32, and the outlet 32 may be formed following the funnel portion 34 on an extension line of the center line of the driving shaft provided
15 in the chamber (see FIG. 2 to 7C, etc.).

In the chamber, since the funnel portion 34 and the outlet 32 are formed on the extension line of the center line of the driving shaft 41, the fluid swirling around the inner wall 33 of the chamber is smoothly ejected, and mass ejection can be
20 performed smoothly even if the internal pressure of the chamber not is formed high.

In the chamber 30, 30A, or 30B, fine irregularities 35 may be formed on at least a portion of the inner wall 33 (see FIG. 2 and FIGS. 7A to 7C).

25 The fine irregularities 35 may be formed by scratches, sandblasted irregularities, or the like.

The fine irregularities 35 may be formed in the inflow region of the chamber, for example, as in the micro atomization region S1, to increase an impact and friction when the fluid
30 collides therewith, but is not limited thereto.

Meanwhile, the driving shaft 41 according to one of the first to fourth embodiment (1A) to (1D) of the present disclosure may be additionally provided with at least one impeller adjacent

to the inlet 31 of the chamber 30, 30A, or 30B (not illustrated).

When the impeller is provided in the chamber 30 in this way, the gas-liquid mixed fluid may be introduced into the chamber by self-priming.

5 Meanwhile, the injected gas such as oxygen (O₂), ozone (O₃), or hydrogen (H₂) is not wholly dissolved in the liquid in the process of passing through the chamber 30, and a large amount (usually about 40%) of the gas is discharged in an undissolved state. Thus, after being discharged from the chamber, the gas
10 scatters from the liquid and disappears into the air, causing a great loss.

In order to prevent such a loss, a gas collection tank for recovering and re-injecting the non-dissolved gas scattering from the gas-liquid mixed fluid may be provided and connected
15 via a pipe (not illustrated).

The operating states of the nanobubble generation systems 1A, 1B, 1C, and 1D using friction and including the above-described configurations according to the first to fourth embodiments of the present disclosure will be reviewed with
20 reference to Tables 1 and 2 below.

[Table 1]

Experiment 1

Class.	Line speed of friction element (m/sec)	Increment of DO (ppm)	I	Chamber entrance pressure (bar)	Nanobubble generation (visually confirmed through transmission of green laser beam after microbubbles disappear)
Example 1	17.0	10.3	1/2R	0.75 - 0.65	Beam scattered light due to nanobubbles is visible
Example 2	14.1	11.6	1/2R	0.75 - 0.65	Beam scattered light due to nanobubbles is visible
Example 3	11.3	10.5	1/2R	0.75 - 0.65	Beam scattered light due

					to nanobubbles is visible
Example 4	8.5	9.3	1/2R	0.75 - 0.65	Beam scattered light due to nanobubbles is visible
Example 5	7.06	7.8	1/2R	0.75 - 0.65	Invisible

[Table 2]

Experiment 2

Class.	Line speed of friction element (m/sec)	Increment of DO (ppm)	I	Chamber entrance pressure (bar)	Nanobubble generation (visually confirmed through transmission of green laser beam after microbubbles disappear)
Example 1	17.4	18.9	12/100R	0.9 - 0.8	Beam scattered light due to nanobubbles is visible
Example 2	13.9	17.8	12/100R	0.9 - 0.8	Beam scattered light due to nanobubbles is visible
Example 3	10.45	16.5	12/100R	0.9 - 0.8	Beam scattered light due to nanobubbles is visible
Example 4	8.7	15.8	12/100R	0.9 - 0.8	Beam scattered light due to nanobubbles is visible
Example 5	6.97	15.2	12/100R	0.9 - 0.8	Invisible

5

From Tables 1 and 2 above, "I" denotes the distance between the tip-most end of the friction element 10 and the inner wall 33 of the chamber in the direction perpendicular to the axis, "R" denotes the radius of the friction element 10, and all experimental examples were each carried out under the following conditions.

10

1. Sample: tap water (DO: 8.5 ppm)

2. Experimental temperature: 24±0.5°C

3. Injected gas and injection method: oxygen (O₂ 100%),
5 self-priming

4. DO measurement time: 20 seconds after ejection in the nanobubble generation system

5. Nanobubble generation determination method: After the experiment was conducted, the sample was collected, shaken for
10 5 seconds, stopped for 3 minutes, and after the elapse of time for the microbubbles to disappear, a green laser beam (wavelength 532 nm) was transmitted in a dark room, and the determination was made through visual observation.

15 Unlike microbubbles that have a milky color in water, nanobubbles are transparent, so it is impossible to identify whether nanobubbles are generated under normal lighting conditions. Therefore, after the sample was collected in a transparent container, a green laser beam with a short wavelength was transmitted in a dark room.

20 At this time, when the nanobubbles float in the water, the laser beam is scattered to generate light, and when the nanobubbles do not exist, no light is generated.

25 When the green laser beam was transmitted through the sample subjected to the above-described experimental process, scattered light beams closely arranged in the form of bands was visible, so it was identified that nanobubbles were generated.

30 As shown in the experimental tables of Tables 1 and 2, it is identified that the amount of dissolved oxygen (DO) increases as the line speed of the friction element is faster, and it was identified that under the condition that the line speeds of the friction elements are the same, compared to the increments of DO in the examples of Experiment 1 in which the distance I was set to be narrower, the increments of DO are better in the examples

of Experiment 2 in which the distance I between the tip-most end of the friction element in the axial direction and the inner wall of the first chamber was set to be wider.

5 In addition, the increase in DO was not necessarily proportional to the generation of nanobubbles.

10 It is determined that because the measurement of DO was made 20 seconds after ejection from the nanobubble generation apparatus was performed, the microbubbles, which disappear in 2 to 3 minutes after ejection, temporarily increased the level of DO.

The experimental results of the above examples are summarized below.

15 First, when the line speed of the friction element is at least 8 m/sec or more, microbubbles are rapidly ultra-atomized into ultra-fine nanobubbles.

20 In the examples in which the line speed of the friction element was reduced to 8 m/sec or less, it was identified that there was no significant nanobubble generation (Example 5 of Table 1 and Example 5 of Experiment 2) and that when the line speed increased to 8 m/sec or more, the generation of nanobubbles increased rapidly.

Setting the line speed of the friction element to 8 m/sec or more in various embodiments including the first embodiment (1A) is based on this experience.

25 Second, it is preferable to configure the distance I between the inner wall 33 of the chamber and the tip end of the surface orthogonal to the axis of the friction element 10 to be close to 1/2 or less of the friction element radius R ($I < 1/2R$) (see FIGS. 7B and 7C in comparison).

30 When the distance I between the tip end of the surface orthogonal to the axis of the friction element and the inner wall 33 of the chamber is set to be farther than 1/2 of the radius of the friction element ($I > 1/2R$) as in the examples of

Experiment 1 (see FIG. 7C), DO and nanobubble generation efficiency is markedly low compared to the case where the distance I is set as narrow as 12/100 of the radius R of the friction element 10 as in the examples of Experiment 2 (see FIG. 5 7B).

This phenomenon is caused because the centrifugal force and flow speed according to the rotation of the friction element 10 is gradually weakened before reaching the inner wall 33 of the chamber, so the frictional force using the inner wall of the 10 chamber is weakened, and it can be seen that, when the distance I is set as narrow as 1/2 or less as in the examples of Experiment 2, the increase in DO and generation of nanobubbles are efficiently achieved.

In addition, the plurality of friction elements 10 are 15 arranged to be spaced apart from each other so that when the driving shaft rotates, a flow in which the fluid spirally flows is generated (see FIGS. 4, 7A, and 8), and, as illustrated in FIG. 1B, the bubbles included in the gas-liquid mixed fluid undergo tensile deformation in an arc shape on the peripheral 20 surface 11 and the both surfaces 12 of each rotating friction element 10 perpendicular to the axis, in particular, on the wide inner wall 33 of the first chamber 30 (30A) to be finely divided and intensively atomized so that nanobubbles are generated.

At this time, as described above, as necessary conditions 25 for generating nanobubbles, a sufficient friction surface, a line speed of the friction elements 10 for inducing a flow rate, and an appropriate distance between the friction elements 10 and the inner wall 33 of the chamber should be organically satisfied.

In the foregoing, the inner wall 33 of the chamber directly 30 facing the friction element 10 refers to a surface against which the fluid rubs by a centrifugal force when the friction elements 10 and the strikers are rotated, and is not limited to the inner wall of the chamber 30 itself and includes the inner wall of a

separate component that is coupled to the inner wall of the chamber.

That is, the inner wall 33 of the chamber itself may be replaced by a separate component coupled to the inner wall of the chamber for any reason other than the inner wall of the chamber 30 itself.

A common feature in the configurations of the nanobubble generation systems 1A, 1B, 1C, and 1D using friction of the first to fourth embodiments of the present application is that a stator that is a main component of the conventional techniques is excluded from the nanobubble generation apparatus in which a friction element is installed.

When a stator is provided on the inner wall of the chamber, the inner wall of the chamber cannot be used as a friction surface, and accordingly, the flow of the gas-liquid mixed fluid is not smooth, so that a spirally swirling flow cannot be generated. Therefore, it is not possible to achieve a significant improvement in the atomization quality of nanobubbles by friction and the generation of a large amount of bubbles by providing a wider effective friction surface.

Incidentally, the present disclosure may be compared to a prior art technology of the following example.

The prior art generator includes a casing, a stator, and a rotor and is a mechanical apparatus that converts mechanical work into electrical energy.

Here, assuming that a technology significantly improved in acting effect is newly disclosed and the technology is capable of generating electric energy by using an organic configuration of a casing and a new rotator while excluding a stator based on a new technical idea, and capable of generating high-quality, large-capacity energy that could not be predicted in the prior art at a remarkably low cost, it is natural that this new technology should be recognized as having inventive step.

The present disclosure also has inventive step like the new generator technology exemplified above.

In the foregoing, preferred embodiments of the present disclosure have been described with reference to the accompanying drawings.

Here, the terms or words used in the present specification and claims should not be construed as being limited to conventional or dictionary meanings, but should be interpreted as meanings and concepts consistent with the technical spirit of the present disclosure. In addition, it shall be noted that because the embodiments described in the specification and the configurations illustrated in the drawings are merely illustrative embodiments of the present disclosure, and do not represent all the technical ideas of the present disclosure, there may be various equivalents and modifications that may replace the embodiments at the time of filing the present application.

[Industrial Applicability]

As it becomes possible to generate nanobubbles in a qualitatively and quantitatively favorable manner according to the present disclosure, nanobubbles excellent in utility can be easily used at a low cost, especially in the industrial field requiring a large amount of nanobubbles.

Claims

1. A nanobubble generation system using friction, the nanobubble generation system comprising:

5 a chamber including an inlet, an outlet, and an internal space configured to atomize bubbles included in a gas-liquid mixed fluid, the chamber being provided with a driving shaft;

one or more strikers each including a plurality of protrusions provided on a body thereof to simultaneously apply
10 impact to the gas-liquid mixed fluid that flows into the chamber and swirl the fluid in order to cause the gas-liquid mixed fluid to rub against an inner wall of the chamber, the strikers being provided on the driving shaft;

a plurality of friction elements provided on the driving
15 shaft in order to apply frictional force to the gas-liquid mixed fluid; and

a driving mechanism including the driving shaft and configured to rotate the strikers and the friction elements,

wherein the friction elements are arranged on the driving
20 shaft to be spaced apart from each other at a predetermined interval, and peripheral surfaces of bodies of the friction elements directly face the inner wall of the chamber with a predetermined distance therebetween,

at least one of the friction elements has a line speed of
25 8 m/sec or more at a tip end of the body thereof in a direction orthogonal to the axis thereof, and

the at least one striker and at least one of the plurality
of friction elements are provided with at least one of a
distribution hole or a cut-out passage configured to guide a
30 flow of the gas-liquid mixed fluid to a plane perpendicular to the axis thereof.

2. A nanobubble generation system using friction, the

nanobubble generation system comprising:

a chamber including an inlet, an outlet, and an internal space configured to atomize bubbles included in a gas-liquid mixed fluid, the chamber being provided with a driving shaft;

5 one or more strikers each including a plurality of protrusions provided on a body thereof to simultaneously apply impact to the gas-liquid mixed fluid that flows into the chamber and swirl the fluid in order to cause the gas-liquid mixed fluid to rub against an inner wall of the chamber, the strikers being
10 provided on the driving shaft;

a plurality of friction elements provided on the driving shaft in order to apply frictional force to the gas-liquid mixed fluid; and

a driving mechanism including the driving shaft and
15 configured to rotate the striking friction elements,

wherein the plurality of friction elements are arranged on the driving shaft to be spaced apart from each other at a predetermined interval,

the peripheral surfaces of the bodies of the friction
20 elements directly face the inner wall of the chamber with a predetermined distance therebetween, and

one or more small-diameter friction elements and one or more large-diameter friction elements having a relatively large radius compared to the small-diameter friction elements are
25 arranged to be spaced apart from each other at a predetermined interval.

3. The nanobubble generation system of claim 1 or claim 2, wherein the driving shaft is sequentially provided with:

30 a micro-atomization region in which the one or more strikers are arranged along the flow direction of the fluid in order to atomize the bubbles included in the gas-liquid mixed flowing into the chamber to a microbubble level in advance; and

a nano-atomization region which is provided after the micro-atomization region in the fluid flow and in which one or more friction elements are arranged in order to ultra-atomize the bubbles, which are atomized into a micro-level, into
5 nanobubbles.

4. The nanobubble generation system of claim 3, wherein the micro-atomization region may be provided with a ring-shaped stator on the inner wall of the chamber to face the strikers,
10 and

the stator is provided with a plurality of protrusion around a ring-shaped inner surface thereof.

5. A nanobubble generation system using friction, the
15 nanobubble generation system comprising:

one or more micro-level atomization apparatuses configured to apply an impact and a shear force to a gas-liquid fluid to atomize bubbles to a micro-level; and

a nanobubble generation apparatus configured to apply a
20 frictional force to the gas-liquid mixed fluid passing through the micro-level atomization apparatuses to atomize the bubbles into nanobubbles,

wherein the nanobubble generation apparatus includes:

a first chamber includes an inlet and an outlet for the
25 fluid and an inner wall that defines a space configured to accommodate the gas-liquid mixed fluid and apply a frictional force to the fluid;

one or more friction elements provided in the first chamber to be rotatable by using a driving shaft and configured to
30 function as a friction mechanism for the fluid that generate a centrifugal force to push the fluid to the inner wall; and

a first driving mechanism including the driving shaft in order to rotate the friction elements, and

wherein the micro-level atomization apparatus includes:

a second chamber including an inlet, an outlet, and an internal space configured to atomize the bubbles included in the gas-liquid mixed fluid, the second chamber being provided with a driving shaft;

one or more strikers or impellers provided on the driving shaft and each including a plurality of protrusions configured to apply an impact to the fluid; and

a second driving mechanism including the driving shaft and configured to drive the strikers or the impellers.

6. The nanobubble generation system of claim 2 or claim 5, wherein at least one of the friction elements and the strikers is provided with at least one of a distribution hole and a cut-out passage configured to guide a flow of the gas-liquid mixed fluid to a plane perpendicular to the axis thereof.

7. The nanobubble generation system of any one of claims 1, 2, and 5, wherein at least one of the friction elements is an impeller-type friction element including a plurality of vanes.

8. The nanobubble generation system of claim 5, wherein at least one of the strikers of the micro-level atomization apparatus is provided on the driving shaft of the nanobubble generation system together with the one or more friction elements.

9. The nanobubble generation system of claim 5, wherein, in the micro-level atomization apparatus,

at least one of the strikers may be provided with a plurality of protrusions on at least the periphery of the body thereof, and

the second chamber is provided with a plurality of

protrusions directly or indirectly on at least a portion of an inner wall thereof.

10. The nanobubble generation system of claim 5, wherein
5 the micro-level atomization apparatus may be provided with the impeller on the driving shaft,

an inlet of the impeller may be connected to the inlet of the chamber via an inlet pipe, and

10 the micro-level atomization apparatus is a pump-type micro-level atomization apparatus in which protrusions are radially formed on the inner wall of the second chamber.

11. The nanobubble generation system of claim 10, wherein, between the impeller of the pump-type micro-stage
15 atomization apparatus and the inner wall of the second chamber, volute-type duct configured to suck and guide the gas-liquid mixed fluid to the inner wall of the second chamber is provided.

12. A nanobubble generation system using friction, the
20 nanobubble generation system comprising:

a chamber including an inlet, an outlet, and an internal space configured to atomize bubbles included in a gas-liquid mixed fluid, the chamber being provided with a driving shaft;

25 one or more striking/friction elements each including a plurality of protrusions configured to apply impact to the gas-liquid mixed fluid introduced into the chamber and swirl the fluid to rub against the inner wall of the chamber, and a friction portion configured to apply a frictional force to the fluid, the striking/friction elements being provided on the
30 driving shaft; and

a driving mechanism including the driving shaft and configured to rotate the striking/friction elements,

wherein the striking/friction elements are arranged on the

driving shaft to be spaced apart from each other at a predetermined interval, and peripheral surfaces of bodies of the striking/friction elements directly face the inner wall of the chamber with a predetermined distance I therebetween.

5

13. The nanobubble generation system of claim 12, wherein at least one of the striking/friction elements is provided with at least one of a distribution hole and a cut-out passage configured to guide a flow of the gas-liquid mixed fluid
10 to a plane perpendicular to the axis thereof.

FIG. 1

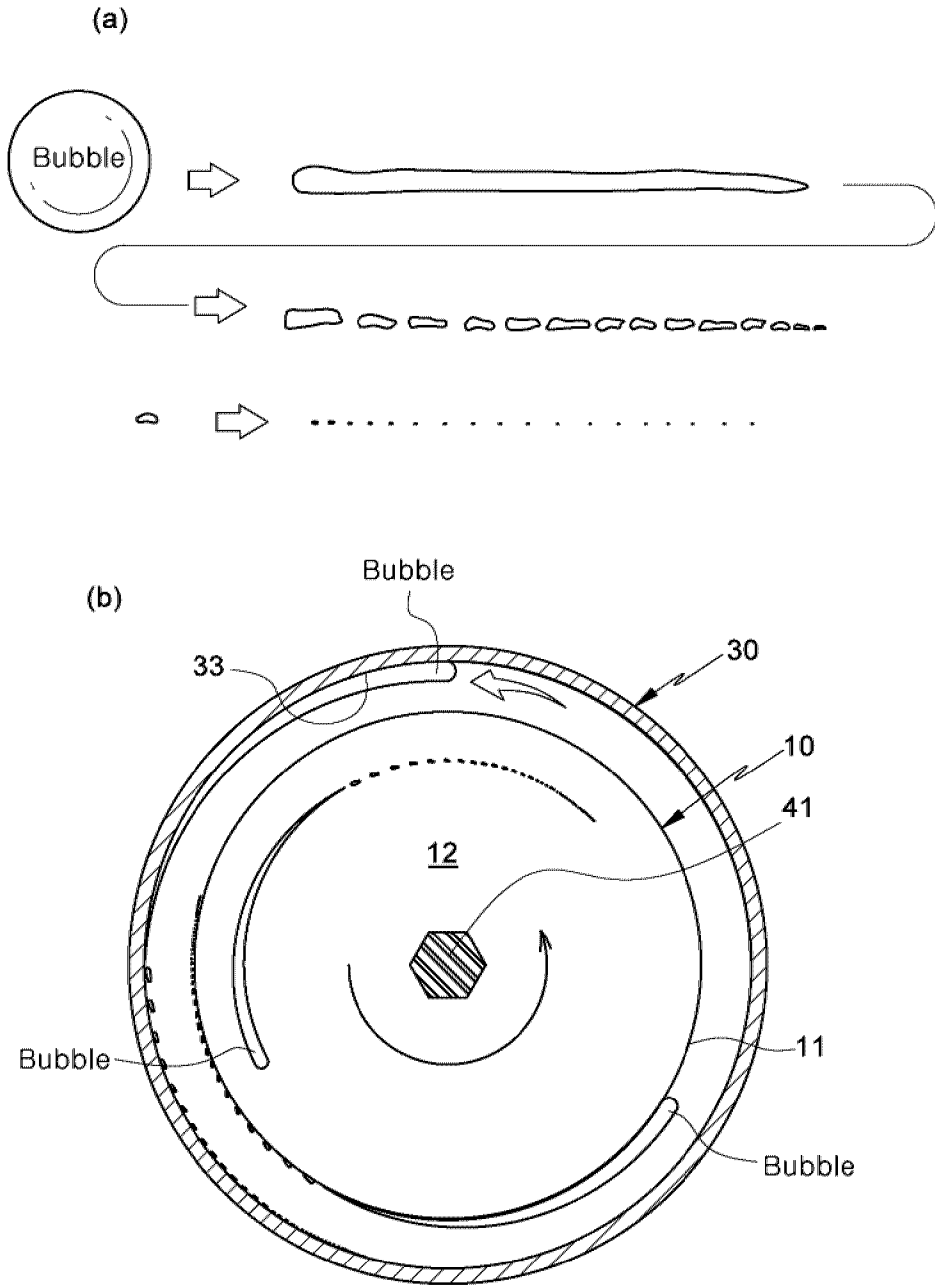

FIG. 3

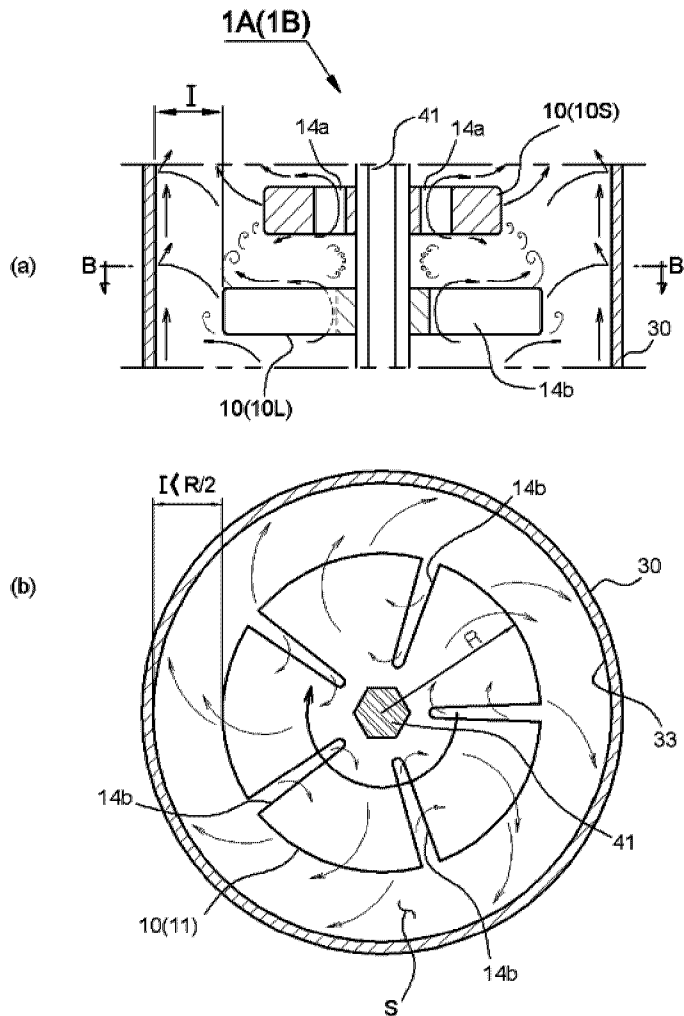

FIG. 4

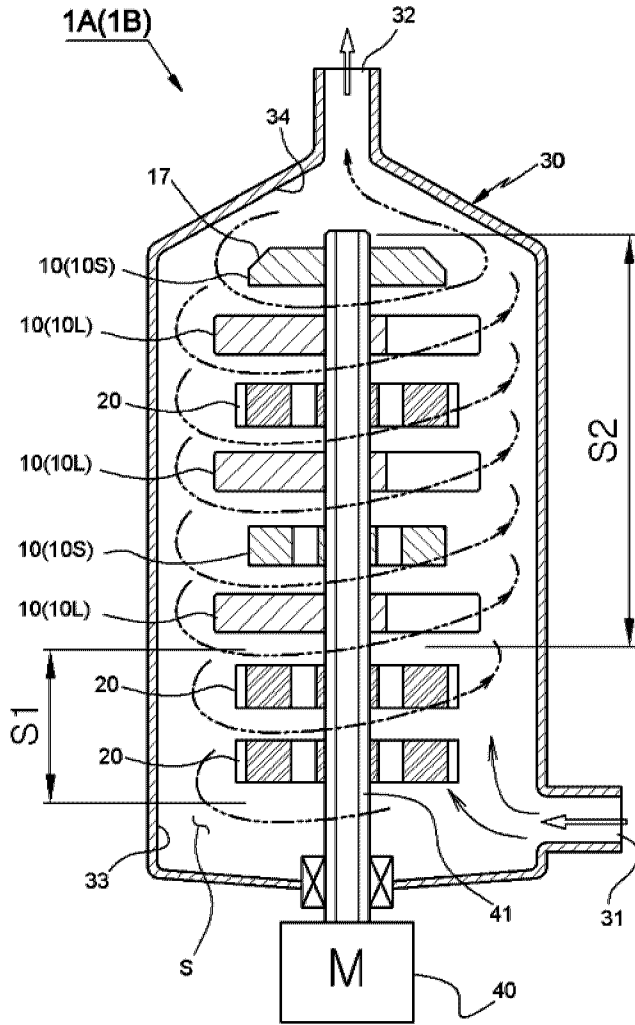

FIG. 5

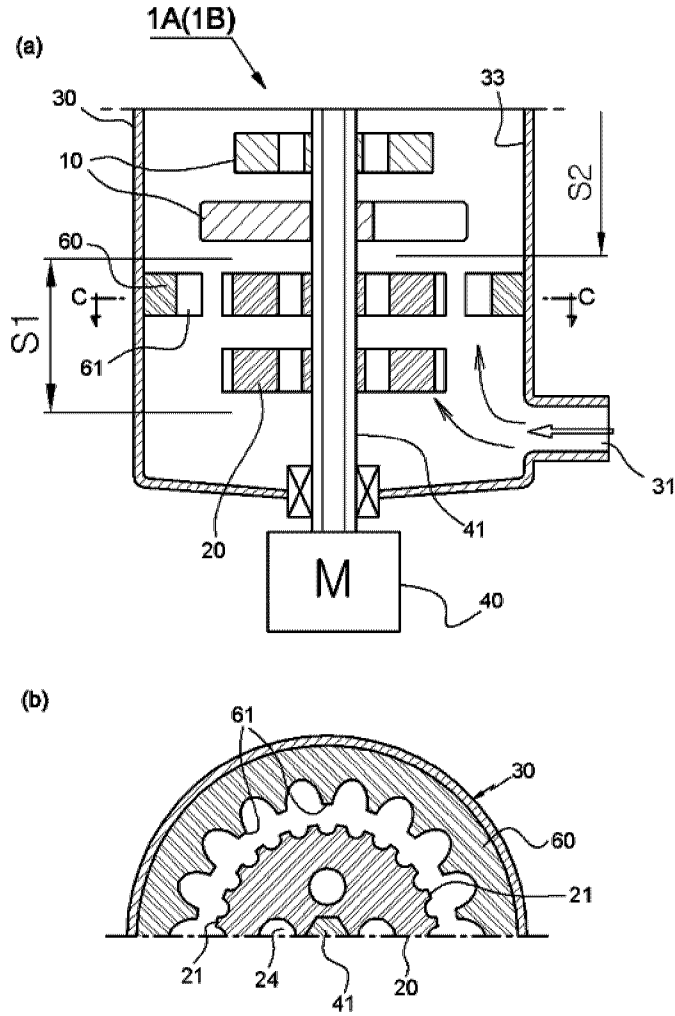

FIG. 6

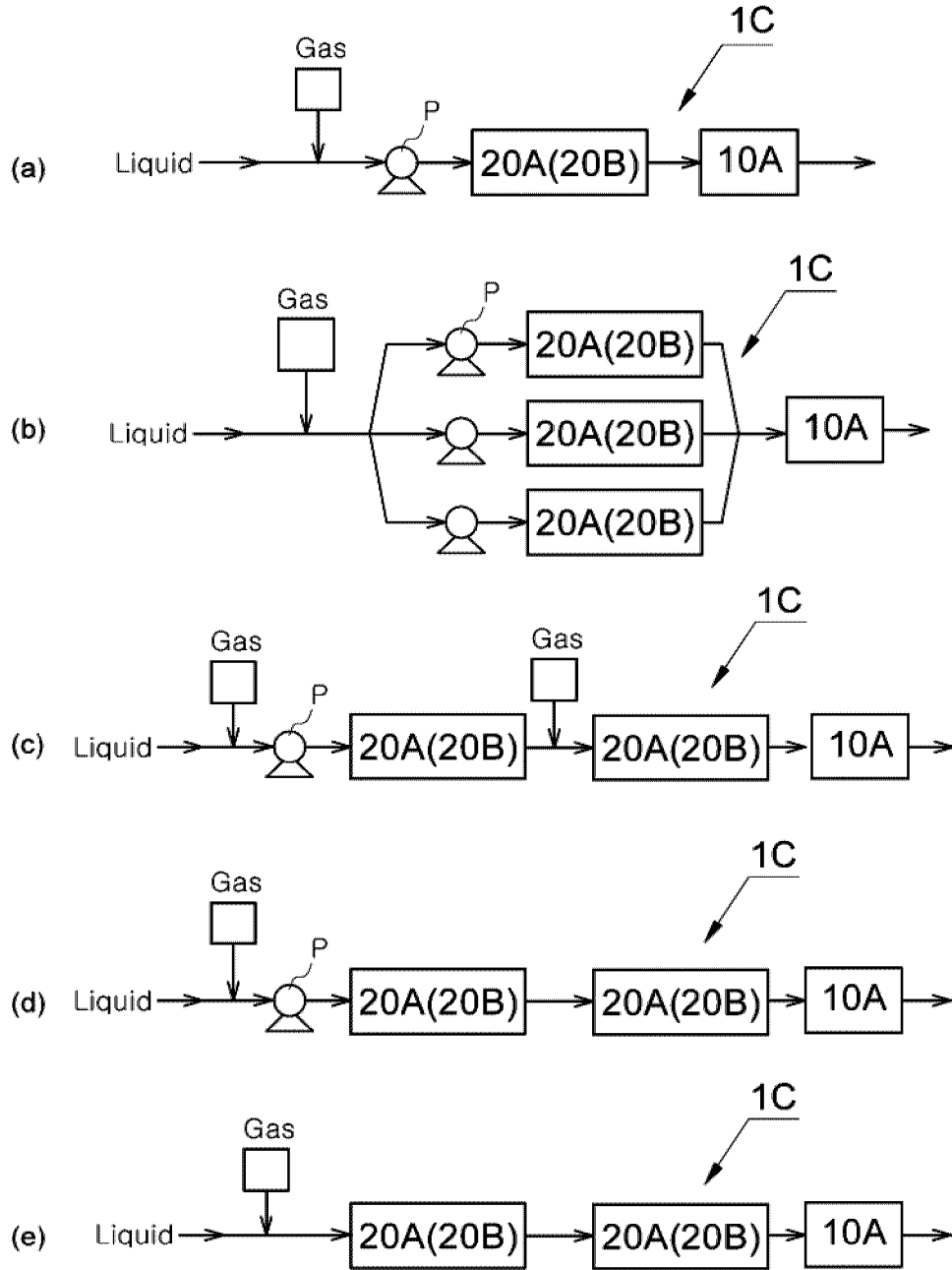

FIG. 7

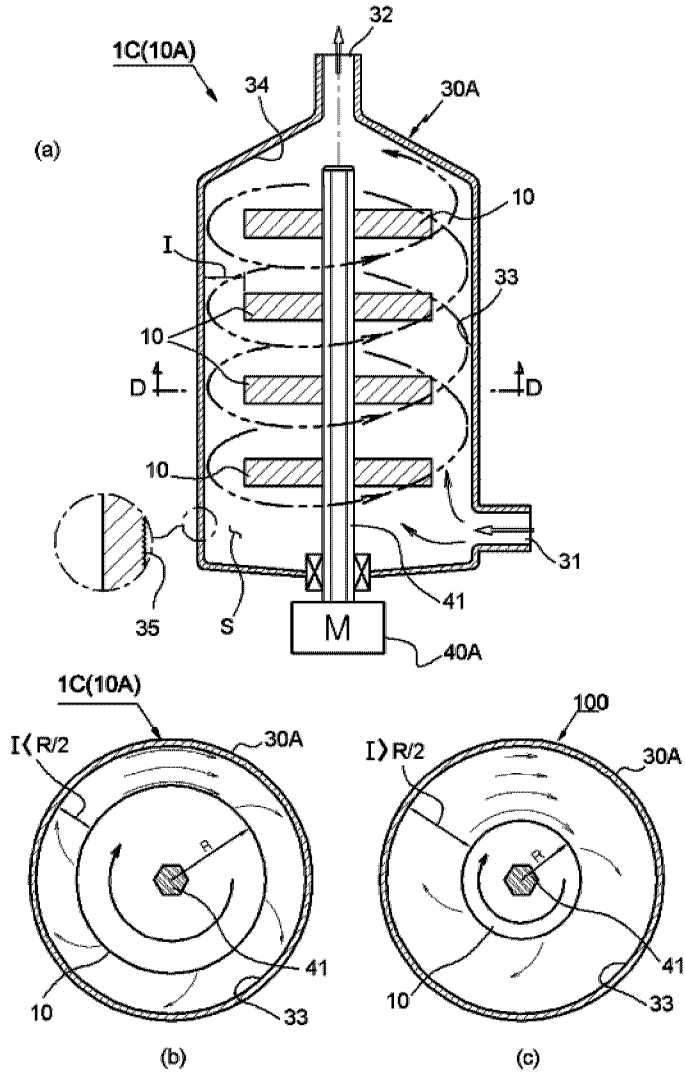

FIG. 8

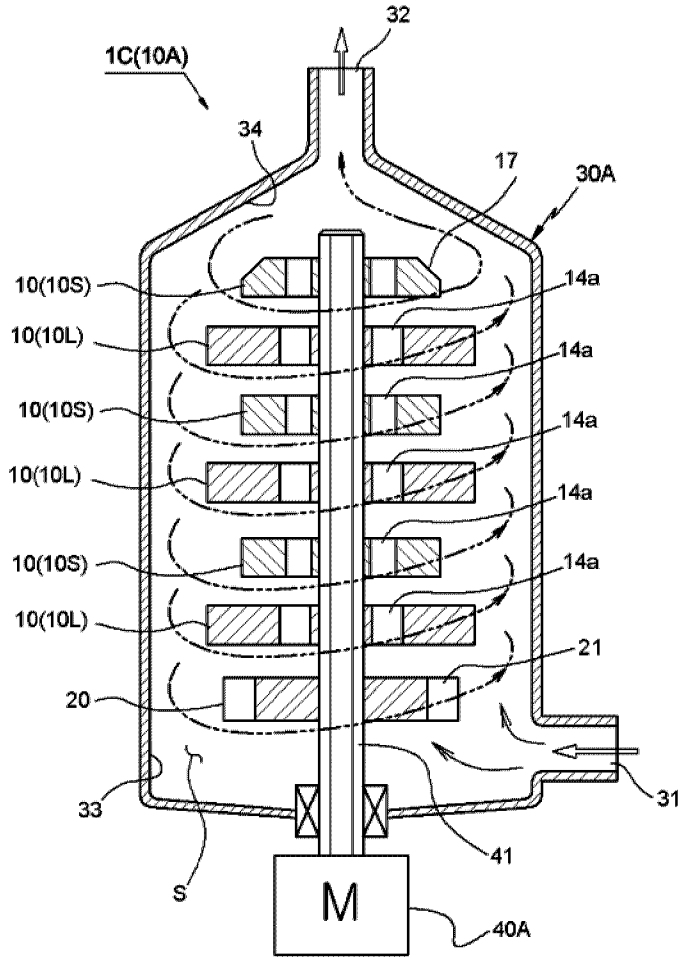

FIG. 9

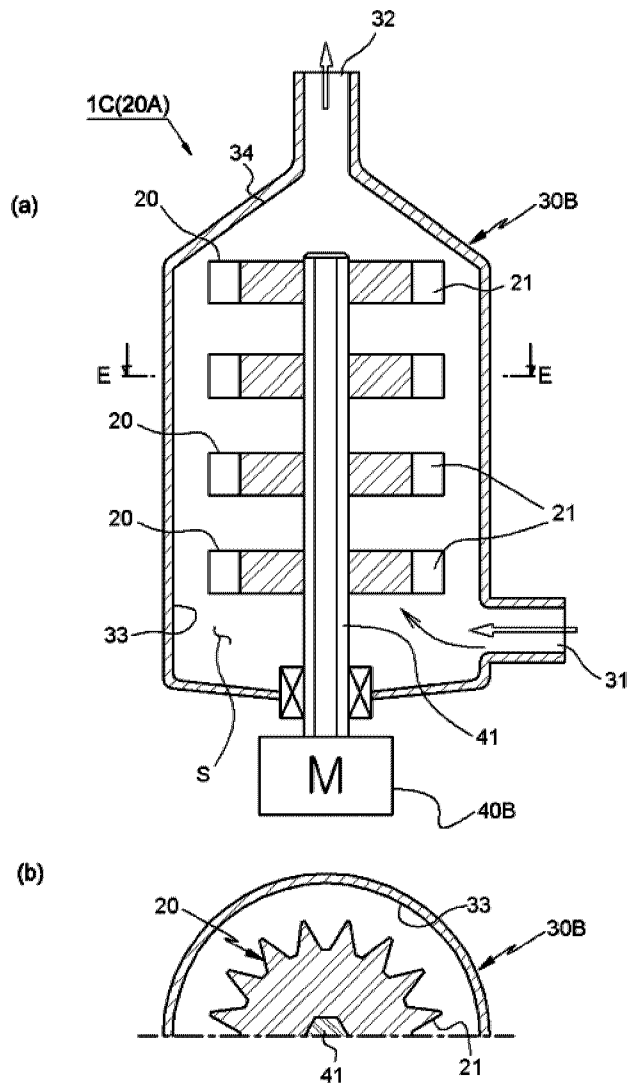
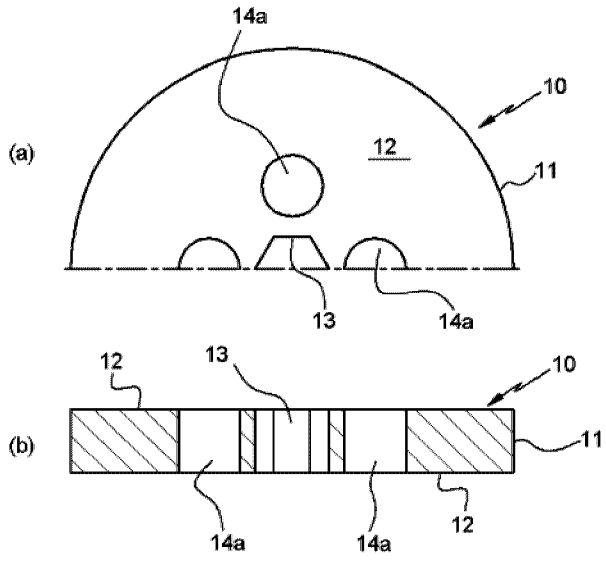

FIG. 10



5

FIG. 11

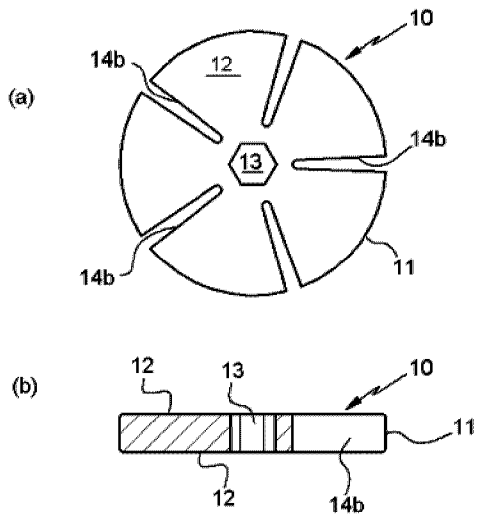

FIG. 12

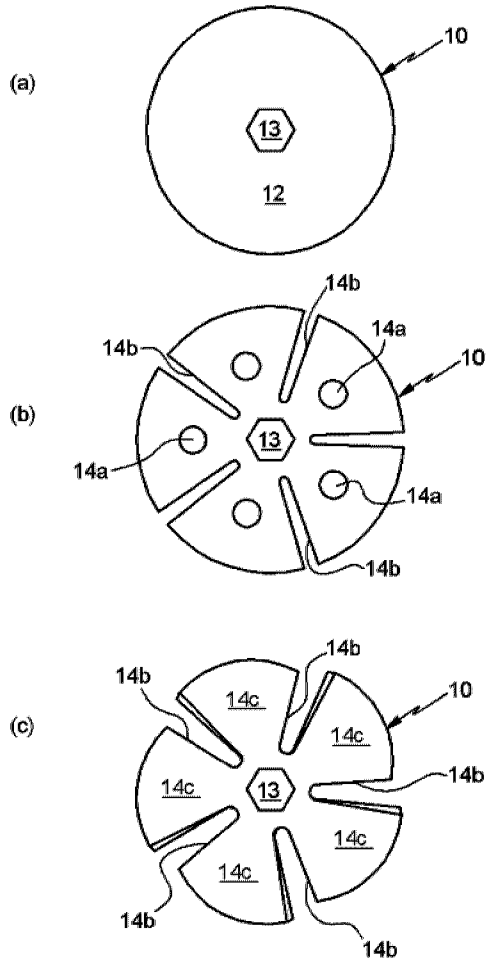

FIG. 13

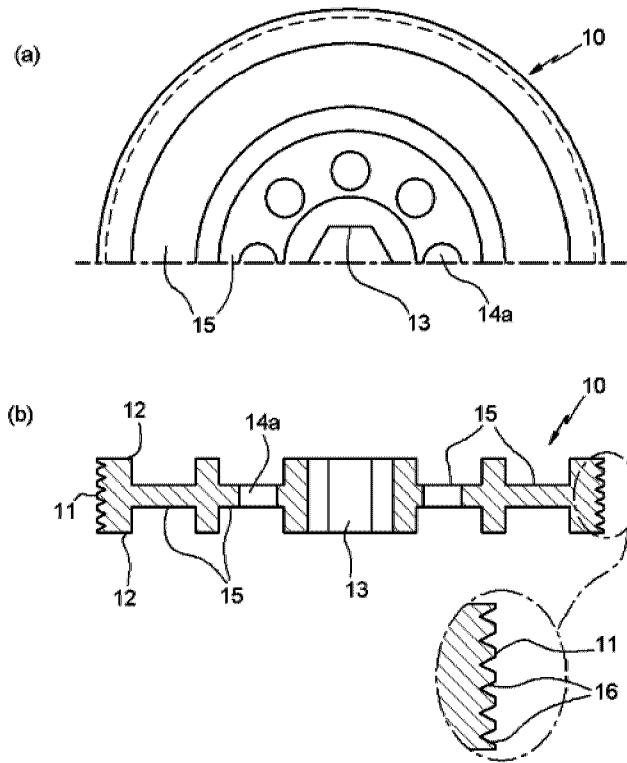

FIG. 14

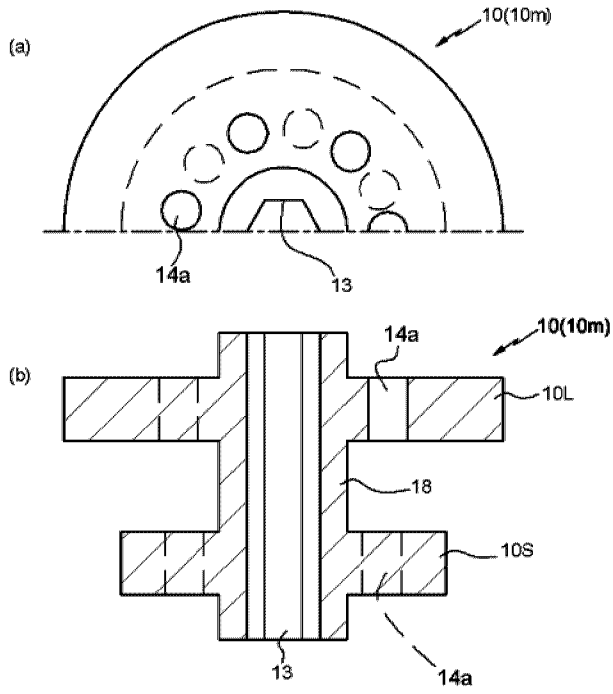
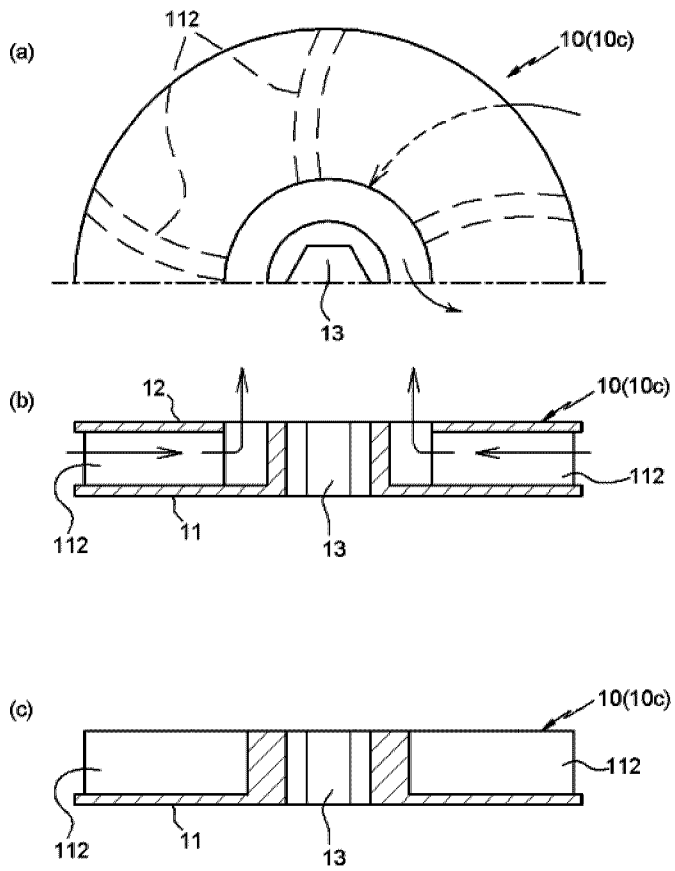

FIG. 15



15/22

FIG. 16

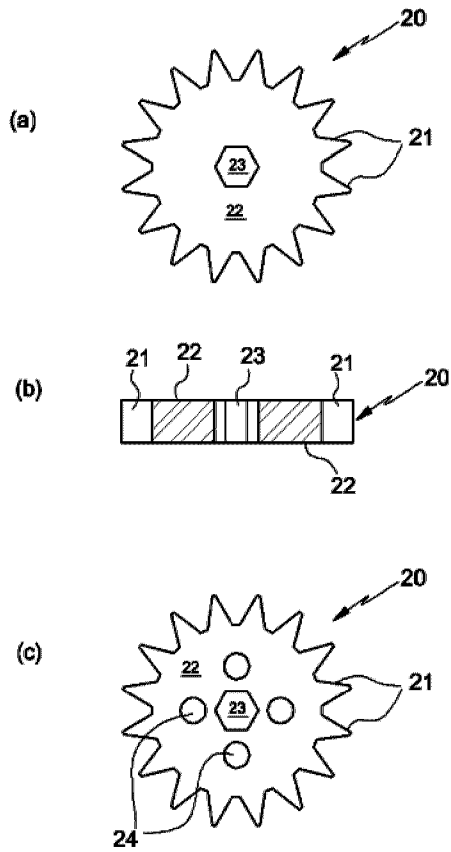
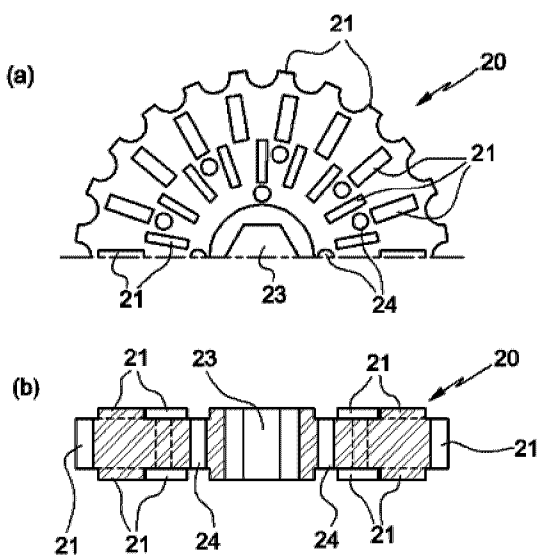

FIG. 17



5

FIG. 18

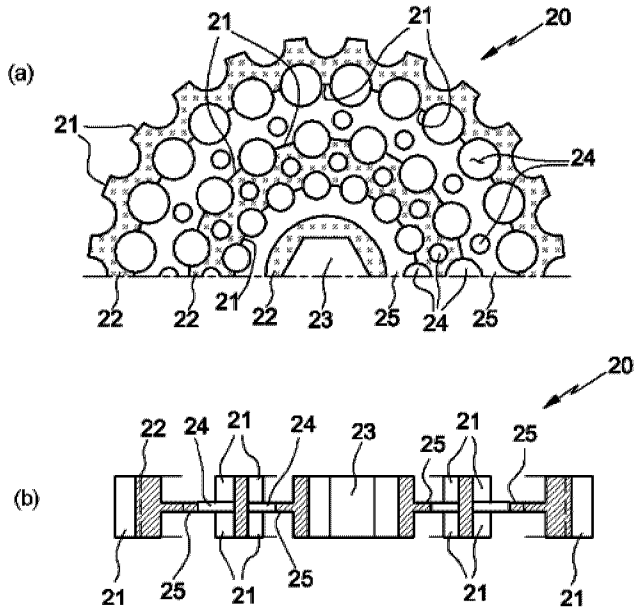

FIG. 19

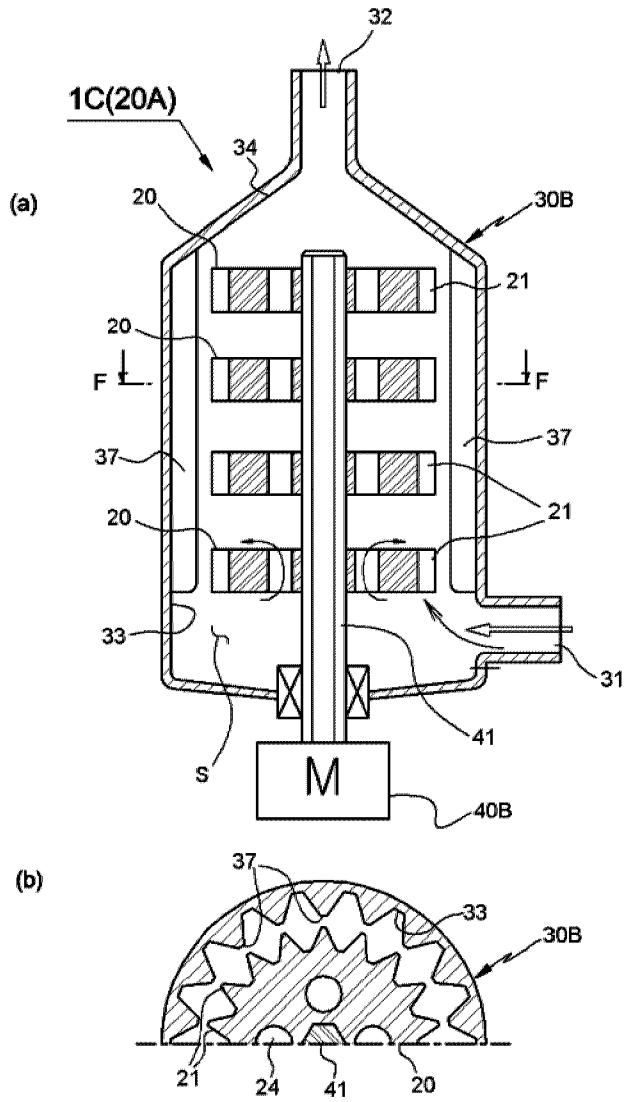

FIG. 20

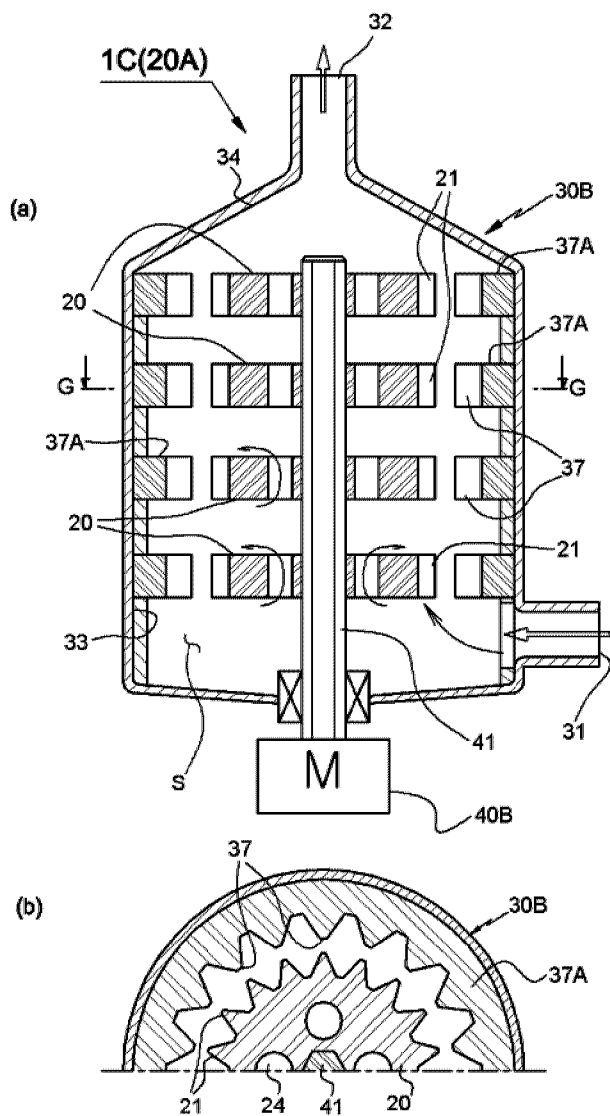

FIG. 21

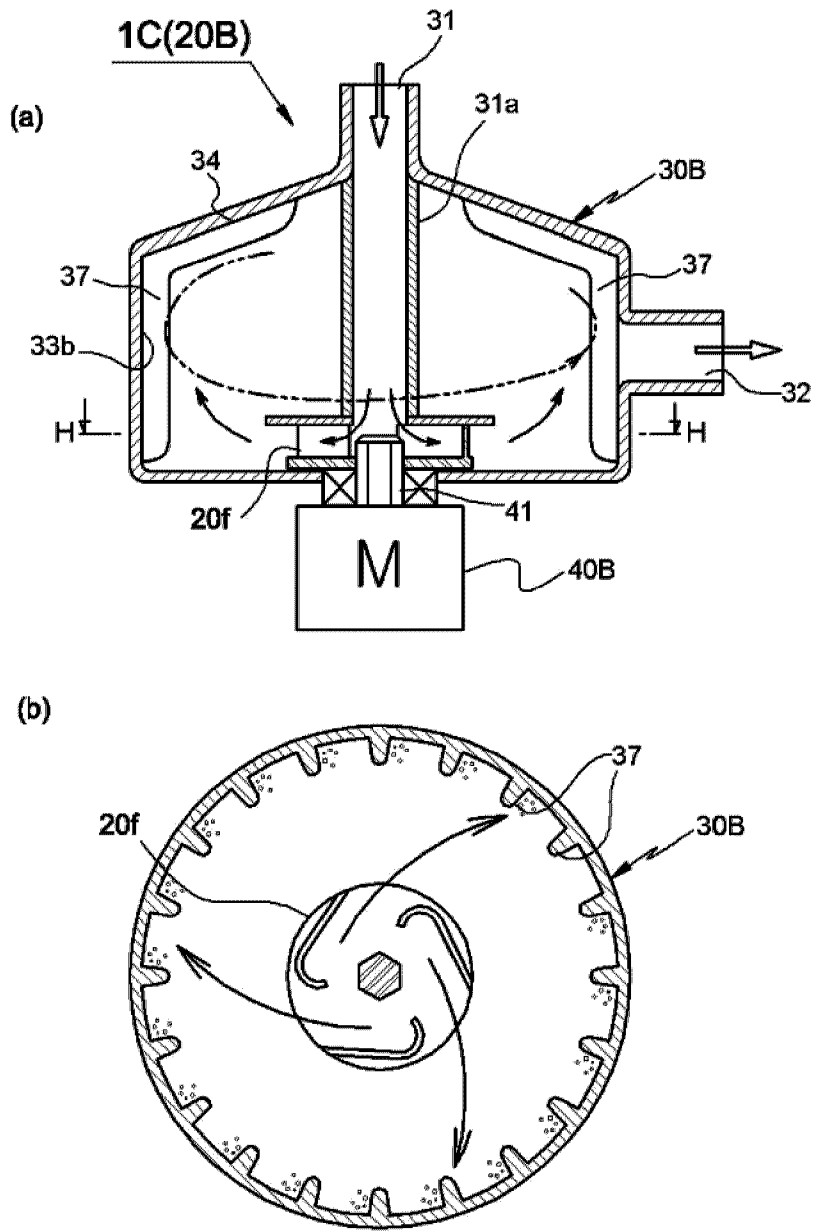

FIG. 22

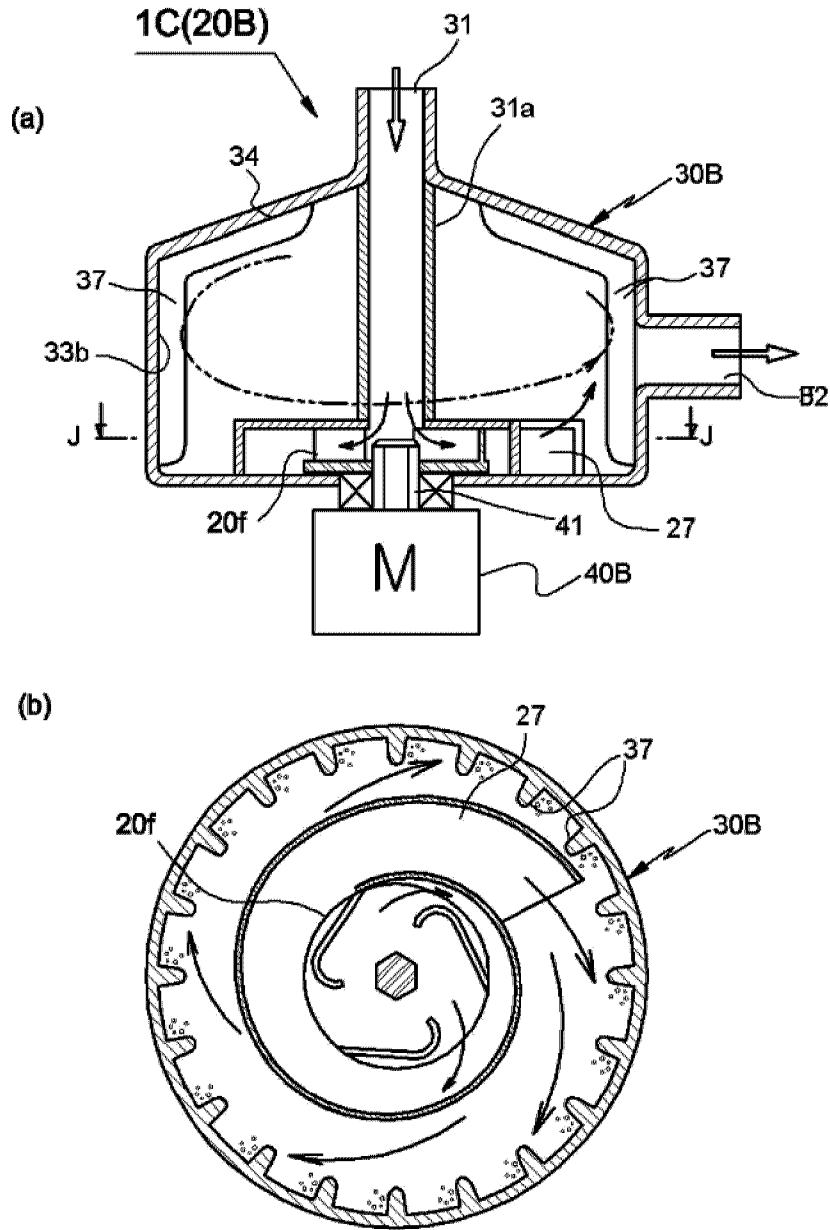

FIG. 23

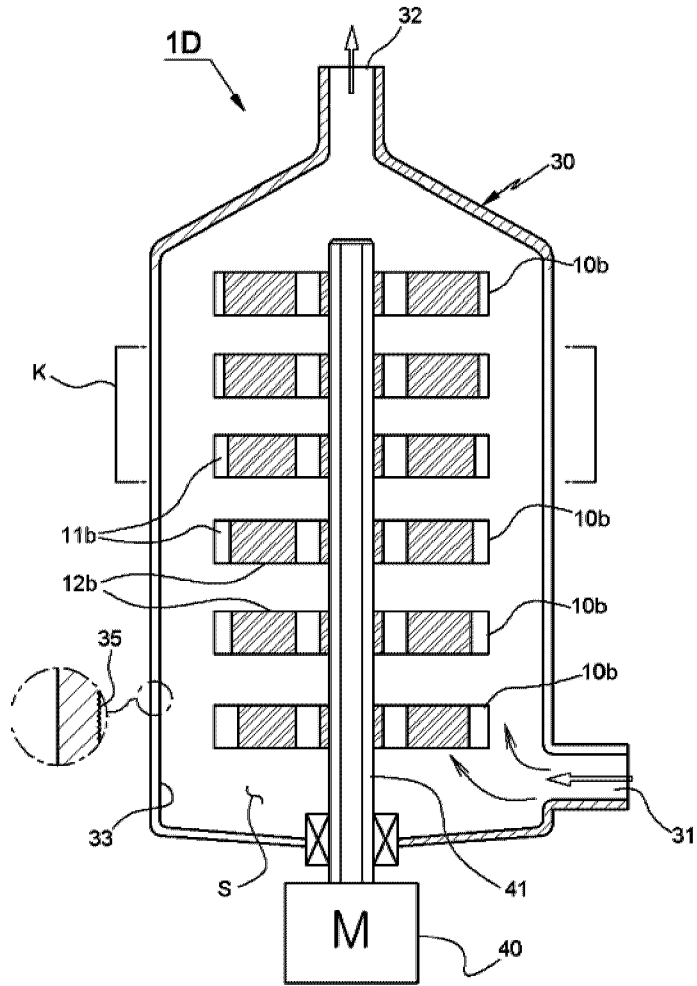

FIG. 24

