



(11) **EP 2 474 778 A1**

(12) **EUROPEAN PATENT APPLICATION**
published in accordance with Art. 153(4) EPC

(43) Date of publication:
11.07.2012 Bulletin 2012/28

(51) Int Cl.:
F21S 8/10 (2006.01) F21W 101/10 (2006.01)
F21Y 101/02 (2006.01)

(21) Application number: **10813472.7**

(86) International application number:
PCT/JP2010/005244

(22) Date of filing: **25.08.2010**

(87) International publication number:
WO 2011/027517 (10.03.2011 Gazette 2011/10)

(84) Designated Contracting States:
AL AT BE BG CH CY CZ DE DK EE ES FI FR GB GR HR HU IE IS IT LI LT LU LV MC MK MT NL NO PL PT RO SE SI SK SM TR

- **SUZUKI, Tetsuya**
Shizuoka-shi
Shizuoka 424-8764 (JP)
- **NAKAGAWA, Tomoyuki**
Shizuoka-shi
Shizuoka 424-8764 (JP)

(30) Priority: **03.09.2009 JP 2009203909**

(71) Applicant: **Koito Manufacturing Co., Ltd.**
Tokyo 108-8711 (JP)

(74) Representative: **Neobard, William John et al**
Kilburn & Strode
20 Red Lion Street
London WC1R 4PJ (GB)

(72) Inventors:
• **MATSUMOTO, Akihiro**
Shizuoka-shi
Shizuoka 424-8764 (JP)

(54) **VEHICLE HEADLIGHT**

(57) An automotive headlamp (10) is provided with: a light-emitting module (26); a control circuit unit (106) configured to control the lighting of the light-emitting module (26); a support substrate configured to support both the light-emitting module (26) and the control circuit unit (106); and a reflector (28) configured to reflect, through an inner surface of the reflector (28), light emitted by the light-emitting module (26) and collect the reflected light. The support substrate is arranged in a manner such that the control circuit unit (106) is positioned in a region outside the reflector (28).

[Figure 8]

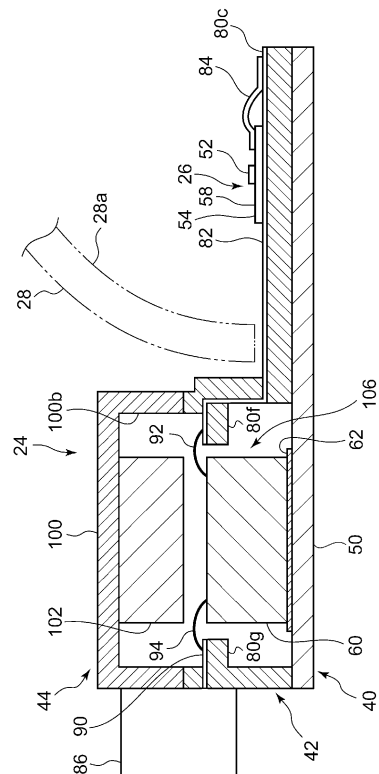

EP 2 474 778 A1

Description

[0001] The present invention relates to automotive headlamps and, in particular, to an automotive headlamp equipped with a light-emitting apparatus having a light-emitting module and a control circuit unit for controlling the lighting of the light-emitting module.

[0002] In recent years, active developments have been going on for automotive headlamps using semiconductor light emitting elements such as LEDs (light emitting diodes). Proposed in this connection have been a light source unit where at least one of means for electrically connecting these light emitting elements to a circuit substrate is so provided as to pass through the irradiation direction as seen from the light emitting elements (see Patent Document 1, for example).

[0003] [Patent Document 1] Japanese Unexamined Patent Application Publication (Kokai) No. 2005-32661.

[0004] Also pursued actively today is the development of automotive headlamps that suppress glare to a driver of a preceding vehicle by controlling the light of each of a plurality of light-emitting modules and switching the light distribution patterns. In such automotive headlamps, control circuits for controlling the respective lightings of the plurality of light-emitting modules are required. At the same time, where complex lighting control is to be performed on the plurality of light-emitting modules, a case arises where it is difficult to perform control using a single control circuit. However, when a plurality of control circuit units, for controlling the lightings of the light-emitting modules, corresponding respectively to the plurality of light-emitting modules, there may be cases that the light path of light irradiated from the automotive headlamps is blocked depending on the arrangement of electronic components constituting the control circuit units.

[0005] Thus, the present invention has been made to solve the above-described problems, and a purpose thereof is to avoid a situation that the light path of light used for irradiation is obstructed by a control circuit unit for controlling the lighting of a light-emitting module.

[0006] In order to resolve the above-described problems, an automotive headlamp according to one embodiment of the present invention includes: a light-emitting module; a control circuit unit configured to control the lighting of the light-emitting module; a support substrate configured to support both the light-emitting module and the control circuit unit; and a reflector configured to reflect, through an inner surface of the reflector, light emitted by the light-emitting module and collect the reflected light. The support substrate is arranged in a manner such that the control circuit unit is positioned in a region outside the reflector.

[0007] By employing this embodiment, a situation where the light path of light, collected by the reflector, out of the light emitted by the light-emitting module is obstructed by the control circuit unit can be prevented. Thus, automotive headlamps that utilize the light highly efficiently can be provided.

[0008] The automotive headlamp according to this embodiment may further include an electrically conductive member that electrically connects the light-emitting module and the control circuit unit. The electrically conductive member may be connected from a portion of the electrically conductive member connected to the control circuit unit to the light-emitting module, through an installation path that leads to a point more forward in a light-concentrating direction of the reflector than the light-emitting module, in a manner such that a light path of light, collected by the reflector, out of the light emitted by the light-emitting module is avoided.

[0009] By employing this embodiment, a situation can be prevented where the light path of light, used for concentration of light by the reflector, out of the light emitted by the light-emitting module is obstructed by the electrically conductive member. Thus, automotive headlamps that utilize the light highly efficiently can be provided.

[0010] The automotive headlamp according to this embodiment may further include a housing mounted on the support substrate. The electrically conductive member may be supported by the housing in a manner such that when the housing is mounted on the support substrate, a portion thereof, which is led from at least a neighborhood of the control circuit unit to the point more forward in the light-concentrating direction of the reflector than the light-emitting module, is led to the installation path. By employing this embodiment, the electrically conductive member can be easily led and wired in such a manner as to avoid the light path of light used for concentration of light by the reflector.

[0011] The electrically conductive member may be connected to the light-emitting module by an aluminum ribbon that extends forward in the light-concentrating direction of the reflector from the light-emitting module.

[0012] Also, the support substrate may be formed of a heat-radiating material.

[0013] Also, the automotive headlamp may further include a plurality of light-emitting apparatuses each having the light-emitting module, the control circuit unit, and the support substrate. Each of the plurality of light-emitting apparatuses may be used to form a different part of a light distribution pattern to be formed.

[0014] Embodiments will now be described, by way of example only, with reference to the accompanying drawings which are meant to be exemplary, not limiting, and wherein like elements are numbered alike in several Figures, in which:

FIG. 1 shows a structure of an automotive headlamp according to an embodiment.

FIG. 2 is a cross-sectional view of FIG. 1 taken along the line P-P.

FIG. 3 illustrates a light distribution pattern formed on a virtual vertical screen by automotive headlamps according to an embodiment.

FIG. 4 is a perspective view of a light-emitting apparatus according to an embodiment.

FIG. 5A is a perspective view of a first unit.

FIG. 5B is a side view of a first unit.

FIG. 5C is a top view of a first unit.

FIG. 6 is a perspective view of a second unit.

FIG. 7 is a perspective view of a third unit.

FIG. 8 is a cross-sectional view of a light-emitting apparatus.

[0015] The preferred embodiments of the present invention (hereinafter referred to as "embodiments") will be described in detail with reference to the accompanying drawings.

[0016] FIG. 1 shows a structure of an automotive headlamp 10 according to the present embodiment. FIG. 2 is a cross-sectional view of FIG. 1 taken along the line P-P. A description is given hereunder of a structure of the automotive headlamps 10 in conjunction with both FIG. 1 and FIG. 2.

[0017] The automotive headlamp 10 includes a projection lens 12, lens supporting members 14, plates 16, supporting members 22, a light-emitting apparatus 24, a light-emitting module 26, a reflector 28, a shade 30, and a heatsink 32. The projection lens 12 is a plano-convex aspheric lens, having a convex front surface and a plane rear surface, which projects a light source image formed on the rear focal plane toward a front area of a lamp as a reverted image. Hereinafter, a description will be given with reference to projection images which are formed on the virtual vertical screen installed 25 meters, for instance, in front of a vehicle. It goes without saying that the virtual plane on which the projection images are supposed to be formed is not limited to such a vertical plane only. For example, the virtual plane may be a horizontal plane that simulates the road surface.

[0018] The supporting member 22 is formed such that a plate-like member is bent in an L-shape. One of outer surfaces of the supporting member 22 is a horizontal top face 22a, whereas the other thereof is oriented forward in a direction vertical to an optical axis X of the projection lens 12. The lens supporting member 14 is formed such that a long, thin metal plate is bent in an L-shape. The plate 16 is formed of a long, thin metal plate. Both ends of the projection lens 12 in the horizontal direction are secured to the supporting members 22 by way of a pair of lens supporting members 14 and a pair of plates 16, respectively.

[0019] Three light-emitting apparatuses 24 are provided on the top face 22a so that these light-emitting apparatuses 24 are arranged side by side along the direction vertical to the optical axis X. The three light-emitting apparatuses 24 each has the light-emitting module 26 for emitting white light. Each of the three light-emitting apparatuses 24 is arranged such that a lowermost part of a light-emitting section of each light-emitting module 26 coincides with the height of the optical axis X. A description is given hereunder of these three light-emitting apparatuses 24 that are a first light-emitting apparatus 24A, a second light-emitting apparatus 24B, a third light-emitting

apparatus 24C, from left to right, facing the projection lens 12. Note that the number of light-emitting apparatuses 24 provided in the automotive headlamp 10 is not limited to three, and note also that a single light-emitting apparatus 24 or a plurality (other than three) of light-emitting apparatuses 24 may be provided in the automotive headlamp 10.

[0020] The reflector 28 is so provided as to cover the light-emitting module 26 of each of the three light-emitting apparatuses 24 from above. The reflector 28 has a reflecting surface 28a having three curves surfaces therein so that the reflector 28 can reflect and collect the light emitted by each of the three light-emitting modules 26. As a result, the reflector 28 reflects the light emitted by each of three light-emitting modules 26 through the reflecting surface 28a and collects the reflected light.

[0021] The shade 30, which is formed in the shape of a plate, is disposed between the light-emitting section of the light-emitting module 26 and the projection lens 12. The shade 30 is arranged so that an upper edge of the shade 30 is positioned on the rear focal plane. The shade 30 blocks part of both the light emitted from the light-emitting modules 26 and the light reflected by the reflector 28, thereby forming cutoff lines of a low-beam light distribution pattern described later.

[0022] The heatsink 32 is placed below the supporting member 22. The heatsink 32 recovers the heat, generated by the light-emitting apparatuses 24, via the supporting member 22 and releases it to the outside, thereby suppressing the rise in temperature of the light-emitting apparatuses 24.

[0023] FIG. 3 illustrates a light distribution pattern formed on the virtual vertical screen by the automotive headlamps 10 according to the present embodiment. A low-beam light distribution pattern PL is formed by the automotive headlamps 10. The two automotive headlamps 10 are provided in a left front part and a right front part of a vehicle, respectively. The low-beam light distribution pattern PL is formed by this pair of automotive headlamps 10.

[0024] The low-beam distribution pattern PL, which is a left-hand low-beam distribution pattern, has a cutoff line CL1 to a cutoff line CL3 at the top end thereof. The first cutoff line CL1 to the third cutoff line CL3 are configured as follows. That is, the first cutoff line CL1 and the second cutoff line CL2 extend horizontally in such a manner that the first cutoff line CL1 is stepped down from the second cutoff line CL2 with respect to a vertical line V-V serving as the boundary line therebetween and passing through a vanishing point in a frontal direction of the lamp. The first cutoff line CL1 extends horizontally such that the first cutoff line CL1 is located on the right side of the V-V line and is located in a position lower than an H-H line. Thus, the first cutoff line CL1 is used as a cutoff line on the side of an oncoming traffic lane. The cutoff line CL3 extends obliquely from a left end of the first cutoff line CL1 toward upper left at an angle of 45 degrees. The cutoff line CL2 is formed such that it extends along the

H-H line on the left side from the intersection of the cutoff line CL3 and the H-H. Thus, the cutoff line CL2 is used as a cutoff line on the side of the driver's own lane.

[0025] The low-beam light distribution pattern PL according to the present embodiment is configured by the first light distribution pattern PL1, the second light distribution pattern PL2, and the third light distribution pattern PL3. In the low-beam light distribution pattern PL, the first light distribution pattern PL1 constitutes a right side of the V-V line. The first light distribution pattern PL1 is formed by the light emitted by the first light-emitting apparatus 24A.

[0026] In the low-beam light distribution pattern PL, the second light distribution pattern PL2 constitutes a left side of the V-V line. The second light distribution pattern PL2 is formed by the light emitted by the third light-emitting apparatus 24C.

[0027] In the low-beam light distribution pattern PL, the third light distribution pattern PL3 constitutes a middle part of PL lying across the V-V line. The third light distribution pattern PL3 is formed by the light emitted by the second light-emitting apparatus 24B.

[0028] As described above, the light distribution patterns are formed, via the single shade 30 and the projection lens 12, by the use of the light emitted by a plurality of light-emitting apparatuses 24. As a result, the positions of the cutoff lines can be accurately adjusted as compared with a case where the shades 30 and the projection lenses 12 are provided for a plurality of light-emitting apparatuses 24, respectively. Hence, the positions of the light-emitting apparatuses 24 can be adjusted with ease.

[0029] FIG. 4 is a perspective view of the light-emitting apparatus 24 according to the present embodiment. The light-emitting apparatus 24 includes a first unit 40, a second unit 42, and a third unit 44. The first unit 40 is provided with the light-emitting module 26. The light emitting apparatus 24 is constructed by first placing the second unit 42 on the first unit 40 and then the third unit 44 on top of them.

[0030] FIG. 5A is a perspective view of the first unit 40, FIG. 5B is a side view of the first unit 40, and FIG. 5C is a top view of the first unit 40. A description will be given below of a structure of the first unit 40 by referring to FIGS. 5A to 5C.

[0031] The first unit 40 includes a heat-radiating substrate 50, a light-emitting module 26, and a lower-side circuit unit 60. The heat-radiating substrate 50 is shaped in a rectangular plate made of aluminum which is a heat-dissipating material with excellent thermal conductivity. It is to be noted that heat-dissipating material, such as aluminum alloy, copper, or copper alloy, may be used in the place of aluminum. Provided on an upper surface 50a of the heat-radiating substrate 50 is a raised portion 50b for placing the light emitting module 26 thereon, which is located near one end of the heat-radiating substrate 50 in the extending direction.

[0032] The lower-side circuit unit 60 is mounted on the upper surface 50a of the heat-radiating substrate 50 near

the other end thereof in the extending direction. In other words, the heat-radiating substrate 50 supports both of the light emitting-module 26 and a control circuit unit 106 on the same side, that is, in positions above the heat-radiating substrate 50. The lower-side circuit unit 60, together with a coil to be discussed later, constitutes a lighting control unit for controlling the lighting of the light-emitting module 26. The lower-side circuit unit 60 is configured with the electronic components mounted on an alumina substrate 62, which is also a heat-dissipating material with excellent thermal conductivity, by the use of solder or some electrically-conductive adhesive. The lower-side circuit unit 60 is firmly fixed to the upper surface 50a of the heat-radiating substrate 50 using an adhesive. At this time, an adhesive which displays a thermal conductivity of 0.5 W/m.K or above and excellent heat radiation is used.

[0033] The light emitting module 26 includes a light-emitting section 52 and a sub-mount 54. The sub-mount 54 is shaped in a rectangular plate. The light-emitting section 52 is shaped in a rectangular plate. The light-emitting module 26 is placed on the raised portion 50b of the heat-radiating substrate 50 in such a manner that the light-emitting section 52 extends perpendicular to the optical axis X of the projector lens 12. The light-emitting module 26 is firmly fixed to the heat-radiating substrate 50 by adhesion. At this time, too, an adhesive which displays a thermal conductivity of 2.0 W/m.K or above and excellent heat dissipation is used.

[0034] The light-emitting section 52 has a plurality of semiconductor light emitting elements 56 (four of them in the present embodiment) that emit the white light. Each semiconductor light emitting element 56 is formed of a square (1mm×1mm) and has an LED. The light-emitting section 52 is structured such that the plurality of semiconductor light emitting elements 56 are installed side by side and vertical to the optical axis X. That is, the direction along which the semiconductors 56 are arranged side by side is vertical to the optical axis X. Note that, in the place of the LED, the semiconductor light emitting element 56 may have another element-like light source, such as a laser diode, which performs surface emitting in approximately point-like manner.

[0035] Provided on the upper surface of the sub-mount 54 is an electrode 58. The electrode 58 is so provided as to electrically connect a plurality of semiconductor light emitting elements 56 to each other in series or in parallel.

[0036] Thus the heat-radiating substrate 50 supports the light-emitting module 26 and the lower-side circuit unit 60 in such a manner as to recover the heat emanating from each of them. This setup enables recovery of heat from both the light-emitting module 26 and the lower-side circuit unit 60 in a simpler structure than the provision of heat-radiating members for them respectively and can also reduce the space that is occupied by such heat-dissipating members.

[0037] The heat-radiating substrate 50, which is formed plane-symmetrically, supports the light-emitting

module 26 in such a manner that the center of the light-emitting section 52 is located on the plane of symmetry. This allows the heat-radiating substrate 50 to be used commonly by an automotive headlamp provided on the left side of a vehicle and an automotive headlamp provided on the right side thereof.

[0038] Also, the heat-radiating substrate 50 has a pair of fixation recesses 50c near the raised portion 50b. The heat-radiating substrate 50 is secured to the support member 22 with screws that are screwed into the support member 22 passing through the inside of the fixation recesses 50c.

[0039] The pair of fixation recesses 50c is located on a straight line passing through the center of the light-emitting section 52 and perpendicular to the optical axis X. Therefore, the heat-radiating substrate 50 is fixed to the support member 22 at two positions which straddle the center of the light-emitting section 52 on the straight line passing through the center of the light-emitting section 52 of the light-emitting module 26. Provision of the fixation recesses 50c in these positions can prevent the lifting of the heat-radiating substrate 50 from the support member 22 below the light-emitting module 26. Thus the heat produced by the light emitting module 26 is conveyed smoothly to the heatsink 32 through the support member 22. It should be noted that the fixation recesses 50c may be provided on one of the other straight lines passing through the center of the light-emitting section 52.

[0040] Note that when the heat-radiating substrate 50 is fixed to the support member 22 with screws, ground wire must be led out from screw positions and connected to the support member 22. In this manner, grounding can be assured at the same time as fixing with screws. Also, the fixation of the heat-radiating substrate 50 to the support member 22 is not limited to that with screws. The heat-radiating substrate 50 may be fixed to the support member 22 using rivets, clips, pins, or the like.

[0041] FIG. 6 is a perspective view of the second unit 42. The second unit 42 includes a base housing 80, bus bars 82, a connector 86, and bus bars 88. The base housing 80 is formed of a resin. The base housing 80 is constituted by a plate section 80a and a housing section 80b.

[0042] The bus bars 82 are used to electrically connect the light-emitting module 26 to the lower-side circuit unit 60. The bus bars 82, formed in strips of electrically-conductive material such as brass or phosphor bronze, are insert-molded into the base housing 80 to be fixed in an upper surface 80c of the plate section 80a thereof. Therefore, the base housing 80 functions as a support member for the bus bars 82. Provided in a middle of the plate section 80a is an opening 80d for receiving the light-emitting module 26 therein. The two bus bars 82 are arranged so that each of the two bus bars 82 passes by the opening 80d from the housing section 80b and extends to a position closer to the projector lens 12 than the opening 80d.

[0043] Provided inside the housing section 80b is a circuit accommodating area 80e for receiving the lower-

side circuit unit 60. The circuit accommodating area 80e is formed such that the circuit accommodating area 80e penetrates the housing section 80b vertically. Provided inside the circuit accommodating area 80e are a first projecting part 80f and a second projecting part 80g. The first projecting part 80f is formed such that the first projecting part 80f projects inward within the circuit accommodating area 80e from a wall in contact with the plate section 80a. The bus bars 82 are installed such that the bus bars 82 are led from the upper surface 80c of the plate section 80a to an upper surface of the first projecting part 80f.

[0044] The second projecting part 80g is so formed as to project inward within the circuit accommodating area 80e from a wall opposite to the wall on which the first projecting part 80f is disposed. Provided on the external surface of the housing section 80b, opposite to the wall surface on which the second projecting part 80g is disposed, is the connector 86 for power supply from the outside. A bus bar (not shown) connected to a terminal of the connector 86 is led to an upper surface of the second projecting part 80g.

[0045] Also, the bus bars 88 are each formed in an elongate plate bent in an L shape using an electrically-conductive material such as brass or phosphor bronze for weldability. The bus bars 88 are disposed at the four corners of the housing section 80b, respectively. The bus bars 88 are insert-molded into the base housing 80 to be fixed therein in such a manner as to project upward from the upper surface of the housing section 80b. Two of the four bus bars 88 are led to the upper surface of the first projecting part 80f, whereas the other two thereof are led to the upper surface of the second projecting part 80g.

[0046] Also, the housing section 80b is provided with locking openings 80h in four positions. These locking openings 80h are used to lock a cover housing 100 to the base housing 80.

[0047] FIG. 7 is a perspective view of the third unit 44. The third unit 44 includes a cover housing 100, a coil 102, and bus bars 104. The cover housing 100 is box-shaped with an opening underneath. The coil 102 is used as part of the control circuit unit for controlling the lighting of the light-emitting module 26. The coil 102 is installed within the cover housing 100. Accordingly, the cover housing 100 functions as a circuit unit support member supporting a part of the control circuit unit. The bus bars 104 are each formed in a plate bent in an L shape using an electrically-conductive material such as brass or phosphor bronze for weldability. The bus bars 104 are insert-molded into the cover housing 100 such that they are located near the corners of the cover housing 100, respectively. The bus bars 104 are electrically connected to the coil 102 inside the cover housing 100.

[0048] The cover housing 100 has four catches 100a. The catches 100a are each so formed as to face outward from a position even below the opening of the cover housing 100. With these four catches 100a engaging with the four locking openings 80h provided in the base housing

80 respectively, the third unit 44 is fixed to the second unit 42.

[0049] Note that, with the third unit 44 installed on the second unit 42, the four bus bars 104 come in contact with the four bus bars 88 of the second unit 42 respectively. In this manner, the coil 102 and the lower-side circuit unit 60 can be easily connected to each other electrically. The bus bars 104 and the bus bars 88 are joined with each other by welding such as laser welding or resistance welding.

[0050] FIG. 8 is a cross-sectional view of the light emitting apparatus 24. FIG. 8 shows a cross section of the light emitting apparatus 24 such that the installation path of the bus bar 82 can be observed visually.

[0051] The base housing 80, with the bus bars 82 supported thereon, is mounted on the heat-radiating substrate 50. At this time, the light emitting module 26 is received in the opening 80d of the base housing 80. A spot of the bus bar 82 more forward in the light-concentrating direction of the reflector 28 than the light-emitting module 26 and the electrode 58 of the light-emitting module 26 are connected to each other by an aluminum ribbon 84. Note that the light-concentrating direction of the reflector 28 meant here is the direction in which the light emitted by the light-emitting section 52 and reflected by the reflecting surface 28a travels. In the present embodiment, the light-concentrating direction of the reflector 28 is to be understood as the direction of light traveling in parallel with the optical axis X out of the light reflected by the reflecting surface 28a.

[0052] Use of the aluminum ribbon 84 assures connection with larger contact area than with connection by Au wire or the like, which in turn improves the long-term reliability. Also, since the aluminum ribbon 84 has a property resistant to twisting and the like, falling of wire or such trouble in the subsequent processes can be prevented. Also, while the Au wire needs a protective member, the aluminum ribbon 84 does not require such a protective member, so that the manufacturing processes of the light-emitting apparatus 24 and the number of components required therefore can be reduced.

[0053] In this manner, the bus bar 82, the aluminum ribbon 84, and aluminum ribbon 92 connect the control circuit unit 106 to the light emitting module 26 through an installation path which leads to a spot more forward in the light-concentrating direction of the reflector 28 than the light-emitting module 26 by avoiding the light path used for the concentration of light by the reflector 28 out of the light emitted by the light-emitting module 26.

[0054] More specifically, the bus bar 82 extends below a region connecting the reflecting surface 28a of the reflector 28 to the light-emitting section 52 of the light-emitting module 26 and is led to a point more forward in the light-concentrating direction of the reflector 28 than the light-emitting module 26. The aluminum ribbon 84 connects a forward end in the light-concentrating direction of the thus disposed bus bar 82 to the electrode 58 of the light-emitting module 26. As a result, a situation that

the light path is obstructed by an electrically conductive member connecting the light-emitting module 26 to the lower-side circuit unit 60 can be prevented.

[0055] Also, the bus bar 82 is supported by the base housing 80 in such a manner that when the base housing 80 is mounted on the heat-radiating substrate 50, the bus bar 82 is led from a neighborhood of the lower-side circuit unit 60 to a point more forward in the light-concentrating direction of the reflector 28 than the light-emitting module 26 by avoiding the light path used for the concentration of light by the reflector 28. Thus, the obstruction of the light path by the bus bar 82 can be prevented with certainty by fixing the bus bar 82 to the base housing 80 in advance and mounting the base housing 80 on the heat-radiating substrate 50.

[0056] Also, when the second unit 42 is installed on the first unit 40, the lower-side circuit unit 60 is received inside the circuit accommodating area 80e of the base housing 80. The lower-side circuit unit 60 is connected to the bus bars 82, which are used to connect to the light-emitting module 26, by means of the respective aluminum ribbons 92. Also, provided on an upper surface of the second projecting part 80g are bus bars 90 for connection with the connector 86. The lower-side circuit unit 60 is connected to the bus bars 90 by means of aluminum ribbons 94. Also, the lower-side circuit unit 60 is connected to each of the four bus bars 88 via an aluminum ribbon (not shown). It is to be noted that these connections can be made using electrically conductive wire such as Au wire in the place of the aluminum ribbons.

[0057] The cover housing 100 supports the coil 102 in such a manner that when the cover housing is mounted on the second unit 42, the coil 102 received in the circuit accommodating area 100b is placed right above the lower-side circuit unit 60. In this manner, division of the control circuit unit for controlling the lighting of the light-emitting module 26 into a plurality of circuit units and placement of one above the other can reduce the area to be occupied by the control circuit unit.

[0058] The control circuit unit 106 for controlling the lighting of the light-emitting module 26 is comprised of the coil 102 and the lower-side circuit unit 60. The light-emitting apparatus 24 is placed on the support member 22 such that the control circuit unit 106 is positioned in a region outside the area having the light-emitting module 26 and the reflector 28 therewithin. As a result, the control circuit unit 106 for controlling the lighting of the light-emitting module 26 can be structured integrally with the light-emitting module 26, and a situation that the light path is obstructed by the control circuit unit 106 can be prevented. Thus, it is not only possible to control the lighting of the light-emitting module 26 smoothly but also to avoid a larger size for the light-emitting apparatus 24 resulting from the provision of the control circuit unit 106 for each of the light-emitting modules 26.

[0059] The present invention is not limited to the above-described embodiments only, and those resulting from any combination of the embodiments are also ef-

fective as embodiments. Also, it is understood by those skilled in the art that various modifications such as changes in design may be added to the embodiments based on their knowledge and embodiments added with such modifications are also within the scope of the present invention.

[0060] In a modification, the automotive headlamp 10 forms a high-beam light distribution pattern instead of a low-beam light distribution pattern. At this time, each of the plurality of light-emitting apparatuses 24 is used to form a different part of the high-beam light distribution pattern. A vehicle is provided with a lighting control unit for controlling the lighting of each of the light-emitting apparatuses 24. The lighting control unit includes a CPU for executing various calculations, a ROM for storing various control programs, and a RAM to be used as work area for storing data and executing programs.

[0061] The lighting control unit acquires image data picked up, for instance, by a CCD (charge-coupled device) camera, determines whether or not there are any vehicles in front by analyzing the data, and identifies the positions of them if there are any vehicles in front. Then the lighting control unit gives a control signal to the light-emitting apparatuses 24 to turn off the light-emitting apparatuses 24 which are forming a divided light distribution pattern including the positions of the vehicles present in front. When such a control signal is inputted, the light-emitting apparatuses 24 turn off the lighting by stopping the supply of electric power to the light-emitting modules 26. At this time, provision of the control circuit unit 106 for each of the light-emitting modules 26 of the light-emitting apparatuses 24 proves effective in controlling the lighting of the light-emitting modules 26 smoothly.

Claims

1. An automotive headlamp (10) comprising:

a light-emitting module (26);
 a control circuit unit (106) configured to control the lighting of the light-emitting module (26);
 a support substrate configured to support both the light-emitting module (26) and the control circuit unit (106); and
 a reflector (28) configured to reflect, through an inner surface of the reflector (28), light emitted by the light-emitting module (26) and collect the reflected light,

wherein the support substrate is arranged in a manner such that the control circuit unit (106) is positioned in a region outside the reflector (28).

2. An automotive headlamp (10) according to claim 1, further comprising an electrically conductive member that electrically connects the light-emitting module (26) and the control circuit unit (106), wherein the electrically conductive member is con-

nected from a portion of the electrically conductive member connected to the control circuit unit (106) to the light-emitting module (26), through an installation path that leads to a point more forward in a light-concentrating direction of the reflector (28) than the light-emitting module (26), in a manner such that a light path of light, collected by the reflector (28), out of the light emitted by the light-emitting module (26) is avoided.

3. An automotive headlamp (10) according to claim 2, further comprising a housing (80) mounted on the support substrate, wherein the electrically conductive member is supported by the housing (80) in a manner such that when the housing (80) is mounted on the support substrate, a portion thereof, which is led from at least a neighborhood of the control circuit unit (106) to the point more forward in the light-concentrating direction of the reflector (28) than the light-emitting module (26), is led to the installation path.

4. An automotive headlamp (10) according to claim 2 or claim-3, wherein the electrically conductive member is connected to the light-emitting module (26) by an aluminum ribbon (84) that extends forward in the light-concentrating direction of the reflector (28) from the light-emitting module (26).

5. An automotive headlamp (10) according to any one of claim 1 to claim 4, wherein the support substrate is formed of a heat-radiating material.

6. An automotive headlamp (10) according to any one of claim 1 to claim 5, further comprising a plurality of light-emitting apparatuses (24) each having the light-emitting module (26), the control circuit unit (106), and the support substrate, wherein each of the plurality of light-emitting apparatuses (24) is used to form a different part of a light distribution pattern to be formed.

[Figure 2]

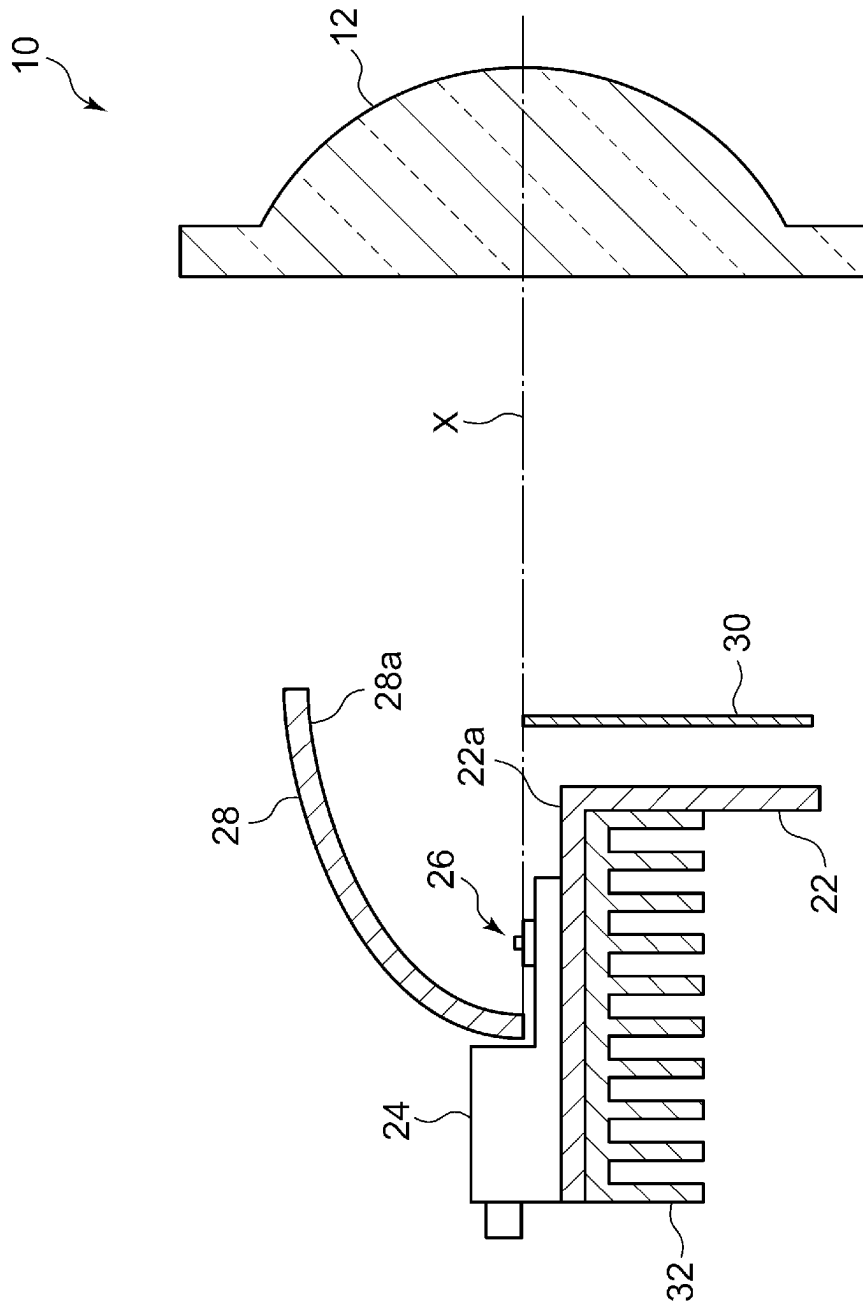

P-P

[Figure 3]

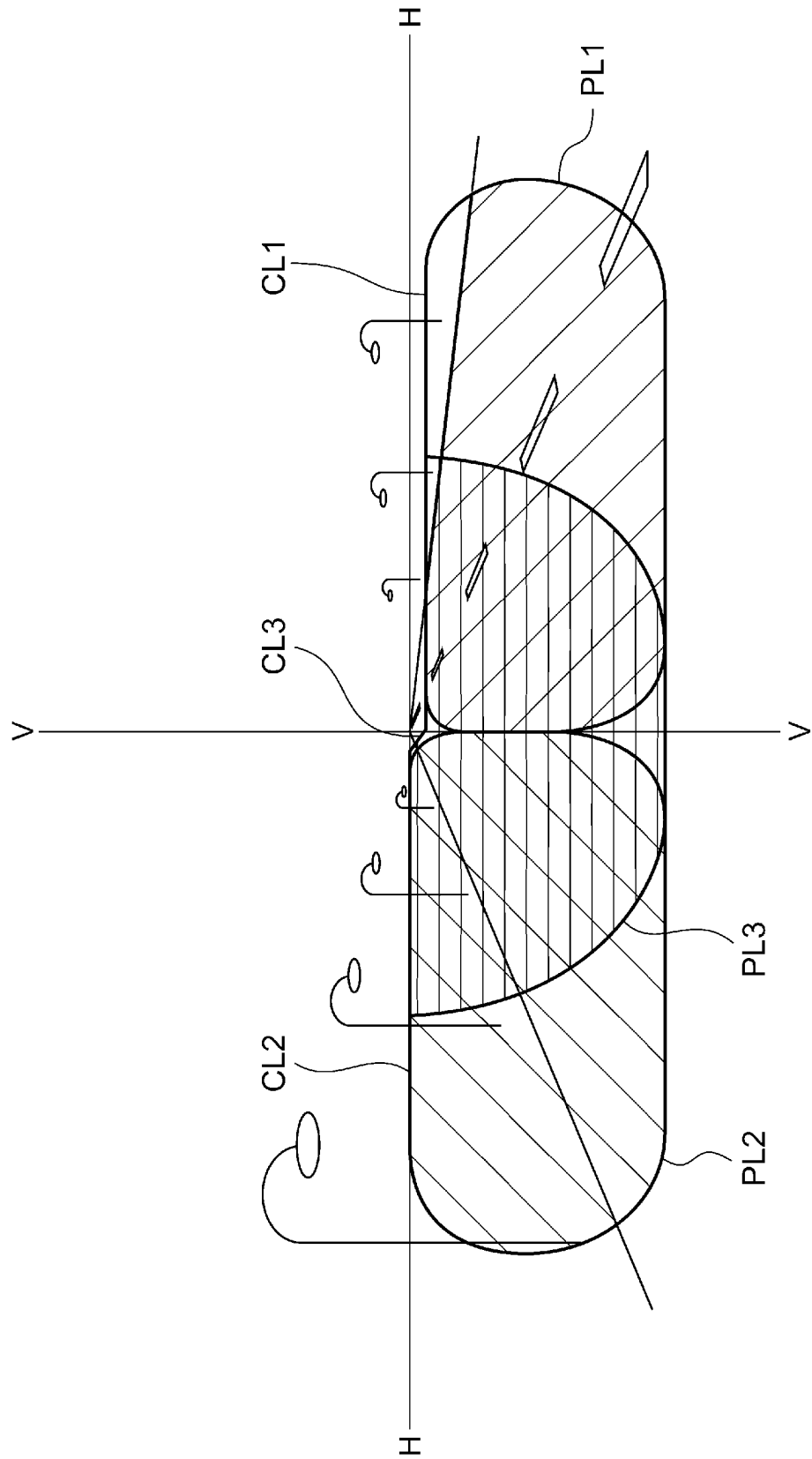

[Figure 4]

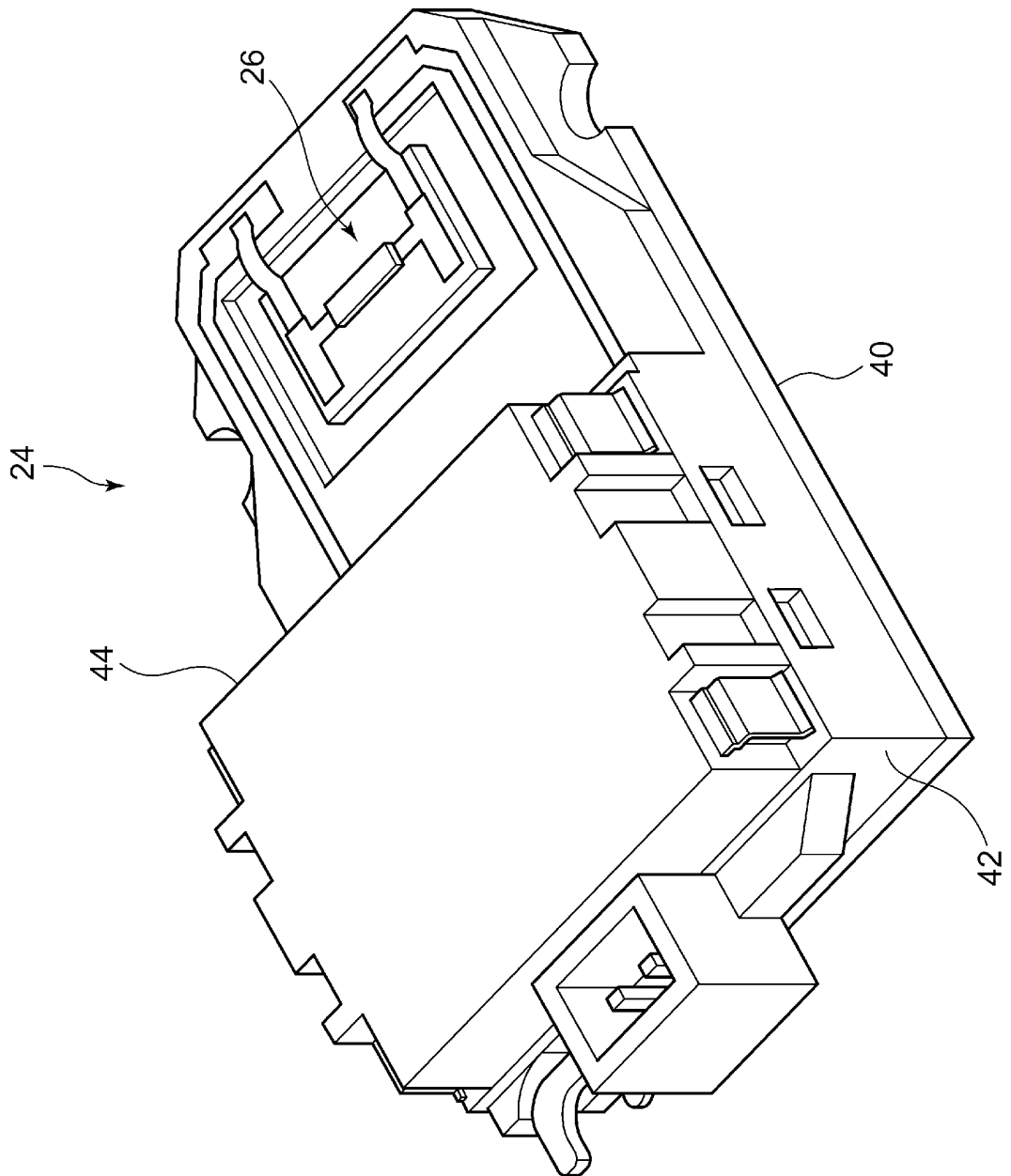

[Figure 5]

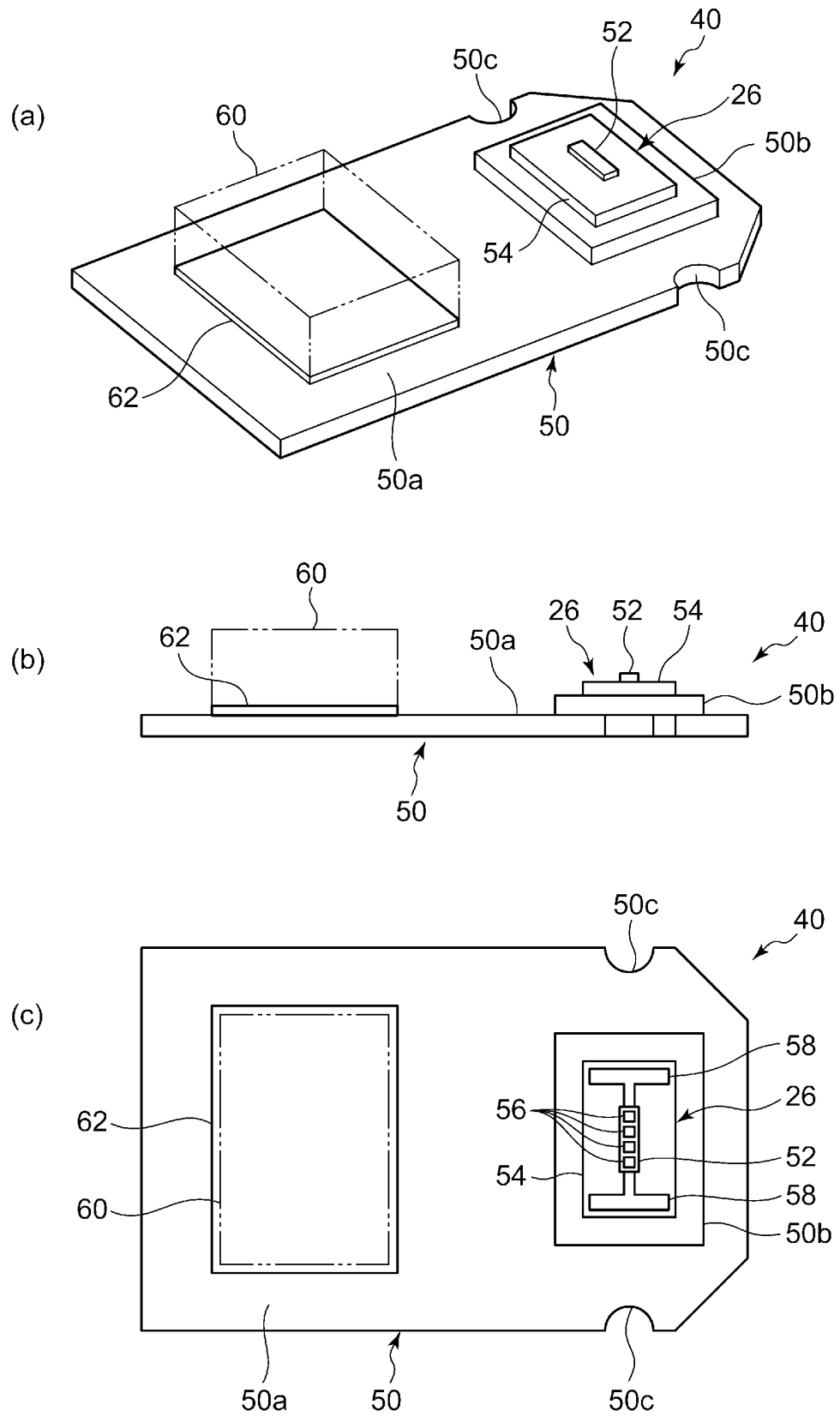

[Figure 6]

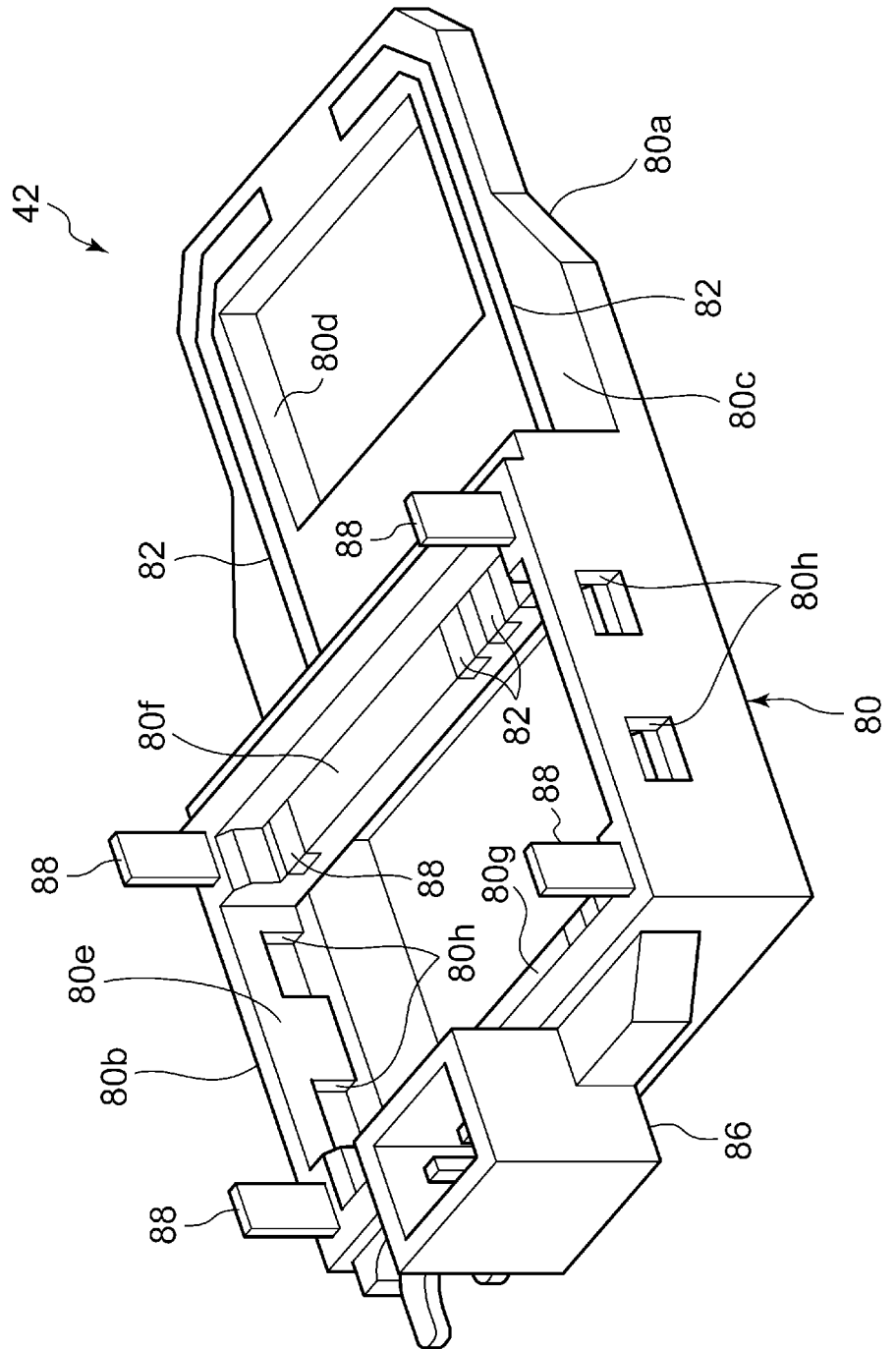

[Figure 7]

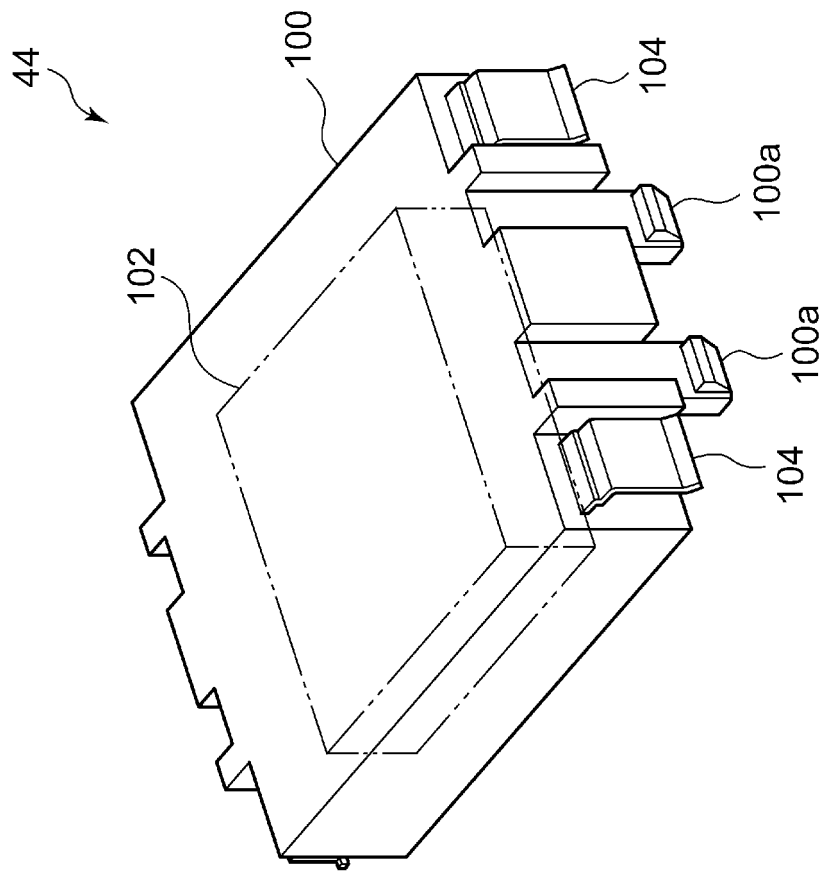

[Figure 8]

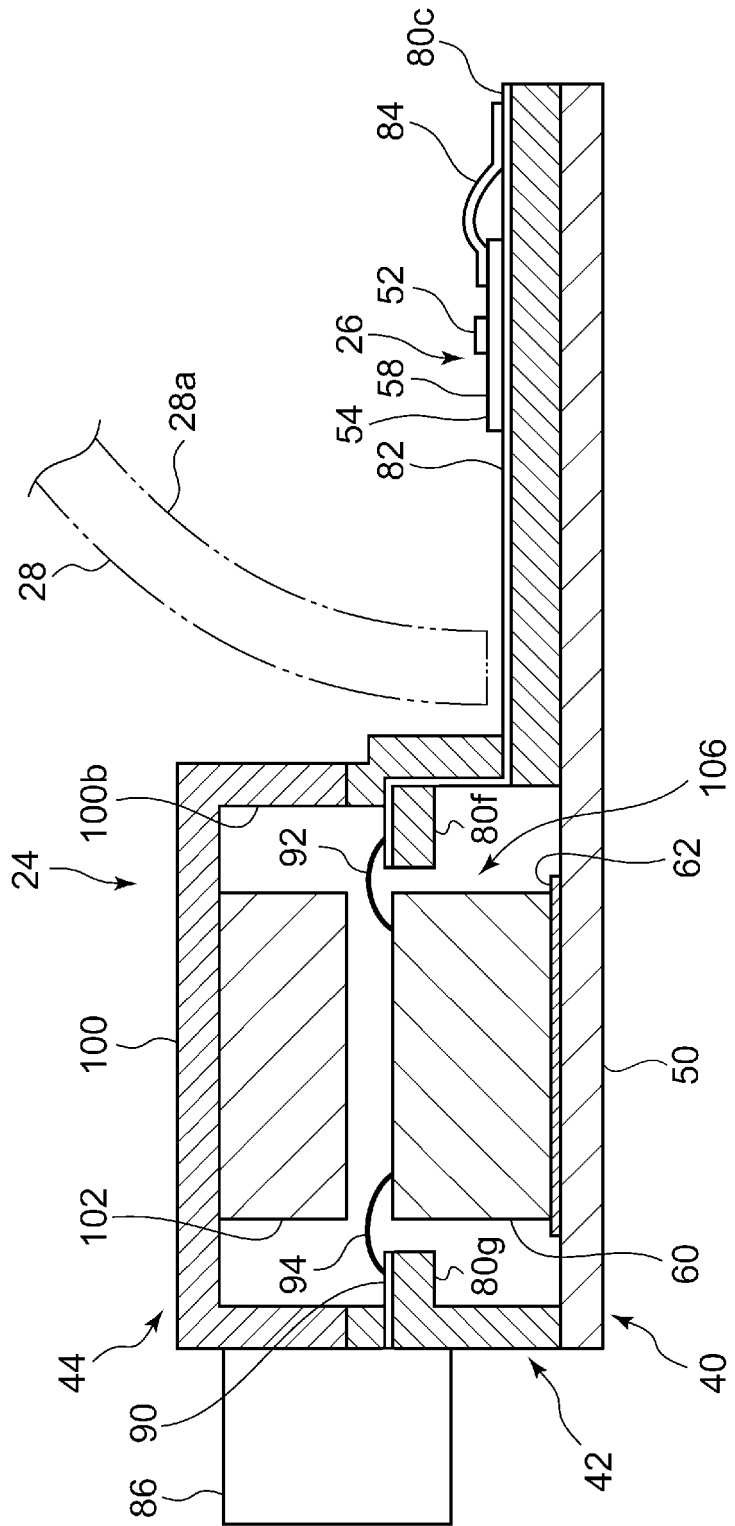

INTERNATIONAL SEARCH REPORT

International application No.

PCT/JP2010/005244

A. CLASSIFICATION OF SUBJECT MATTER <i>F21S8/10</i> (2006.01) <i>i</i> , <i>F21W101/10</i> (2006.01) <i>n</i> , <i>F21Y101/02</i> (2006.01) <i>n</i>		
According to International Patent Classification (IPC) or to both national classification and IPC		
B. FIELDS SEARCHED		
Minimum documentation searched (classification system followed by classification symbols) <i>F21S8/10</i> , <i>F21W101/10</i> , <i>F21Y101/02</i>		
Documentation searched other than minimum documentation to the extent that such documents are included in the fields searched Jitsuyo Shinan Koho 1922-1996 Jitsuyo Shinan Toroku Koho 1996-2010 Kokai Jitsuyo Shinan Koho 1971-2010 Toroku Jitsuyo Shinan Koho 1994-2010		
Electronic data base consulted during the international search (name of data base and, where practicable, search terms used)		
C. DOCUMENTS CONSIDERED TO BE RELEVANT		
Category*	Citation of document, with indication, where appropriate, of the relevant passages	Relevant to claim No.
Y A	JP 2008-262937 A (Koito Manufacturing Co., Ltd.), 30 October 2008 (30.10.2008), paragraphs [0016] to [0030]; fig. 4 to 7 (Family: none)	1, 5, 6 2-4
Y A	JP 2007-22479 A (Mitsuba Corp.), 01 February 2007 (01.02.2007), paragraph [0009]; fig. 1, 3 (Family: none)	1, 5, 6 2-4
Y	JP 2009-70679 A (Koito Manufacturing Co., Ltd.), 02 April 2009 (02.04.2009), paragraphs [0043] to [0054]; fig. 2 to 4 & US 2009/0073712 A1 & EP 2037167 A2	6
<input type="checkbox"/> Further documents are listed in the continuation of Box C. <input type="checkbox"/> See patent family annex.		
* Special categories of cited documents: "A" document defining the general state of the art which is not considered to be of particular relevance "E" earlier application or patent but published on or after the international filing date "L" document which may throw doubts on priority claim(s) or which is cited to establish the publication date of another citation or other special reason (as specified) "O" document referring to an oral disclosure, use, exhibition or other means "P" document published prior to the international filing date but later than the priority date claimed "I" later document published after the international filing date or priority date and not in conflict with the application but cited to understand the principle or theory underlying the invention "X" document of particular relevance; the claimed invention cannot be considered novel or cannot be considered to involve an inventive step when the document is taken alone "Y" document of particular relevance; the claimed invention cannot be considered to involve an inventive step when the document is combined with one or more other such documents, such combination being obvious to a person skilled in the art "&" document member of the same patent family		
Date of the actual completion of the international search 04 November, 2010 (04.11.10)		Date of mailing of the international search report 16 November, 2010 (16.11.10)
Name and mailing address of the ISA/ Japanese Patent Office		Authorized officer
Facsimile No.		Telephone No.

REFERENCES CITED IN THE DESCRIPTION

This list of references cited by the applicant is for the reader's convenience only. It does not form part of the European patent document. Even though great care has been taken in compiling the references, errors or omissions cannot be excluded and the EPO disclaims all liability in this regard.

Patent documents cited in the description

- JP 2005032661 A [0003]