

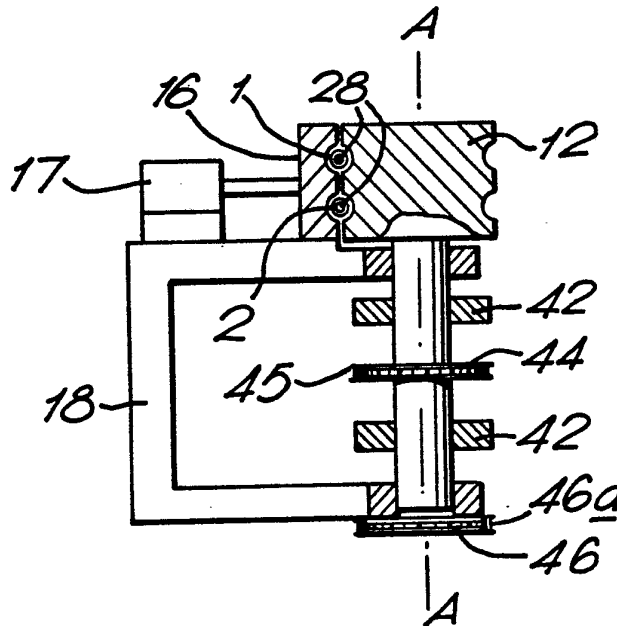

INTERNATIONAL APPLICATION PUBLISHED UNDER THE PATENT COOPERATION TREATY (PCT)

<p>(51) International Patent Classification⁴ : B21D 7/024, 9/07</p>	<p>A1</p>	<p>(11) International Publication Number: WO 87/00096 (43) International Publication Date: 15 January 1987 (15.01.87)</p>
<p>(21) International Application Number: PCT/GB86/00378 (22) International Filing Date: 27 June 1986 (27.06.86) (31) Priority Application Numbers: 8516366 8519938 8528101 (32) Priority Dates: 28 June 1985 (28.06.85) 8 August 1985 (08.08.85) 14 November 1985 (14.11.85) (33) Priority Country: GB (71) Applicant (for all designated States except US): INTEGRATED PRODUCTION MACHINES LIMITED [GB/GB]; P.O. Box 130, Brixworth, Northampton (GB). (72) Inventors; and (75) Inventors/Applicants (for US only) : LAYCOCK, Alan [GB/GB]; 40 Welland Rise, Sibbertoft, Market Harborough, Leicester (GB). GARDNER, Robert, Frederick [GB/GB]; 'Ashfield', Welford Road, Creaton, Northampton (GB).</p>	<p>(74) Agent: GIBSON, Stewart, Harry; Urquhart-Dykes & Lord, 419B Midsummer House, Midsummer Boulevard, Central Milton Keynes (GB). (81) Designated States: AT (European patent), BE (European patent), CH (European patent), DE (European patent), FR (European patent), GB, GB (European patent), IT (European patent), JP, LU (European patent), NL (European patent), SE (European patent), US. Published <i>With international search report. Before the expiration of the time limit for amending the claims and to be republished in the event of the receipt of amendments.</i></p>	

(54) Title: PIPE BENDING MACHINE



(57) Abstract

A pipe bending machine has a bending die (12), drive means for turning the bending die (12) about its axis when effecting a bending operation, an arm (18) which carries a clamp (16) for clamping the pipe (1) to the bending die, and a separate drive means acting on the clamp arm (18) and serving to turn that arm around the bending axis simultaneously with the bending die (12) being turned to effect the bending operation.

FOR THE PURPOSES OF INFORMATION ONLY

Codes used to identify States party to the PCT on the front pages of pamphlets publishing international applications under the PCT.

AT Austria	GA Gabon	MR Mauritania
AU Australia	GB United Kingdom	MW Malawi
BB Barbados	HU Hungary	NL Netherlands
BE Belgium	IT Italy	NO Norway
BG Bulgaria	JP Japan	RO Romania
BR Brazil	KP Democratic People's Republic of Korea	SD Sudan
CF Central African Republic	KR Republic of Korea	SE Sweden
CG Congo	LI Liechtenstein	SN Senegal
CH Switzerland	LK Sri Lanka	SU Soviet Union
CM Cameroon	LU Luxembourg	TD Chad
DE Germany, Federal Republic of	MC Monaco	TG Togo
DK Denmark	MG Madagascar	US United States of America
FI Finland	ML Mali	
FR France		

PIPE BENDING MACHINE

FIELD OF THE INVENTION

This invention relates to a pipe or tube bending machine of the draw bending type.

BACKGROUND AND SUMMARY OF THE INVENTION

5 A draw bending machine comprises a bending die and a clamp for clamping the pipe to the bending die. The bending die is turned under power about its axis, and this movement of the bending die is transmitted to the clamp to rotate the clamp along with the bending die,
10 and thus bend the pipe. The clamp is then released and an arm which carries the clamp is rotated under power back to its initial position. We have now devised improved arrangements for turning the bending die and the arm to which the clamp is mounted.

15 In accordance with this invention, there is provided a pipe bending machine having a bending die, drive means for turning the bending die about its axis when effecting a bending operation, an arm which carries a clamp for clamping the pipe to the bending die, and a separate drive
20 means acting on said arm and serving to turn that arm around the bending axis simultaneously with the bending die being turned to effect the bending operation.

 Thus when a bending operation is being carried out, drive is applied both to the bending die and the clamp
25 arm (instead of to the bending die only, as hitherto). Thus greater force is available for application to the pipe during the bending operation. A separate drive means has hitherto been provided for the clamp arm, but has served only to return the clamp arm to its initial position.

- 2 -

In accordance with this invention, the separate drive means is used additionally for turning the clamp arm during the bending operation.

5 For example, a first hydraulic actuator may provide drive to the bending die and a second hydraulic actuator may provide drive to the clamp arm. In a preferred embodiment of this invention, an a.c. electric motor with servo-control may provide the main drive and be coupled to drive either the bending die or the clamp arm. The
10 drive to the other element (clamp arm or bending die, respectively) may be provided by either an a.c. or d.c. motor with servo-control, or by a hydraulic drive means. Thus preferably the drive to one element (bending die or
15 clamp arm) is able to provide greater torque to that element than the other drive is able to provide to the other element when carrying out a bending operation. The main drive means may then be controlled to provide a braking effect towards the end of each bending movement, and in the limit to overcome the drive to the other element and
20 stop both the bending die and clamp arm at precisely the required position. This arrangement is particularly applicable if an electric servo-motor is used for the main drive and, for the other drive hydraulic means is used, or an electric motor (whether a.c. or d.c.) is used in a constant-
25 torque mode (its servo-control mode being used for returning the e.g. clamp arm to its starting position). If the assisting drive is provided by e.g. hydraulic means, this may be controlled to provide a reduced value of torque and/or speed to its driven element over a final portion
30 of its movement both when bending and returning to its home position: for example the flow rate of hydraulic fluid to the hydraulic actuator may be reduced for these final portions of movement.

BRIEF DESCRIPTION OF THE DRAWINGS

35 Preferred embodiments of this invention will now be described by way of examples only and with reference

- 3 -

to the accompanying drawings, in which:

FIGURE 1 is a diagrammatic plan view of an example of pipe bending machine;

FIGURE 2 is a section on the line II-II of Figure 1;

5 FIGURE 3 is a schematic diagram of one form of drive system for the machine; and

FIGURE 4 is a schematic diagram of another form of drive system for the machine.

DESCRIPTION OF THE PREFERRED EMBODIMENT

10 Referring to Figures 1 and 2, of the drawings, there is shown a pipe bending machine of the draw bending type. This particular machine is arranged to process two pipes simultaneously, particularly when forming "handed" pairs of pipes: however, the machine may instead be arranged
15 simply to handle one pipe at a time.

The machine comprises a horizontal machine bed 9 mounting a bending head 10 at its forward end. This comprises a bending die 12 of generally cylindrical form and mounted for rotation about its axis, which is disposed
20 vertically. The bending die 12 is formed with two annular grooves 14 spaced apart from each other and being semi-circular in section. The bending die 12 is provided with a short, flat-faced, tangential extension 12a which has two grooves forming tangential extensions of the grooves
25 14. A clamp block 16 is provided to co-operate with the extension 12a and is formed with two semi-circular grooves horizontally across its face, so that it can clamp two pipes 1, 2 against the bending die 12. The clamp block 16 is mounted to an arm 18 for sliding movement by an
30 hydraulic actuator 17 towards and away from the bending die extension 12a: the arm 18 is mounted for rotating about the axis of the bending die 12 so that it can be turned with the bending die during a bending operation.

- 4 -

In particular, and referring to Figure 2, the bending die 12 is mounted to a spindle 40 which is journalled to fixed structure 42 of the machine. A sprocket 44 is keyed to spindle 40 and a chain 45 is trained about this sprocket to transmit drive from a drive means 45a (Figure 1) for turning the bending die about its axis A-A. The clamp arm 18 is generally U-shaped as shown and its two limbs are journalled about the spindle 40: its upper limb carries the clamp block 16 and its lower limb carries a sprocket 46, a chain 46a being trained about this sprocket to transmit drive from a separate drive means 47 (Figure 1), for turning the clamp arm around the spindle 40 (and hence around the axis A-A).

The bending head 10 further comprises a pressure die 20 mounted to the machine bed and having a flat front surface formed with two semi-circular section grooves cooperating with the grooves of the bending die. The pressure die 20 is movable towards and away from the bending die by a hydraulic actuator 21, and is mounted so that it will move lengthwise of the pipes during a bending operation. A wiper die 22 may also be provided, fixed to the machine bed 9, and positioned opposite the pressure die 20 and shaped at its forward end to fit close against the bending die 12. The flat rear surface of the wiper die 22 is also provided with two semi-circular grooves cooperating with the grooves of the pressure die 20.

The bending machine further comprises two pipe or tube holders mounted one above the other on a carriage 24: one only of these holders is shown at 26. The carriage 24 is mounted for sliding movement along the length of the machine bed under the power of a motor 25 and via a drive belt 25 for example. Each pipe holder 26 comprises a cylindrical body through which, in use, the pipe extends, and is provided with a collet 26a which can be applied to grip the pipe. The two pipe holder bodies are

- 5 -

rotatable about their axes and coupled to a drive motor 27 so that they will rotate through equal angles but in opposite directions.

5 The machine also comprises two mandrels 28 carried at the ends of respective mandrel rods 30. The mandrels are positioned in the pipes to support the latter internally immediately upstream of the bend. The mandrel rods are mounted by holders 31 (one shown) to the machine bed beyond the trailing ends of the pipes being processed.

10 The machine is controlled by a computer numerical control system 50. In use, with two pipes 1, 2 over the mandrels and mandrel rods and held in their pipe holders 26, then firstly the control serves to advance the carriage 24 to position the two pipes correctly, relative to the bending head, ready for the first bend to be made. Then the pressure die 20 is advanced to press the pipes 1, 2 against the bending die, and the clamping block 16 is advanced to clamp the two pipes securely against the bending die, its slide engaging into the bend spindle to provide a

15 keyed location. Next the bending die 12 and clamp arm 18 are turned together around the axis A-A of the bending die (and through the angle required) by the separate drive means 45a, 47 applying power respectively to the bending die and the clamp arm via the sprockets 44 and 46. During this step the pressure die 20 slides forwardly in following the pipes. The clamping block 16 is then retracted to free the pipes from the bending die and the clamp arm 18 is returned to its initial position by its respective drive means transmitting power to it via its

20 sprocket 46.

25

30

The carriage 24 is next advanced an appropriate amount so as to position the pipes 1, 2 correctly for the next bend. The bending die 12 is returned to its initial position by its drive means acting via sprocket 44, and

35 the pressure die 20 is also returned to its original position. If the next bend in the pipes is to be effected

- 6 -

in a different plane from the first bend, then the pipe holders 26 are turned through the appropriate angle (but in opposite directions, as mentioned above). That next bend in the pipes 1, 2 is then carried out in the same manner as explained above, and the whole sequence of steps is repeated for all the following bends which are to be made in the pipes.

It will be appreciated, as mentioned above, that greater force is available for application to the pipes during the bending operation because power from the separate drive means 45a, 47 is transmitted back to the clamp arm 18 and the bending die 12. The machine is under full numerical control and for example the rotary positions of the bending die and clamp arm are at all times known to the system by the provision of rotary position encoders, as described below.

Figures 3 and 4 show various combinations of arrangements by way of examples. In Figure 3, an a.c. electric motor M provides drive via a gearbox G to sprocket 44 and thence to the bending die spindle 40, whilst a hydraulic actuator H provides drive to sprocket 46 and thence to clamp arm 18. Full closed-loop servo control for the motor is provided, a rotary position encoder E being coupled to the spindle and providing feedback to a motor control unit C. The arrangement is that the torque available from the electric motor M (i.e. at the output of its gearbox) somewhat exceeds 50% of the total torque required to carry out the bending operation: for example 60% may be provided to the bending die from the electric motor and 40% to the clamp arm from the hydraulic actuator. The electric motor is controlled to provide a braking effect towards the end of each bending movement, and finally to overcome the drive to the clamp arm and stop both the bending die and the clamp arm at precisely the required position and in

- 7 -

a smoothly controlled manner. The hydraulic actuator is preferably also controlled so as to provide a reduced value of torque and/or speed to the clamp arm over a final portion of its movement both when bending and when returning to its home position: for example the flow rate of hydraulic fluid to the hydraulic actuator over a line R may be reduced for these final portions of movement by a restrictor R.

In Figure 4, the a.c. servo motor M provides drive to the bending die spindle as before, but drive to the clamp arm is provided by an electric motor M₁, which may be an a.c. or d.c. motor with servo-control, a rotary position encoder E₁ being coupled to the clamp arm and providing feedback to a control unit C₁ for the motor M₁. The main drive for the bending operation is still provided by the a.c. servo-motor M, and the assisting drive is provided by the motor M₁: preferably the latter is used in a constant-torque mode during the bending operation and its servo-control mode is used for returning the clamp arm to its home position. Then for example the clamp arm can be returned at high speed for most of its return movement, then slowed into its home position over the final portion of the return movement. Also because the bend arm is under full numerical control during this return movement and therefore its precise position is known, the numerical control system of the bending apparatus can respond when the bend arm has reached a predetermined position close to its home position, to initiate movement of the carriage 24 to position the pipe ready for the next bending operation to be performed on that pipe.

Whilst in Figure 3 and 4 the main drive is shown applied to the bending die and the assisting drive to the clamp arm, instead the main drive may be applied to the clamp arm and the assisting drive to the bending die.

- 8 -

When the clamp is applied, the clamp arm and bending die form a solid unit on which both drives act: but when the clamp is released, the clamp arm can be returned to its home position quicker if it receives the main drive, rather
5 than the bending die. In this connection it is to be noted that the clamp arm has greater inertia than the bending die.

CLAIMS

1. A pipe bending machine having a bending die (12), drive means (M) for turning the bending die about its axis when effecting a bending operation, an arm (18) which carries a clamp (16) for clamping the pipe (1) to the bending die (12), and a separate drive means (e.g. H) acting on said arm and serving to turn that arm around the bending axis simultaneously with the bending die being turned to effect the bending operation.
2. A pipe bending machine as claimed in Claim 1, in which the drive means (e.g. M) acting on one of the two elements (clamp arm and bending die) is able to provide greater torque to its respective element (e.g. 12) than the other drive means (e.g. H) is able to provide to the other element (e.g. 18) when carrying out a bending operation, the main drive means being controlled to provide a braking effect towards the end of each bending movement.
3. A pipe bending machine as claimed in Claim 2, in which the main drive means (M) comprises an electric servo-motor and the assisting drive means comprises a hydraulic drive means (H).
4. A pipe bending machine as claimed in Claim 2 or 3, comprising means (R) for causing the assisting drive means (H) to provide a reduced value of torque and/or speed to its driven element over a final portion of its movement.
5. A pipe bending machine as claimed in Claim 2, in which the main drive means comprises an electric servo-motor (M) and the assisting drive means comprises a separate electric servo-motor (M₁).
6. A pipe bending machine as claimed in Claim 5, in which the separate, assisting electric servo-motor (M₁) is used in a constant-torque mode during a bending operation, and in a servo-control mode for a return movement to its home position.

- 10 -

7. A pipe bending machine as claimed in any one of Claims 3 to 6, in which the main electric servo-motor (M) is an a.c. electric servo-motor.

5 8. A pipe bending machine as claimed in any one of Claims 2 to 7, in which the main drive means drives the bending die and the assisting drive means drives the clamp arm.

9. A pipe bending machine as claimed in any one of Claims 2 to 7, in which the main drive means drives the clamp arm and the assisting drive means the clamp arm.

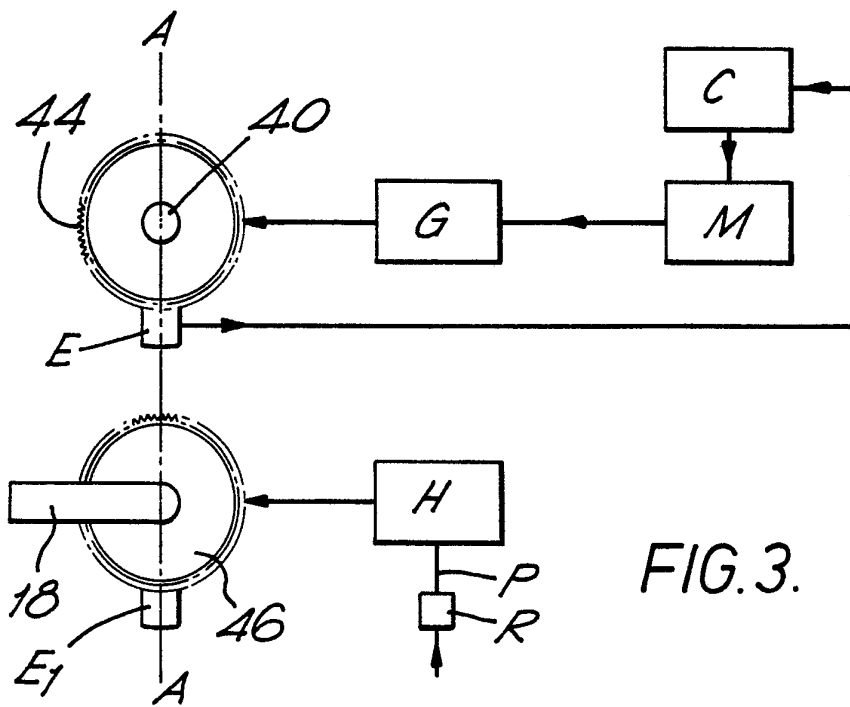

FIG. 3.

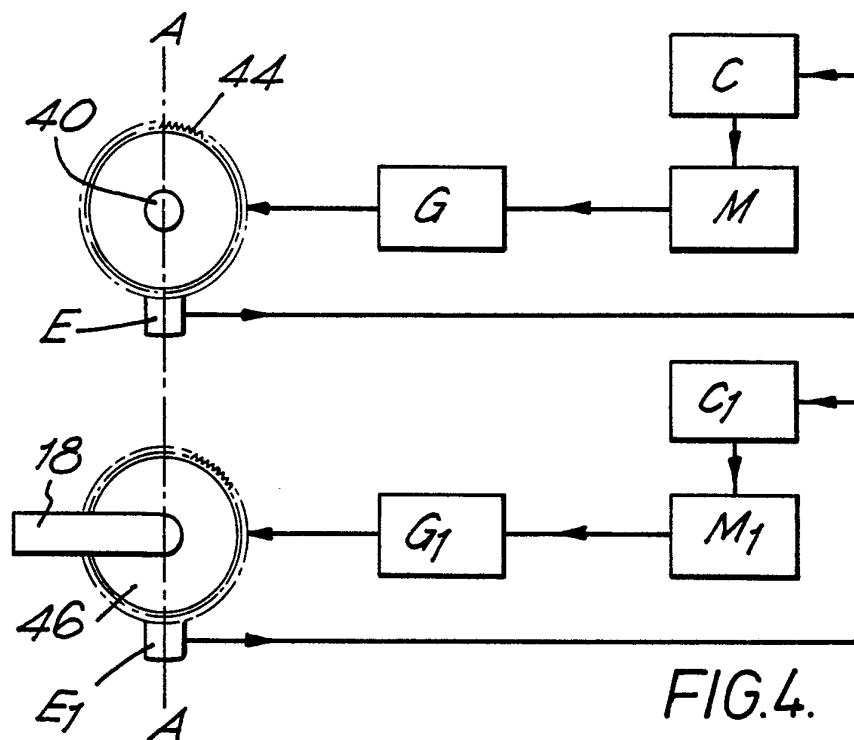
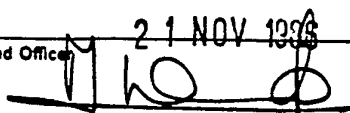

FIG. 4.

INTERNATIONAL SEARCH REPORT

International Application No PCT/GB 86/00378

I. CLASSIFICATION OF SUBJECT MATTER (if several classification symbols apply, indicate all) ⁴		
According to International Patent Classification (IPC) or to both National Classification and IPC		
IPC ⁴ : B 21 D 7/024; B 21 D 9/07		
II. FIELDS SEARCHED		
Minimum Documentation Searched ⁷		
Classification System	Classification Symbols	
IPC ⁴	B 21 D	
Documentation Searched other than Minimum Documentation to the Extent that such Documents are Included in the Fields Searched ⁸		
III. DOCUMENTS CONSIDERED TO BE RELEVANT ⁹		
Category ⁹	Citation of Document, ¹¹ with indication, where appropriate, of the relevant passages ¹²	Relevant to Claim No. ¹³
A	FR, A, 2517995 (SCHWARZE) 17 June 1983 --	1-9
A	GB, A, 2082949 (SCHWARZE) 17 March 1982 -----	1-9
<p>⁹ Special categories of cited documents: ¹⁰</p> <p>"A" document defining the general state of the art which is not considered to be of particular relevance</p> <p>"E" earlier document but published on or after the international filing date</p> <p>"L" document which may throw doubts on priority claim(s) or which is cited to establish the publication date of another citation or other special reason (as specified)</p> <p>"O" document referring to an oral disclosure, use, exhibition or other means</p> <p>"P" document published prior to the international filing date but later than the priority date claimed</p> <p>"T" later document published after the international filing date or priority date and not in conflict with the application but cited to understand the principle or theory underlying the invention</p> <p>"X" document of particular relevance; the claimed invention cannot be considered novel or cannot be considered to involve an inventive step</p> <p>"Y" document of particular relevance; the claimed invention cannot be considered to involve an inventive step when the document is combined with one or more other such documents, such combination being obvious to a person skilled in the art.</p> <p>"&" document member of the same patent family</p>		
IV. CERTIFICATION		
Date of the Actual Completion of the International Search	Date of Mailing of this International Search Report	
7th October 1986	21 NOV 1986	
International Searching Authority	Signature of Authorized Officer	
EUROPEAN PATENT OFFICE	M. VAN MOL 	

ANNEX TO THE INTERNATIONAL SEARCH REPORT ON

INTERNATIONAL APPLICATION NO. PCT/GB 86/00378 (SA. 13797)

This Annex lists the patent family members relating to the patent documents cited in the above-mentioned international search report. The members are as contained in the European Patent Office EDP file on 20/10/86

The European Patent Office is in no way liable for these particulars which are merely given for the purpose of information.

Patent document cited in search report	Publication date	Patent family member(s)	Publication date	
FR-A- 2517995	17/06/83	GB-A,B	2111416	06/07/83
		DE-A-	3149557	21/07/83
		US-A-	4537053	27/08/85
GB-A- 2082949	17/03/82	FR-A,B	2489182	05/03/82
		DE-A-	3033300	01/04/82
		US-A-	4416136	22/11/83

For more details about this annex :
see Official Journal of the European Patent Office, No. 12/82